



US00D806417S

(12) **United States Design Patent**
Katakura et al.

(10) **Patent No.:** **US D806,417 S**

(45) **Date of Patent:** **** Jan. 2, 2018**

(54) **SEATS FOR AIRCRAFT**

(71) Applicant: **JAMCO CORPORATION**,
Mitaka-shi, Tokyo (JP)

(72) Inventors: **Sachiko Katakura**, Mitaka (JP);
Sayoko Oda, Mitaka (JP); **Satoshi**
Wada, Tokyo (JP)

(73) Assignee: **JAMCO CORPORATION**, Tokyo (JP)

(**) Term: **15 Years**

(21) Appl. No.: **29/577,322**

(22) Filed: **Sep. 12, 2016**

(30) **Foreign Application Priority Data**

Mar. 14, 2016 (JP) 2016-005520

(51) **LOC (11) Cl.** **06-01**

(52) **U.S. Cl.**
USPC **D6/356**

(58) **Field of Classification Search**

USPC D6/333, 334, 344, 348, 356, 360-366,
D6/368, 369-371, 374, 377, 380, 381,
D6/708, 716; D12/52; D11/184;
D21/521, 534-539, 674, 676, 687, 688,
D21/690, 828; D23/292; D30/118
CPC ... B64D 11/06; B64D 11/064; B64D 11/0601;
B64D 11/0602; B64D 11/0606; B64D
11/0604; B64D 11/0605; B64D 11/0641;
B64D 11/0638; B64D 11/0643; B64D
11/0644; B64D 11/0647; B60N 2/01;
B60N 2/583; B60N 2/4221; B60N
2/4606; B60N 2/7011; A47C 1/036;
A47C 1/037; A47C 1/02; A47C 1/14;
A47C 1/16; A47C 1/143; A47C 1/146;
A47C 1/0342; A47C 3/12; A47C 4/03;
A47C 4/024; A47C 5/12; A47C 7/26;
A47C 7/506; A47C 7/021; A47C 7/16;
A47C 7/18; A47C 7/54; A47C 7/62;
A47C 7/70; A47C 7/744; A47C 7/185;
Y10T 29/49826

See application file for complete search history.

(56) **References Cited**

U.S. PATENT DOCUMENTS

2,608,238 A * 8/1952 Larsen A47C 7/56

D591,520 S * 5/2009 Orson D6/356

(Continued)

Primary Examiner — Kevin K Rudzinski

Assistant Examiner — Paul D Bohannon

(74) *Attorney, Agent, or Firm* — Westerman, Hattori,
Daniels & Adrian, LLP

(57) **CLAIM**

The ornamental design for seats for aircraft, as shown and described.

DESCRIPTION

FIG. 1 is a left front isometric view of seats for aircraft, showing our new design.

FIG. 2 is a front elevational view thereof.

FIG. 3 is a rear elevational view thereof.

FIG. 4 is a top plan view thereof.

FIG. 5 is a bottom plan view thereof.

FIG. 6 is a right side elevational view thereof.

FIG. 7 is a left side elevational view thereof.

FIG. 8 is a cross-sectional view thereof taken along line 8-8 of FIG. 2.

FIG. 9 is a cross-sectional view thereof, taken along line 9-9 of FIG. 2.

FIG. 10 is a cross-sectional view thereof, taken along line 10-10 of FIG. 2; and,

FIG. 11 is a cross-sectional view thereof, taken along line 11-11 of FIG. 6.

The broken line portions of the design are included to show portions of the seats for aircraft and form no part of the claimed design.

1 Claim, 4 Drawing Sheets

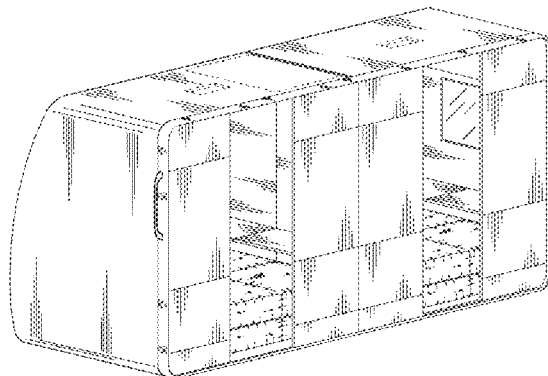

(56)

References Cited

U.S. PATENT DOCUMENTS

D617,725	S *	6/2010	Collins	D12/345
D623,577	S *	9/2010	Orson	D12/345
D623,578	S *	9/2010	Orson	D12/345
D638,551	S *	5/2011	Gann	D25/16
D661,116	S *	6/2012	Darbyshire	D6/356
D713,160	S *	9/2014	Roberts	D6/356
D715,066	S *	10/2014	Nicholas	D6/356
D718,945	S *	12/2014	Nicholas	D6/356
D724,336	S *	3/2015	Lawson	D6/356
D741,075	S *	10/2015	Lawson	D6/338
D741,609	S *	10/2015	Williams	D6/338
9,622,570	B1 *	4/2017	Holdredge	A47B 5/00
D788,683	S *	6/2017	Mariat	D12/345
2009/0302158	A1 *	12/2009	Darbyshire	B64D 11/06 244/118.6
2010/0301162	A1 *	12/2010	Hankinson	B64D 11/06 244/118.6
2012/0104165	A1 *	5/2012	Dobrusin	B64D 11/06 244/118.6
2014/0035330	A1 *	2/2014	Henshaw	B60N 3/002 297/174 R
2016/0194084	A1 *	7/2016	Rajasingham	B64D 11/0696 244/118.5
2017/0240284	A1 *	8/2017	Portoles	B64D 11/06

* cited by examiner

Fig. 1

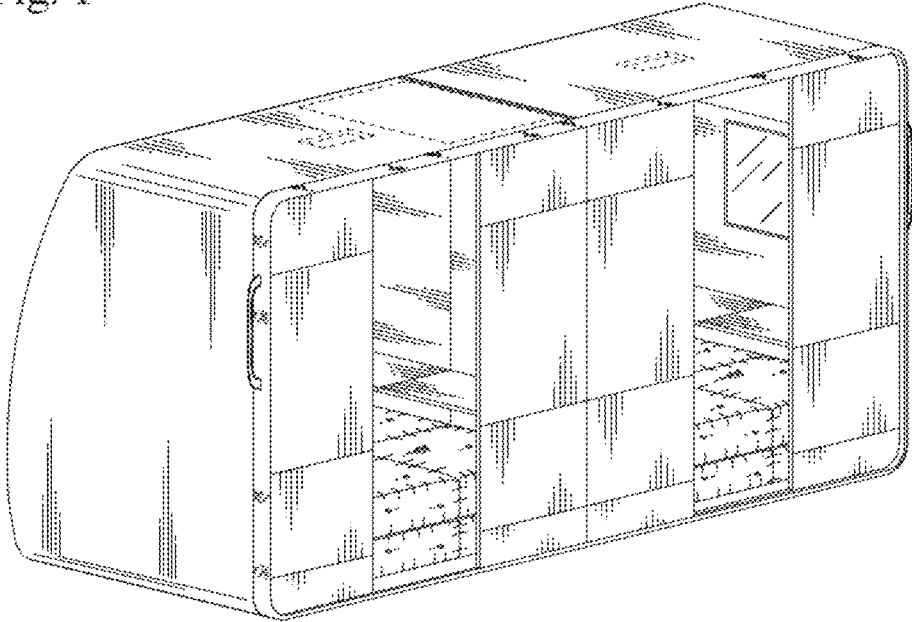

Fig. 2

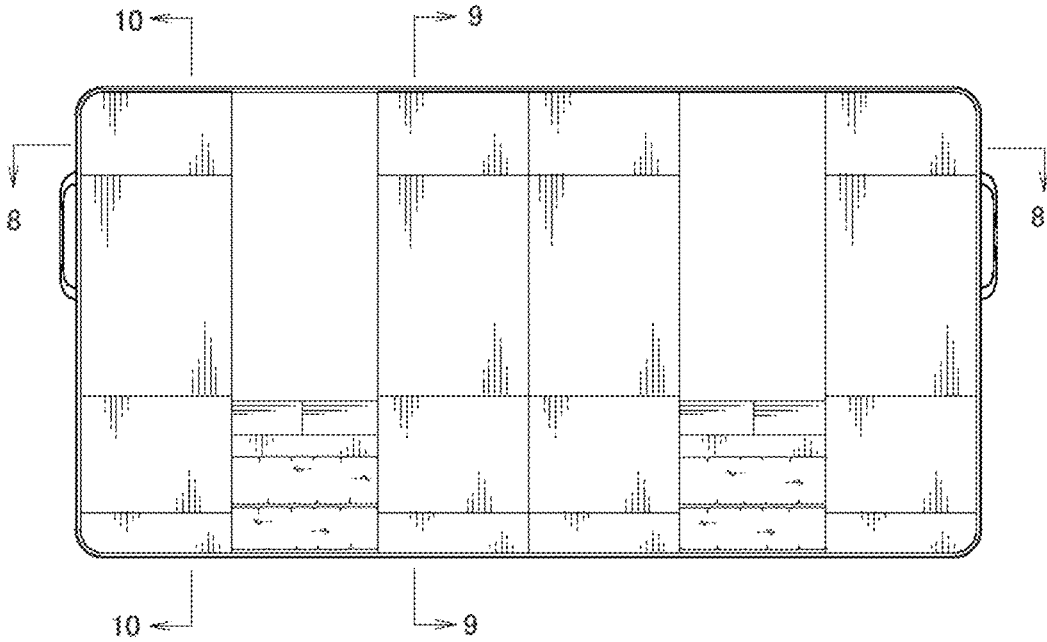

Fig. 3

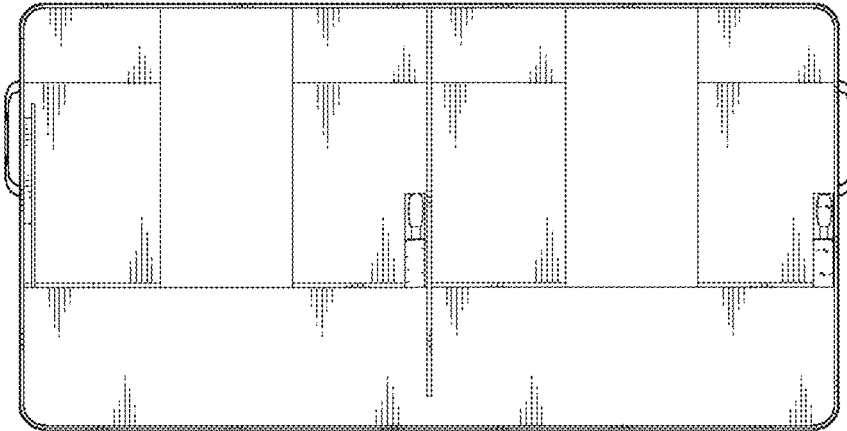

Fig. 4

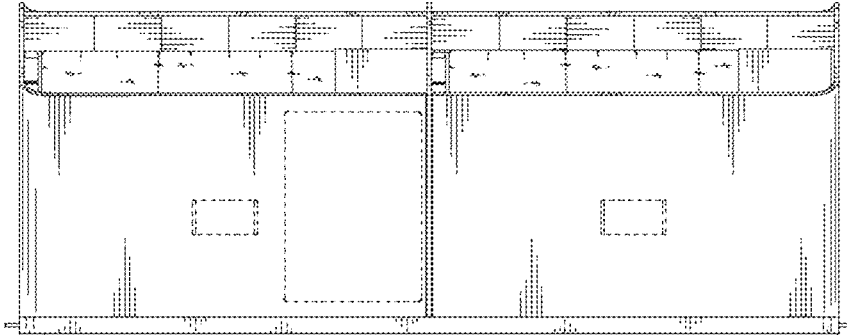

Fig. 5

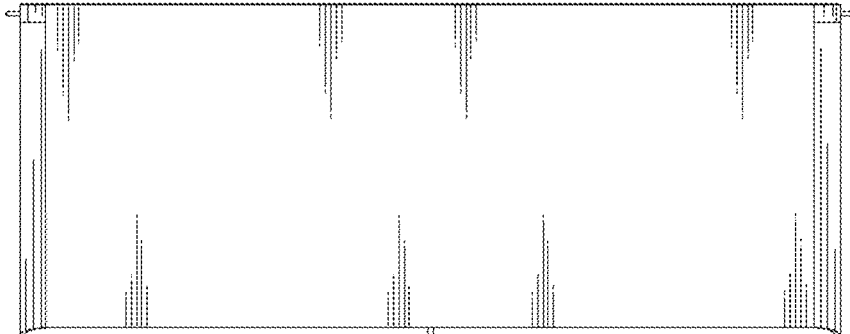

Fig. 6

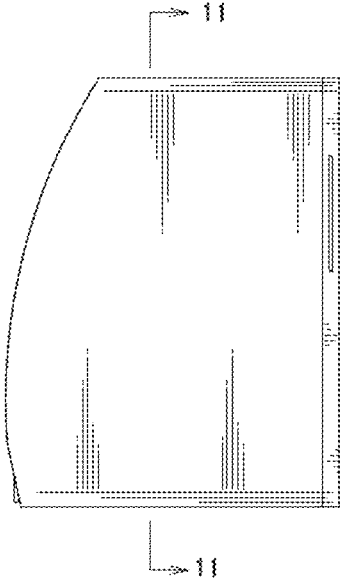

Fig. 7

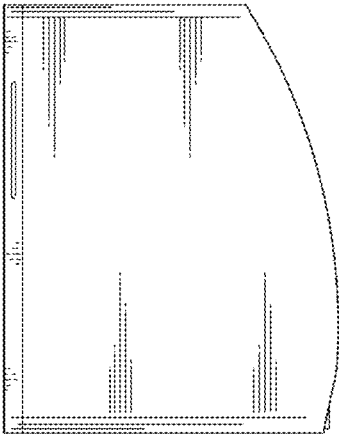

Fig. 8

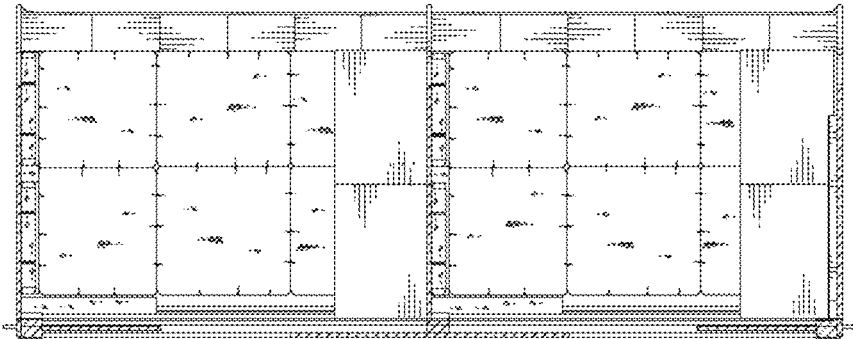

Fig. 9

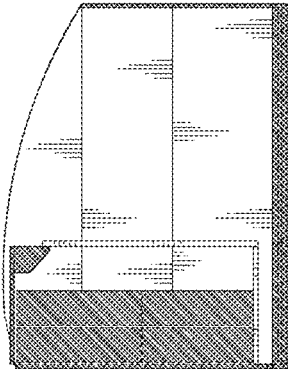

Fig. 10

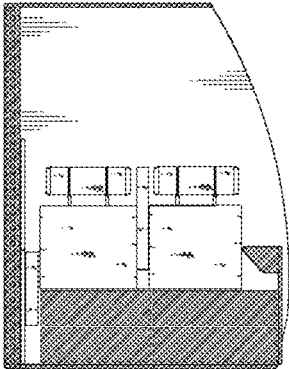

Fig. 11

