



US 20040221543A1

(19) **United States**

(12) **Patent Application Publication**

**Eleas et al.**

(10) **Pub. No.: US 2004/0221543 A1**

(43) **Pub. Date: Nov. 11, 2004**

(54) **GROUND MOUNTED POLE CONSTRUCTION**

(52) **U.S. Cl. .... 52/736.1; 52/157; 52/165; 52/169.13**

(76) **Inventors: Chrestos H. Eleas, Bluff City, TN (US); Chrestos H. Eleas II, Bluff City, TN (US)**

(57) **ABSTRACT**

Correspondence Address:  
**DONALD W. SPURRELL**  
**PATENT ATTORNEY**  
**P.O. BOX 970**  
**JOHNSON CITY, TN 37605-0970 (US)**

A structure for mounting a pole firmly in the ground, the structure having an anchor section and a pole section, wherein the anchor section is an auger, wherein the sections are hinged together with the pole section lying on the ground after the auger is screwed into the ground, and wherein the pole section can then be hoisted or lifted around hinge to an upright position, and wherein cooperating elements of connector structure are provided on the sections for firmly affixing the sections together with the anchor section remaining in the ground and with the pole in a desired upright position.

(21) **Appl. No.: 10/431,244**

(22) **Filed: May 7, 2003**

**Publication Classification**

(51) **Int. Cl.<sup>7</sup> ..... E04C 3/30; E02D 27/42**

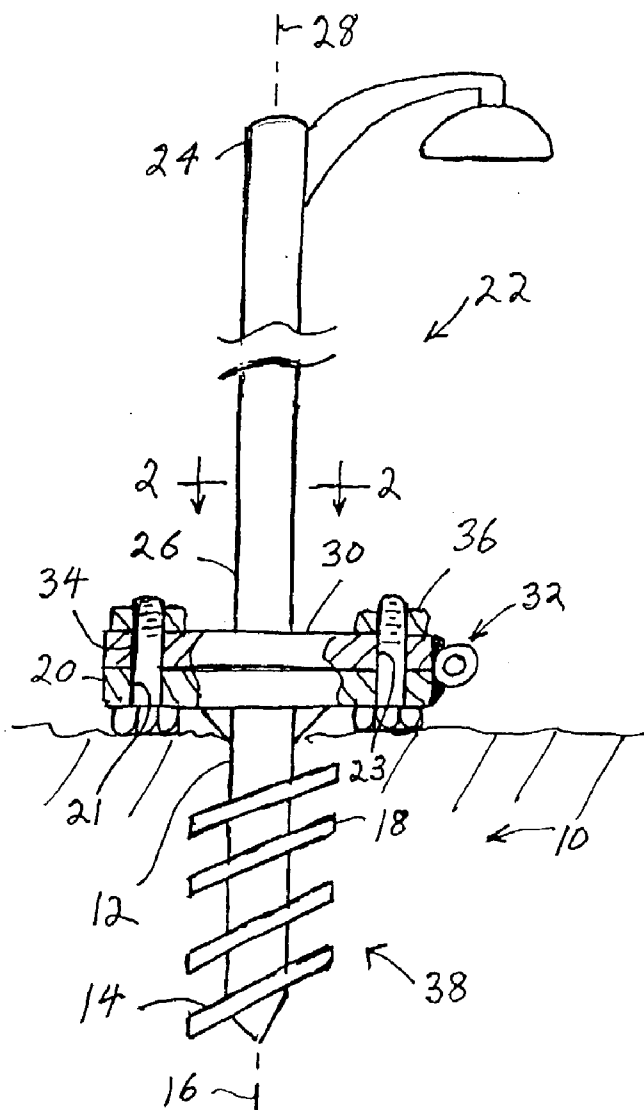

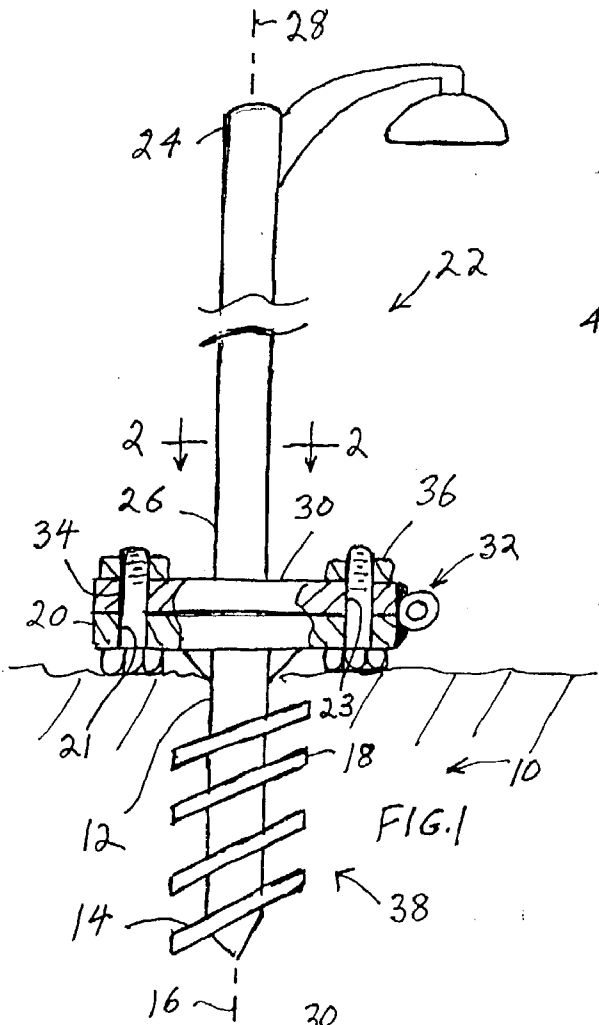

FIG. 1

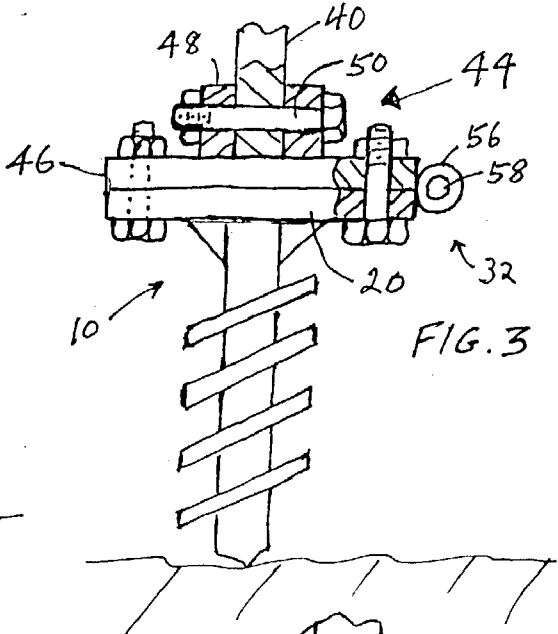

FIG. 3

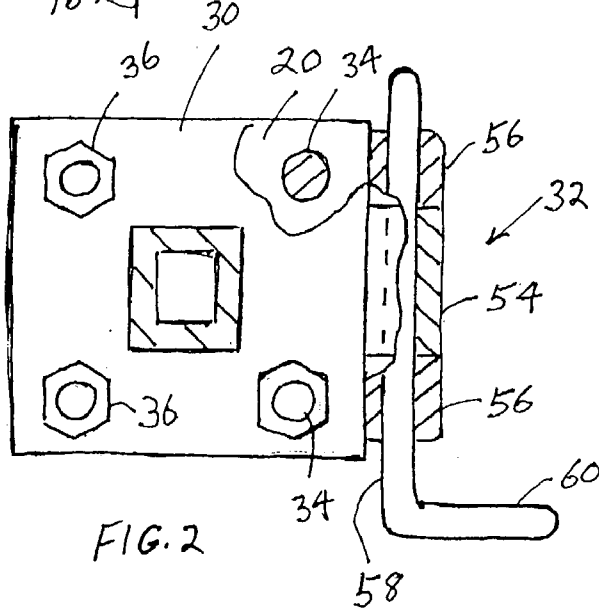

FIG. 2

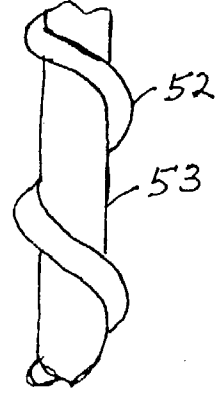

FIG. 6

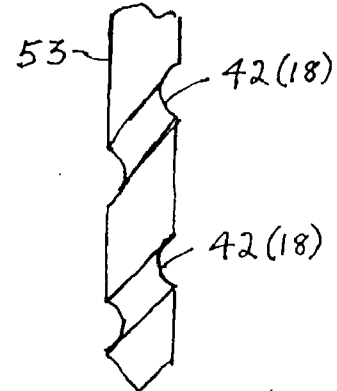
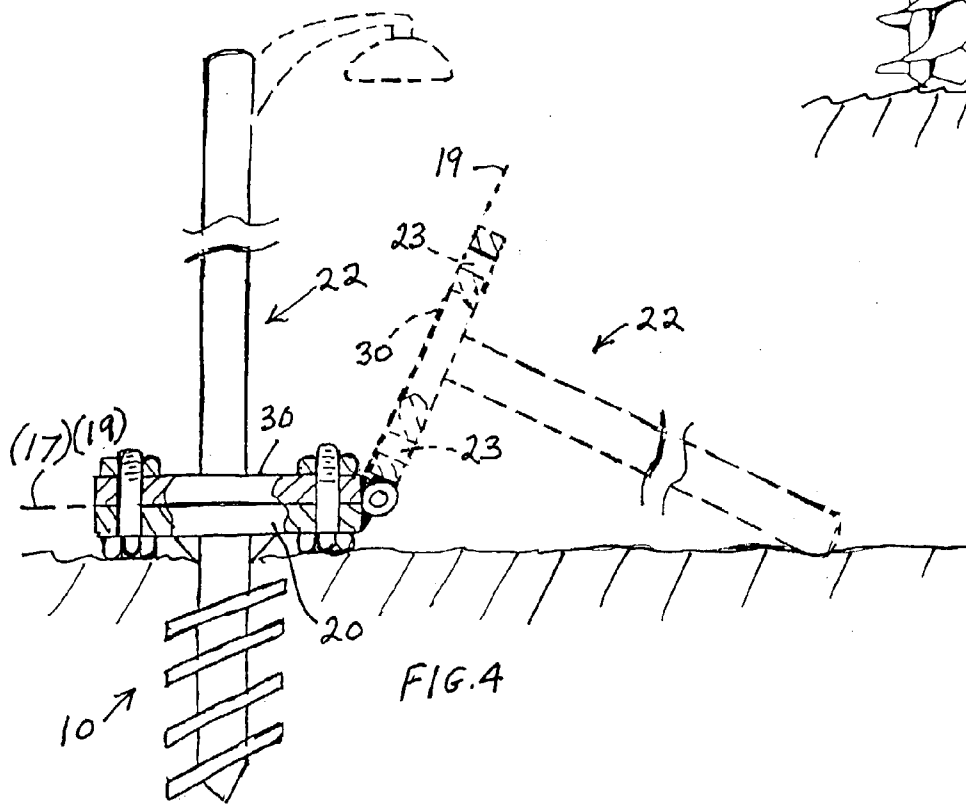
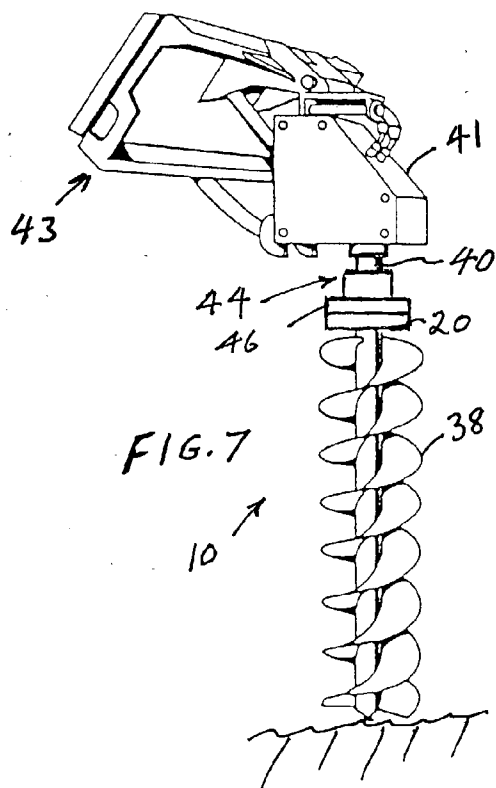

FIG. 5



## GROUND MOUNTED POLE CONSTRUCTION

### BACKGROUND OF THE INVENTION

[0001] 1. Field

[0002] This invention concerns the fixing of poles, stanchions or the like, either permanent or temporary such as light poles, sign poles, power poles, or flag poles to the ground in a manner providing great stability with minimum of time, effort and expense.

[0003] 2. Prior Art

[0004] Heretofore, the conventional method for firmly planting a post or stanchion in the ground has been to dig a hole, place the post into the hole and then pack soil, crushed stone, or concrete around the post portion within the hole. This is a time consuming excavation and refill procedure which often does not produce the desired stability in that material has to be packed into the excavated hole from which the more firm, original packed soil has been removed.

### SUMMARY OF THE INVENTION

[0005] The present invention provides a method and mechanism for anchoring a pole in the ground without having to excavate the soil, wherein an anchor section is provided and screwed into the ground, and wherein the pole is then affixed to the upper portion of the anchor section which has been left in the ground.

### BRIEF DESCRIPTION OF THE DRAWINGS

[0006] The invention will be further understood from the following description and drawings wherein the structural portions in the various figures are preferably of steel and are not drawn to scale or actual proportions and are intended to elucidate the inventive concepts involved, wherein in accordance with 35 U.S.C. 112 the best mode of practicing the present invention is clearly described, and wherein:

[0007] **FIG. 1** is a partially sectioned elevational view of the present pole section and anchor section in assembled upright mounted position;

[0008] **FIG. 2** is a cross-sectional view taken along line 2-2 in **FIG. 1** with portions broken away for clarity;

[0009] **FIG. 3** is a view of the anchor section affixed to a conventional power auger attachment of a Skid Steer machine by way of an adapter means and in position to be screwed into the ground;

[0010] **FIG. 4** is a view as in **FIG. 1** and further showing a pole and its second segment of a connector means in dotted outline in an on-the-ground initial position wherein the first and second segments are connected by a pin to form a hinge;

[0011] **FIG. 5** shows an inwardly fluted variation of the threaded portion of the anchor section;

[0012] **FIG. 6** shows an outwardly fluted variation of the thread means; and

[0013] **FIG. 7** is a perspective view of an auger attachment to a Skid Steer power drive.

### DETAILED DESCRIPTION

[0014] Referring to the drawings with particular reference to the claims hereof, the present ground mounted pole

construction generally comprises an elongated ground anchor section **10** and an elongated pole section **22**. Anchor section **10** has a proximal end portion **12**, a distal end portion **14**, and a longitudinal axis **16**. Thread means **18** of any form or pitch is provided on said distal end portion and is adapted to be forcibly screwed into the ground. A first segment **20** of a connector means is provided on said proximal end portion **12**.

[0015] Pole section **22** has an upper end portion **24**, a lower end portion **26**, and a longitudinal axis **28**. A second segment **30** of a connector means is provided on said lower end portion and is constructed substantially the same as segment **20**. These first and second segments when connected together provide a hinge means generally designated **32** whereby when the anchor section has been screwed into the ground to a desired level, e.g., at or above ground level, and with the pole section lying on the ground or other surface, the first and second segments can be connected to form the hinge means **32** and the pole section can be hoisted by hand or machine by pivoting on the hinge means to an upright position. A fastening means such as bolts **34** mounted thru bolt holes **21** and **23** and nuts **36** are engageable with the segments **30** and **20** of the pole and anchor sections for securing these sections together in a desired upright position. It is noted that shims may be used between the contact surfaces of the plates **20** and **30** to adjust the planes **17** and **19** respectively thereof and the posture or verticality of the pole, however, such is typically not required where care is taken in the operation of the power auger machine.

[0016] The anchor section **10** preferably is in the form of a conventional auger **38** which is adapted to connect to the motor output shaft **40** (**FIG. 3**) of a power auger or power drill as is readily commercially available as an attachment on a Skid Steer, front loader, or other such earth moving equipment. It is noted that the only modification of such an auger attachment which applicant employs is shown in **FIG. 3** wherein an adapter means generally designated **44** comprises an adapter plate **46** which is substantially identical to plate or first segment **20** of the anchor section and is provided with a hub **48** into which the end of said output shaft **40** is inserted and pinned by bolt **50** or the like.

[0017] The construction of hinge means **32** can be conventional wherein a bearing member **54** is welded or otherwise formed on first segment **20** and wherein bearing segments **56** are welded or otherwise formed on second segment **30**. A hinge pin or bolt **58** of any construction is removably mounted thru the bearing segments and preferably is provided with a handle means **60** to facilitate its removal from the hinge means after segments **20** and **30** are bolted together or otherwise firmly fastened together.

[0018] In accordance with the present invention, the auger member can be inwardly fluted as at **42** or outwardly fluted as at **52** in or on spindle **53** as in **FIGS. 5 and 6** and the pitch of the flutes or threads or the blades of a conventional auger can be widely varied as long as the power means **40** can be regulated to screw the anchor section into the ground rather than simply pounding it into the ground. Further in this regard, the auger attachment must be operated in a manner to screw the anchor section into the ground rather than to excavate a hole. This is accomplished by maintaining

adequate downward pressure on the anchor section during its rotation to prevent lifting of the soil upwardly by rotation of the auger.

[0019] Referring to FIG. 7, the auger adapter means 44 shown in FIG. 3 is employed and the structures numbered the same. The output or drive shaft 40 is powered typically by a hydraulic motor 41 connected to the hydraulic system of the Skid Steer and carried by an adapter structure 43 which is configured to be latched to the face plate of the Skid Steer or other work vehicle or machine.

[0020] It is noted that one of the many advantages of the present invention is that it can be employed to remove posts or the like which have been screwed into the ground, without the need for digging out packed fill dirt, concrete, crushed stone or the like. This is particularly advantageous where temporary poles such as light poles or power poles at construction sites are needed.

[0021] The invention has been described in detail with particular reference to preferred embodiments thereof, but it will be understood that variations and modifications will be effected with the spirit and scope of the invention.

I claim:

1. A ground mounted pole construction comprising an elongated ground anchor section having a proximal end portion, a distal end portion, and a longitudinal axis, thread means on said distal end portion and adapted to be forcibly screwed into the ground, a connector means first segment on said proximal end portion, an elongated pole section having an upper end portion, a lower end portion, and a longitudinal axis, a connector means second segment on said lower end portion, cooperating hinge bearing means on said first and second segments, said first and second segments when connected together providing a hinge means whereby when said anchor section has been screwed into the ground to a desired level, and with the pole section lying on the ground or other surface, said pole section can be hoisted by pivoting on said hinge means to a desired upright position, and cooperating elements of fastening means on said pole sec-

tion and said anchor section for securing said pole section to said anchor section in said upright position with said anchor section in the ground.

2. The construction of claim 1 wherein each said connector means segment comprises a steel plate welded to its said section with a contact plane of each plate oriented substantially normal to the longitudinal axis of its section, wherein a hinge bearing means is provided on an edge portion of each plate and are adapted to be pivotally mounted on a shaft to form a hinge means between said plates whereby said pole section can be pivotally hoisted or lifted from a down position to a desired upright position around said hinge means after said anchor section has been screwed into the ground.

3. The construction of claim 2 wherein said anchor section is screwed into the ground, said pole section is secured to said anchor section in an upright position, and said shaft has been removed from said hinge bearing means.

4. The construction of claim 1 wherein said distal end portion of said anchor section is a conventional hole digging auger.

5. The construction of claim 1 wherein said thread means comprises flutes formed inwardly in a spindle means.

6. The construction of claim 1 wherein said thread means comprises flutes formed outwardly on a spindle means.

7. A method for mounting a pole firmly in the ground in a desired upright position, wherein a structure is provided having an anchor section and a pole section, wherein the anchor section is an auger, and wherein the sections are adapted to be hinged together and subsequently fastened together, said method comprising screwing said auger into the ground, then with the pole lying on the ground or other substrate, hinging said sections together and hoisting or lifting the pole around the hinge to a desired upright position, and firmly affixing the sections together with the anchor section remaining in the ground and with the pole in said desired upright position.

\* \* \* \* \*