

Feb. 6, 1951

J. J. GORLINSKI

2,540,199

APPARATUS FOR CASTING METAL

Filed Dec. 1, 1948

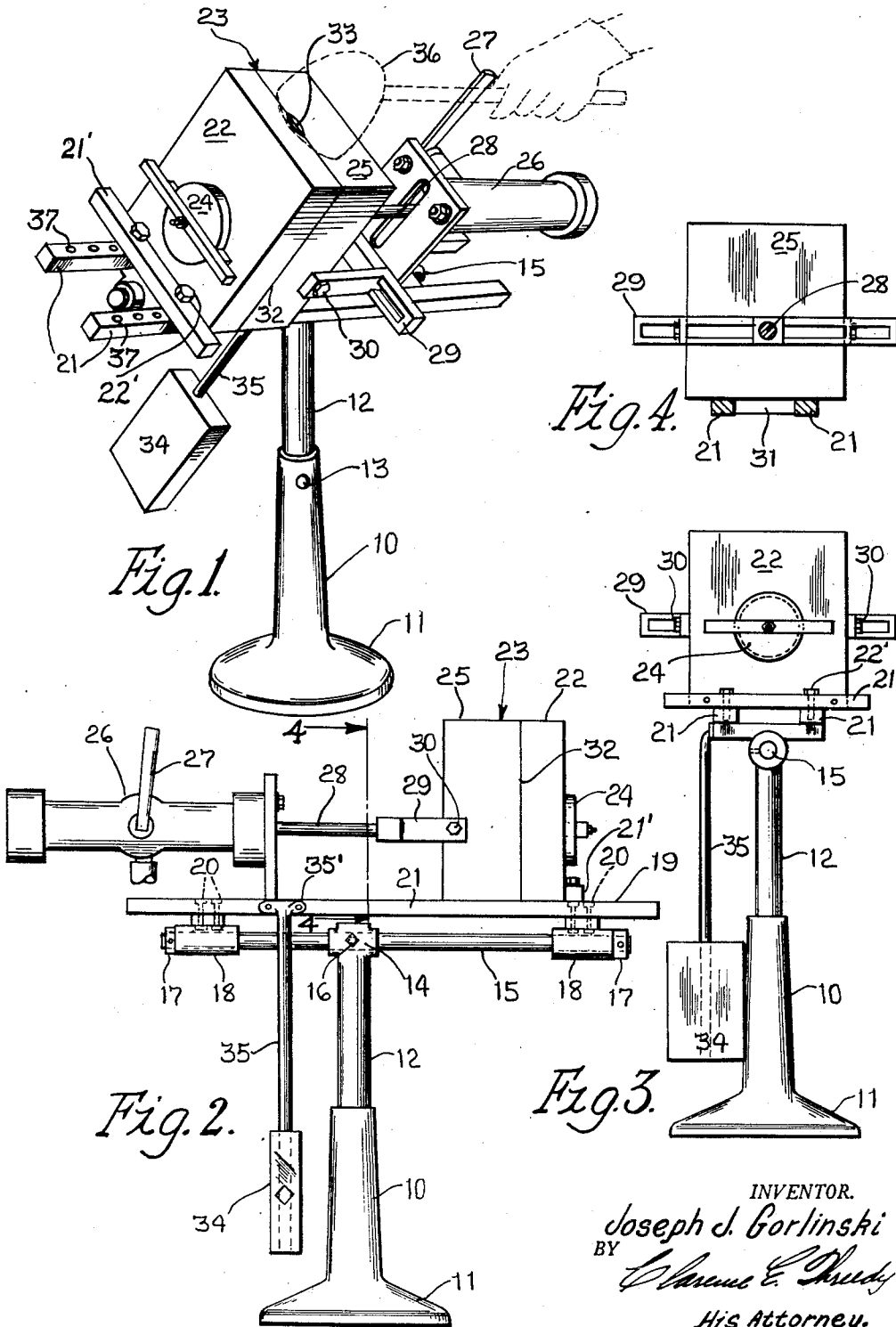

INVENTOR.
Joseph J. Gorlinski
BY
Charles E. Shady
His Attorney.

UNITED STATES PATENT OFFICE

2,540,199

APPARATUS FOR CASTING METAL

Joseph J. Gorlinski, Chicago, Ill.

Application December 1, 1948, Serial No. 62,811

1 Claim. (Cl. 22—91)

1

This invention relates to new and useful improvements in an apparatus for casting metal and has for its principal object the provision of an improved construction of this character which will be highly efficient in use and economical in manufacture.

An equally important object of the invention is the provision of a mold supporting bed plate mounted upon a supporting standard for pivotal movement about a horizontal axis whereby to facilitate the pouring of the molding metal into the mold. An arrangement of this character reduces the spilling of the metal, during the pouring operation, to a minimum and enables the operator to adjust the mold in a position which will best suit his convenience for the purpose of pouring the molding metal into the mold.

Other objects will appear hereinafter.

The invention consists in the novel combination and arrangement of parts to be hereinafter described and claimed.

The invention will be best understood by reference to the accompanying drawings showing the preferred form of construction, and in which:

Fig. 1 is a perspective view of the invention showing the mold supporting bed tilted with respect to the horizontal;

Fig. 2 is a side elevational view of the same;

Fig. 3 is an end elevational view of the invention as viewed from the right of Fig. 2; and

Fig. 4 is a sectional detail view taken substantially on line 4—4 of Fig. 3.

Referring more particularly to the drawings illustrating the preferred form of construction of my invention, a supporting pedestal is indicated at 10. This pedestal may be of any approved form or design and includes a base 11 which may be attached permanently to the floor or the like. The pedestal 10 includes a supporting standard 12 telescopically arranged in the pedestal 10 and fixed in a predetermined adjusted position by at least one set screw or bolt 13. This standard 12 may be adjusted vertically with respect to the pedestal 10.

The upper end portion of the standard 12 terminates into a bearing 14. Projected through this bearing 14 is a supporting shaft 15. This supporting shaft 15 is fixed in a predetermined position with respect to the bearing 14 by at least one set screw or bolt 16.

Secured to the shaft 15 at opposite ends thereof are retaining collars 17 which retain upon the shaft 15 for rotation axially with respect thereto bearing sleeves 18. These bearing

2

sleeves 18 are secured to a bed plate 19 as at 20. This bed plate comprises two parallelly extending spaced apart rods 21. At one end these rods fixedly support a stationary mold section 22 of the mold 23. This mold 23 is secured to the bars 21' of the bed plate 19 by a bar welded or otherwise secured to the mold section 22 and to the bars 21 by bolts 22'. This mold 23 has the usual knockout plate 24 threaded into the mold in the usual manner.

The other section 25 of the mold 23 is mounted upon the bed plate 19 for slidably movement thereon. Movement of the section 25 of the mold 23 in the present instance is accomplished by a pneumatic device 26 of any approved construction including an operating handle 27 and a shaft 28. This pneumatic device is schematically illustrated in the drawings as it in itself constitutes no part of the present invention. It may be of any approved construction in which air is utilized for moving a shaft in opposite directions.

This shaft 28 by means of a yoke 29 is connected as at 30 to the mold section 25. This mold section 25 has a depending rib 31 which works between the rods 21 to guide the mold section in its movement upon the bed plate 19.

The confronting faces 32 of the mold sections 22 and 25 at their upper portions are formed to provide an opening 33 which leads to the cavity (not shown) of the mold 23 and through which the molding metal is poured into such cavity.

To complete the invention a suitable counterbalance 34 is provided. This counterbalance 34 is carried by a rod 35 connected to and suspended from one of the adjacent rods 21, as at 35'.

In use the operator tilts the bed plate 19 to a position which will be most convenient for the pouring of the molding metal. In this position the ladle 36 containing the molding metal is positioned with respect to the opening 33 whereby to pour the molding metal through such opening into the mold cavity. During this pouring operation the operator may slowly tilt the bed plate 19 back to its original position. In so doing, there is less agitation of the molding metal with the result that a more perfect molded product is obtained. This operation also permits the gradual escape of air from within the mold sections. The tilting of this bed plate 19 and the mold 23 thereon may be accomplished by the operator by manually grasping the handle 27 or any part of the bed plate 19. The counterbalance 34 is such as to nicely balance the structure so as to reduce

3

efforts of the operator to accomplish the tilting operation to a minimum.

After the molding operation, the mold section 25 by means of the pneumatic device 26 is moved to permit removal of the molded work.

While I have shown the mold section 22 stationary upon the bed plate there may be provided in the bars 21 spaced openings 37 for the bolts 22' to accommodate mold sections of different depths.

While I have illustrated and described the preferred form of construction for carrying my invention into effect, this is capable of variation and modification without departing from the spirit of the invention. I, therefore, do not wish to be limited to the precise details of construction set forth, but desire to avail myself of such variations and modifications as come within the scope of the appended claim.

Having thus described my invention, what I claim as new and desire to protect by Letters Patent is:

A molding apparatus comprising a supporting standard providing at its upper end portion a bearing, a shaft journalled in said bearing for

4

longitudinal adjustment substantially at right angles with respect to the standard, means for connecting the shaft to said bearing in a predetermined adjusted position with respect to the standard, bearing sleeves mounted on opposite ends of the shaft for rotation about the axis of the shaft, retainer collars at opposite ends of the shaft for said sleeves, a bed plate secured to said sleeves for rotation therewith, a mold assembly including an element connected to said bed plate, and counterbalanced means carried by said bed plate.

JOSEPH J. GORLINSKI.

REFERENCES CITED

The following references are of record in the file of this patent:

UNITED STATES PATENTS

Number	Name	Date
1,855,783	Wood	Apr. 26, 1932
1,931,907	Tandy	Oct. 24, 1933
1,952,200	Flammang et al.	Mar. 27, 1934
2,015,975	Sulprizio	Oct. 1, 1935
2,266,723	Fahlman	Dec. 16, 1941