

Dec. 16, 1969

A. A. BIAGI

3,484,132

RECESSED FURNITURE HANDLE

Filed March 21, 1968

2 Sheets-Sheet 1

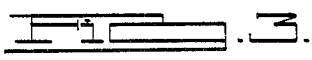
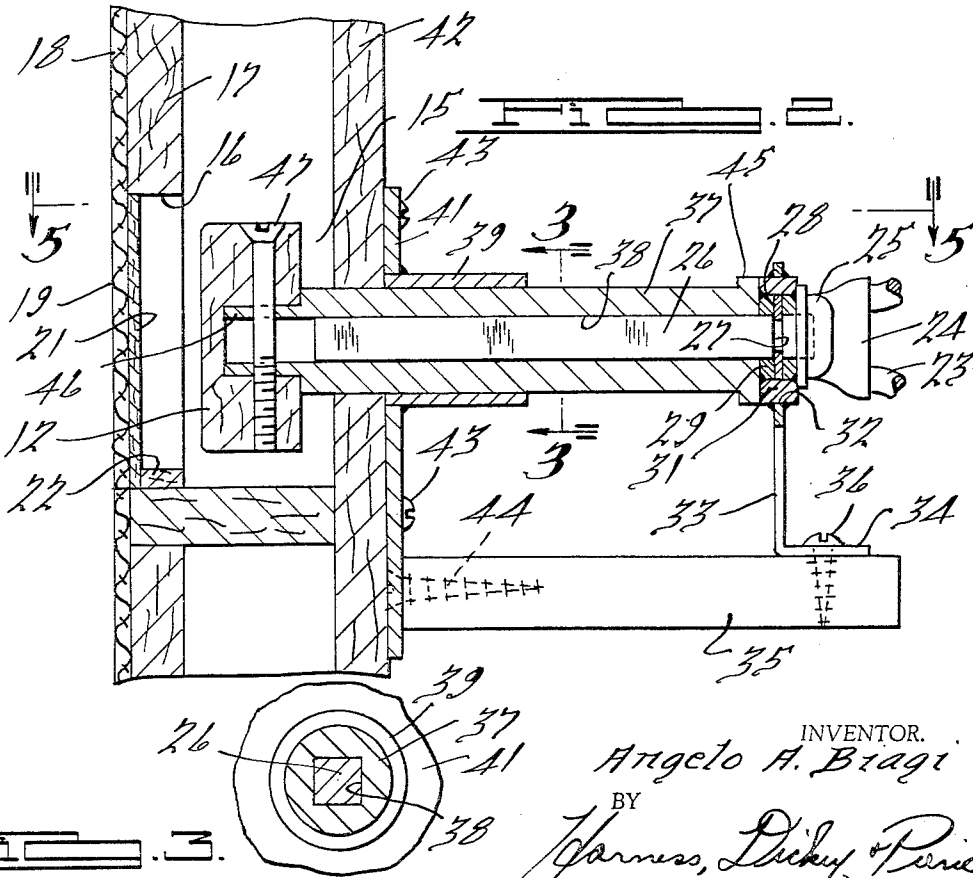
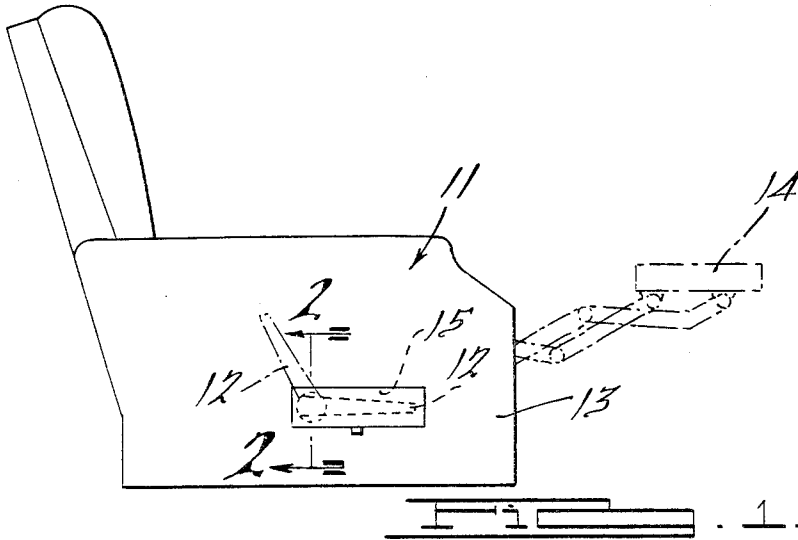

INVENTOR.
Angelo A. Biagi
BY
Harness, Dickey & Poiré
ATTORNEYS.

Dec. 16, 1969

A. A. BIAGI

3,484,132

RECESSED FURNITURE HANDLE

Filed March 21, 1968

2 Sheets-Sheet 2

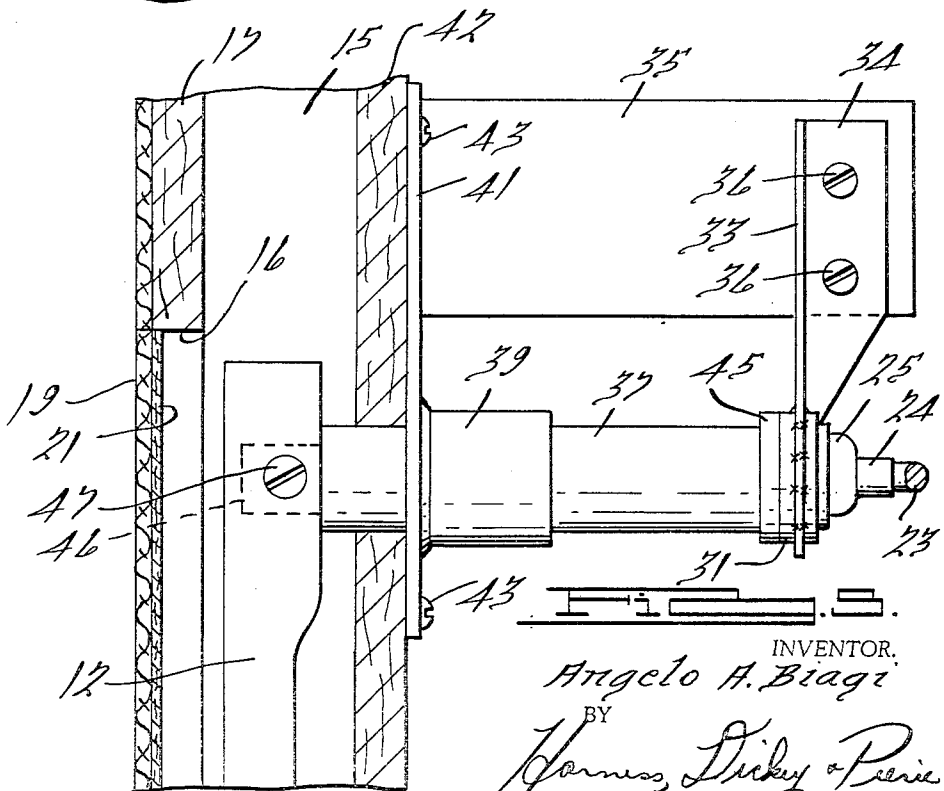
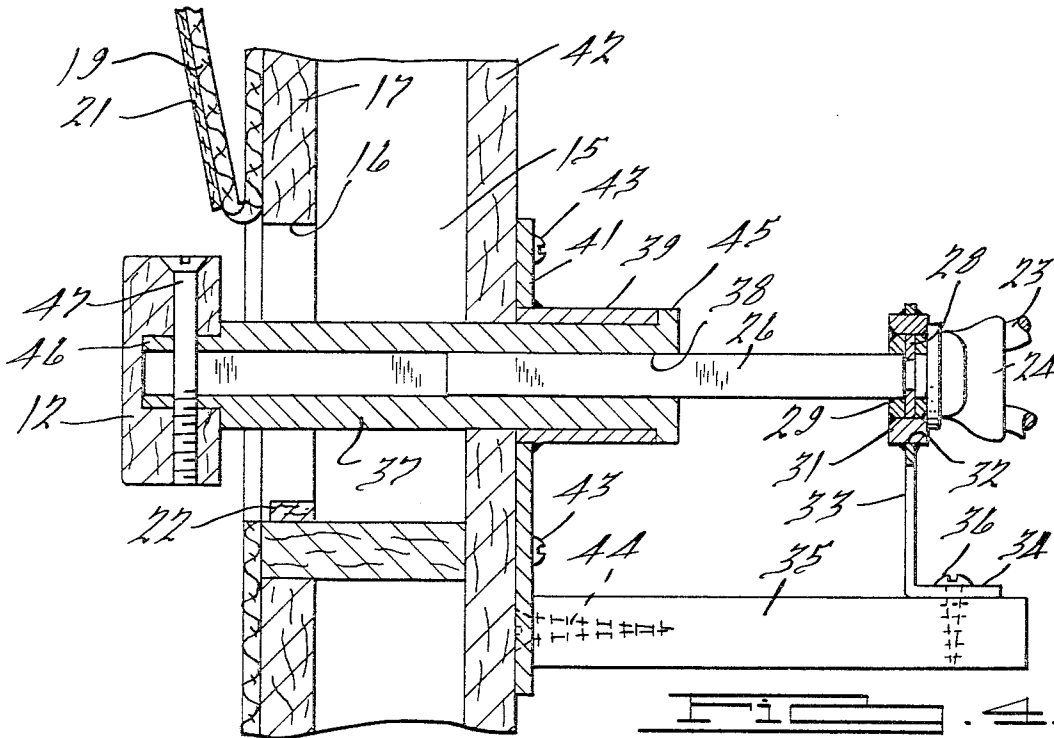

INVENTOR,

Angelo A. Biagi

BY

Horness, Dickey & Perie,
ATTORNEYS.

1

2

3,484,132

RECESSED FURNITURE HANDLE

Angelo A. Biagi, San Mateo, Calif., assignor to La-Z-Boy Chair Company, Monroe, Mich., a corporation of Michigan

Filed Mar. 21, 1968, Ser. No. 714,858

Int. Cl. A47c 7/50, 1/034

U.S. Cl. 297—69

6 Claims

ABSTRACT OF THE DISCLOSURE

A recess in the side of a chair encloses an angularly adjusted handle for operating the chair footrest to extended and retracted position. A flap of the upholstered material on the chair covers the recess and hides the handle when in retracted position.

BACKGROUND OF THE INVENTION

A chair having a handle at the side for manipulating the leg rest to extended position is shown in Patent No. 3,357,739 to E. M. Knabusch, issued Dec. 12, 1967 for "Lounge Chair." The present invention embodies a recess for enclosing the handle and hiding it from view in a manner to have it readily available when the footrest is to be manipulated thereby.

CROSS REFERENCE TO A RELATED APPLICATION

An improvement over the present invention is illustrated, described and claimed in the copending application to D. B. White et al. Ser. No. 714,857, filed Mar. 21, 1968, for "Recessed Furniture Handle," which was assigned to the assignee of the present invention.

SUMMARY OF THE INVENTION

In the above mentioned patent the handle is fixed on a shaft at the side of a chair which when turned manipulates a footrest. In the present arrangement the handle is movable into and out of a recess in the side of the chair hidden by a flap of trim material which covers the recess. A square shaft is attached to the operating mechanism and is rotatably mounted and supported against axial movement. A sleeve having a square recess extends over the square shaft for outward sliding movement thereon within a guide tube supported on the chair frame. A slot is provided in the frame through which the handle can be grasped and pulled outwardly into operable position at the side of the chair. The flap swings upwardly against the chair and permits the handle to be operated when in pulled-out position. After the footrest is retracted, the handle is in position to enter the recess when pushed thereinto by the occupant of the chair whereupon the flap will swing downwardly and close the slot to the recess.

BRIEF DESCRIPTION OF THE DRAWINGS

FIG. 1 is a side view in elevation of a lounging chair having a recess for receiving and hiding the operating handle for manipulating the footrest;

FIG. 2 is an enlarged broken sectional view of the structure illustrated in FIG. 1, taken on the line 2—2 thereof;

FIG. 3 is a sectional view of the structure illustrated in FIG. 2, taken on the line 3—3 thereof;

FIG. 4 is a view of the structure illustrated in FIG. 2, with the operating handle for the footrest shown in extended position, and

FIG. 5 is a sectional view of the structure illustrated in FIG. 2, taken on the line 5—5 thereof.

DESCRIPTION OF THE PREFERRED EMBODIMENT

The lounge chair, as illustrated in FIG. 1, is similar to that of the above mentioned patent, having a handle 12 at the side 13 for manipulating a footrest 14. The side 13 is so constructed as to have a recess 15 provided therein which communicates with a slot 16 in an outer panel 17 of the chair of a size to have the handle 12 pass therethrough. The fabric material 18 which trims the chair frame has a flap 19 cut therefrom which is reinforced by a panel 21 which abuts a stop element 22 at the bottom of the slot 16.

An element 23 of a universal joint employed in the operating mechanism is secured in an oval shaped recess in an element 24 having a head 25 thereon in which a square shaft 26 is inserted and secured in fixed relation thereto. The adjacent end of the square shaft 26 contains an annular recess 27 for receiving half washers 28 which are secured between a pair of rings 29 inserted within a ring 31 and welded together in fixed relation to each other. The ring 31 is secured within an aperture 32 in a supporting element 33 which has a flange 34 at the bottom secured to a support 35 by screws 36. With this arrangement the shaft 26 and head 25 are rotatably supported relative to the rings 29 and 31 and the shaft is retained against longitudinal movement thereby.

A sleeve 37 has a square aperture 38 disposed centrally thereof which slidably receives the square shaft 26. The sleeve 37 is slidably supported within a sleeve 39 supported on a plate 41 which is secured to the inner wall 42 of the chair frame by a plurality of screws 43. The bottom end of the plate 41 has the support 35 secured thereto by a plurality of screws 44. The outer end of the sleeve 37 has an annular flange 45 thereon which may be a part of the sleeve or a ring brazed or otherwise secured thereto. The flange 45 is aligned with the sleeve 39 and forms a stop for limiting the outward movement of the sleeve 37. The outer end of the sleeve 37 has a reduced portion 46 which extends into an aperture at one end of the handle 12 through both of which a screw 47 extends for retaining the handle fixed to the end of the sleeve 37.

In FIG. 2, the handle is illustrated in retracted position within the recess 15, the slot 16 communicating therewith is closed by the flap 19. In FIG. 4, the flap 19 is shown in raised position with the handle pulled out of the recess to be in operative position. From this position the handle can be turned to the position illustrated in FIG. 1, in which the footrest 14 will be in extended position. When the footrest 14 is retracted, the handle will be in the position parallel to the slot 16 and can then be pushed through the slot into the recess 15 and the flap 19 can then drop downwardly to close the recess, as illustrated in FIG. 2. With this arrangement the operating handle for the footrest is hidden from view when not in use but is readily available to actuate the footrest to extended or retracted position in a manner as pointed out hereinabove.

I claim:

1. In a chair having a seating portion and opposite sides, a recess in one of said sides, an angularly movable handle on a shaft for manipulating an element of the chair, said handle being movable into and out of said recess, and a horizontally hinged closure member for closing said recess when the handle is disposed therein.

2. In a chair as recited in claim 1, wherein the element manipulated by the handle is a footrest movable to an extended position and to a retracted position.

3. In a chair as recited in claim 2, wherein a square shaft is attached to said manipulating element, means

3

supporting said square shaft against longitudinal movement while permitting it to be rotated, a sleeve having a square aperture slidably mounted on said shaft, and means for securing the handle to the end of said sleeve.

4. In a chair as recited in claim 3, wherein said sleeve has a projecting flange on the end opposite to that containing the handle, and a second sleeve supported on the chair frame through which said first sleeve is longitudinally movable limited by the engagement of said flange with said second sleeve.

5. In a chair as recited in claim 4, wherein a plate is secured to said second sleeve and attached to the chair frame, and a support for the shaft supporting element secured to said plate.

6. In a chair as recited in claim 1, wherein said clos-

4

ure member is covered with the trim material of the chair.

References Cited

UNITED STATES PATENTS

3,136,578	6/1964	Tihovici	297—194
3,235,307	2/1966	Knabusch et al.	297—69 X
3,243,837	4/1966	Smith	16—110
3,357,739	12/1967	Knabusch et al.	297—69

CASMIR A. NUNBERG, Primary Examiner

U.S. Cl. X.R.

297—429