



US 20050096111A1

(19) **United States**

(12) **Patent Application Publication** (10) **Pub. No.: US 2005/0096111 A1**

Beck

(43) **Pub. Date:**

May 5, 2005

(54) **INFRARED TOY VIEWING SCOPE AND GAMES UTILIZING INFRARED RADIATION**

(52) **U.S. Cl.** 463/7

(76) **Inventor: Stephen C. Beck, Berkeley, CA (US)**

(57) **ABSTRACT**

Correspondence Address:
SELDON & SCILLIERI
18th Flr.
10940 Wilshire Boulevard
Los Angeles, CA 90024-3952 (US)

An infrared scope toy for observing a scene illuminated by infrared electromagnetic energy comprising an input focusing lens, an infrared sensor having an infrared sensitive surface and an output responsive to the infrared electromagnetic energy incident to the infrared sensitive surface, a display screen having a display surface and being operably connected to the output of the infrared sensor and capable of producing an image in the visible portion of the electromagnetic spectrum which is similar to the infrared electromagnetic energy incident to the infrared sensitive surface of the infrared sensor. The infrared scope toy overcomes the problem of seeing in low or nonexistence visible light situations and provides a toy for children and others, which may be used in playing games.

(21) **Appl. No.:** 10/982,732

(22) **Filed:** Nov. 5, 2004

(30) **Foreign Application Priority Data**

May 7, 2003 (WO)..... PCT/US03/14051

Publication Classification

(51) **Int. Cl.⁷** A63F 9/24

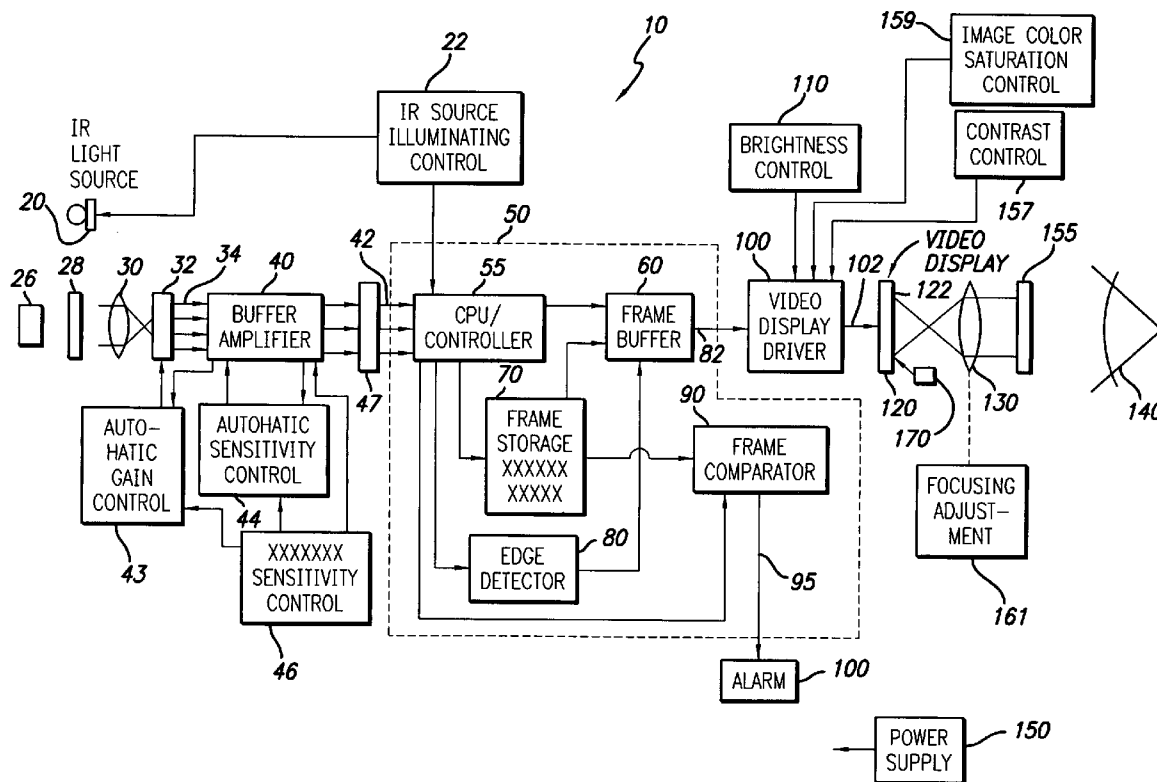

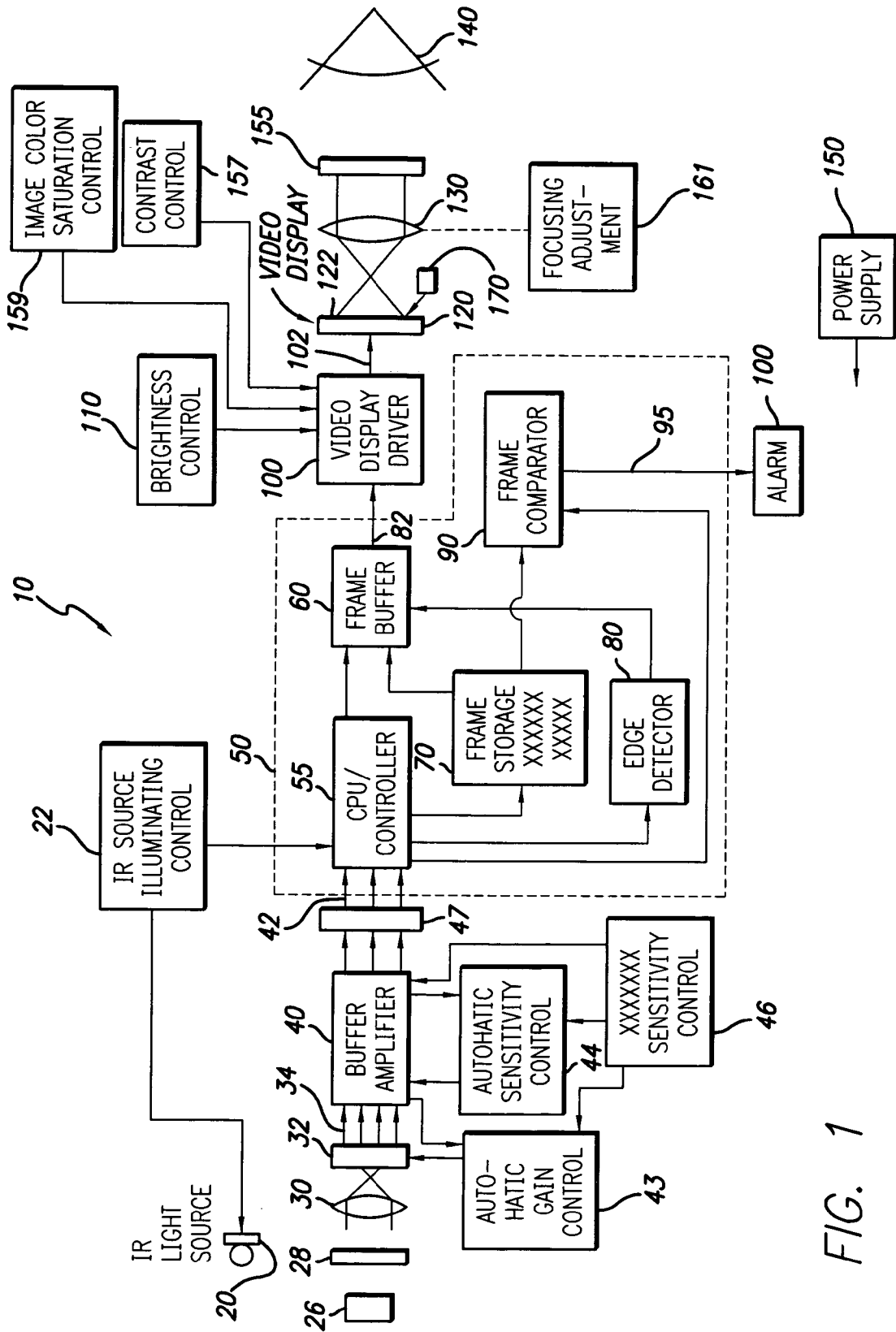

FIG. 1

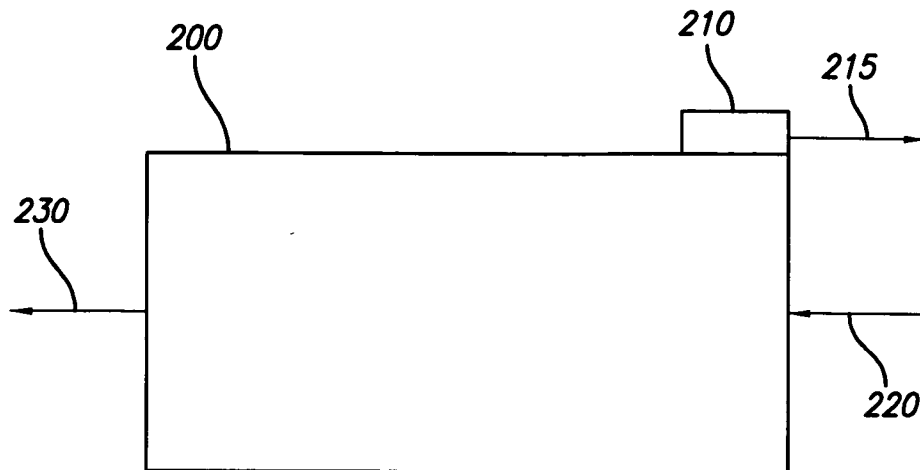

FIG. 2

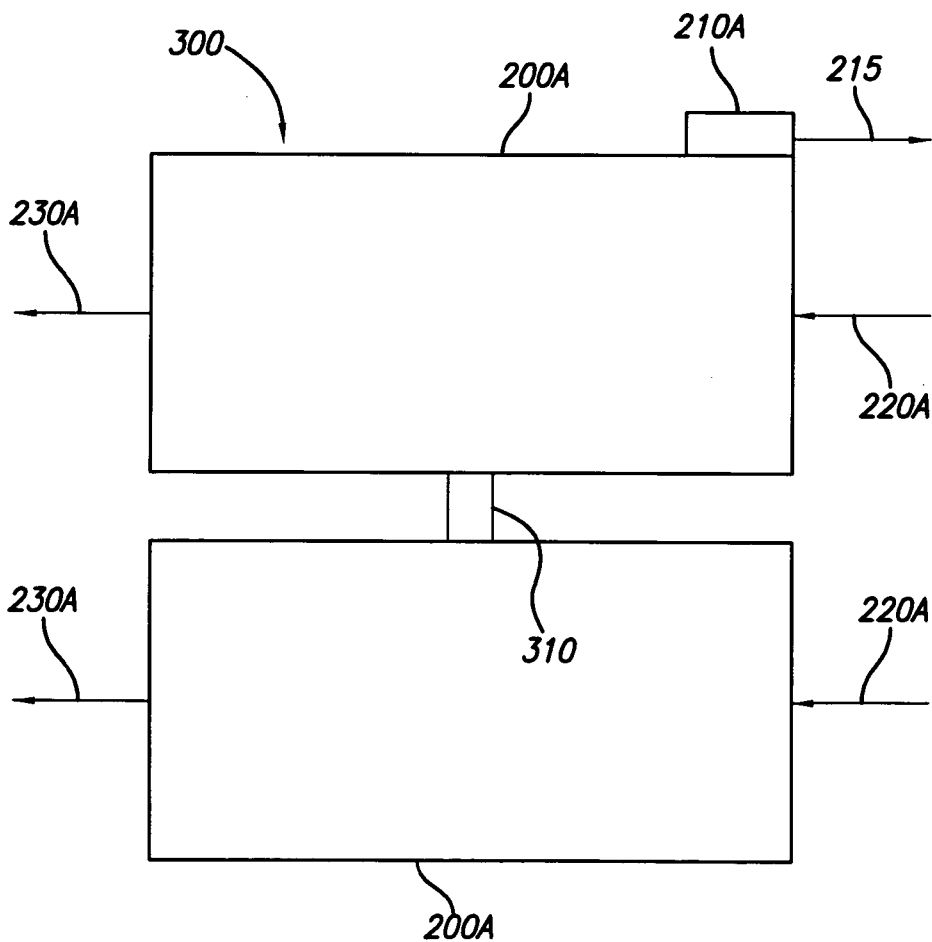

FIG. 3a

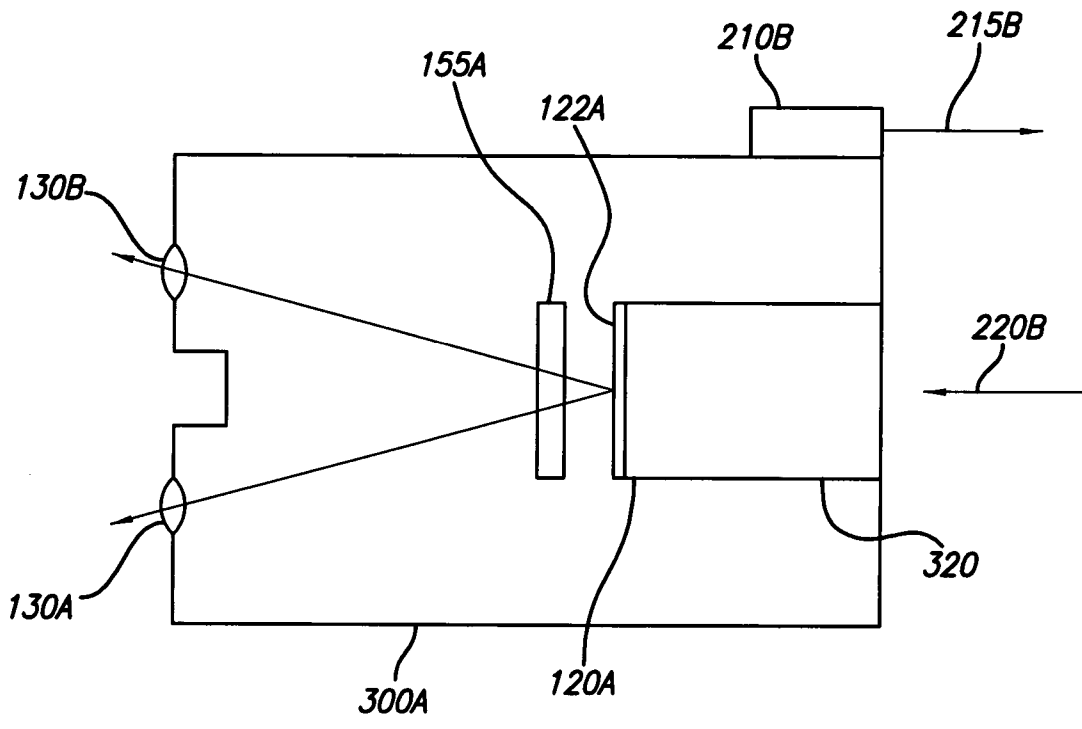

FIG. 3b

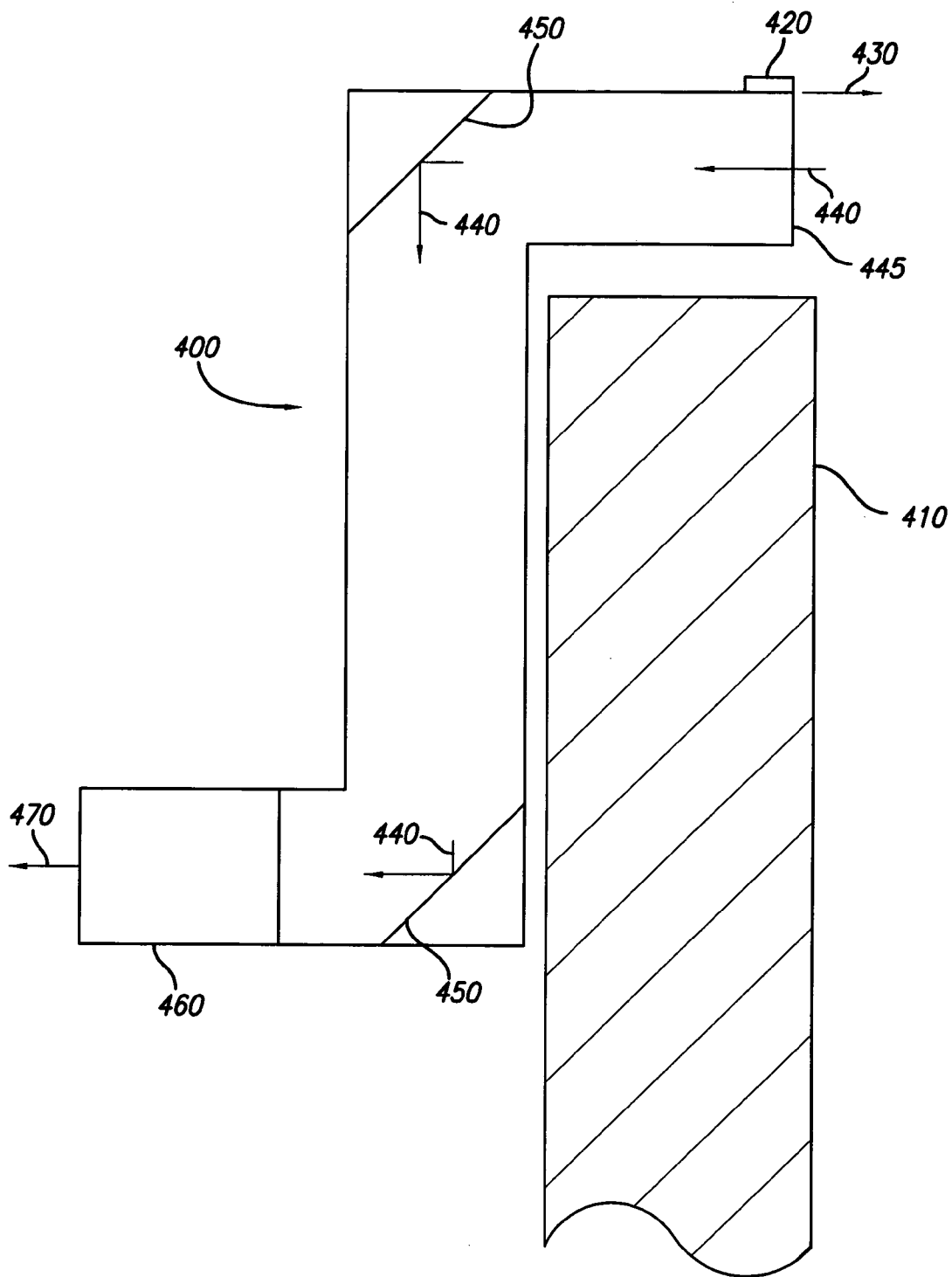

FIG. 4

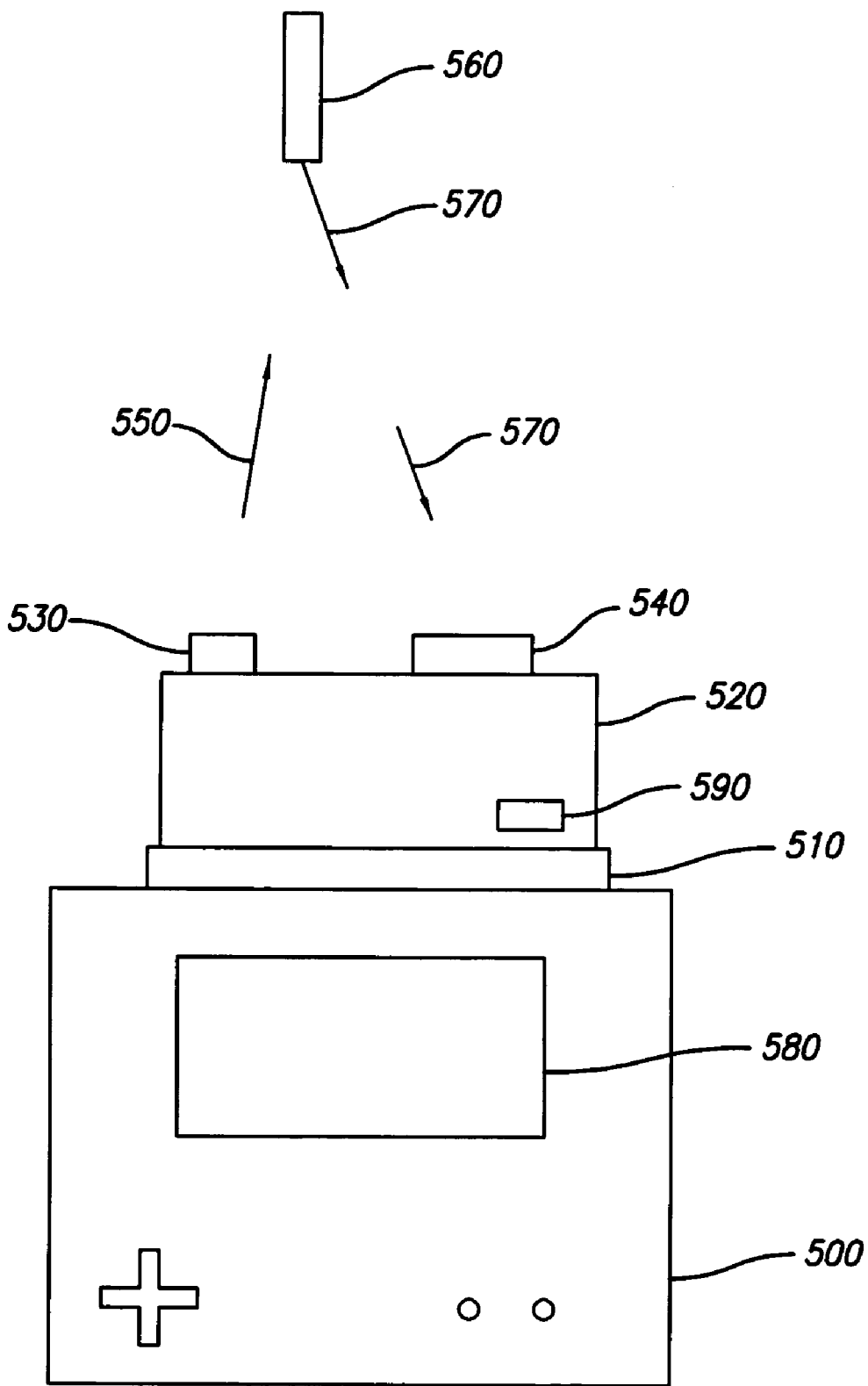

FIG. 5

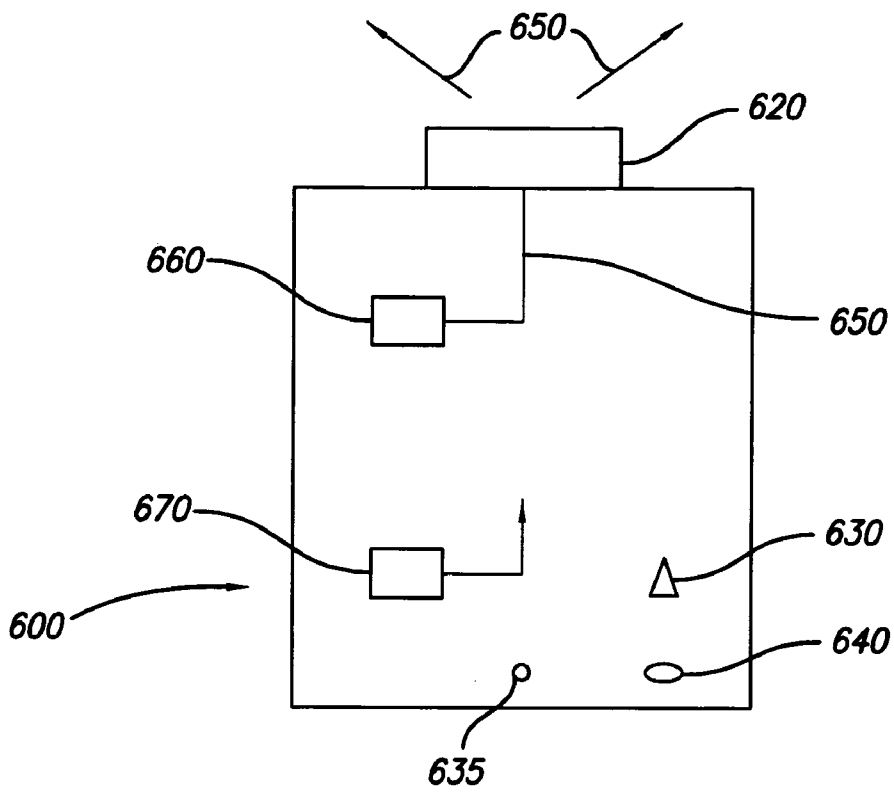

FIG. 6

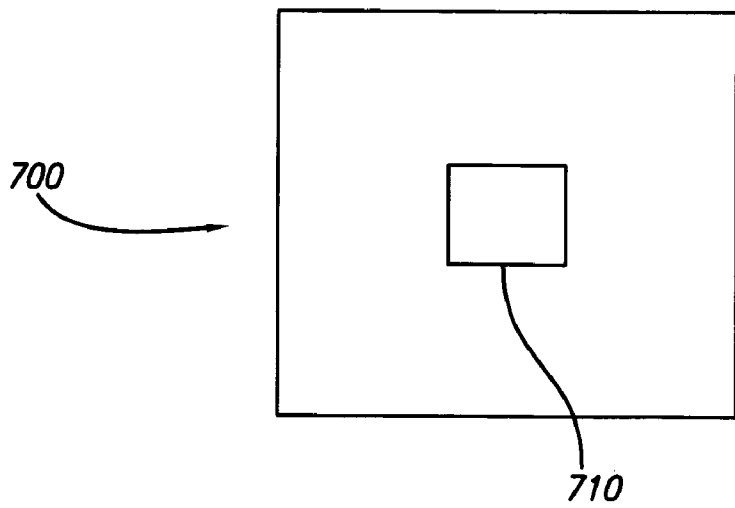

FIG. 7

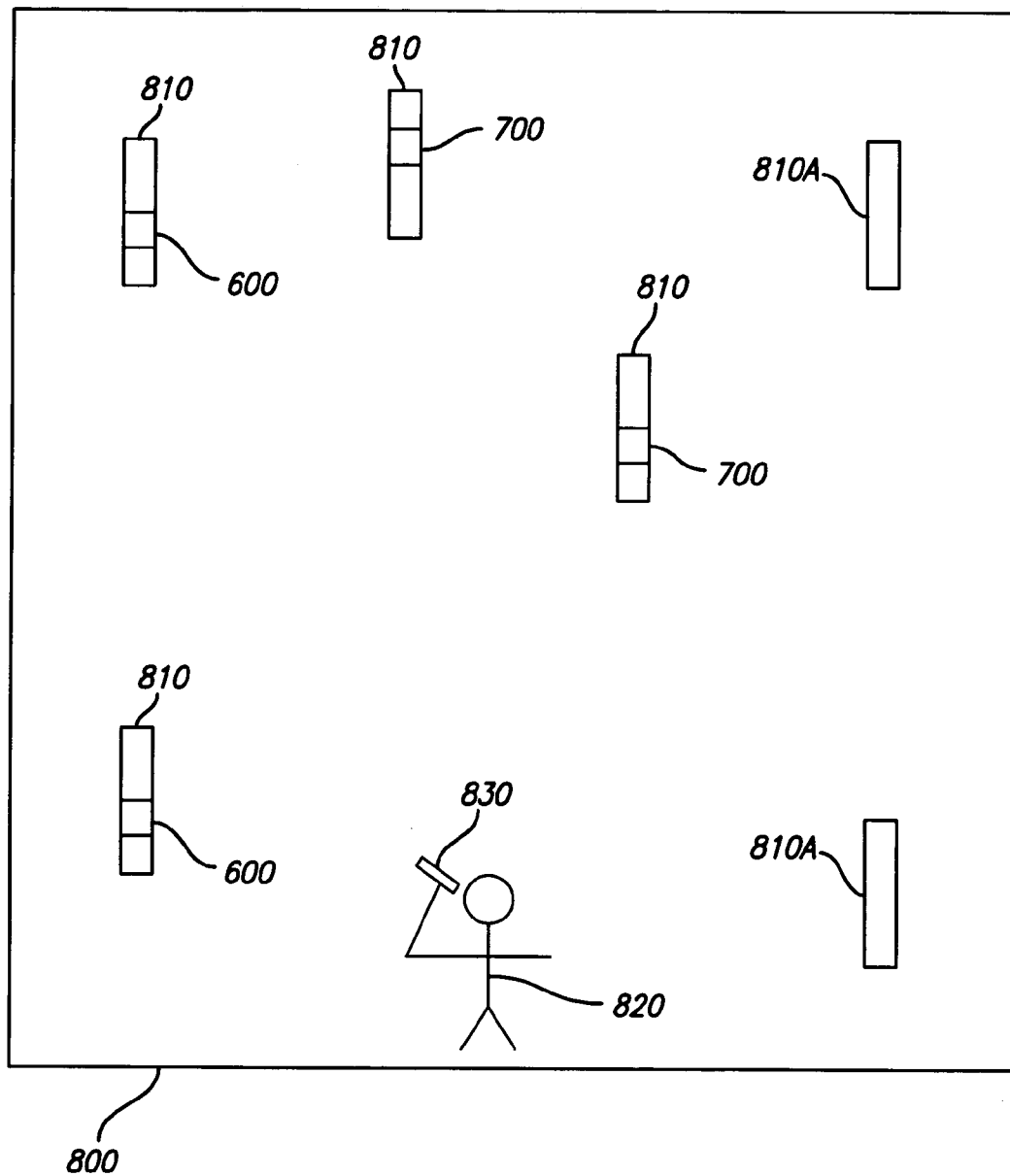

FIG. 8

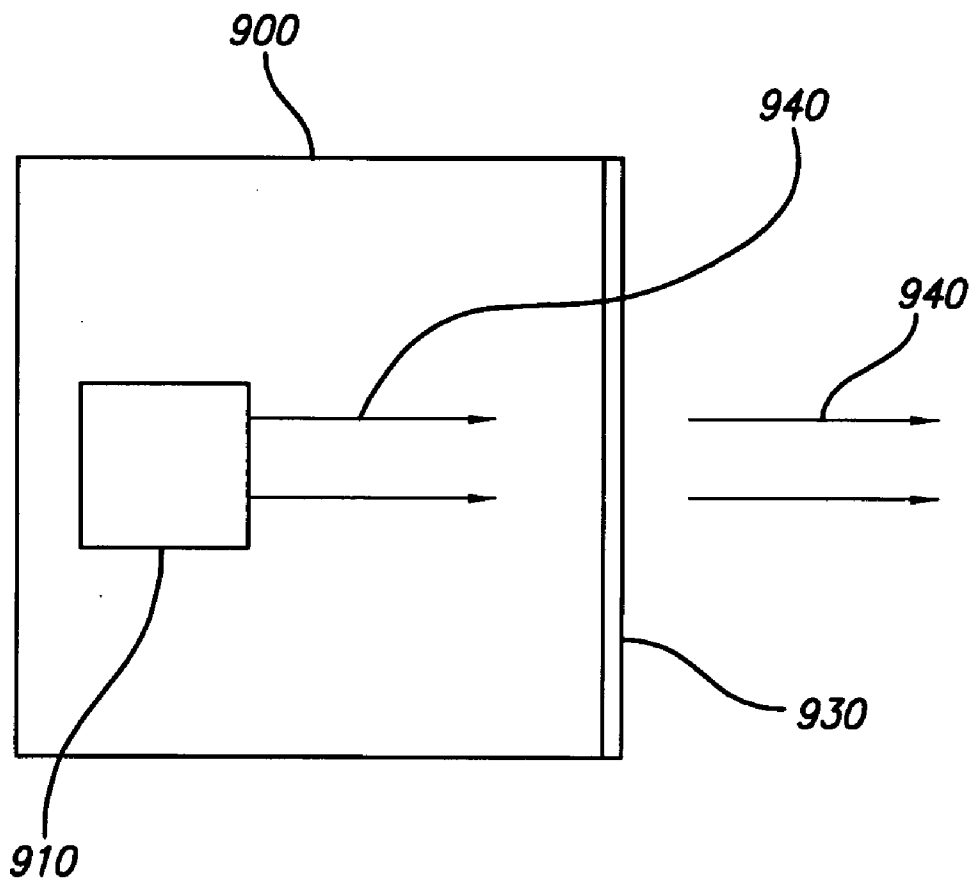

FIG. 9

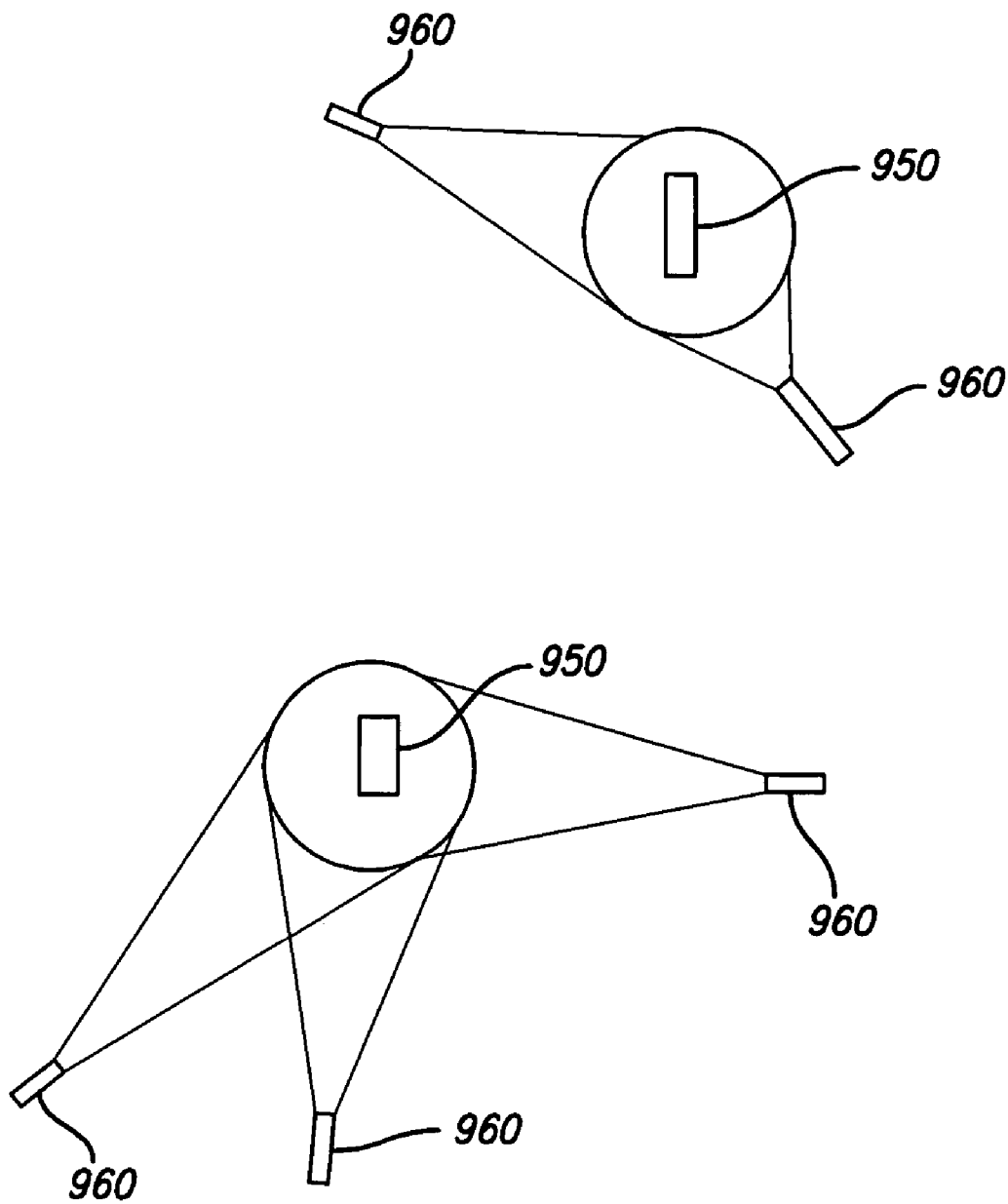

FIG. 10

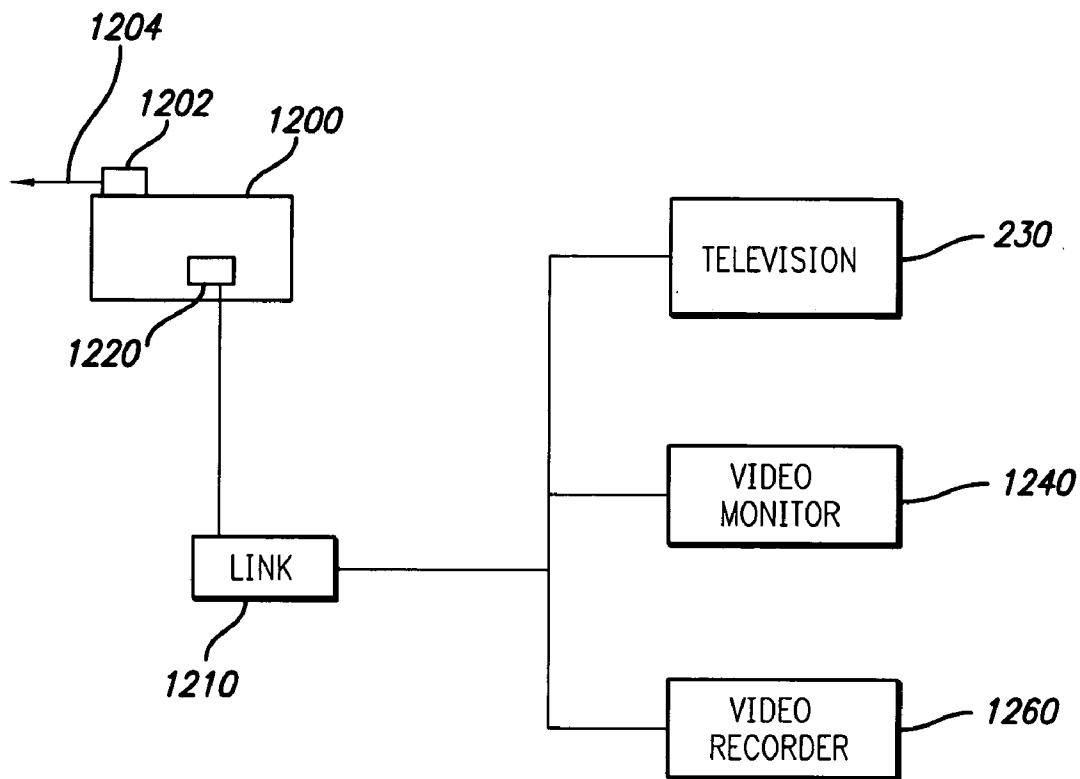

FIG. 11

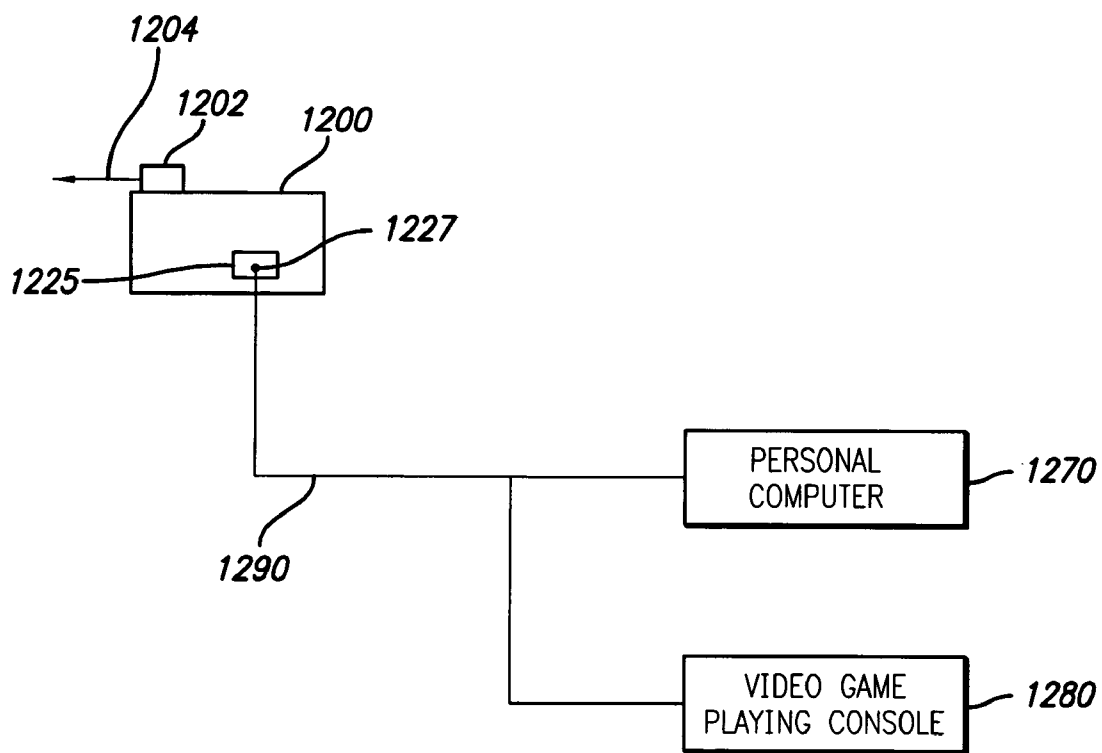

FIG. 12

INFRARED TOY VIEWING SCOPE AND GAMES UTILIZING INFRARED RADIATION

[0001] This application claims priority of PCT/US03/14051, filed May 7, 2003, and U.S. Provisional Application 60/378,508, filed May 7, 2002, which is incorporated herein.

FIELD OF THE INVENTION

[0002] This invention relates generally to toys and games, and more particularly, to scope toys for viewing images of reflected or emitted infrared (IR) radiation light under ambient, low level and totally absent visible light conditions and games utilizing such toys.

[0003] There are presently available night vision devices used by the military and for other applications, which through photo electronic multiplication or amplification techniques amplify ambient light and project a viewable image for the user in low light conditions. These devices can be found in military surplus stores, outdoor equipment catalogs, and the like. These devices generally utilize a photo multiplier/light amplifier imaging tube that produces an image on a small, phosphor coated surface viewing screen, which is viewed by way of an ocular eyepiece. The image depicted is usually green and is magnified by a lens so that a larger image is observed by the user.

[0004] These types of devices do not utilize infrared light. Rather they work under very low light level conditions, such as moonlight, ambient light from street lamps, windows, starlight etc. Low level incoming light to the night vision device is focused by a lens onto a photosensitive surface. The photons of light impinging upon the photosensitive surface at low energy levels cause electrons to be emitted by the photosensitive surface within the light amplification tube by way of the well-known "photoelectric effect" found in certain materials. These emitted electrons are then accelerated by a high voltage electric field and guided by focusing electric and/or magnetic fields onto a target surface, which is coated with a phosphoric material. When the accelerated electrons hit the phosphoric material, the phosphoric material converts the electrons into photons in the physical visible light spectrum, which may be viewed by the human eye. The phosphoric material generally used emits a light in the green color portion of the visible light spectrum.

[0005] The resultant image on the phosphoric material due to a low signal to noise ratio is usually grainy, but provides visual indication of objects such as persons, animals, structures, etc., in the viewing field of the night vision device.

[0006] Because of the costs of photo multiplier/light amplifier imaging tubes and the high voltage required to operate such imaging tubes, this technology is not suitable or safe for a toy product.

[0007] There are presently available very expensive commercial products for viewing infrared light that convert it to the visible light part of the electromagnetic spectrum, such as products that are used by firefighters to observe flames through smoke by means of detection of the infrared energy radiated by the flames. Also available, are expensive infrared detectors used to detect heat "leaks" from a house or building that are used as part of energy audits to lower energy usage by detecting heat leaks. Similar expensive devices have been used by law enforcement to detect unusual heat radiation (due to internal lighting) from build-

ings in which cultivation of illegal plants may be occurring. These devices are very expensive. These devices also do not provide infrared illumination of a scene.

[0008] Products have been known which utilize colored visible light to illuminate a scene and simulate a night vision scope. It will be understood that the electromagnetic (EM) spectrum includes certain wavelengths of EM radiation in approximately the 7,000 to 4,000 Angstrom wavelength bands, which is visible, i.e. visible light that humans can observe, and certain other longer wavelengths of EM radiation in approximately the 10,000 to 7,000 Angstrom wavelength bands described as infrared (IR) light, which cannot be seen or perceived by the human eye, although it can be felt or sensed sometimes as heat.

[0009] U.S. Pat. No. 6,116,744 (the "744 Patent) discloses toy glasses or goggles, which include a visible light source such as light emitting diode(s) in the visible portion of the electromagnetic spectrum positioned proximate to the eye(s) of the user for illuminating a scene, and makes no mention or use whatsoever of infrared light, i.e., light in the non-visible portion of the electromagnetic spectrum. The goggles utilize colored filters and/or lenses for simulating the appearance of a night vision scope. The '744 Patent discloses that a visible light sensor and processing electronics may be used to detect reflected visible light. When reflected visible light is detected by the sensor and the processing electronics, the user may be alerted by various means including a tone, warning message, or by changing how the lights are controlled. However, there is no mention of any actual image being formed or seen to become visible and no means to implement the aforesaid electronics is disclosed in the '744 Patent.

[0010] Night vision goggle simulators have also employed electronically controlled liquid crystals positioned in the optical path. U.S. Pat. No. 5,413,483 discloses such a construction. Training devices in the form of simulated night vision goggles, which employ polarizers and colored filters to give the impression of night vision viewing when viewing an illuminated scene such as in U.S. Pat. No. 4,202,601, are also known. Other night vision goggle simulators are also disclosed in U.S. Pat. Nos. 3,722,985; 4,337,044; and 5,420,414. In U.S. Pat. No. 5,742,939 play costumes used with real or simulated night vision devices, LEDs as light sources and IR sensors are disclosed.

[0011] The Applicant is not aware of any night or low light level viewing scope toy, which utilizes reflected or emitted infrared light. Applicant is also not aware of any toy, which emits infrared light and processes the reflected infrared light so that a scene may be viewed. A toy that processes infrared light for viewing would be interesting and entertaining to children and to adults. Such a toy may be used to view scenes at night or low visible light conditions and can also be used to play games, which involve the location of various objects in low visible light conditions by means of a view scope toy. Such a toy may also be used to view scenes in the darkness of night and under daylight conditions, and also in places or locations of darkness even during daylight hours such as dark rooms, basements, caves, tunnels, and similar places. Applicant's invention is not restricted to use at night.

[0012] Presently, children and others have enjoyed games such as treasure hunt, laser tag and other games under visible light conditions. Such games include the location of persons/ or objects under ambient visible light conditions.

[0013] Games under low visible light conditions have been hampered because the level of ambient visible light under certain conditions has been insufficient to produce an enjoyable game environment. Such games under low illumination ambient visible light conditions suffer from the problem of reduced visibility.

[0014] From the foregoing discussion, important aspects of the technology used in the field of the invention remain amiable to useful refinements.

SUMMARY OF THE DISCLOSURE

[0015] The present invention introduces many refinements and improvements over the present state of the art. In the preferred embodiments, the present invention has several aspects or facets that can be used independently, although they are preferably employed together to optimize their benefits.

[0016] In a preferred embodiment of its first facet or aspect, the invention is a view scope toy capable of receiving and processing electronically received infrared light signals and converting the infrared light signals to a visible light image or display for viewing or recording for later viewing. The view scope toy has an IR transparent image input-focusing lens for focusing the incident infrared light or EM energy on an infrared photoelectronic image sensor or sensor array or matrix. It also includes analog, digital, or combinations of analog and digital electronic signal processing means for processing the electrical output of the infrared sensor and a video display screen or viewing surface or image output device for viewing and displaying the scene in visible light to the eye or eyes of a person or persons.

[0017] In another preferred embodiment of the invention, a source of infrared illumination is included which infrared illumination source may or may not be integral with the infrared receiving portion of the scope toy.

[0018] In another preferred embodiment of the invention, an optional focusing lens is positioned between the video display screen and the eye of the user to focus and enlarge the image on the video display screen.

[0019] In another preferred embodiment, the display screen is a self-lighted (by phosphor emission) monochrome, or color miniature cathode ray tube ("CRT") screen or a monochrome or color back or front lighted liquid crystal display ("LCD") screen or a photonic emission screen using organic light emitting diodes (OLED).

[0020] In another preferred embodiment, a translucent red or green acetate or mylar color filter or gel is located between the viewing screen and the viewer's eye or eyes, which colors the viewed image to resemble an expensive night scope viewer utilizing photo amplifiers, which typically utilize green phosphors. Other colors beside green can also be used.

[0021] In another preferred embodiment of the invention, an infrared light source is present for illuminating the scene with infrared light, which is reflected from the objects in the scene to increase the infrared light energy incident upon the infrared photo sensor in the infrared scope toy.

[0022] In another preferred embodiment of the invention, the electronic processing of the electrical output of the

infrared sensor is capable of image averaging over time to provide a more sensitive device with greater range, i.e., the invention is able to provide acceptable images for viewing of objects that are a greater distance from the viewing scope. Also, darker or weaker images can then be seen and become visible by the increased sensitivity. In addition to basic image averaging, other image processing functions such as contrast enhancements, edge detection and other methods well known to those skilled in the art of digital image signal processing can be used.

[0023] In another preferred embodiment, an infrared light source is capable of being "flashed" or "strobed" at intervals and the scope is synchronized with the infrared source so that the scope processes receive infrared signals during the period of the "flash" or "strobed" infrared illumination to produce an image of the visible light which has a higher signal to noise ratio and greater definition and clarity.

[0024] In another preferred embodiment, audio alarms or notification signal generating circuits and/or processing algorithms are electronically connected to the video processing circuitry so that an audio signal may be generated in response to a change in the pixels in the image above a predetermined level corresponding to a change or movement of persons or objects in the scene being viewed.

[0025] Still another embodiment of this first facet or aspect is an input sensitivity control or controls which allows for the user to manually, automatically or semi-automatically adjust the sensitivity of the IR receiver and signal processing portion for optimum sensitivity to weak or low level infrared light, thereby increasing the range of operation of the view scope and the operating sensitivity to infrared light.

[0026] In preferred embodiments of its second major independent facet or aspect, the invention is a night or low visible light level view scope game for searching and locating objects. It includes the step of illuminating a scene with infrared light, which is not visible to the human eye. Other steps comprise the detection of the infrared light and converting the infrared light to light in the visible spectrum. Another step is observing the visible spectrum light and locating the object when it is depicted by visible spectrum light.

[0027] Another embodiment of the invention comprises the steps of emitting an infrared light and locating IR reflective devices (proximate or affixed to a predetermined object and/or person) so as to aid a game participant in locating the object and/or person.

[0028] Still another embodiment of the invention comprises the step of locating a pulsed or continuous IR transmitter proximate and/or affixed to a predetermined object and/or person so as to aid a game participant in locating the object and/or person.

[0029] Yet another aspect of the invention comprises the step of illuminating a supplemental IR transmitter or transmitters to illuminate a scene to improve the view of the scene in the view scope.

[0030] Other aspects and facets of the invention will become apparent to those having ordinary skill in the art upon reading the detailed description of the preferred embodiments set forth below.

BRIEF DESCRIPTION OF THE DRAWINGS

- [0031] The drawings are schematic and not necessarily to scale.
- [0032] FIG. 1 is a schematic diagram of a preferred embodiment of the invention;
- [0033] FIG. 2 is a diagrammatic view of an embodiment of the invention;
- [0034] FIG. 3a is a diagrammatic view of an embodiment of the invention in the form of a binocular;
- [0035] FIG. 3b is a diagrammatic view of a second embodiment of the invention in binocular form;
- [0036] FIG. 4 is a diagrammatic view of our embodiment of the invention in the form of a periscope;
- [0037] FIG. 5 is a diagrammatic view of an embodiment of the invention as a plug-in unit to a personal digital assistant, hand-held video game such as Game Boy Advance, or similar device;
- [0038] FIG. 6 is a diagrammatic view of an embodiment of an infrared beacon for use in playing games;
- [0039] FIG. 7 is a diagrammatic view of an infrared reflector for use in playing games;
- [0040] FIG. 8 is a diagrammatic view of a player in a play area using the infrared toy scope to locate infrared beacons and/or reflectors;
- [0041] FIG. 9 is a diagrammatic view of an infrared light source;
- [0042] FIG. 10 is a diagrammatic view of a target or targets being illuminated by one or more portable infrared source or sources.
- [0043] FIG. 11 is a diagrammatic view of yet another embodiment of the invention.
- [0044] FIG. 12 is a diagrammatic view of still another embodiment of the invention.

DETAILED DESCRIPTION OF THE PREFERRED EMBODIMENTS

[0045] Applicant incorporates by reference the "Summary of the Disclosure" set forth above in its entirety. Further scope of applicability of the present invention will become apparent from the detailed description given hereinafter. However, it should be understood that the detailed description and specific examples, while indicating preferred embodiments of the invention, are given by way of illustration only, since various changes and modifications within the spirit and scope of the invention will become apparent to those having ordinary skill in the art from this detailed description.

[0046] One preferred embodiment of the night view scope toy 10 is disclosed in schematic form in FIG. 1. The night view scope toy 10 utilizes infrared light, which is not in the visible portion of the electromagnetic spectrum. In operation, the night view scope toy may utilize IR light emitted by an object or person or warm-blooded animal (such as a mammal) in a scene or a scene may be illuminated by operation of an infrared light source 20. It will be understood that there may be a plurality of infrared light sources and that

each time a single infrared light source is mentioned, a plurality of infrared light sources may be utilized. The infrared light source 20 is controlled by an infrared source illumination control 22, which regulates the electrical power, which operates the infrared light source 20. The infrared light source 20 may be an infrared light emitting diode (IR LED), a conventional incandescent light source with an infrared filter, IR floodlight, or such other infrared light sources as are presently on the market and known to those having ordinary skill in the art. The infrared source illumination control 22 is also electrically coupled to the CPU/controller 25 as is described in detail herein below.

[0047] It will be understood by those having ordinary skill in the art that the infrared light source may be a separate, independent unit from the remainder of the night view scope toy and may have a binary (on/off) control or an analog control which is capable of adjusting the infrared light output of the light source to different levels. The control may also be capable of synchronizing and controlling the timing of the infrared light, such as an infrared flashbulb, or infrared strobe light. Such a control may also be coupled and synchronized with the image sensing and/or processing portion of the invention so as to increase the sensitivity and range of the view scope. It will be understood that a plurality of infrared light sources may be utilized in such an embodiment. The IR light illumination sources can also be pulsed to convey data and information in binary data forms which can be detected and used in games, identification, and other useful purposes.

[0048] The optical input of the night view scope toy 10 comprises an infrared filter 28 (which is optional), an input focusing lens 30 and an infrared sensor 32. The infrared sensor 32 may be any one of a number of semiconductor optoelectronic devices commonly available today, such as a charge coupled device (CCD), CMOS image sensor, a dynamic RAM (DRAM) IC chip the surface of which is exposed to incident light energy (photons) in visible and/or infrared wavelengths, or any other similar optoelectronic device.

[0049] In this embodiment, the scene to be viewed comprises a target 26, which may be capable of radiating infrared light or reflecting infrared light emitted by the infrared light source 20. The infrared light emitted from or reflected from the target 26 passes through the infrared filter 28. The infrared filter 28 is composed of a material transparent to infrared electromagnetic energy, but substantially opaque to light outside the infrared spectrum passband of the filter. Typical infrared filter materials are glass with thin film coatings, acetate or mylar films containing dyes and other filters which form a band pass filter in the optical wavelengths of electromagnetic energy so as to allow infrared energy to pass through with a low level of attenuation, but which highly attenuates visible light energy. The infrared filter 28, prevents visible light from entering and ensures that the infrared scope toy 10 will respond only to infrared light. Those having ordinary skill in the art will recognize that the infrared filter 28 is not a necessary feature of the view scope toy but provides for improved operation of the view scope toy under certain conditions by increasing the signal to noise ratio of the view scope toy. The filter can be controlled by a mechanical button and/or electrical motor so as to be positioned or removed from the optical path. This permits the toy viewing scope to be used with or without the IR filter,

which can produce better quality results depending on conditions. More than one IR filter type can be included by a caddie rotating or sliding mechanism. Different IR filters with various optical passbands and wavelengths can alter and improve the received images for optimum viewing under a wide variety of conditions.

[0050] The input focusing lens **30** focuses the infrared light from the scene, after it has passed through the infrared filter **28**, onto the infrared sensor **32**. The infrared sensor **32** may be a charged coupled device (CCD), CMOS, or DRAM chip or other suitable infrared reactive device. The infrared sensor is reactive to infrared light in proportion to the intensity of incident infrared light.

[0051] Typically, an infrared sensor, such as a CCD, CMOS or DRAM chip, have an array of pixels on its surface. Typical pixel densities and resolutions may range from 50 to 200 dots per inch (dpi) and from 60 pixels×60 pixels to 640 pixels×480 pixels resolution. For the invention, a preferred embodiment utilizes a low resolution, low dpi CMOS monochrome image sensor such as the CA201A monochrome CMOS image sensor from Sun Plus Technology Co., Ltd., headquartered at Service Park, Hsin Chu, Taiwan, ROC. This optoelectronic semiconductor image sensor has an effective array size of 160 pixels×120 pixels with each pixel 7×7 μm in dimensional size. Each pixel generates a current proportional to the intensity of the light incident upon it. Such CMOS sensors are primarily used for visible light image sensing, but many also are sufficiently sensitive to infrared to provide acceptable results. Each pixel generates a current in reaction to the intensity of the infrared light striking the pixel. Thus, the infrared sensor **32** generates a plurality of electrical signals, each signal representing the intensity of the infrared light striking the infrared sensor in a predetermined pixel area.

[0052] The electrical outputs of the infrared sensor **32** are of an exceedingly small current, which must be amplified. Accordingly, the electrical outputs **34** of the infrared sensor **32** are electrically connected to a buffer/amplifier **40**, which serves to amplify the small electrical signals from the infrared sensor **32**. The amplifier **40** is connected to an automatic sensitivity control **44** and a manual sensitivity control **46**. The manual sensitivity control is operable by the user and adjusts the amplification of the buffer amplifier **40** to obtain an optimal visual image as disclosed below. The automatic sensitivity control **44** attempts to maintain the electrical output of the buffer amplifier **40** to the predetermined level as set by the manual sensitivity control **46** as the electrical output signals **34** from the infrared sensor **32** vary due to any change in the level of intensity of infrared light entering through the infrared filter **28** from the target **26**.

[0053] An automatic gain control (AGC) **43** operably connected directly to the output of the IR sensor **32** or, in an additional preferred embodiment (shown in the drawing), operably connected to the output of the IR sensor **32** through the buffer/amplifier **40**. The output of the AGC is fed back to the image sensor **32** so that the AGC is able to change the bias current or voltage levels of the image sensor **32** so as to increase or decrease the amplification of the pixel current or voltage. The automatic gain control **43** may also be adjusted by the manual sensitivity control **46**. As will be understood, the manual sensitivity control **46** may have a plurality of user interface adjustment controls.

[0054] The signal processing unit **50** is comprised of a central processing unit/controller **55** (which contains the stored program instructions for operating the controller, operating registers and working memory for computations, and input and output signal and control lines), and other electronic circuit elements such as a frame buffer **60**, frame storage memory **70**, edge detector **80**, and frame comparator **90**, as well as other standard circuit elements for controlling the operation of all the internal elements.

[0055] Those having ordinary skill in the art will appreciate that the functions of frame storage memory, edge detection and frame comparison may be accomplished with software. Accordingly, the function in an alternative preferred embodiment, performed by the edge detector **80** and frame comparator **90**, which are discrete electronic circuits, may also be realized by utilizing computer software programs running on the main CPU/controller and micro controller system of the toy viewing scope. In this embodiment of the invention, digital data representing image elements are stored in portions of a read/write RAM and the control program operates and performs computational manipulations of the data to realize the various image processing functions and features. In such an embodiment, algorithms known to those having ordinary skill in the art are applied to the image data through the operation of the CPU/controller **55**. It will also be appreciated to those having ordinary skill in the art that the frame storage memory **70** may be part of the memory of the CPU/controller **55**, but is shown as a separate block in **FIG. 1** for clarity of illustration. Those having ordinary skill in the art will appreciate that the memory of the CPU/controller **55** and the frame storage memory **70** may occupy the same memory storage media, but be resident at different addresses.

[0056] The amplified output signals **42** from the buffer amplifier **40** are electrically connected to the CPU/controller **55**, by means of analog to digital (A/D) converters **47**. The CPU controller **55** controls the signal processing of the signal processor **50**. The central processing unit/controller **55** is capable of routing the output **42** of the A/D converters **47** to the input of the frame buffer **60**. Alternatively or additionally, the CPU controller **55** may route the output **42** of the D/A converters **47** to the frame storage memory **70**, which in a preferred embodiment is a readable and writeable random access memory (RAM). The function of the frame storage memory **70** is to store and aggregate values of output **42**. For example, when the level of infrared light entering the infrared filter **28** and striking the IR sensor **32** is low, the electrical outputs **34** of the infrared sensor **32** will also be low as will be the outputs **42** of the A/D converters. The frame storage memory **70** is capable of adding the electrical values from each pixel of one frame to one or more electrical values from the same pixels in successive frames of data so that the electrical values per pixel are increased frame by frame. This is analogous to time lapse or double or multiple exposure using conventional chemical photographic methods so that in extremely low infrared light situations, there is additional amplification of the signals by means of aggregating each of the electrical values of the pixels. After successive frames have been stored in the frame storage memory **70** and the electrical values for each respective pixel have been respectively aggregated, the output of the frame storage memory **70** is electrically operable connected to the frame buffer **60**.

[0057] Additionally, the CPU/controller is capable of routing the electrical signals 42 from the A/D converters 47 to the edge detector 80. The edge detector 80 performs logical operations on the pixel data such as exclusive OR(XOR) and/or other digital logic and comparison operations. The output of the edge detector 80 may also be routed to the frame buffer 60.

[0058] The CPU controller is also capable of routing the electrical output 42 of the A/D converters 47 to a frame comparator 90. The frame comparator 90 records in memory a frame of data and then compares the reference frame to subsequent frames of data. Deviations in pixel data between the reference frame and subsequent frames of video can trigger an alarm or other user notification signal 95 if the difference between the reference frame and subsequent frames is equal to or greater than a predetermined magnitude or falls outside or inside a predetermined criteria. The alarm signal 95 generated by the frame comparator 90 is electrically coupled to an alarm 100 which may be an audio, video and/or visual alarm, notifying the user of a change in the scene.

[0059] When a frame of video data is received by the frame buffer 60, the frame buffer 60 generates a corresponding frame output signal 62.

[0060] Next referring to the video output portion of the night view scope toy 10, there is disclosed a video display driver 100, brightness control 110, an optional color filter element 155, an optional image contrast control 157, an optional image color saturation control 159 (in the case of color video displays), a video display 120, an optional optical image viewing focusing lens 130, with an optional focusing adjustment control 161. The optional color filter element 155 may also be located between the video display screen 122 and the optional image viewing focusing lens 130, in an alternative embodiment of the invention.

[0061] The video display driver 100 receives video frame output signal 62 from the frame buffer 60. The video display driver 100 operates to provide video frame drive data 102 to the video display 120, which corresponds to the respective video frame output signal 62. The video display 120 may be an LCD or another type of video output device. The video display 120 may be black and white, monochrome or color LCD, CRT, organic light emitting diode (OLED) or other video display device and has a video display surface 122, which generates an image corresponding to the video frame drive data 102. The video display surface 120 may be front, side or back lit, using LED, incandescent lamps or various other light sources of various colors, such as by screen light source 170.

[0062] A preferred embodiment of the invention uses a reflective black and white LCD video display which is illuminated from the front and/or sides, with red, green, yellow or other color LEDs, so as to simulate the appearance of a real, military type IR view scope using green phosphors, or the red light condition of a submarine or an entertaining yellow light condition is utilized. However, it will be appreciated that any other color of optical viewing filters, such as blue, purple, or a combination of various color filters and/or displays may be used for effects.

[0063] An output focusing and enlargement lens 130 is provided so that the image on the display surface 122 of the

video display 120 is enlarged and may be focused so that it is capable of being perceived by the eye 140 of the user. Should it be desired to increase the brightness of the image on the display surface 122 of the video display 120, a brightness control 110, as well as optional contrast control 157, color saturation control 159, and the other video controls discussed above, are provided which are electrically coupled to the video display driver 100 to increase the magnitude of the electrical signal 102 from the video display driver 120. These controls function together to improve the apparent sensitivity of the view scope toy by optimizing the video output display image. As will be understood by those having ordinary skill in the art, the brightness of the image on the display surface 122 will be proportional to the magnitude of the video frame drive data 102 over their respective operating ranges.

[0064] The electronic components and circuits are energized by means of a power supply 150, which provides power for all of the circuits and devices requiring electrical power. The power supply may itself receive power from batteries or from standard 110/120 volt common utility service electrical supply, as well as from vehicles such as cars, trucks and boats, which provide a 12 volt DC power system. As is well known to those having ordinary skill in the art, these electrical power sources may be converted to an electrical voltage suitable for operating the circuits of the night view scope toy.

[0065] The use of manual input and/or output sensitivity and user adjustment controls to the view scope toy is an important aspect of the invention. In addition to making the use of the view scope toy fun with a lot of user control and interaction provided, the inclusion of these controls has a very favorable impact on the manufacturing process of the invention. For example, electronic components such as resistors, capacitors, and other circuit elements can be of a very wide value, with a wide range of tolerance. Also, there will be very little need, or none at all, for factory calibration of the elements within the circuits of the view scope toy. Because the user can make the adjustments for optimum sensitivity and operation, there is far less need for the cost and expense of factory technicians to do so when the product is manufactured. This leads to a very beneficial situation for obtaining high yield manufacturing results which lead to lower costs.

[0066] Another preferred embodiment of the invention is to utilize software computational techniques instead of, or in addition to, actual, dedicated electronic circuits, such as edge detector 80 and frame comparator 90. In such an embodiment, the CPU controller 55 receives digital frame image data of the scene. The software in the CPU/controller operates on the digital image frame data and performs the computational activity to create information corresponding to a frame having the edges of the objects in the scene outlined. Similarly, successive image frame data may be received by the CPU/controller, and the digital frame image data may be stored so that comparisons may be made between pixels in successive or multiple frames of image data so that the output of the CPU/controller will be a frame of image data, which is the aggregate of several input frames. In this embodiment, the output frame would correspond to a time lapse photograph made by standard photographic techniques. Similarly, various frames of input image data may be compared and if the image data changes or

varies by more than a predetermined amount or quantity, representing motion or movement in the scene. The CPU/controller may send a signal to an audio and or video alarm in response to the change in the image. Programs implementing these functions are within the skill of those having ordinary skill in the art. Portions of such actual/dedicated electronic circuits may also be replaced by software control programs so that the software control programs perform some, but not all of the functions of the portions of the actual dedicated electronic circuits, which have been replaced.

[0067] In another embodiment of the invention, the electrical output 42 of the A/D converters 47 is connected directly to the input of the video display driver 100, although the image processing and enhancement functions will not be fully realized in this embodiment. The performance of the toy view scope will still be acceptable, but the quality will not be as high as with the use of the signal processing unit 50.

[0068] In yet another embodiment of the invention, it is also possible to connect the analog signal output of the buffer amplifier 40 directly to an analog input version of the video display driver 100. Performance of the toy view scope in this embodiment will be useable, but again it will lack the advanced image processing functions provided by the signal processing unit 50.

[0069] Referring now to FIG. 2, there is disclosed therein a diagrammatic view of the invention in monocular form. The infrared toy scope 200 contains the lens, electronic circuits, and video display screens (not shown), which have been disclosed and discussed above. Also, the infrared toy scope 200 has an IR transmitter 210 for illuminating a scene with infrared illumination 215. It will be understood that the IR transmitter need not be affixed to the infrared scope 200, but may be separate and apart from it. The infrared scope 200 receives reflected infrared light 220, which through the infrared image sensor, electronic circuits, and video display screens disclosed in detail above converts the infrared light to visible light 230, which can be viewed by the user.

[0070] Referring now to FIG. 3a, there is disclosed therein the invention in binocular form 300. The binocular form of the invention is essentially two monocular IR scopes 200A held together by a conventional binocular fastener 310. The conventional binocular fastener is well known to those having ordinary skill in the art. The binocular form of the invention requires a single IR transmitter 210A, which transmits infrared illumination 215A towards a scene. Reflected infrared light 220A enters the infrared binoculars and through the use of the aforesaid sensors, circuits, and displays a visible light 230A is produced.

[0071] Next referring to FIG. 3b, there is an alternative embodiment of the invention in binocular form 300A. The alternative embodiment of the invention comprises an IR transmitter 210B, which transmits infrared illumination 215B toward a scene. Reflected infrared light 220B enters the infrared binoculars and is received and processed by the sensors, circuits, and displays referred to generally in FIG. 3b as 320. These elements include a display screen 120A, having a display surface 122A upon which the image in visible light form appears. An optional color filter 155A is located proximate the video display 120A. A pair of output image focusing lenses 130A and 130B are mounted to the binocular housing and the distance between the lenses is

such that the user may simultaneously look through the two focusing lenses at the image on the display surface 122A of the video display 120A. Accordingly, this embodiment of the toy view scope in binocular form is less expensive than the above-identified binocular form, because it is not necessary to double each component to create the binocular form of the invention.

[0072] Next referring to FIG. 4, there is shown therein the invention in periscope form 400. The periscope 400 is positioned at the edge of a wall 410.

[0073] An infrared transmitter 420 transmits infrared illumination 430 towards the scene. Reflected infrared illumination 440 enters the input opening 445 of the periscope 400. Periscope 445 contains two mirrors 450, which reflect the IR illumination towards the IR scope 460. The IR scope converts the infrared illumination to visible light 470, which can then be seen by the user. It should be noted that the IR scope 460 may be unitary with the remainder of the periscope 400 or it may be a separate unit, which may be affixed to the remainder of the periscope by conventional fasteners. It should also be noted that it is possible that the IR transmitter 420 may be mounted within the periscope rather than to the outer surface of the periscope 400.

[0074] Next referring to FIG. 5, there is disclosed therein a display unit 500 such as a personal digital assistant, hand-held video game, such as a Game Boy Advance, or similar device. A connector 510 is a part of the device 500 and is capable of receiving a plug-in unit 520. The plug-in unit 520 has an infrared transmitter 530 and an infrared receiver 540. The infrared receiver transmits infrared illumination 550 toward a scene and the infrared illumination 550 will strike targets 560 in the scene such as target 560. Reflected IR illumination 570 from a target 560 in the scene will be received by the IR image sensor 540. The plug-in unit 520 contains the infrared image sensor, lens, and electronic circuits discussed above. By virtue of the plug-in with the device 500, the reflected infrared 570 is converted to visible light for viewing on the screen 580. The plug-in unit 520 may also contain an optional additional power source 590. It will be understood that the infrared transmitter 530 may be separate and apart from the plug-in unit 520 in an alternative embodiment.

[0075] Referring now to FIG. 6, there is disclosed therein an infrared beacon 600 having an infrared source 620. The infrared source 620 may be a single or multiple light-emitting diode or incandescent lamps with infrared filters as described in more detail herein. The infrared beacon includes a power source 670, start and stop switch 630, and control switches 635 and 640 for controlling the intensity and frequency of the infrared illumination 650. The infrared illumination 650 from the infrared transmitter 620 is controlled by an electronic control circuit chip 660. The control circuit chip 660 is electronically coupled to the infrared source 620 by means of connector 650. The electronic control chip is capable of controlling the intensity, and pulsing of the infrared source 620. The pulsing may be at defined intervals as set by the control 640 or may be random. Such control circuitry 660 is well known to those having ordinary skill in the art. The pulsed IR emission may also carry data and identification information by using PWM, PCM or other digital encoding methods well known to those skilled in the art.

[0076] Next referring to FIG. 7, there is disclosed therein an IR reflector 700, which has an infrared reflecting portion 710.

[0077] As will be disclosed herein below, the infrared beacon 600 and the infrared reflector 700 may be utilized in infrared games.

[0078] Now referring to FIG. 8, there is disclosed therein a diagrammatic view of a play area 800 which may be a room, a yard, a forest, a basement, or other play area. Within the play area 800, there are placed one or more or a series of targets 810 which comprise infrared beacons 600, infrared reflectors 700, or targets which do not comprise either an infrared beacon or a reflector, which are referred to as 810A. In an alternative embodiment, infrared beacons and/or infrared reflectors may be placed proximate to targets 810A.

[0079] A player 820 is in the play area and is utilizing the toy scope 830 in searching the play area. Multiple players may be present, each searching for targets 810 and/or 810A. The objective of the game is to find the targets. It will also be understood that a player may wear or carry an infrared beacon and/or target and that the other players may play a game with the toy scope of hide and seek, in which they attempt to locate the player wearing or carrying the infrared beacon and/or target.

[0080] Next referring to FIG. 9, there is disclosed therein in diagrammatic form an infrared light source 900, which may be a flood lamp, a flashlight, or other unit utilizing an incandescent light source 910. Within the infrared light source 900, there is an incandescent light source 910, generating light waves 920. The infrared light source 900 has an infrared band pass filter 930, which allows infrared electromagnetic radiation to pass through it, but which substantially attenuates visible light wavelength radiation. Accordingly, infrared radiation 940 exits the filter 930 and is capable of illuminating a scene. The infrared light source 900 may also be used in playing the infrared games described herein.

[0081] Next referring to FIG. 10, there is disclosed therein one or more targets 950 being illuminated by one or more portable infrared sources 960, simultaneously or sequentially in time and spatial coordinates, by one or more players. Players using the infrared toy scope may play a game wherein the objective of the game is to be the first person to illuminate one or more targets, or to have some or all of the game players illuminate one or more targets. Through the use of the infrared toy scope, the one or more targets may be located and through the use of the portable infrared sources 960, the game players illuminate one or more targets. Collectively the multiple infrared sources will increase the illumination power directed upon a target or targets, thereby increasing the range or distance by which a target can then be seen on the view scope toy. There can be one or more other players using the view scope toys in different positions and locations for viewing. Another game involves one or more scouts, each having a portable infrared source 960, by which they can singularly or collectively illuminate a selected target or targets, either simultaneously or sequentially, in time and spatial coordinates similar to the above. The target may in alternative embodiments have an infrared beacon and/or infrared reflector attached to it or in the target's vicinity.

[0082] As will be appreciated, one or more IR light sources 900A may also be used to implement the game, but

such sources are optional. One or more players with infrared toy scopes may search for one or more of the targets, which have previously been located within the play area. The objective of the game may be to be the first to locate a target or to locate the largest number of targets. Similar games are also possible.

[0083] Referring now to FIG. 11, there is shown an embodiment of the invention, wherein there is a physical separation between the elements of the infrared toy scope 1200 (having an IR source of illumination 1202 directing IR electromagnetic energy 1204 at a scene) and a video display by means of a link 1210. The link 1210 can be, for example, by means of video and audio wire cables, or by means of a wireless transmitter and receiver combination using modulated RF carrier signals.

[0084] By using wireless radio frequency (RF) signals, for example, as the link 1210 with associated modulators and demodulators, the received image can be displayed in a location separate from the input section to the view scope toy. Also, the view scope toy video display drive can include circuits 1220 to encode the video image into a television video standard such as NTSC, PAL, HDTV, or other well known standards so that the images received by the view scope toy can be viewed on a television 1230, video monitor 1240, or video recorder 1260 (for delayed viewing).

[0085] Another embodiment of the invention shown in FIG. 12 includes the use in the video display driver 1225 of a signal output 1227 to a personal computer 1270 or video game playing console 1280 such as a Play Station from SONY, or an X-Box from Microsoft. The video information is conveyed to the personal computer by transmission means 1290 such as a USB cable and network, an Ethernet cable and network, a "Firewire" IEEE 1394 standards cable and network, or by many other means well known to those skilled in the art.

[0086] Accordingly, it will be understood that the infrared toy scope may be utilized in a variety of games having various objectives, such as, locating targets, locating game players, and other similar or related activity. It will also be appreciated that the infrared toy scope may be entertaining to children on multiple levels. Children will have fun not only playing the aforesaid games, but also they will have the thrill of being able to see in dark or low lit conditions. Accordingly, the infrared toy scope is highly useful and entertaining.

What is claimed:

1. An infrared toy scope for converting infrared electromagnetic energy of an image to an image in the visible light portion of the electromagnetic spectrum comprising

an input focusing lens for focusing infrared electromagnetic energy of an image on an infrared sensor;

an infrared sensor having an infrared sensitive surface and being positioned so that at least a portion of the infrared electromagnetic energy of the image passing through the input focusing lens is incident to the infrared sensitive surface, the infrared sensor having an electrical output responsive to the infrared electromagnetic energy of the image incident to the infrared sensitive surface;

a plurality of analog to digital converters for receiving the electrical output of the infrared sensor and converting the electrical output to digital information;

a central processing unit coupled to the analog to digital converters for receiving the electrical output of digital information from the analog to digital converters, the central processing unit being capable of processing the digital information from the analog to digital converters and producing an electrical output of digital image data;

an image display having an image display surface, the image display being operably connected to the electrical output of digital image data from the central processing unit and the image display surface being responsive to said digital image data for creating an image in the visible light portion of the electromagnetic spectrum similar to the infrared electromagnetic energy incident to the infrared sensitive surface of the infrared sensor.

2. The apparatus of claim 1, including an output focusing lens positioned in front of the image display surface for focusing the image on the image display surface for a user.

3. The apparatus of claim 1, including an infrared filter proximate the input focusing lens for attenuating non-infrared electromagnetic energy and inhibiting non-infrared electromagnetic energy from striking the infrared sensitive surface of the infrared sensor.

4. The apparatus of claim 1, including an infrared illumination source for illuminating an area so as to produce reflected infrared electromagnetic energy for entry into the input focusing lens and wherein at least a portion of the reflected infrared electromagnetic energy is focused onto the infrared sensitive surface of the infrared sensor.

5. The apparatus of claim 2, including a translucent filter of a predetermined color located proximate the output focusing lens for permitting only visible light of the predetermined color to pass through the filter so that only visible light of the predetermined color will be seen by the user when the user looks at the image display surface of the image display.

6. The apparatus of claim 1, including media containing image averaging instructions operably connected to the central processing unit for enabling the central processing unit to aggregate over time the electrical output of the digital information from the analog to digital converters.

7. The apparatus of claim 4, wherein the central processing unit is operably connected to the infrared illumination source for controlling the period during which the infrared illumination source is operating.

8. The apparatus of claim 7, wherein the infrared illumination source and the central processing unit are synchronized so that the central processing unit processes the output

of digital information from the analog to digital converter only when the infrared illumination source is operating.

9. The apparatus of claim 1, including an alarm operably connected to the central processing unit, the alarm being activated in response to a change of output of the analog to digital converters above a predetermined level.

10. The apparatus of claim 1, including a sensitivity control operably connected to infrared sensor and electrical output of the infrared sensor for adjusting the sensitivity of the infrared sensor.

11. The apparatus of claim 1, including

a brightness control operably connected to the image display for controlling the brightness of the image on the image on the image display surface.

12. The apparatus of claim 12, including

a contrast control operably connected to the image display for controlling the contrast of the image on the image display surface.

13. The apparatus of claim 2, including a second output focusing lens position with respect to the first focusing lens so that the image on the image display surface is simultaneously viewable in each eye of the user.

14. A game comprising the steps of

illuminating a play area with infrared electromagnetic energy;

placing one or more play objects in the play area;

using the apparatus of claim 1 to locate the play objects.

15. The game of claim 14, including the step of

affixing an infrared beacon to one or more of the play objects.

16. The game of claim 15, including the step of

affixing to one or more of the play objects an infrared reflector.

17. The game of claim 14, including the step of

affixing to one or more of the play objects an infrared beacon.

18. The game of claim 14, wherein one or more of the play objects is a human being.

19. The game of claim 15, including the step of

intermittently transmitting infrared electromagnetic energy by one or more of the infrared beacons.

20. The game of claim 12, including the step of

illuminating a play area with infrared illumination from one or more supplemental infrared sources to provide additional infrared illumination to the play area.

* * * * *