



- (51) International Patent Classification:
G06F 13/16 (2006.01) C07H 21/04 (2006.01)
- (21) International Application Number:
PCT/US2017/052305
- (22) International Filing Date:
19 September 2017 (19.09.2017)
- (25) Filing Language: English
- (26) Publication Language: English
- (30) Priority Data:
62/397,855 21 September 2016 (21.09.2016) US
62/446,178 13 January 2017 (13.01.2017) US
62/517,671 09 June 2017 (09.06.2017) US
- (71) Applicant: TWIST BIOSCIENCE CORPORATION [US/US]; 455 Mission Bay Boulevard South, Suite 545, San Francisco, California 94158 (US).
- (72) Inventor: PECK, Bill James; 3086 Carleton Place, Santa Clara, California 95051 (US).
- (74) Agent: DUSABAN GONZALES, Stephanie; Wilson Sonsini Goodrich & Rosati, 650 Page Mill Road, Palo Alto, California 94304 (US).
- (81) Designated States (unless otherwise indicated, for every kind of national protection available): AE, AG, AL, AM, AO, AT, AU, AZ, BA, BB, BG, BH, BN, BR, BW, BY, BZ, CA, CH, CL, CN, CO, CR, CU, CZ, DE, DJ, DK, DM, DO, DZ, EC, EE, EG, ES, FI, GB, GD, GE, GH, GM, GT, HN, HR, HU, ID, IL, IN, IR, IS, JO, JP, KE, KG, KH, KN, KP, KR, KW, KZ, LA, LC, LK, LR, LS, LU, LY, MA, MD, ME, MG, MK, MN, MW, MX, MY, MZ, NA, NG, NI, NO, NZ, OM, PA, PE, PG, PH, PL, PT, QA, RO, RS, RU, RW, SA, SC, SD, SE, SG, SK, SL, SM, ST, SV, SY, TH, TJ, TM, TN, TR, TT, TZ, UA, UG, US, UZ, VC, VN, ZA, ZM, ZW.
- (84) Designated States (unless otherwise indicated, for every kind of regional protection available): ARIPO (BW, GH, GM, KE, LR, LS, MW, MZ, NA, RW, SD, SL, ST, SZ, TZ, UG, ZM, ZW), Eurasian (AM, AZ, BY, KG, KZ, RU, TJ, TM), European (AL, AT, BE, BG, CH, CY, CZ, DE, DK, EE, ES, FI, FR, GB, GR, HR, HU, IE, IS, IT, LT, LU, LV,

(54) Title: NUCLEIC ACID BASED DATA STORAGE

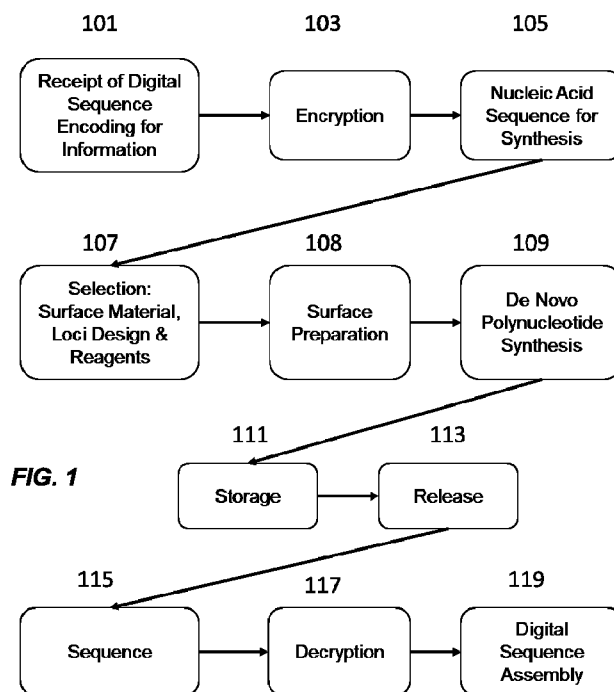

FIG. 1

(57) Abstract: Provided herein are compositions, devices, systems and methods for the generation and use of biomolecule-based information for storage. Additionally, devices described herein for de novo synthesis of nucleic acids encoding information related to the original source information may be rigid or flexible material. Further described herein are highly efficient methods for long term data storage with 100% accuracy in the retention of information. Also provided herein are methods and systems for efficient transfer of preselected polynucleotides from a storage structure for reading stored information.



MC, MK, MT, NL, NO, PL, PT, RO, RS, SE, SI, SK, SM,
TR), OAPI (BF, BJ, CF, CG, CI, CM, GA, GN, GQ, GW,
KM, ML, MR, NE, SN, TD, TG).

Declarations under Rule 4.17:

- *as to applicant's entitlement to apply for and be granted a patent (Rule 4.17(ii))*
- *as to the applicant's entitlement to claim the priority of the earlier application (Rule 4.17(iii))*

Published:

- *without international search report and to be republished upon receipt of that report (Rule 48.2(g))*
- *with sequence listing part of description (Rule 5.2(a))*

NUCLEIC ACID BASED DATA STORAGE

CROSS-REFERENCE

[0001] This application claims the benefit of U.S. Provisional Application No. 62/517,671 filed June 9, 2017; U.S. Provisional Application No. 62/446,178 filed January 13, 2017; and U.S. Provisional Application No. 62/397,855 filed September 21, 2016, each of which is incorporated herein by reference in its entirety.

SEQUENCE LISTING

[0002] The instant application contains a Sequence Listing which has been submitted electronically in ASCII format and is hereby incorporated by reference in its entirety. Said ASCII copy, created on September 18, 2017, is named 44854_728_601_SL.txt and is 1,612 bytes in size.

BACKGROUND

[0003] Biomolecule based information storage systems, *e.g.*, DNA-based, have a large storage capacity and stability over time. However, there is a need for scalable, automated, highly accurate and highly efficient systems for generating biomolecules for information storage.

BRIEF SUMMARY

[0004] Provided herein are methods for storing and accessing information, the method comprising: (a) converting at least one item of information in a form of at least one digital sequence to at least one nucleic acid sequence; (b) providing a structure comprising a surface; (c) synthesizing a plurality of polynucleotides having predetermined sequences collectively encoding for the at least one nucleic acid sequence, wherein each polynucleotide extends from the surface; (d) storing the plurality of polynucleotides; and (e) selectively transferring the plurality of polynucleotides to a receiving unit, wherein selectively transferring comprises application of a force, wherein the force is laminar pressure, capillary pressure, slip flow pressure, magnetic force, electrostatic force, peristaltic force, sound waves, vibrational force, centripetal force, centrifugal force, or any combination thereof, and wherein the plurality of polynucleotides collectively encodes for a single nucleic acid sequence of the at least one nucleic acid sequence. Further provided herein are methods, wherein the application of force comprises a conducting member, and an applied voltage potential between the structure and the conducting member. Further provided herein are methods, wherein the application of force comprises contacting the surface of the structure with a rigid or flexible slip. Further provided herein are methods, wherein the application of force comprises a pressure release or pressure nozzle. Further provided herein are methods further

comprising using the pressure nozzle during step (c). Further provided herein are methods further comprising flooding the polynucleotides through the pressure nozzle. Further provided herein are methods further comprising depositing nucleotides through the pressure nozzle. Further provided herein are methods further comprising: sequencing the plurality of polynucleotides; and assembling the at least one digital sequence. Further provided herein are methods, wherein the at least one digital sequence assembled is 100% accurate compared to an initial at least one digital sequence.

[0005] Provided herein are methods for storing information, the method comprising: (a) converting at least one item of information in a form of at least one digital sequence to at least one nucleic acid sequence; (b) synthesizing a plurality of polynucleotides having predetermined sequences collectively encoding for the at least one nucleic acid sequence, wherein each polynucleotide comprises: (i) a plurality of coding regions, wherein each coding region is identical; and (ii) at least one non-coding region, wherein the at least one non-coding region comprises a cleavage region; and (c) storing the plurality of polynucleotides. Further provided herein are methods, wherein the cleavage region comprises a restriction enzyme recognition site. Further provided herein are methods, wherein the cleavage region comprises a light sensitive nucleobase. Further provided herein are methods further comprising application of a restriction enzyme, electromagnetic radiation, or a gaseous reagent to cleave at the cleavage region, thereby removing at least one of the plurality of coding regions. Further provided herein are methods, wherein each coding region comprises 25 to 500 bases in length. Further provided herein are methods, wherein each coding region comprises 100 to 2000 bases in length. Further provided herein are methods, wherein each non-coding region comprises 1 to 100 bases in length. Further provided herein are methods, wherein each non-coding region comprises at most 200 bases. Further provided herein are methods, wherein the plurality of polynucleotides comprises at least 100,000 polynucleotides. Further provided herein are methods, wherein the plurality of polynucleotides comprises at least 10 billion polynucleotides. Further provided herein are methods, wherein greater than 90% of the polynucleotides encode for a sequence that does not differ from the predetermined sequence. Further provided herein are methods, wherein the at least one item of information is text information, audio information or visual information. Further provided herein are methods, wherein a first non-coding region within each polynucleotide has a different sequence than a second non-coding region within each polynucleotide. Further provided herein are methods, wherein each non-coding region within each polynucleotide has a different sequence. Further provided herein are methods, wherein a first cleavage region within each polynucleotide has a different sequence than a second cleavage region within each polynucleotide. Further provided herein are methods, wherein each cleavage region within each polynucleotide has a different sequence. Further provided herein

are methods, wherein a number of cleavage regions within each polynucleotide is at least 1, 2, 3, 4, or 5. Further provided herein are methods, wherein a sequence for the number of cleavage regions is different. Further provided herein are methods, wherein each polynucleotide comprises a tether region.

[0006] Provided herein are methods for encrypting information, the method comprising: (a) converting at least one item of information in a form of at least one digital sequence to at least one nucleic acid sequence; (b) associating each of the at least one nucleic acid sequence with one of a plurality of non-identical markings; (c) providing a structure having a surface, wherein the surface comprises the plurality of non-identical markings; (d) synthesizing a plurality of polynucleotides having predetermined sequences collectively encoding for the at least one nucleic acid sequence, wherein the plurality of polynucleotides comprises at least 100,000 polynucleotides, and wherein each polynucleotide extends from the surface in a discrete region demarcated by one of the non-identical markings; and (e) storing the plurality of polynucleotides. Further provided herein are methods, wherein the plurality of polynucleotides comprises at least 1,000,000 polynucleotides. Further provided herein are methods, wherein greater than 90% of the polynucleotides encode for a sequence that does not differ from the predetermined sequence. Further provided herein are methods, wherein the at least one item of information is text information, audio information or visual information. Further provided herein are methods, wherein a subset of the polynucleotides discretely demarcated by one of the non-identical markings comprise a same sequence. Further provided herein are methods further comprising selecting a subset of polynucleotides discretely demarcated by one of the non-identical markings, releasing the subset of polynucleotides, sequencing the plurality of polynucleotides, decrypting the plurality of polynucleotides, and assembling the at least one digital sequence. Further provided herein are methods further comprising selecting a subset of polynucleotides discretely demarcated by one of the non-identical markings, amplifying the subset of polynucleotides, sequencing the subset of polynucleotides, decrypting the plurality of polynucleotides, and assembling the at least one digital sequence. Further provided herein are methods, wherein the at least one digital sequence assembled is 100% accurate compared to an initial at least one digital sequence. Further provided herein are methods, wherein the at least one digital sequence comprises an amount of digital information of at least 1 gigabyte. Further provided herein are methods, wherein the at least one digital sequence comprises an amount of digital information of at least 1 terabyte. Further provided herein are methods, wherein the at least one digital sequence comprises an amount of digital information of at least 1 petabyte.

[0007] Provided herein are methods for collection of information, the method comprising: (a) providing a structure comprising a surface, wherein the structure comprises: a first plurality of polynucleotides having predetermined sequences collectively encoding for at least one nucleic acid sequence; and a second plurality of polynucleotides having predetermined sequences collectively encoding for the at least one nucleic acid sequence, wherein the first plurality of polynucleotides and the second plurality of polynucleotides both extend from the surface and both encode for the same at least one nucleic acid sequence; (b) selectively separating a region of the structure comprising the first plurality of polynucleotides and removing the first plurality of polynucleotides from the surface; and (c) sequencing and decrypting the at least one nucleic acid sequence to form at least one digital sequence encoding for an item of information. Further provided herein are methods, wherein a region of the structure comprising the first plurality of polynucleotides comprises a cluster of channels or wells. Further provided herein are methods, wherein the structure is a rigid structure. Further provided herein are methods, wherein the structure is a flexible structure. Further provided herein are methods, wherein a region of the structure comprising only a remaining portion of the structure lacking the first plurality of polynucleotides is spliced back together. Further provided herein are methods, wherein selectively removing comprises application of force to a region of the structure comprising the first plurality of polynucleotides. Further provided herein are methods, wherein the application of force is laminar pressure, capillary pressure, slip flow pressure, magnetic force, electrostatic force, peristaltic force, sound waves, vibrational force, centripetal force, centrifugal force, or any combination thereof. Further provided herein are methods, wherein the application of force comprises a conducting member, and an applied voltage potential between the structure and the conducting member. Further provided herein are methods, wherein the application of force comprises contacting the surface of the structure with a rigid or flexible slip. Further provided herein are methods, wherein the application of force comprises a pressure release or pressure nozzle. Further provided herein are methods, wherein each polynucleotide of the first plurality of nucleotides comprises at most 500 bases in length. Further provided herein are methods, wherein each polynucleotide of the first plurality of nucleotides comprises at most 200 bases in length. Further provided herein are methods, wherein each polynucleotide of the second plurality of nucleotides comprises at most 500 bases in length. Further provided herein are methods, wherein each polynucleotide of the second plurality of nucleotides comprises at most 200 bases in length. Further provided herein are methods, wherein an amount of the item of information is at least one gigabyte. Further provided herein are methods, wherein an amount of the item of information is at least one terabyte. Further provided herein are methods, wherein an amount of the item of information is at least one petabyte.

[0008] Provided herein are nucleic acid libraries, comprising a plurality of polynucleotides, wherein each of the polynucleotides comprises: (i) a plurality of coding regions, wherein each coding region is identical; and (ii) at least one non-coding region, wherein the at least one non-coding region comprises a cleavage region; and wherein when the plurality of polynucleotides are sequenced, decrypted, and assembled to form a digital sequence, the digital sequence has greater than 90% accuracy compared to a preselected digital sequence. Further provided herein are nucleic acid libraries, wherein the cleavage region comprises a restriction enzyme recognition site. Further provided herein are nucleic acid libraries, wherein the cleavage region comprises a light sensitive nucleobase. Further provided herein are nucleic acid libraries, further comprising application of a restriction enzyme, electromagnetic radiation, or a gaseous reagent to cleave at the cleavage region, thereby removing at least one of the plurality of coding regions. Further provided herein are nucleic acid libraries, wherein each coding region comprises 25 to 500 bases in length. Further provided herein are nucleic acid libraries, wherein each coding region comprises 100 to 2000 bases in length. Further provided herein are nucleic acid libraries, wherein each non-coding region comprises 1 to 100 bases in length. Further provided herein are nucleic acid libraries, wherein each non-coding region comprises at most 200 bases. Further provided herein are nucleic acid libraries, wherein the plurality of polynucleotides comprises at least 100,000 polynucleotides. Further provided herein are nucleic acid libraries, wherein the plurality of polynucleotides comprises at least 10 billion polynucleotides. Further provided herein are nucleic acid libraries, wherein greater than 90% of the polynucleotides encode for a sequence that does not differ from a predetermined sequence. Further provided herein are nucleic acid libraries, wherein a first non-coding region within each polynucleotide has a different sequence than a second non-coding region within each polynucleotide. Further provided herein are nucleic acid libraries, wherein each non-coding region within each polynucleotide has a different sequence. Further provided herein are nucleic acid libraries, wherein a first cleavage region within each polynucleotide has a different sequence than a second cleavage region within each polynucleotide. Further provided herein are nucleic acid libraries, wherein each cleavage region within each polynucleotide has a different sequence. Further provided herein are nucleic acid libraries, wherein a number of cleavage regions within each polynucleotide is at least 1, 2, 3, 4, or 5. Further provided herein are nucleic acid libraries, wherein a sequence for the number of cleavage regions is different.

[0009] Provided herein are devices for storing information, the device comprising: (a) a structure having a surface; and (b) a plurality of discrete regions on the surface for synthesizing a plurality of polynucleotides having predetermined sequences collectively encoding for at least one nucleic acid sequence, wherein each polynucleotide comprises: (i) a plurality of coding regions, wherein each

coding region is identical; and (ii) at least one non-coding region, wherein the at least one non-coding region comprises a cleavage region; and wherein the at least one nucleic acid sequence encodes for at least one item of information.

[0010] Provided herein are devices for encrypting information, the device comprising: (a) a structure having a surface, wherein the surface comprises a plurality of non-identical markings; and (b) a plurality of discrete regions on the surface for synthesizing a plurality of polynucleotides having predetermined sequences collectively encoding for at least one nucleic acid sequence, wherein the plurality of polynucleotides comprises at least 100,000 polynucleotides, and wherein each polynucleotide extends from the surface in a discrete region demarcated by one of the non-identical markings; and wherein the at least one nucleic acid sequence encodes for at least one item of information.

[0011] Provided herein are methods for storing information, the method comprising: (a) converting at least one item of information in the form of at least one digital sequence to at least one nucleic acid sequence; (b) synthesizing a plurality of polynucleotides having predetermined sequences collectively encoding for the at least one nucleic acid sequence, wherein each polynucleotide comprises: (i) at least one coding sequence up to about 500 bases in length; and (ii) at least one bar code sequence, wherein the bar code sequence comprises sequence associated with the identity of the coding sequence; and (c) storing the plurality of polynucleotides. Further provided herein are methods, wherein each polynucleotide comprises at least one coding sequence up to about 300 bases in length. Further provided herein are methods, wherein the plurality of polynucleotides comprises at least about 100,000 polynucleotides. Further provided herein are methods, wherein the plurality of polynucleotides comprises at least about 10 billion polynucleotides. Further provided herein are methods, wherein greater than 90% of the polynucleotides encode for a sequence that does not differ from the predetermined sequence. Further provided herein are methods, wherein the at least one item of information is text information, audio information or visual information.

INCORPORATION BY REFERENCE

[0012] All publications, patents, and patent applications mentioned in this specification are herein incorporated by reference to the same extent as if each individual publication, patent, or patent application was specifically and individually indicated to be incorporated by reference.

BRIEF DESCRIPTION OF THE DRAWINGS

[0013] The novel features of the invention are set forth with particularity in the appended claims. A better understanding of the features and advantages of the present invention will be obtained by

reference to the following detailed description that sets forth illustrative embodiments, in which the principles of the invention are utilized, and the accompanying drawings of which:

[0014] **Figure 1** illustrates an exemplary workflow for nucleic acid-based data storage.

[0015] **Figures 2A-2C** depict various polynucleotide sequence design schemes.

[0016] **Figures 3A-3D** depict various polynucleotide sequence design schemes.

[0017] **Figures 4A-4B** depict a barcode design scheme.

[0018] **Figure 5** illustrates a plate configured for polynucleotide synthesis comprising 24 regions, or sub-fields, each having an array of 256 clusters.

[0019] **Figure 6** illustrates a closer view of the sub-field in **FIG. 5** having 16 x16 of clusters, each cluster having 121 individual loci.

[0020] **Figure 7** illustrates a detailed view of the cluster in **FIG. 5**, where the cluster has 121 loci.

[0021] **Figure 8A** illustrates a front view of a plate with a plurality of channels.

[0022] **Figure 8B** illustrates a sectional view of plate with a plurality of channels.

[0023] **Figures 9A-9B** depict a continuous loop and reel-to-reel arrangements for flexible structures.

[0024] **Figures 9C-9D** depict schemas for release and extraction of synthesized polynucleotides.

[0025] **Figures 10A-10C** depict a zoom in of a flexible structure, having spots, channels, or wells, respectively.

[0026] **Figure 11A** illustrates a zoom in of loci on a structure described herein.

[0027] **Figures 11B-11C** illustrate markings on structures described herein.

[0028] **Figure 12** illustrates a polynucleotide synthesis material deposition device.

[0029] **Figure 13** illustrates a polynucleotide synthesis workflow.

[0030] **Figures 14A-14B** illustrate a method for electrostatic deposition of a polynucleotide into a plurality of channels.

[0031] **Figures 15A-15B** illustrate an exemplary method for electrostatic transfer of a polynucleotide from a plurality of channels.

[0032] **Figures 16A-16B** illustrate a method for transfer of a polynucleotide from a plurality of channels, through a slip mechanism.

[0033] **Figures 17A-17B** illustrate a method for transfer of a polynucleotide from a plurality of channels, through a pressure release mechanism.

[0034] **Figure 18** illustrates a method for transfer of a polynucleotide from a plurality of channels in a flexible structure, through a nozzle mechanism.

[0035] **Figures 19A-19B** illustrate a method for capture of a polynucleotide from a plurality of channels, through a pin.

[0036] **Figures 20A-20B** illustrate a method for electrostatic capture of a polynucleotide from a plurality of channels.

[0037] **Figure 21** illustrates a method for electrostatic containment of a polynucleotide from a plurality of channels into a receiving unit.

[0038] **Figure 22** illustrates a method for electrostatic containment of a polynucleotide from a plurality of channels into a receiving unit.

[0039] **Figure 23** illustrates an example of a computer system.

[0040] **Figure 24** is a block diagram illustrating architecture of a computer system.

[0041] **Figure 25** is a diagram demonstrating a network configured to incorporate a plurality of computer systems, a plurality of cell phones and personal data assistants, and Network Attached Storage (NAS).

[0042] **Figure 26** is a block diagram of a multiprocessor computer system using a shared virtual address memory space.

DETAILED DESCRIPTION OF THE INVENTION

[0043] There is a need for larger capacity storage systems as the amount of information generated and stored is increasing exponentially. Traditional storage media have a limited capacity and require specialized technology that changes with time, requiring constant transfer of data to new media, often at a great expense. A biomolecule such as a DNA molecule provides a suitable host for information storage in-part due to its stability over time and capacity for four bit information coding, as opposed to traditional binary information coding. Thus, large amounts of data are encoded in the DNA in a relatively smaller amount of physical space than used by commercially available information storage devices. Provided herein are methods to increase DNA synthesis throughput through increased sequence density and decreased turn-around time.

[0044] Definitions

[0045] Unless defined otherwise, all technical and scientific terms used herein have the same meaning as is commonly understood by one of ordinary skill in the art to which these inventions belong.

[0046] Throughout this disclosure, numerical features are presented in a range format. It should be understood that the description in range format is merely for convenience and brevity and should not be construed as an inflexible limitation on the scope of any embodiments. Accordingly, the description of a range should be considered to have specifically disclosed all the possible subranges

as well as individual numerical values within that range to the tenth of the unit of the lower limit unless the context clearly dictates otherwise. For example, description of a range such as from 1 to 6 should be considered to have specifically disclosed subranges such as from 1 to 3, from 1 to 4, from 1 to 5, from 2 to 4, from 2 to 6, from 3 to 6 etc., as well as individual values within that range, for example, 1.1, 2, 2.3, 5, and 5.9. This applies regardless of the breadth of the range. The upper and lower limits of these intervening ranges may independently be included in the smaller ranges, and are also encompassed within the invention, subject to any specifically excluded limit in the stated range. Where the stated range includes one or both of the limits, ranges excluding either or both of those included limits are also included in the invention, unless the context clearly dictates otherwise.

[0047] The terminology used herein is for the purpose of describing particular embodiments only and is not intended to be limiting of any embodiment. As used herein, the singular forms “a,” “an” and “the” are intended to include the plural forms as well, unless the context clearly indicates otherwise. It will be further understood that the terms “comprises” and/or “comprising,” when used in this specification, specify the presence of stated features, integers, steps, operations, elements, and/or components, but do not preclude the presence or addition of one or more other features, integers, steps, operations, elements, components, and/or groups thereof. As used herein, the term “and/or” includes any and all combinations of one or more of the associated listed items.

[0048] Unless specifically stated or obvious from context, as used herein, the term “about” in reference to a number or range of numbers is understood to mean the stated number and numbers +/- 10% thereof, or 10% below the lower listed limit and 10% above the higher listed limit for the values listed for a range.

[0049] As used herein, the terms “preselected sequence”, “predefined sequence” or “predetermined sequence” are used interchangeably. The terms mean that the sequence of the polymer is known and chosen before synthesis or assembly of the polymer. In particular, various aspects of the invention are described herein primarily with regard to the preparation of nucleic acids molecules, the sequence of the oligonucleotide or polynucleotide being known and chosen before the synthesis or assembly of the nucleic acid molecules.

[0050] Provided herein are methods and compositions for production of synthetic (i.e. de novo synthesized or chemically synthesized) polynucleotides. Polynucleotides may also be referred to as oligonucleotides or oligos. Polynucleotide sequences described herein may be, unless stated otherwise, comprise DNA or RNA.

[0051] Nucleic Acid Based Information Storage

[0052] Provided herein are devices, compositions, systems and methods for nucleic acid-based information (data) storage. An exemplary workflow is provided in **FIG. 1**. In a first step, a digital sequence encoding an item of information (i.e., digital information in a binary code for processing by a computer) is received **101**. An encryption **103** scheme is applied to convert the digital sequence from a binary code to a nucleic acid sequence **105**. A surface material for nucleic acid extension, a design for loci for nucleic acid extension (aka, arrangement spots), and reagents for nucleic acid synthesis are selected **107**. The surface of a structure is prepared for nucleic acid synthesis **108**. De novo polynucleotide synthesis is performed **109**. The synthesized polynucleotides are stored **111** and available for subsequent release **113**, in whole or in part. Once released, the polynucleotides, in whole or in part, are sequenced **115**, subject to decryption **117** to convert nucleic sequence back to digital sequence. The digital sequence is then assembled **119** to obtain an alignment encoding for the original item of information.

[0053] Items of Information

[0054] Optionally, an early step of a DNA data storage process disclosed herein includes obtaining or receiving one or more items of information in the form of an initial code. Items of information include, without limitation, text, audio and visual information. Exemplary sources for items of information include, without limitation, books, periodicals, electronic databases, medical records, letters, forms, voice recordings, animal recordings, biological profiles, broadcasts, films, short videos, emails, bookkeeping phone logs, internet activity logs, drawings, paintings, prints, photographs, pixelated graphics, and software code. Exemplary biological profile sources for items of information include, without limitation, gene libraries, genomes, gene expression data, and protein activity data. Exemplary formats for items of information include, without limitation, .txt, .PDF, .doc, .docx, .ppt, .pptx, .xls, .xlsx, .rtf, .jpg, .gif, .psd, .bmp, .tiff, .png, and .mpeg. The amount of individual file sizes encoding for an item of information, or a plurality of files encoding for items of information, in digital format include, without limitation, up to 1024 bytes (equal to 1 KB), 1024 KB (equal to 1MB), 1024 MB (equal to 1 GB), 1024 GB (equal to 1TB), 1024 TB (equal to 1PB), 1 exabyte, 1 zettabyte, 1 yottabyte, 1 xenottabyte or more. In some instances, an amount of digital information is at least 1 gigabyte (GB). In some instances, the amount of digital information is at least 1, 2, 3, 4, 5, 6, 7, 8, 9, 10, 20, 50, 100, 200, 300, 400, 500, 600, 700, 800, 900, 1000 or more than 1000 gigabytes. In some instances, the amount of digital information is at least 1 terabyte (TB). In some instances, the amount of digital information is at least 1, 2, 3, 4, 5, 6, 7, 8, 9, 10, 20, 50, 100, 200, 300, 400, 500, 600, 700, 800, 900, 1000 or more than 1000 terabytes. In some instances, the amount of digital information is at least 1 petabyte (PB). In some instances,

the amount of digital information is at least 1, 2, 3, 4, 5, 6, 7, 8, 9, 10, 20, 50, 100, 200, 300, 400, 500, 600, 700, 800, 900, 1000 or more than 1000 petabytes.

[0055] Encryption

[0056] Binary code conversion

[0057] Generally, the initial code is digital information, typically in the form of binary code employed by a computer. General purpose computers are electronic devices reading “on” or “off” states, represented by the numbers “0” and “1”. This binary code is application for computers to read multiple types of items of information. In binary arithmetic, the number two is written as the number 10. For example, “10” indicates “one time the number, two and no more”. The number “3,” is written as “11” to mean “one times two and one more.” The number “4” is written as “100,” the number “5” as “101,” “six” as “110,” etc. An example of American Standard Code II (ASCII) for binary code is provided for the alphabet in lower and upper case in **Table 1**.

Table 1.

Letter	ASCII Code	Binary	Letter	ASCII Code	Binary	No.	ASCII Code	Binary
a	97	1100001	A	65	1000001	0	chr(0)	00000000
b	98	1100010	B	66	1000010	1	chr(1)	00000001
c	99	1100011	C	67	1000011	2	chr(2)	00000010
d	100	1100100	D	68	1000100	3	chr(3)	00000011
e	101	1100101	E	69	1000101	4	chr(4)	00000100
f	102	1100110	F	70	1000110	5	chr(5)	00000101
g	103	1100111	G	71	1000111	6	chr(6)	00000110
h	104	1101000	H	72	1001000	7	chr(7)	00000111
i	105	1101001	I	73	1001001	8	chr(8)	00001000
j	106	1101010	J	74	1001010	9	chr(9)	00001001
k	107	1101011	K	75	1001011	10	chr(10)	00001010
l	108	1101100	L	76	1001100	11	chr(11)	00001011
m	109	1101101	M	77	1001101	12	chr(12)	00001100
n	110	1101110	N	78	1001110	13	chr(13)	00001101
o	111	1101111	O	79	1001111	14	chr(14)	00001110
p	112	1110000	P	80	1010000	15	chr(15)	00001111
q	113	1110001	Q	81	1010001	16	chr(16)	00010000
r	114	1110010	R	82	1010010	17	chr(17)	00010001
s	115	1110011	S	83	1010011	18	chr(18)	00010010
t	116	1110100	T	84	1010100	19	chr(19)	00010011
u	117	1110101	U	85	1010101	20	chr(20)	00010100
v	118	1110110	V	86	1010110	21	chr(21)	00010101
w	119	1110111	W	87	1010111	22	chr(22)	00010110

x	120	1111000		X	88	1011000		23	chr(23)	00010111
y	121	1111001		Y	89	1011001		24	chr(24)	00011000
z	122	1111010		Z	90	1011010		25	chr(25)	00011001
								26	chr(26)	00011010
								27	chr(27)	00011011
								28	chr(28)	00011100
								29	chr(29)	00011101
								30	chr(30)	00011110

[0058] Provided herein are methods for converting information in the form of a first code, e.g., a binary sequence to a nucleic acid sequence. The process may involve direct conversion from a base 2 code (i.e., binary) to a base code that is higher. Exemplary base codes include 2, 3, 4, 5, 6, 7, 8, 9, 10 or more. **Table 2** illustrates an exemplary alignment between various base numbering schemes. A computer receiving machine instructions for conversion, can automatically convert sequence information from one code to another.

Table 2.

Decimal	0	1	2	3	4	5	6	7	8	9
Quaternary	0	1	2	3	10	11	12	13	20	21
Octal	0	1	2	3	4	5	6	7	10	11
Ternary	0	1	2	10	11	12	20	21	22	100
Binary	0	1	10	11	100	101	110	111	1000	1001

[0059] Canonical DNA is a base 4 coding system, having four different nucleobases available: A, T, C or G (adenine, thymine, cytosine, and guanine). Thus, these 4 bases allow for a base 3 (using less than all), or a 4 base coding scheme. In addition, use of uracil (U), which is found in RNA, provides a fifth base and allows for a base 5 coding scheme. In addition, modified nucleobase may be used for a nucleic acid base coding greater than 4. Nucleobases that are not canonical DNA nucleobases or modified nucleobases include, without limitation, uracil, 3-meA (3-methyladenine), hypoxanthine, 8-oxoG (7,8-dihydro-8-oxoguanine), FapyG, FapyA, Tg (thymine glycol), hoU (hydroxyuracil), hmU (hydroxymethyluracil), fU (formyluracil), hoC (hydroxycytosine), fC (formylcytosine), 5-meC (5-methylcytosine), 6-meG (O6-methylguanine), 7-meG (N7-methylguanine), εC (ethenocytosine), 5-caC (5-carboxylcytosine), 2-hA, εA (ethenoadenine), 5-fU (5-fluorouracil), 3-meG (3-methylguanine), and isodialuric acid. Further provided herein are coding schemes where machine instructions provide for conversion of digital information in the form of a binary sequence into an intermediate code prior to ultimately being converted to the final nucleic acid sequence.

[0060] In some instances, to store data in a sequence of DNA, the information is converted from the 1s and 0s of binary code into the code of A, T, G, and C bases of DNA. In some instances, items of information are first encoded in a digital information form. In some cases, the binary code of digital information is converted into a biomolecule-based (e.g., DNA-based) code while preserved the information that the code represents. This converted code (digital binary code to a biomolecule code) is referred to herein as resulting in a “predetermined” sequence with respect to the deposit of a biomolecule disclosed herein on a surface disclosed herein. The predetermined sequence may encode sequence for a plurality of polynucleotides.

[0061] Nucleic Acid Sequence

[0062] Provided herein are methods for designing a sequence for a polynucleotide described herein such that the nucleic acid sequence encodes for at least part of an item of information. In some instances, each polynucleotide sequence has design features to facilitate with sequence alignment during subsequent assembly steps and also to provide a means for error correction. In some arrangements, polynucleotide sequences are designed such that overlap exists between each polynucleotide sequence with another in the population. In some instances, each polynucleotide sequence overlaps with a portion of just one other polynucleotide sequence, **FIG. 2A**. In an alternative arrangement, each polynucleotide sequence region overlaps with two sequences such that 2 copies are generated for each sequence within a single polynucleotide, **FIG. 2B**. In yet another arrangement, each polynucleotide sequence region overlaps with more than two sequences such that 3 copies are generated for each sequence within a single polynucleotide, **FIG. 2C**. Sequences for polynucleotides described herein may encode for 10-2000, 10-500, 30-300, 50-250, or 75-200 bases in length. In some instances, each of the polynucleotides sequence is at least 10, 15, 20, 25, 30, 50, 100, 150, 200, 500 or more bases in length.

[0063] In some arrangements, each polynucleotide sequence described herein is designed to comprise a plurality of coding regions and a plurality of non-coding regions, **FIG. 3A**. In such an arrangement, each coding region (e.g., **301, 303, 305**) encodes for at least a portion of an item of information. Optionally, each coding region in the same polynucleotide encodes for sequence from the same item of information, and an overlapping scheme is optionally employed as described herein, **FIG. 3B**. In further instances, each coding region in the same polynucleotide encodes for the same sequence, **FIGS. 3C-3D**. Sequences for polynucleotides described herein may encode for at least 1, 2, 3, 4, 5, 6, 7, 8, 9, 10, 11, 12, 13, 14, 15, 16, 17, 18, 19, 20 or more coding regions. Sequences for polynucleotides described herein may encode for at least 1, 2, 3, 4, 5, 6, 7, 8, 9, 10, 11, 12, 13, 14, 15, 16, 17, 18, 19, 20 or more of the same coding region. In some instances, each of the multiple coding regions is 10-1000, 20-500, 30-300, 50-250, or 75-200 bases in length. In some

instances, each of the multiple coding regions is 25-500, 25-200, 50-300, 50-200, 75-150, 10-2000, 20-1000, or 25-500 bases in length. In some instances, each of the multiple coding regions is at least 10, 15, 20, 25, 30, 50, 100, 150, 200 or more bases in length. In some instances, each of the multiple coding regions is at least 10, 50, 100, 150, 200, 250, 300, 350, 400, 450, 500, 550, 600, 650, 700, 750, 800, 900, 1000, or more than 1000 bases. In some instances, each of the multiple coding regions is at most 10, 50, 100, 150, 200, 250, 300, 350, 400, 450, 500, 550, 600, 650, 700, 750, 800, 900, 1000, or more than 1000 bases. In some instances, each polynucleotide comprises a tether region **311** linking the molecule to the surface **302** of a structure.

[0064] In arrangements where multiple coding sequences are present in the same polynucleotide, a cleavage region **307** is optionally present in between each coding region. The cleavage region **307** may be present at the junction between each coding region, or may be present within an adaptor region having a string of sequence between each coding region. A cleavage region **307** may encode for a sequence feature, once synthesized, which will break from the strand subsequent to application of a cleavage signal. The cleavage region **307** may encode for a restriction enzyme recognition site, a modified nucleic acid that is light sensitive and will break under application of electromagnetic radiation (e.g., oligodeoxynucleotide heteropolymers carrying base-sensitive S-pivaloylthioethyl (t-Bu-SATE) phosphotriester linkages sensitive to light wavelengths of >300 nm), or modified nucleic acid that is sensitive to application of a certain chemical, e.g., Thymidine-succinyl hexamide CED phosphoramidite (CLP-2244 from ChemGenes) which breaks subsequent to application of ammonia gas. Because the design of a sequence to have a particular cleavage scheme may not be readily apparent from sequencing synthesized polynucleotides, the cleavage scheme provides a means for adding a level of security to sequence encoded by the synthesized nucleic acid library. Sequences for polynucleotides described herein may encode for at least 1, 2, 3, 4, 5, 6, 7, 8, 9, 10, 11, 12, 13, 14, 15, 16, 17, 18, 19, 20 or more cleavage regions. Sequences for polynucleotides described herein may encode for at least 1, 2, 3, 4, or 5 cleavage regions. In some instances, each of the cleavage region encodes for is 1-100, 1-50, 1-20, 1-10, 5-25, or 5-30 bases in length. In some instances, each of the cleavage region encodes for at least 1, 2, 3, 4, 5, 6, 7, 8, 9, 10, 11, 12, 13, 14, 15, 16, 17, 18, 19, 20, 25, 30, 40, 50, 100 or more bases. In some arrangements, for each polynucleotide, each coding region is identical and each cleavage region between each coding region is different. For example, a first cleavage region **307** is different from a second cleavage region **309**. In some arrangements, the cleavage region **307** closest to the surface **302** is identical to the next distal cleavage region **307**. In some instances, each coding region is different from each of the other coding region. For example, a first cleavage region **307** is different from a second cleavage region **309** and from a third cleavage region **308**.

[0065] Provided herein are polynucleotide sequences designed to comprise a plurality of coding regions and a plurality of non-coding regions, wherein the non-coding regions vary in length and number. For example, sequences for polynucleotides described herein may comprise at least 1, 2, 3, 4, 5, 6, 7, 8, 9, 10, 11, 12, 13, 14, 15, 16, 17, 18, 19, 20 or more non-coding regions. Sequences for polynucleotides described herein may comprise at least 1, 2, 3, 4, 5, 6, 7, 8, 9, 10, 11, 12, 13, 14, 15, 16, 17, 18, 19, 20 or more of the same non-coding region. In some instances, each of the multiple non-coding regions is 10-1000, 20-500, 30-300, 50-250, or 75-200 bases in length. In some instances, each of the multiple non-coding regions is at least 1-100, 5-90, 10-80, 15-70, 20-60, 25-50, or 30-40 bases in length. In some instances, each of the multiple non-coding regions is at least 10, 15, 20, 25, 30, 50, 100, 150, 200 or more bases in length. In some instances, each of the multiple non-coding regions is at most 10, 15, 20, 25, 30, 50, 100, 150, 200, or more bases in length. In some instances, the non-coding regions are barcodes.

[0066] Barcodes are typically known nucleic acid sequences that allow some feature of a polynucleotide with which the barcode is associated to be identified. **FIGS. 4A-4B** provide an illustrative barcode arrangement. In **FIG. 4A**, each coding region for a first polynucleotide **301**, a second polynucleotide **303**, and a third polynucleotide **305**, has the following features (from surface **302** outward): a tether region **302**, a cleavage region **307**, an first primer binding region **401**, a barcode region **403**, a coding region **301**, **303**, **305**, and a second primer binding region **404**. The polynucleotides may be amplified with the use of primers that recognize the first and/or second primer binding regions. Amplification may occur to polynucleotides attached to the surface or released from the surface (i.e., via cleavage at the cleavage region **307**). After sequencing, the barcode region **403**, provides an indicator for identifying a characteristic associated with the coding region. In some embodiments, a barcode comprises a nucleic acid sequence that when joined to a target polynucleotide serves as an identifier of the sample from which the target polynucleotide was derived. Barcodes can be designed at suitable lengths to allow sufficient degree of identification, e.g., at least 3, 4, 5, 6, 7, 8, 9, 10, 11, 12, 13, 14, 15, 16, 17, 18, 19, 20, 21, 22, 23, 24, 25, 26, 27, 28, 29, 30, 31, 32, 33, 34, 35, 36, 37, 38, 39, 40, 41, 42, 43, 44, 45, 46, 47, 48, 49, 50, 51, 52, 53, 54, 55, or more bases in length. Multiple barcodes, such as 2, 3, 4, 5, 6, 7, 8, 9, 10, or more barcodes, may be used on the same molecule, optionally separated by non-barcode sequences. In some embodiments, barcodes are shorter than 10, 9, 8, 7, 6, 5, or 4 bases in length. In some embodiments, barcodes associated with some polynucleotides are of different length than barcodes associated with other polynucleotides. In general, barcodes are of sufficient length and comprise sequences that are sufficiently different to allow the identification of samples based on barcodes with which they are associated. In some arrangements, a barcode, and the sample source with

which it is associated, can be identified accurately after the mutation, insertion, or deletion of one or more bases in the barcode sequence, such as the mutation, insertion, or deletion of 1, 2, 3, 4, 5, 6, 7, 8, 9, 10, or more bases. In some embodiments, each barcode in a plurality of barcodes differ from every other barcode in the plurality at least three base positions, such as at least 3, 4, 5, 6, 7, 8, 9, 10, or more positions. Arrangements provided herein may include bar codes sequence that correspond the nucleic acid sequence to encode sequence for a particular region of a digital sequence. For example, a barcode sequence may indicate where in a large file a particular polynucleotide sequence encodes. In some instances, a barcode sequence may indicate which file a particular polynucleotide sequence is associated with. In some instances, a barcode sequence includes information associated with the conversion scheme for a particular sequence, providing an added layer of security.

[0067] Provided herein are polynucleotide sequence design schemes where each polynucleotide sequence acid in a population is designed to have at least one region in common amongst polynucleotide sequences in that population. For example, all polynucleotides in the same population may comprise one or more primer regions. The design of sequence-specific primer regions allows for the selection of polynucleotides to be amplified in selected batches from a large library of multiple polynucleotides. Each polynucleotide sequence may comprise at least 1, 2, 3, 4, 5, 6, 7, 8, 9, 10 or more primer binding sequences. A population of polynucleotide sequence may comprise at least 1, 2, 3, 4, 5, 6, 7, 8, 9, 10, 25, 50, 100, 200, 500, 1000, 5000, 10000, 50000, 100000 or more non-identical binding sequences. Primer binding sequences may comprise 5-100, 10-75, 7-60, 8-60, 10-50, or 10-40 bases in length.

[0068] Structures for polynucleotide synthesis

[0069] Provided herein are rigid or flexibles structures for polynucleotide synthesis. In the case of rigid structures, provided herein are devices having a structure (*e.g.*, a plate) for the generation of a library of polynucleotides. An exemplary structure **500** is illustrated in **FIG. 5**, wherein the structure **500** has about the same size dimensions as a standard 96 well plate: 140 mm by 90 mm. The structure **500** comprises clusters grouped in 24 regions or sub-fields **505**, each sub-field **505** comprising an array of 256 clusters **510**. An expanded view of an exemplary sub-field **505** is shown in **FIG. 6**. In the expanded view of four clusters (**FIG.6**), a single cluster **510**, has a Y axis cluster pitch (distance from center to center of adjacent clusters) of 1079.210 μm or 1142.694 μm , and an X axis cluster pitch of 1125 μm . An illustrative cluster **510** is depicted in **FIG. 7**, where the Y axis loci pitch (distance from center to center of adjacent loci) is 63.483 μm , and an X axis loci pitch is 75 μm . The locus width at the longest part, *e.g.*, diameter for a circular locus, is 50 μm and the distance between loci is 24 μm . The number of loci **705** in the exemplary cluster in **FIG. 7** is 121.

The loci may be flat, wells, or channels. An exemplary channel arrangement is illustrated in **FIGS. 8A-8B** where a plate **805** is illustrated comprising a main channel **810** and a plurality of channels **815** connected to the main channel **810**. The connection between the main channel **810** and the plurality of channels **815** provides for a fluid communication for flow paths from the main channel **810** to the each of the plurality of channels **815**. A plate **805** described herein can comprise multiple main channels **810**. The plurality of channels **815** collectively forms a cluster within the main channel **810**.

[0070] In the case of flexible structures, provided herein are devices wherein the flexible structure comprises a continuous loop **901** wrapped around one or more fixed structures, e.g., a pair of rollers **903** or a non-continuous flexible structure **907** wrapped around separate fixed structures, e.g., a pair reels **905**. *See FIGS. 9A-9B*. In some instances, the structures comprise multiple regions for polynucleotide synthesis. An exemplary structure is illustrated in **FIG. 9C** where a plate comprises distinct regions **909** for polynucleotide synthesis. The distinct regions **909** may be separated **911** by breaking or cutting. Each of the distinct regions may be further released, sequenced, decrypted, and read **913** or stored **915**. An alternative structure is illustrated in **FIG. 9D** in which a tape comprises distinct regions **917** for polynucleotide synthesis. The distinct regions **917** may be separated **919** by breaking or cutting. Each of the distinct regions may be further released, sequenced, decrypted, and read **921** or stored **923**. Provided herein are flexible structures having a surface with a plurality of loci for polynucleotide extension. **FIGS. 10A-10C** show a zoom in of the locus in the flexible structure. Each locus in a portion of the flexible structure **1001**, may be a substantially planar spot **1003** (e.g., flat), a channel **1005**, or a well **1007**. In one exemplary arrangement, each locus of the structure has a width of about 10 μm and a distance between the center of each structure of about 21 μm . *See FIG. 11A*. Loci may comprise, without limitation, circular, rectangular, tapered, or rounded shapes. Alternatively or in combination, the structures are rigid. In some instances, the rigid structures comprise loci, channels, or wells for polynucleotide synthesis.

[0071] In some instances, a channel described herein has a width to depth (or height) ratio of 1 to 0.01, wherein the width is a measurement of the width at the narrowest segment of the microchannel. In some instances, a channel described herein has a width to depth (or height) ratio of 0.5 to 0.01, wherein the width is a measurement of the width at the narrowest segment of the microchannel. In some instances, a channel described herein has a width to depth (or height) ratio of about 0.01, 0.05, 0.1, 0.15, 0.16, 0.2, 0.5, or 1.

[0072] Described herein are structures comprising a plurality of discrete loci, channels, or wells for polynucleotide synthesis. In some instances, structures described herein are provided

comprising a plurality of channels corresponding to a plurality of loci within a cluster, wherein the height or depth of the channel is from about 5 μm to about 500 μm , from about 5 μm to about 400 μm , from about 5 μm to about 300 μm , from about 5 μm to about 200 μm , from about 5 μm to about 100 μm , from about 5 μm to about 50 μm , or from about 10 μm to about 50 μm . In some cases, the height of a channel is less than 100 μm , less than 80 μm , less than 60 μm , less than 40 μm or less than 20 μm . In some cases, channel height is about 10, 20, 30, 40, 50, 60, 70, 80, 90, 100, 200, 300, 400, 500 μm or more. In some instances, the height or depth of the channel is at least 10, 25, 50, 75, 100, 200, 300, 400, 500, 600, 700, 800, 900, 1000, or more than 1000 nm. In some instances, the height or depth of the channel is in a range of about 10 nm to about 1000 nm, about 25 nm to about 900 nm, about 50 nm to about 800 nm, about 75 nm to about 700 nm, about 100 nm to about 600 nm, or about 200 nm to about 500.

[0073] In some instances, the width of a locus (*e.g.*, substantially planar spot, well, or channel) is from about 0.1 μm to about 500 μm , from about 0.5 μm to about 500 μm , from about 1 μm to about 200 μm , from about 1 μm to about 100 μm , from about 5 μm to about 100 μm , or from about 0.1 μm to about 100 μm , for example, about 90 μm , 80 μm , 70 μm , 60 μm , 50 μm , 40 μm , 30 μm , 20 μm , 10 μm , 5 μm , 1 μm or 0.5 μm . In some instances, the width of a locus (*e.g.*, microchannel) is less than about 100 μm , 90 μm , 80 μm , 70 μm , 60 μm , 50 μm , 40 μm , 30 μm , 20 μm or 10 μm . In some instances, the width of a locus is at least 10, 25, 50, 75, 100, 200, 300, 400, 500, 600, 700, 800, 900, 1000, or more than 1000 nm. In some instances, the width of a locus is in a range of about 10 nm to about 1000 nm, about 25 nm to about 900 nm, about 50 nm to about 800 nm, about 75 nm to about 700 nm, about 100 nm to about 600 nm, or about 200 nm to about 500. In some instances, the distance between the center of two adjacent loci is from about 0.1 μm to about 500 μm , 0.5 μm to about 500 μm , from about 1 μm to about 200 μm , from about 1 μm to about 100 μm , from about 5 μm to about 200 μm , from about 5 μm to about 100 μm , from about 5 μm to about 50 μm , or from about 5 μm to about 30 μm , for example, about 20 μm . In some instances, the total width of a locus is about 5 μm , 10 μm , 20 μm , 30 μm , 40 μm , 50 μm , 60 μm , 70 μm , 80 μm , 90 μm , or 100 μm . In some instances, the total width of a locus is about 1 μm to 100 μm , 30 μm to 100 μm , or 50 μm to 70 μm .

[0074] In some instances, each locus supports the synthesis of a population of polynucleotides having a different sequence than a population of polynucleotides grown on another locus. Provided herein are surfaces which comprise at least 10, 100, 256, 500, 1000, 2000, 3000, 4000, 5000, 6000, 7000, 8000, 9000, 10000, 11000, 12000, 13000, 14000, 15000, 20000, 30000, 40000, 50000 or more clusters. Provided herein are surfaces which comprise more than 2,000; 5,000; 10,000; 20,000; 30,000; 50,000; 100,000; 200,000; 300,000; 400,000; 500,000; 600,000; 700,000; 800,000;

900,000; 1,000,000; 5,000,000; or 10,000,000 or more distinct loci. In some cases, each cluster includes 1, 2, 3, 4, 5, 6, 7, 8, 9, 10, 20, 30, 40, 50, 60, 70, 80, 90, 100, 120, 130, 150, 200, 500 or more loci. In some cases, each cluster includes 50 to 500, 50 to 200, 50 to 150, or 100 to 150 loci. In some cases, each cluster includes 100 to 150 loci. In exemplary arrangements, each cluster includes 109, 121, 130 or 137 loci.

[0075] Provided herein are loci having a width at the longest segment of 5 to 100 μm . In some cases, the loci have a width at the longest segment of about 30, 35, 40, 45, 50, 55 or 60 μm . In some cases, the loci are channels having multiple segments, wherein each segment has a center to center distance apart of 5 to 50 μm . In some cases, the center to center distance apart for each segment is about 5, 10, 15, 20 or 25 μm .

[0076] In some instances, the number of distinct polynucleotides synthesized on the surface of a structure described herein is dependent on the number of distinct loci available in the substrate. In some instances, the density of loci within a cluster of a substrate is at least or about 1 locus per mm^2 , 10 loci per mm^2 , 25 loci per mm^2 , 50 loci per mm^2 , 65 loci per mm^2 , 75 loci per mm^2 , 100 loci per mm^2 , 130 loci per mm^2 , 150 loci per mm^2 , 175 loci per mm^2 , 200 loci per mm^2 , 300 loci per mm^2 , 400 loci per mm^2 , 500 loci per mm^2 , 1,000 loci per mm^2 or more. In some cases, a substrate comprises from about 10 loci per mm^2 to about 500 mm^2 , from about 25 loci per mm^2 to about 400 mm^2 , from about 50 loci per mm^2 to about 500 mm^2 , from about 100 loci per mm^2 to about 500 mm^2 , from about 150 loci per mm^2 to about 500 mm^2 , from about 10 loci per mm^2 to about 250 mm^2 , from about 50 loci per mm^2 to about 250 mm^2 , from about 10 loci per mm^2 to about 200 mm^2 , or from about 50 loci per mm^2 to about 200 mm^2 . In some instances, the distance between the centers of two adjacent loci within a cluster is from about 10 μm to about 500 μm , from about 10 μm to about 200 μm , or from about 10 μm to about 100 μm . In some cases, the distance between two centers of adjacent loci is greater than about 10 μm , 20 μm , 30 μm , 40 μm , 50 μm , 60 μm , 70 μm , 80 μm , 90 μm or 100 μm . In some cases, the distance between the centers of two adjacent loci is less than about 200 μm , 150 μm , 100 μm , 80 μm , 70 μm , 60 μm , 50 μm , 40 μm , 30 μm , 20 μm or 10 μm . In some cases, the distance between the centers of two adjacent loci is less than about 10000 nm, 8000 nm, 6000 nm, 4000 nm, 2000 nm 1000 nm, 800 nm, 600 nm, 400 nm, 200 nm, 150 nm, 100 nm, 80 nm, 70 nm, 60 nm, 50 nm, 40 nm, 30 nm, 20 nm or 10 nm. In some embodiments, each square meter of a structure described herein allows for at least about 10^7 , 10^8 , 10^9 , 10^{10} , 10^{11} loci, where each locus supports one polynucleotide. In some embodiments, 10^9 polynucleotides are supported on less than about 6, 5, 4, 3, 2 or 1 m^2 of a structure described herein.

[0077] In some instances, a structure described herein provides support for the synthesis of more than 2,000; 5,000; 10,000; 20,000; 30,000; 50,000; 100,000; 200,000; 300,000; 400,000; 500,000;

600,000; 700,000; 800,000; 900,000; 1,000,000; 1,200,000; 1,400,000; 1,600,000; 1,800,000; 2,000,000; 2,500,000; 3,000,000; 3,500,000; 4,000,000; 4,500,000; 5,000,000; 10,000,000 or more non-identical polynucleotides. In some cases, the structure provides support for the synthesis of more than 2,000; 5,000; 10,000; 20,000; 50,000; 100,000; 200,000; 300,000; 400,000; 500,000; 600,000; 700,000; 800,000; 900,000; 1,000,000; 1,200,000; 1,400,000; 1,600,000; 1,800,000; 2,000,000; 2,500,000; 3,000,000; 3,500,000; 4,000,000; 4,500,000; 5,000,000; 10,000,000 or more polynucleotides encoding for distinct sequences. In some instances, at least a portion of the polynucleotides have an identical sequence or are configured to be synthesized with an identical sequence. In some instances, the structure provides a surface environment for the growth of polynucleotides having at least about 50, 60, 70, 75, 80, 85, 90, 95, 100, 110, 120, 130, 140, 150, 160, 175, 200, 225, 250, 275, 300, 325, 350, 375, 400, 425, 450, 475, 500 bases or more. In some arrangements, structures for polynucleotide synthesis described herein comprise sites for polynucleotide synthesis in a uniform arrangement.

[0078] In some instances, polynucleotides are synthesized on distinct loci of a structure, wherein each locus supports the synthesis of a population of polynucleotides. In some cases, each locus supports the synthesis of a population of polynucleotides having a different sequence than a population of polynucleotides grown on another locus. In some instances, the loci of a structure are located within a plurality of clusters. In some instances, a structure comprises at least 10, 500, 1000, 2000, 3000, 4000, 5000, 6000, 7000, 8000, 9000, 10000, 11000, 12000, 13000, 14000, 15000, 20000, 30000, 40000, 50000 or more clusters. In some instances, a structure comprises more than 2,000; 5,000; 10,000; 100,000; 200,000; 300,000; 400,000; 500,000; 600,000; 700,000; 800,000; 900,000; 1,000,000; 1,100,000; 1,200,000; 1,300,000; 1,400,000; 1,500,000; 1,600,000; 1,700,000; 1,800,000; 1,900,000; 2,000,000; 300,000; 400,000; 500,000; 600,000; 700,000; 800,000; 900,000; 1,000,000; 1,200,000; 1,400,000; 1,600,000; 1,800,000; 2,000,000; 2,500,000; 3,000,000; 3,500,000; 4,000,000; 4,500,000; 5,000,000; or 10,000,000 or more distinct loci. In some cases, each cluster includes 1, 2, 3, 4, 5, 6, 7, 8, 9, 10, 20, 30, 40, 50, 60, 70, 80, 90, 100, 120, 130, 150 or more loci. In some instances, each cluster includes 50 to 500, 100 to 150, or 100 to 200 loci. In some instances, each cluster includes 109, 121, 130 or 137 loci. In some instances, each cluster includes 5, 6, 7, 8, 9, 10, 11 or 12 loci. In some instances, polynucleotides from distinct loci within one cluster have sequences that, when assembled, encode for a contiguous longer polynucleotide of a predetermined sequence.

[0079] Structure size

[0080] In some instances, a structure described herein is about the size of a standard 96 well plate, for example between about 100 and 200 mm by between about 50 and 150 mm. In some

instances, a structure described herein has a diameter less than or equal to about 1000 mm, 500 mm, 450 mm, 400 mm, 300 mm, 250 mm, 200 mm, 150 mm, 100 mm or 50 mm. In some instances, the diameter of a substrate is between about 25 mm and 1000 mm, between about 25 mm and about 800 mm, between about 25 mm and about 600 mm, between about 25 mm and about 500 mm, between about 25 mm and about 400 mm, between about 25 mm and about 300 mm, or between about 25 mm and about 200. Non-limiting examples of substrate size include about 300 mm, 200 mm, 150 mm, 130 mm, 100 mm, 76 mm, 51 mm and 25 mm. In some instances, a substrate has a planar surface area of at least about 100 mm²; 200 mm²; 500 mm²; 1,000 mm²; 2,000 mm²; 5,000 mm²; 10,000 mm²; 12,000 mm²; 15,000 mm²; 20,000 mm²; 30,000 mm²; 40,000 mm²; 50,000 mm² or more. In some instances, the thickness is between about 50 mm and about 2000 mm, between about 50 mm and about 1000 mm, between about 100 mm and about 1000 mm, between about 200 mm and about 1000 mm, or between about 250 mm and about 1000 mm. Non-limiting examples thickness include 275 mm, 375 mm, 525 mm, 625 mm, 675 mm, 725 mm, 775 mm and 925 mm. In some cases, the thickness of varies with diameter and depends on the composition of the substrate. For example, a structure comprising materials other than silicon may have a different thickness than a silicon structure of the same diameter. Structure thickness may be determined by the mechanical strength of the material used and the structure must be thick enough to support its own weight without cracking during handling. In some instances, a structure is more than about 1, 2, 3, 4, 5, 10, 15, 30, 40, 50 feet in any one dimension.

[0081] Materials

[0082] Provided herein are devices comprising a surface, wherein the surface is modified to support polynucleotide synthesis at predetermined locations and with a resulting low error rate, a low dropout rate, a high yield, and a high oligo representation. In some embodiments, surfaces of devices for polynucleotide synthesis provided herein are fabricated from a variety of materials capable of modification to support a de novo polynucleotide synthesis reaction. In some cases, the devices are sufficiently conductive, e.g., are able to form uniform electric fields across all or a portion of the devices. Devices described herein may comprise a flexible material. Exemplary flexible materials include, without limitation, modified nylon, unmodified nylon, nitrocellulose, and polypropylene. Devices described herein may comprise a rigid material. Exemplary rigid materials include, without limitation, glass, fused silica, silicon, silicon dioxide, silicon nitride, plastics (for example, polytetrafluoroethylene, polypropylene, polystyrene, polycarbonate, and blends thereof, and metals (for example, gold, platinum). Devices disclosed herein may be fabricated from a material comprising silicon, polystyrene, agarose, dextran, cellulosic polymers, polyacrylamides, polydimethylsiloxane (PDMS), glass, or any combination thereof. In some cases,

devices disclosed herein is manufactured with a combination of materials listed herein or any other suitable material known in the art.

[0083] Devices described herein may comprise material having a range of tensile strength. Exemplary materials having a range of tensile strengths include, but are not limited to, nylon (70 MPa), nitrocellulose (1.5 MPa), polypropylene (40 MPa), silicon (268 MPa), polystyrene (40 MPa), agarose (1-10 MPa), polyacrylamide (1-10 MPa), polydimethylsiloxane (PDMS) (3.9-10.8 MPa). Solid supports described herein can have a tensile strength from 1 to 300, 1 to 40, 1 to 10, 1 to 5, or 3 to 11 MPa. Solid supports described herein can have a tensile strength of about 1, 1.5, 2, 3, 4, 5, 6, 7, 8, 9, 10, 11, 20, 25, 40, 50, 60, 70, 80, 90, 100, 150, 200, 250, 270, or more MPa. In some instances, a device described herein comprises a solid support for polynucleotide synthesis that is in the form of a flexible material capable of being stored in a continuous loop or reel, such as a tape or flexible sheet.

[0084] Young's modulus measures the resistance of a material to elastic (recoverable) deformation under load. Exemplary materials having a range of Young's modulus stiffness include, but are not limited to, nylon (3 GPa), nitrocellulose (1.5 GPa), polypropylene (2 GPa), silicon (150 GPa), polystyrene (3 GPa), agarose (1-10 GPa), polyacrylamide (1-10 GPa), polydimethylsiloxane (PDMS) (1-10 GPa). Solid supports described herein can have a Young's moduli from 1 to 500, 1 to 40, 1 to 10, 1 to 5, or 3 to 11 GPa. Solid supports described herein can have a Young's moduli of about 1, 1.5, 2, 3, 4, 5, 6, 7, 8, 9, 10, 11, 20, 25, 40, 50, 60, 70, 80, 90, 100, 150, 200, 250, 400, 500 GPa, or more. As the relationship between flexibility and stiffness are inverse to each other, a flexible material has a low Young's modulus and changes its shape considerably under load. In some instances, a solid support described herein has a surface with a flexibility of at least nylon.

[0085] In some cases, devices disclosed herein comprises a silicon dioxide base and a surface layer of silicon oxide. Alternatively, the devices may have a base of silicon oxide. Surface of the devices provided here may be textured, resulting in an increase overall surface area for polynucleotide synthesis. Devices disclosed herein may comprise at least 5 %, 10%, 25%, 50%, 80%, 90%, 95%, or 99% silicon. Devices disclosed herein may be fabricated from a silicon on insulator (SOI) wafer.

[0086] The structure may be fabricated from a variety of materials, suitable for the methods and compositions of the invention described herein. In certain embodiments, the materials from which the substrates/ solid supports of the comprising the invention are fabricated exhibit a low level of oligonucleotide binding. In some situations, material that are transparent to visible and/or UV light can be employed. Materials that are sufficiently conductive, e.g. those that can form uniform

electric fields across all or a portion of the substrates/solids support described herein, can be utilized. In some embodiments, such materials may be connected to an electric ground. In some cases, the substrate or solid support can be heat conductive or insulated. The materials can be chemical resistant and heat resistant to support chemical or biochemical reactions such as a series of oligonucleotide synthesis reaction. For flexible materials, materials of interest can include: nylon, both modified and unmodified, nitrocellulose, polypropylene, and the like.

[0087] For rigid materials, specific materials of interest include: glass; fuse silica; silicon, plastics (for example polytetrafluoroethylene, polypropylene, polystyrene, polycarbonate, and blends thereof, and the like); metals (for example, gold, platinum, and the like). The structure can be fabricated from a material selected from the group consisting of silicon, polystyrene, agarose, dextran, cellulosic polymers, polyacrylamides, polydimethylsiloxane (PDMS), and glass. The substrates/solid supports or the microstructures, reactors therein may be manufactured with a combination of materials listed herein or any other suitable material known in the art.

[0088] The term “flexible” is used herein to refer to a structure that is capable of being bent, folded or similarly manipulated without breakage. In some cases, a flexible structure is bent at least 30 degrees around a roller. In some cases, a flexible structure is bent at least 180 degrees around a roller. In some cases, a flexible structure is bent at least 270 degrees around a roller. In some instances, a flexible structure is bent about 360 degrees around a roller. In some cases, the roller is less than about 10 cm, 5 cm, 3 cm, 2 cm or 1cm in radius. In some instances, the flexible structure is bent and straightened repeatedly in either direction at least 100 times without failure (for example, cracking) or deformation at 20° C. In some instances, a flexible structure described herein has a thickness that is amenable to rolling. In some cases, the thickness of the flexible structure described herein is less than about 50 mm, 10 mm, 1 mm, or 0.5 mm.

[0089] Exemplary flexible materials for structure described herein include, without limitation, nylon (unmodified nylon, modified nylon, clear nylon), nitrocellulose, polypropylene, polycarbonate, polyethylene, polyurethane, polystyrene, acetal, acrylic, acrylonitrile, butadiene styrene (ABS), polyester films such as polyethylene terephthalate, polymethyl methacrylate or other acrylics, polyvinyl chloride or other vinyl resin, transparent PVC foil, transparent foil for printers, Poly(methyl methacrylate) (PMMA), methacrylate copolymers, styrenic polymers, high refractive index polymers, fluorine-containing polymers, polyethersulfone, polyimides containing an alicyclic structure, rubber, fabric, metal foils, and any combination thereof. Various plasticizers and modifiers may be used with polymeric substrate materials to achieve selected flexibility characteristics.

[0090] Flexible structures described herein may comprise a plastic material. In some instances, the flexible structure comprises a thermoplastic material. Non-limiting examples of thermoplastic materials include acrylic, acrylonitrile butadiene styrene, nylon, polylactic acid, polybenzimidazole, polycarbonate, polyether sulfone, polyetherether ketone, polyetherimide, polyethylene, polyphenylene oxide, polyphenylene sulfide, polypropylene, polystyrene, polyvinyl chloride, and polytetrafluoroethylene. In some embodiments, the substrate comprises a thermoplastic material in the polyaryletherketone (PEAK) family. Non-limiting examples of PEAK thermoplastics include polyetherketone (PEK), polyetherketoneketone (PEKK), poly(ether ether ketone ketone) (PEEKK), polyether ether ketone (PEEK), and polyetherketoneetherketoneketone (PEKEKK). In some instances, the flexible structure comprises a thermoplastic material compatible with toluene. In some instances, the flexibility of the plastic material is increased by the addition of a plasticizer. An example of a plasticizer is an ester-based plasticizer, such as phthalate. Phthalate plasticizers include bis(2-ethylhexyl) phthalate (DEHP), diisononyl phthalate (DINP), di-n-butyl phthalate (DnBP, DBP), butyl benzyl phthalate (BBzP), diisodecyl phthalate (DIDP), dioctyl phthalate (DOP, DnOP), diisooctyl phthalate (DIOP), diethyl phthalate (DEP), diisobutyl phthalate (DIBP), and di-n-hexyl phthalate. In some instances, modification of the thermoplastic polymer through copolymerization or through the addition of non-reactive side chains to monomers before polymerization also increases flexibility.

[0091] Provided herein are flexible structures which may further comprise a fluoroelastomer. Materials having about 80% fluoroelastomers are designated as FKMs. Fluoroelastomers include perfluoro-elastomers (FFKMs) and tetrafluoroethylene/propylene rubbers (FEPM). Fluoroelastomers have five known types. Type 1 FKMs are composed of vinylidene fluoride (VDF) and hexafluoropropylene (HFP) and their fluorine content typically is around 66% by weight. Type 2 FKMs are composed of VDF, HFP, and tetrafluoroethylene (TFE) and typically have between about 68% and 69% fluorine. Type 3 FKMs are composed of VDF, TFE, and perfluoromethylvinylether (PMVE) and typically have between about 62% and 68% fluorine. Type 4 FKMs are composed of propylene, TFE, and VDF and typically have about 67% fluorine. Type 5 FKMs are composed of VDF, HFP, TFE, PMVE, and ethylene.

[0092] In some instances, a substrate disclosed herein comprises a computer readable material. Computer readable materials include, without limitation, magnetic media, reel-to-reel tape, cartridge tape, cassette tape, flexible disk, paper media, film, microfiche, continuous tape (e.g., a belt) and any media suitable for storing electronic instructions. In some cases, the substrate comprises magnetic reel-to-reel tape or a magnetic belt. In some instances, the substrate comprises a flexible printed circuit board.

[0093] Structures described herein may be transparent to visible and/or UV light. In some instances, structures described herein are sufficiently conductive to form uniform electric fields across all or a portion of a structure. In some instances, structures described herein are heat conductive or insulated. In some instances, the structures are chemical resistant and heat resistant to support a chemical reaction such as a polynucleotide synthesis reaction. In some embodiments, the substrate is magnetic. In some instances, the structures comprise a metal or a metal alloy.

[0094] Structures for polynucleotide synthesis may be over 1, 2, 5, 10, 30, 50 or more feet long in any dimension. In the case of a flexible structure, the flexible structure is optionally stored in a wound state, e.g., in a reel. In the case of a large rigid structure, e.g., greater than 1 foot in length, the rigid structure can be stored vertically or horizontally.

[0095] Encryption key markings on the structure's surface

[0096] Provided herein are structures having markings **1101** wherein the markings provide information relating to the source item of information associated with a nearby population of polynucleotides, an encryption scheme for decrypting the sequence of the nearby population of polynucleotides, the copy number for the nearby population of polynucleotides, or any combination thereof. *See, e.g., FIGS. 11B-11C.* The markings may be visible to the naked eye, or visible under a magnified view using a microscope. In some instances, the markings on the surface are only visible after a treatment condition to expose the marking, such as a heat, chemical or light treatment (e.g., UV or IR light to illuminate the marking). An example ink developed by heat includes, without limitation, cobalt chloride, (which turns blue when heated). Example inks developed by chemical reaction include, without limitation, phenolphthalein, copper sulfate, lead(II) nitrate, cobalt(II) chloride, and cerium oxalate developed by manganese sulfate and hydrogen peroxide.

[0097] Surface Preparation

[0098] Provided herein are methods to support the immobilization of a biomolecule on a substrate, where a surface of a structure described herein comprises a material and/or is coated with a material that facilitates a coupling reaction with the biomolecule for attachment. To prepare a structure for biomolecule immobilization, surface modifications may be employed that chemically and/or physically alter the substrate surface by an additive or subtractive process to change one or more chemical and/or physical properties of a substrate surface or a selected site or region of the surface. For example, surface modification involves (1) changing the wetting properties of a surface, (2) functionalizing a surface, i.e. providing, modifying or substituting surface functional groups, (3) defunctionalizing a surface, i.e. removing surface functional groups, (4) otherwise altering the chemical composition of a surface, e.g., through etching, (5) increasing or decreasing surface roughness, (6) providing a coating on a surface, e.g., a coating that exhibits wetting

properties that are different from the wetting properties of the surface, and/or (7) depositing particulates on a surface. In some instances, the surface of a structure is selectively functionalized to produce two or more distinct areas on a structure, wherein at least one area has a different surface or chemical property than another area of the same structure. Such properties include, without limitation, surface energy, chemical termination, surface concentration of a chemical moiety, and the like.

[0099] In some instances, a surface of a structure disclosed herein is modified to comprise one or more actively functionalized surfaces configured to bind to both the surface of the substrate and a biomolecule, thereby supporting a coupling reaction to the surface. In some instances, the surface is also functionalized with a passive material that does not efficiently bind the biomolecule, thereby preventing biomolecule attachment at sites where the passive functionalization agent is bound. In some cases, the surface comprises an active layer only defining distinct loci for biomolecule support.

[00100] In some embodiments, the surface is contacted with a mixture of functionalization groups which are in any different ratio. In some embodiments, a mixture comprises at least 2, 3, 4, 5 or more different types of functionalization agents. In some cases, the ratio of the at least two types of surface functionalization agents in a mixture is about 1:1, 1:2, 1:5, 1:10, 2:10, 3:10, 4:10, 5:10, 6:10, 7:10, 8:10, 9:10, or any other ratio to achieve a desired surface representation of two groups. In some embodiments, desired surface tensions, wettabilities, water contact angles, and/or contact angles for other suitable solvents are achieved by providing a substrate surface with a suitable ratio of functionalization agents. In some cases, the agents in a mixture are chosen from suitable reactive and inert moieties, thus diluting the surface density of reactive groups to a desired level for downstream reactions. In some embodiments, the mixture of functionalization reagents comprises one or more reagents that bind to a biomolecule and one or more reagents that do not bind to a biomolecule. Therefore, modulation of the reagents allows for the control of the amount of biomolecule binding that occurs at a distinct area of functionalization.

[00101] In some instances, a method for substrate functionalization comprises deposition of a silane molecule onto a surface of a substrate. The silane molecule may be deposited on a high energy surface of the substrate. In some instances the high surface energy region includes a passive functionalization reagent. Methods described herein provide for a silane group to bind the surface, while the rest of the molecule provides a distance from the surface and a free hydroxyl group at the end to which a biomolecule attaches. In some instances, the silane is an organofunctional alkoxy silane molecule. Non-limiting examples of organofunctional alkoxy silane molecules include dimethylchloro-octodecyl-silane, methylchloro-octodecyl-silane, trichloro-octodecyl-silane, and

trimethyl-octodecyl-silane, triethyl-octodecyl-silane. In some instances, the silane is an amino silane. Examples of amino silanes include, without limitation, 11-acetoxyundecyltriethoxysilane, n-decyltriethoxysilane, (3-aminopropyl)trimethoxysilane, (3-aminopropyl)triethoxysilane, glycidyoxypropyl/trimethoxysilane and N-(3-triethoxysilylpropyl)-4-hydroxybutyramide. In some instances, the silane comprises 11-acetoxyundecyltriethoxysilane, n-decyltriethoxysilane, (3-aminopropyl)trimethoxysilane, (3-aminopropyl)triethoxysilane, glycidyoxypropyl/trimethoxysilane, N-(3-triethoxysilylpropyl)-4-hydroxybutyramide, or any combination thereof. In some instances, an active functionalization agent comprises 11-acetoxyundecyltriethoxysilane. In some instances, an active functionalization agent comprises n-decyltriethoxysilane. In some cases, an active functionalization agent comprises glycidyoxypropyltriethoxysilane (GOPS). In some embodiments, the silane is a fluorosilane. In some embodiments, the silane is a hydrocarbon silane. In some cases, the silane is 3-iodopropyltrimethoxysilane. In some cases, the silane is octylchlorosilane.

[00102] In some embodiments, silanization is performed on a surface through self-assembly with organofunctional alkoxy silane molecules. The organofunctional alkoxy silanes are classified according to their organic functions. Non-limiting examples of siloxane functionalizing reagents include hydroxyalkyl siloxanes (silylate surface, functionalizing with diborane and oxidizing the alcohol by hydrogen peroxide), diol (dihydroxyalkyl) siloxanes (silylate surface, and hydrolyzing to diol), aminoalkyl siloxanes (amines require no intermediate functionalizing step), glycidoxysilanes (3-glycidoxypropyl-dimethyl-ethoxysilane, glycidoxy-trimethoxysilane), mercaptosilanes (3-mercaptopropyl-trimethoxysilane, 3-4 epoxycyclohexyl-ethyltrimethoxysilane or 3-mercaptopropyl-methyl-dimethoxysilane), bicycloheptenyl-trichlorosilane, butyl-aldehyde-trimethoxysilane, or dimeric secondary aminoalkyl siloxanes. Exemplary hydroxyalkyl siloxanes include allyl trichlorochlorosilane turning into 3-hydroxypropyl, or 7-oct-1-enyl trichlorochlorosilane turning into 8-hydroxyoctyl. The diol (dihydroxyalkyl) siloxanes include glycidyl trimethoxysilane-derived (2,3-dihydroxypropyloxy)propyl (GOPS). The aminoalkyl siloxanes include 3-aminopropyl trimethoxysilane turning into 3-aminopropyl (3-aminopropyl-triethoxysilane, 3-aminopropyl-diethoxy-methylsilane, 3-aminopropyl-dimethyl-ethoxysilane, or 3-aminopropyl-trimethoxysilane). In some cases, the dimeric secondary aminoalkyl siloxanes is bis(3-trimethoxysilylpropyl) amine turning into bis(silyloxypropyl)amine.

[00103] Active functionalization areas may comprise one or more different species of silanes, for example, 1, 2, 3, 4, 5, 6, 7, 8, 9, 10 or more silanes. In some cases, one of the one or more silanes is present in the functionalization composition in an amount greater than another silane. For example, a mixed silane solution having two silanes comprises a 99:1, 98:2, 97:3, 96:4, 95:5, 94:6, 93:7,

92:8, 91:9, 90:10, 89:11, 88:12, 87:13, 86:14, 85:15, 84:16, 83:17, 82:18, 81:19, 80:20, 75:25, 70:30, 65:35, 60:40, 55:45 ratio of one silane to another silane. In some instances, an active functionalization agent comprises 11-acetoxyundecyltriethoxysilane and n-decyltriethoxysilane. In some instances, an active functionalization agent comprises 11-acetoxyundecyltriethoxysilane and n-decyltriethoxysilane in a ratio from about 20:80 to about 1:99, or about 10:90 to about 2:98, or about 5:95.

[00104] In some instances, functionalization comprises deposition of a functionalization agent to a structure by any deposition technique, including, but not limiting to, chemical vapor deposition (CVD), atomic layer deposition (ALD), plasma enhanced CVD (PECVD), plasma enhanced ALD (PEALD), metal organic CVD (MOCVD), hot wire CVD (HWCVD), initiated CVD (iCVD), modified CVD (MCVD), vapor axial deposition (VAD), outside vapor deposition (OVD), physical vapor deposition (*e.g.*, sputter deposition, evaporative deposition), and molecular layer deposition (MLD).

[00105] Any step or component in the following functionalization process be omitted or changed in accordance with properties desired of the final functionalized substrate. In some cases, additional components and/or process steps are added to the process workflows embodied herein. In some instances, a substrate is first cleaned, for example, using a piranha solution. An example of a cleaning process includes soaking a substrate in a piranha solution (*e.g.*, 90% H₂SO₄, 10% H₂O₂) at an elevated temperature (*e.g.*, 120 °C) and washing (*e.g.*, water) and drying the substrate (*e.g.*, nitrogen gas). The process optionally includes a post piranha treatment comprising soaking the piranha treated substrate in a basic solution (*e.g.*, NH₄OH) followed by an aqueous wash (*e.g.*, water). In some instances, a surface of a structure is plasma cleaned, optionally following the piranha soak and optional post piranha treatment. An example of a plasma cleaning process comprises an oxygen plasma etch. In some instances, the surface is deposited with an active functionalization agent following by vaporization. In some instances, the substrate is actively functionalized prior to cleaning, for example, by piranha treatment and/or plasma cleaning.

[00106] The process for surface functionalization optionally comprises a resist coat and a resist strip. In some instances, following active surface functionalization, the substrate is spin coated with a resist, for example, SPR™ 3612 positive photoresist. The process for surface functionalization, in various instances, comprises lithography with patterned functionalization. In some instances, photolithography is performed following resist coating. In some instances, after lithography, the surface is visually inspected for lithography defects. The process for surface functionalization, in some instances, comprises a cleaning step, whereby residues of the substrate are removed, for

example, by plasma cleaning or etching. In some instances, the plasma cleaning step is performed at some step after the lithography step.

[00107] In some instances, a surface coated with a resist is treated to remove the resist, for example, after functionalization and/or after lithography. In some cases, the resist is removed with a solvent, for example, with a stripping solution comprising N-methyl-2-pyrrolidone. In some cases, resist stripping comprises sonication or ultrasonication. In some instances, a resist is coated and stripped, followed by active functionalization of the exposed areas to create a desired differential functionalization pattern.

[00108] In some instances, the methods and compositions described herein relate to the application of photoresist for the generation of modified surface properties in selective areas, wherein the application of the photoresist relies on the fluidic properties of the surface defining the spatial distribution of the photoresist. Without being bound by theory, surface tension effects related to the applied fluid may define the flow of the photoresist. For example, surface tension and/or capillary action effects may facilitate drawing of the photoresist into small structures in a controlled fashion before the resist solvents evaporate. In some instances, resist contact points are pinned by sharp edges, thereby controlling the advance of the fluid. The underlying structures may be designed based on the desired flow patterns that are used to apply photoresist during the manufacturing and functionalization processes. A solid organic layer left behind after solvents evaporate may be used to pursue the subsequent steps of the manufacturing process. Structures may be designed to control the flow of fluids by facilitating or inhibiting wicking effects into neighboring fluidic paths. For example, a structure is designed to avoid overlap between top and bottom edges, which facilitates the keeping of the fluid in top structures allowing for a particular disposition of the resist. In an alternative example, the top and bottom edges overlap, leading to the wicking of the applied fluid into bottom structures. Appropriate designs may be selected accordingly, depending on the desired application of the resist.

[00109] In some instances, a structure described herein has a surface that comprises a material having thickness of at least or at least about 0.1 nm, 0.5 nm, 1 nm, 2 nm, 5 nm, 10 nm or 25 nm that comprises a reactive group capable of binding nucleosides. Exemplary include, without limitation, glass and silicon, such as silicon dioxide and silicon nitride. In some cases, exemplary surfaces include nylon and PMMA.

[00110] In some instances, electromagnetic radiation in the form of UV light is used for surface patterning. In some instances, a lamp is used for surface patterning, and a mask mediates exposure locations of the UV light to the surface. In some instances, a laser is used for surface patterning, and a shutter opened/closed state controls exposure of the UV light to the surface. The laser

arrangement may be used in combination with a flexible structure that is capable of moving. In such an arrangement, the coordination of laser exposure and flexible structure movement is used to create patterns of one or more agents having differing nucleoside coupling capabilities.

[00111] Material Deposition Systems

[00112] Provided herein are systems and devices for the deposition and storage of biomolecules on a structure described herein. In some embodiments, the biomolecules are polynucleotides that store encoded information in their sequences. In some embodiments, the system comprises a surface of a structure to support biomolecule attachment and/or a device for application of a biomolecule to the surface of the substrate. In an example, the device for biomolecule application is a polynucleotide synthesizer. In some embodiments, the system comprises a device for treating the substrate with a fluid, for example, a flow cell. In some embodiments, the system comprises a device for moving the substrate between the application device and the treatment device. For instances where the substrate is a reel-to-reel tape, the system may comprise two or more reels that allow for access of different portions of the substrate to the application and optional treatment device at different times.

[00113] A first example of a polynucleotide material deposition system for polynucleotide synthesis is shown in **FIG. 12**. The system includes a material deposition device that moves in the X-Y direction to align with the location of the substrate. The material deposition device can also move in the Z direction to seal with the substrate, forming a resolved reactor. A resolved reactor is configured to allow for the transfer of fluid, including polynucleotides and/or reagents, from the substrate to a capping element and/or vice versa. As shown in **FIG. 12**, fluid may pass through either or both the substrate and the capping element and includes, without limitation, coupling reagents, capping reagents, oxidizers, de-blocking agents, acetonitrile and nitrogen gas. Examples of devices that are capable of high resolution droplet deposition include the printhead of inkjet printers and laser printers. The devices useful in the systems and methods described herein achieve a resolution from about 100 dots per inch (DPI) to about 50,000 DPI; from about 100 DPI to about 20,000 DPI; from about 100 DPI to about 10,000 DPI; from about 100 DPI to about 5,000 DPI; from about 1,000 DPI to about 20,000 DPI; or from about 1,000 DPI to about 10,000 DPI. In some instances, the devices have a resolution at least about 1,000; 2,000; 3,000; 4,000; 5,000; 10,000; 12,000 DPI, or 20,000 DPI. The high resolution deposition performed by the device is related to the number and density of each nozzle that corresponds to a feature of the substrate.

[00114] An exemplary process workflow for de novo synthesis of a polynucleotide on a substrate using a polynucleotide synthesizer is shown in **FIG. 13**. Droplets comprising polynucleotide synthesis reagents are released from the material deposition device to the substrate in a stepwise manner, wherein the material deposition device has a piezo ceramic material and electrodes to

convert electrical signals into a mechanical signal for releasing the droplets. The droplets are released to specific locations on the surface of the substrate one nucleobase at a time to generate a plurality of synthesized polynucleotides having predetermined sequences that encode data. In some cases, the synthesized polynucleotides are stored on the substrate. Nucleic acid reagents may be deposited on the substrate surface in a non-continuous, or drop-on-demand method. Examples of such methods include the electromechanical transfer method, electric thermal transfer method, and electrostatic attraction method. In the electromechanical transfer method, piezoelectric elements deformed by electrical pulses cause the droplets to be ejected. In the electric thermal transfer method, bubbles are generated in a chamber of the device, and the expansive force of the bubbles causes the droplets to be ejected. In the electrostatic attraction method, electrostatic force of attraction is used to eject the droplets onto the substrate. In some cases, the drop frequency is from about 5 KHz to about 500 KHz; from about 5 KHz to about 100 KHz; from about 10 KHz to about 500 KHz; from about 10 KHz to about 100 KHz; or from about 50 KHz to about 500 KHz. In some cases, the frequency is less than about 500 KHz, 200 KHz, 100 KHz, or 50 KHz.

[00115] The size of the droplets dispensed correlates to the resolution of the device. In some instances, the devices deposit droplets of reagents at sizes from about 0.01 pl to about 20 pl, from about 0.01 pl to about 10 pl, from about 0.01 pl to about 1 pl, from about 0.01 pl to about 0.5 pl, from about 0.01 pl to about 0.01 pl, or from about 0.05 pl to about 1 pl. In some instances, the droplet size is less than about 1 pl, 0.5 pl, 0.2 pl, 0.1 pl, or 0.05 pl. The size of droplets dispensed by the device is correlated to the diameters of deposition nozzles, wherein each nozzle is capable of depositing a reagent onto a feature of the substrate. In some instances, a deposition device of a polynucleotide synthesizer comprises from about 100 to about 10,000 nozzles; from about 100 to about 5,000 nozzles; from about 100 to about 3,000 nozzles; from about 500 to about 10,000 nozzles; or from about 100 to about 5,000 nozzles. In some cases, the deposition device comprises greater than 1,000; 2,000; 3,000; 4,000; 5,000; or 10,000 nozzles. In some instances, each material deposition device comprises a plurality of nozzles, where each nozzle is optionally configured to correspond to a feature on a substrate. Each nozzle may deposit a reagent component that is different from another nozzle. In some instances, each nozzle deposits a droplet that covers one or more features of the substrate. In some embodiments, one or more nozzles are angled. In some embodiments, multiple deposition devices are stacked side by side to achieve a fold increase in throughput. In some cases, the gain is 2x, 4x, 8x or more. An example of a deposition device is Samba Printhead (Fujifilm). A Samba Printhead may be used with the Samba Web Administration Tool (SWAT).

[00116] The number of deposition sites may be increased by using and rotating the same deposition device by a certain degree or saber angle. By rotating the deposition device, each nozzle is jetted with a certain amount of delay time corresponding to the saber angle. This unsynchronized jetting creates a cross talk among the nozzles. Therefore, when the droplets are jetting at a certain saber angle different from 0 degrees, the droplet volume from the nozzle could be different.

[00117] In some arrangements, the configuration of a polynucleotide synthesis system allows for a continuous polynucleotide synthesis process that exploits the flexibility of a substrate for traveling in a reel-to-reel type process. This synthesis process operates in a continuous production line manner with the substrate travelling through various stages of polynucleotide synthesis using one or more reels to rotate the position of the substrate. In an exemplary embodiment, a polynucleotide synthesis reaction comprises rolling a substrate: through a solvent bath, beneath a deposition device for phosphoramidite deposition, through a bath of oxidizing agent, through an acetonitrile wash bath, and through a deblock bath. Optionally, the tape is also traversed through a capping bath. A reel-to-reel type process allows for the finished product of a substrate comprising synthesized polynucleotides to be easily gathered on a take-up reel, where it can be transported for further processing or storage.

[00118] In some arrangements, polynucleotide synthesis proceeds in a continuous process as a continuous flexible tape is conveyed along a conveyor belt system. Similar to the reel-to-reel type process, polynucleotide synthesis on a continuous tape operates in a production line manner, with the substrate travelling through various stages of polynucleotide synthesis during conveyance. However, in a conveyor belt process, the continuous tape revisits a polynucleotide synthesis step without rolling and unrolling of the tape, as in a reel-to-reel process. In some arrangements, polynucleotide synthesis steps are partitioned into zones and a continuous tape is conveyed through each zone one or more times in a cycle. For example, a polynucleotide synthesis reaction may comprise (1) conveying a substrate through a solvent bath, beneath a deposition device for phosphoramidite deposition, through a bath of oxidizing agent, through an acetonitrile wash bath, and through a block bath in a cycle; and then (2) repeating the cycles to achieve synthesized polynucleotides of a predetermined length. After polynucleotide synthesis, the flexible substrate is removed from the conveyor belt system and, optionally, rolled for storage. Rolling may be around a reel, for storage.

[00119] In an exemplary arrangement, a flexible substrate comprising thermoplastic material is coated with nucleoside coupling reagent. The coating is patterned into loci such that each locus has diameter of about 10 μm , with a center-to-center distance between two adjacent loci of about 21 μm . In this instance, the locus size is sufficient to accommodate a sessile drop volume of 0.2 μl

during a polynucleotide synthesis deposition step. In some cases, the locus density is about 2.2 billion loci per m² (1 locus / 441 x 10⁻¹² m²). In some cases, a 4.5 m² substrate comprise about 10 billion loci, each with a 10 um diameter.

[00120] A material deposition device described herein may comprises about 2,048 nozzles that each deposit about 100,000 droplets per second at 1 nucleobase per droplet. For each deposition device, at least about 1.75 x 10¹³ nucleobases are deposited on the substrate per day. In some instances, 100 to 500 nucleobase polynucleotides are synthesized. In some cases, 200 nucleobase polynucleotides are synthesized. Optionally, over 3 days, at a rate of about 1.75 x 10¹³ bases per day, at least about 262.5 x 10⁹ polynucleotides are synthesized.

[00121] In some arrangements, a device for application of one or more reagents to a substrate during a synthesis reaction is configured to deposit reagents and /or nucleotide monomers for nucleoside phosphoramidite based synthesis. Reagents for polynucleotide synthesis include reagents for polynucleotide extension and wash buffers. As non-limiting examples, the device deposits cleaning reagents, coupling reagents, capping reagents, oxidizers, de-blocking agents, acetonitrile, gases such as nitrogen gas, and any combination thereof. In addition, the device optionally deposits reagents for the preparation and/or maintenance of substrate integrity. In some embodiments, the polynucleotide synthesizer deposits a drop having a diameter less than about 200 um, 100 um, or 50 um in a volume less than about 1000, 500, 100, 50, or 20 pl. In some cases, the polynucleotide synthesizer deposits between about 1 and 10000, 1 and 5000, 100 and 5000, or 1000 and 5000 droplets per second.

[00122] In some arrangement, during polynucleotide synthesis, the substrate is positioned within and/or sealed within a flow cell. The flow cell may provide continuous or discontinuous flow of liquids such as those comprising reagents necessary for reactions within the substrate, for example, oxidizers and/or solvents. The flow cell may provide continuous or discontinuous flow of a gas, such as nitrogen, for drying the substrate typically through enhanced evaporation of a volatile substrate. A variety of auxiliary devices are useful to improve drying and reduce residual moisture on the surface of the substrate. Examples of such auxiliary drying devices include, without limitation, a vacuum source, depressurizing pump and a vacuum tank. In some cases, a polynucleotide synthesis system comprises one or more flow cells, such as 2, 3, 4, 5, 6, 7, 8, 9, 10, or 20 and one or more substrates, such as 2, 3, 4, 5, 6, 7, 8, 9, 10 or 20. In some cases, a flow cell is configured to hold and provide reagents to the substrate during one or more steps in a synthesis reaction. In some embodiments, a flowcell comprises a lid that slides over the top of a substrate and can be clamped into place to form a pressure tight seal around the edge of the substrate. An adequate seal includes, without limitation, a seal that allows for about 1, 2, 3, 4, 5, 6, 7, 8, 9 or 10

atmospheres of pressure. In some cases, the lid of the flow cell is opened to allow for access to an application device such as a polynucleotide synthesizer. In some cases, one or more steps of a polynucleotide synthesis method are performed on a substrate within a flow cell, without the transport of the substrate.

[00123] In some arrangements, a device for treating a substrate with a fluid comprises a spray bar. Nucleotide monomers may be applied onto a substrate surface then a spray bar sprays the substrate surface with one or more treatment reagents using spray nozzles of the spray bar. In some arrangements, the spray nozzles are sequentially ordered to correlate with different treatment steps during polynucleotide synthesis. The chemicals used in different process steps may be changed in the spray bar to readily accommodate changes in a synthesis method or between steps of a synthesis method. In some embodiments, the spray bar continuously sprays a given chemistry on a surface of a substrate as the substrate moves past the spray bar. In some cases, the spray bar deposits over a wide area of a substrate, much like the spray bars used in lawn sprinklers. In some embodiments, the spray bar nozzles are positioned to provide a uniform coat of treatment material to a given area of a substrate.

[00124] In some embodiments, a polynucleotide synthesis system comprises one or more elements useful for downstream processing of synthesized polynucleotides. As an example, the system comprises a temperature control element such as a thermal cycling device. In some embodiments, the temperature control element is used with a plurality of resolved reactors to perform nucleic acid assembly such as PCA and/or nucleic acid amplification such as PCR.

[00125] De Novo Polynucleotide Synthesis

[00126] Provided herein are systems and methods for synthesis of a high density of polynucleotides on a substrate in a short amount of time. In some instances, the substrate is a flexible substrate. In some instances, at least about 10^{10} , 10^{11} , 10^{12} , 10^{13} , 10^{14} , or 10^{15} bases are synthesized in one day. In some instances, at least about 10×10^8 , 10×10^9 , 10×10^{10} , 10×10^{11} , or 10×10^{12} polynucleotides are synthesized in one day. In some cases, each polynucleotide synthesized comprises at least about 20, 50, 100, 200, 300, 400 or 500 nucleobases. In some cases, these bases are synthesized with a total average error rate of less than about 1 in 100; 200; 300; 400; 500; 1000; 2000; 5000; 10000; 15000; 20000 bases. In some instances, these error rates are for at least 50%, 60%, 70%, 80%, 90%, 95%, 98%, 99%, 99.5%, or more of the polynucleotides synthesized. In some instances, these at least 90%, 95%, 98%, 99%, 99.5%, or more of the polynucleotides synthesized do not differ from a predetermined sequence for which they encode. In some instances, the error rate for synthesized polynucleotides on a substrate using the methods and systems described herein is less than about 1 in 200. In some instances, the error rate for

synthesized polynucleotides on a substrate using the methods and systems described herein is less than about 1 in 1,000. In some instances, the error rate for synthesized polynucleotides on a substrate using the methods and systems described herein is less than about 1 in 2,000. In some instances, the error rate for synthesized polynucleotides on a substrate using the methods and systems described herein is less than about 1 in 3,000. In some instances, the error rate for synthesized polynucleotides on a substrate using the methods and systems described herein is less than about 1 in 5,000. Individual types of error rates include mismatches, deletions, insertions, and/or substitutions for the polynucleotides synthesized on the substrate. The term “error rate” refers to a comparison of the collective amount of synthesized polynucleotide to an aggregate of predetermined polynucleotide sequences. In some instances, synthesized polynucleotides disclosed herein comprise a tether of 12 to 25 bases. In some embodiments, the tether comprises 10, 11, 12, 13, 14, 15, 16, 17, 18, 19, 20, 21, 22, 23, 24, 25, 26, 27, 28, 29, 30, 31, 32, 33, 34, 35, 36, 37, 38, 39, 40, 41, 42, 43, 44, 45, 46, 47, 48, 49, 50 or more bases.

[00127] A suitable method for polynucleotide synthesis on a substrate of this disclosure is a phosphoramidite method comprising the controlled addition of a phosphoramidite building block, i.e. nucleoside phosphoramidite, to a growing polynucleotide chain in a coupling step that forms a phosphite triester linkage between the phosphoramidite building block and a nucleoside bound to the substrate. In some instances, the nucleoside phosphoramidite is provided to the substrate activated. In some instances, the nucleoside phosphoramidite is provided to the substrate with an activator. In some instances, nucleoside phosphoramidites are provided to the substrate in a 1.5, 2, 3, 4, 5, 6, 7, 8, 9, 10, 11, 12, 13, 14, 15, 16, 17, 18, 19, 20, 25, 30, 35, 40, 50, 60, 70, 80, 90, 100-fold excess or more over the substrate-bound nucleosides. In some instances, the addition of nucleoside phosphoramidite is performed in an anhydrous environment, for example, in anhydrous acetonitrile. Following addition and linkage of a nucleoside phosphoramidite in the coupling step, the substrate is optionally washed. In some embodiments, the coupling step is repeated one or more additional times, optionally with a wash step between nucleoside phosphoramidite additions to the substrate. In some instances, a polynucleotide synthesis method used herein comprises 1, 2, 3 or more sequential coupling steps. Prior to coupling, in many cases, the nucleoside bound to the substrate is de-protected by removal of a protecting group, where the protecting group functions to prevent polymerization. A common protecting group is 4,4'-dimethoxytrityl (DMT).

[00128] Following coupling, phosphoramidite polynucleotide synthesis methods optionally comprise a capping step. In a capping step, the growing polynucleotide is treated with a capping agent. A capping step generally serves to block unreacted substrate-bound 5'-OH groups after coupling from further chain elongation, preventing the formation of polynucleotides with internal

base deletions. Further, phosphoramidites activated with 1H-tetrazole often react, to a small extent, with the O6 position of guanosine. Without being bound by theory, upon oxidation with I₂/water, this side product, possibly via O6-N7 migration, undergoes depurination. The apurinic sites can end up being cleaved in the course of the final deprotection of the oligonucleotide thus reducing the yield of the full-length product. The O6 modifications may be removed by treatment with the capping reagent prior to oxidation with I₂/water. In some embodiments, inclusion of a capping step during polynucleotide synthesis decreases the error rate as compared to synthesis without capping. As an example, the capping step comprises treating the substrate-bound polynucleotide with a mixture of acetic anhydride and 1-methylimidazole. Following a capping step, the substrate is optionally washed.

[00129] Following addition of a nucleoside phosphoramidite, and optionally after capping and one or more wash steps, the substrate bound growing nucleic acid may be oxidized. The oxidation step comprises oxidizing the phosphite triester into a tetracoordinated phosphate triester, a protected precursor of the naturally occurring phosphate diester internucleoside linkage. In some instances, oxidation of the growing polynucleotide is achieved by treatment with iodine and water, optionally in the presence of a weak base such as a pyridine, lutidine, or collidine. Oxidation is sometimes carried out under anhydrous conditions using tert-Butyl hydroperoxide or (1S)-(+)-(10-camphorsulfonyl)-oxaziridine (CSO). In some methods, a capping step is performed following oxidation. A second capping step allows for substrate drying, as residual water from oxidation that may persist can inhibit subsequent coupling. Following oxidation, the substrate and growing polynucleotide is optionally washed. In some embodiments, the step of oxidation is substituted with a sulfurization step to obtain oligonucleotide phosphorothioates, wherein any capping steps can be performed after the sulfurization. Many reagents are capable of the efficient sulfur transfer, including, but not limited to, 3-(Dimethylaminomethylidene)amino)-3H-1,2,4-dithiazole-3-thione, DDTT, 3H-1,2-benzodithiol-3-one 1,1-dioxide, also known as Beaucage reagent, and N,N,N'N'-Tetraethylthiuram disulfide (TETD).

[00130] In order for a subsequent cycle of nucleoside incorporation to occur through coupling, a protected 5' end of the substrate bound growing polynucleotide must be removed so that the primary hydroxyl group can react with a next nucleoside phosphoramidite. In some instances, the protecting group is DMT and deblocking occurs with trichloroacetic acid in dichloromethane. Conducting detritylation for an extended time or with stronger than recommended solutions of acids may lead to increased depurination of solid support-bound oligonucleotide and thus reduces the yield of the desired full-length product. Methods and compositions described herein provide for controlled deblocking conditions limiting undesired depurination reactions. In some instances, the

substrate bound polynucleotide is washed after deblocking. In some cases, efficient washing after deblocking contributes to synthesized polynucleotides having a low error rate.

[00131] Methods for the synthesis of polynucleotides on the substrates described herein typically involve an iterating sequence of the following steps: application of a protected monomer to a surface of a substrate feature to link with either the surface, a linker or with a previously deprotected monomer; deprotection of the applied monomer so that it can react with a subsequently applied protected monomer; and application of another protected monomer for linking. One or more intermediate steps include oxidation and/or sulfurization. In some instances, one or more wash steps precede or follow one or all of the steps.

[00132] In some embodiments, polynucleotides are synthesized with photolabile protecting groups, where the hydroxyl groups generated on the surface are blocked by photolabile-protecting groups. When the surface is exposed to UV light, such as through a photolithographic mask, a pattern of free hydroxyl groups on the surface may be generated. These hydroxyl groups can react with photoprotected nucleoside phosphoramidites, according to phosphoramidite chemistry. A second photolithographic mask can be applied and the surface can be exposed to UV light to generate second pattern of hydroxyl groups, followed by coupling with 5'-photoprotected nucleoside phosphoramidite. Likewise, patterns can be generated and oligomer chains can be extended. Without being bound by theory, the lability of a photocleavable group depends on the wavelength and polarity of a solvent employed and the rate of photocleavage may be affected by the duration of exposure and the intensity of light. This method can leverage a number of factors such as accuracy in alignment of the masks, efficiency of removal of photo-protecting groups, and the yields of the phosphoramidite coupling step. Further, unintended leakage of light into neighboring sites can be minimized. The density of synthesized oligomer per spot can be monitored by adjusting loading of the leader nucleoside on the surface of synthesis.

[00133] The surface of the substrate that provides support for polynucleotide synthesis may be chemically modified to allow for the synthesized polynucleotide chain to be cleaved from the surface. In some instances, the polynucleotide chain is cleaved at the same time as the polynucleotide is deprotected. In some cases, the polynucleotide chain is cleaved after the polynucleotide is deprotected. In an exemplary scheme, a trialkoxysilyl amine such as $(\text{CH}_3\text{CH}_2\text{O})_3\text{Si}-(\text{CH}_2)_2-\text{NH}_2$ is reacted with surface SiOH groups of a substrate, followed by reaction with succinic anhydride with the amine to create an amide linkage and a free OH on which the nucleic acid chain growth is supported. Cleavage includes gas cleavage with ammonia or methylamine. In some instances, once released from the surface, polynucleotides are assembled into larger nucleic acids that are sequenced and decoded to extract stored information.

[00134] Assembly

[00135] Polynucleotides may be designed to collectively span a large region of a predetermined sequence that encodes for information. In some instances, larger polynucleotides are generated through ligation reactions to join the synthesized polynucleotides. One example of a ligation reaction is polymerase chain assembly (PCA). In some instances, at least of a portion of the polynucleotides are designed to include an appended region that is a substrate for universal primer binding. For PCA reactions, the presynthesized polynucleotides include overlaps with each other (*e.g.*, 4, 20, 40 or more bases with overlapping sequence). During the polymerase cycles, the polynucleotides anneal to complementary fragments and then are filled in by polymerase. Each cycle thus increases the length of various fragments randomly depending on which polynucleotides find each other. Complementarity amongst the fragments allows for forming a complete large span of double-stranded DNA. In some cases, after the PCA reaction is complete, an error correction step is conducted using mismatch repair detecting enzymes to remove mismatches in the sequence. Once larger fragments of a target sequence are generated, they can be amplified. For example, in some cases, a target sequence comprising 5' and 3' terminal adapter sequences is amplified in a polymerase chain reaction (PCR) which includes modified primers that hybridize to the adapter sequences. In some cases, the modified primers comprise one or more uracil bases. The use of modified primers allows for removal of the primers through enzymatic reactions centered on targeting the modified base and/or gaps left by enzymes which cleave the modified base pair from the fragment. What remains is a double-stranded amplification product that lacks remnants of adapter sequence. In this way, multiple amplification products can be generated in parallel with the same set of primers to generate different fragments of double-stranded DNA.

[00136] Error correction may be performed on synthesized polynucleotides and/or assembled products. An example strategy for error correction involves site-directed mutagenesis by overlap extension PCR to correct errors, which is optionally coupled with two or more rounds of cloning and sequencing. In certain embodiments, double-stranded nucleic acids with mismatches, bulges and small loops, chemically altered bases and/or other heteroduplexes are selectively removed from populations of correctly synthesized nucleic acids. In some embodiments, error correction is performed using proteins/enzymes that recognize and bind to or next to mismatched or unpaired bases within double-stranded nucleic acids to create a single or double-strand break or to initiate a strand transfer transposition event. Non-limiting examples of proteins/enzymes for error correction include endonucleases (T7 Endonuclease I, *E. coli* Endonuclease V, T4 Endonuclease VII, mung bean nuclease, Cell, *E. coli* Endonuclease IV, UVDE), restriction enzymes, glycosylases, ribonucleases, mismatch repair enzymes, resolvases, helicases, ligases, antibodies specific for

mismatches, and their variants. Examples of specific error correction enzymes include T4 endonuclease 7, T7 endonuclease 1, S1, mung bean endonuclease, MutY, MutS, MutH, MutL, cleavase, CELI, and HINF1. In some cases, DNA mismatch-binding protein MutS (*Thermus aquaticus*) is used to remove failure products from a population of synthesized products. In some embodiments, error correction is performed using the enzyme Correctase. In some cases, error correction is performed using SURVEYOR endonuclease (Transgenomic), a mismatch-specific DNA endonuclease that scans for known and unknown mutations and polymorphisms for heteroduplex DNA.

[00137] Release, Extraction and Assembly

[00138] Provided herein are method and devices for replicable information storage. In some instances, multiple copies of the same coding region, the polynucleotide, the same cluster, the same portion of a structure comprising polynucleotides, or the entire structure comprising polynucleotides are synthesized. Where multiple copies of the same polynucleotide are synthesized, each of the polynucleotides may be attached to distinct regions of the surface. The distinct regions may be separated by breaking or cutting. Alternatively, each of the polynucleotides may be present at a locus in the form of a spot, well or channel and individually accessible. For example, contacting the locus with a cleavage reagent and then water would free one copy of the polynucleotide while leaving the other copies intact. Similarly, cleavage of polynucleotides in an entire region or over an entire plate allows for accessing a fraction of a replicate population. Replicate populations may exist in separated reels, plates, belts, and the like. In the case of a flexible material, such as a tape, a replicate region may be cut and the remaining regions of the tape may be spliced back together. Alternatively, nucleic acid information of the synthesized and stored polynucleotides may be obtained by performing amplification of polynucleotides attached to the surface of the structure using primers and a DNA polymerase.

[00139] In some instances, an aqueous or gaseous transfer media is deposited onto one or a plurality of channels in a structure to transfer the polynucleotides from the structure to a receiving unit. For example, a transfer media may pass through a channel in the structure to adhere to, collect and transfer a polynucleotide from a channel in the structure to a receiving unit. In some instance, a charge conducting feature and an applied voltage are employed to attract or repel a transfer media to or through a channel in the structure. In some instances, a slip is employed to direct a transfer media into a channel in the structure. In some cases a pressure release is employed to direct a transfer media into or through a channel in the structure. In some cases a nozzle is employed to form a localized area of high pressure which forces a transfer media into or through a channel in the structure. In some instances, a pin is employed to transfer a polynucleotide from a channel in the

structure to a container to a receiving unit. In such instances, the pin may comprise agents to facilitate transfer media adhesion. In some cases a charge conducting feature is employed to attract or repel a transfer media to or through a channel in a structure, by forming a voltage potential between the conducting feature and the structure. In some cases, a pipette tip, or other capillary flow inducing structure, is used to transfer the fluid and polynucleotides via capillary flow. In some instances, a container comprises one or more compartments that each receives a portion of the transfer media, and the one or more polynucleotides therein, emitted from a single respective channel. In some instances, the container comprises a single compartment that receives one or more portions of the transfer media, each containing one or more polynucleotides therein, emitted from a one or more structure channels.

[00140] Referring to **FIGS. 14A** and **14B**, a polynucleotide **1417** is transferred from a channel **1415** in a structure **1405** through the deposition of an aqueous or gaseous transfer media **1419**, which adheres to a polynucleotide **1417**, and wherein one or more interconnected conductor plates **1420** and a power unit **1422** direct the transfer media **1419** to the one or more channels respectively. In this arrangement, a series of one or more interconnected conductor plates **1420** are each located above, and surround, the proximal edge a respective channel **1415**, and wherein a voltage potential imparted by a power unit **1422** between the interconnected conductor plates **1420** and the structure **1405**, attracts the transfer media **1419** to the proximal opening of one or more channels **1415**. As such, an exemplary method of attracting the transfer media **1419** to the proximal opening of the one or more channels **1415** in this instance comprises: depositing a transfer media **1419** into a main channel **1410** of a structure **1405**, and applying a voltage potential between the interconnected conductor plates **1420** and the structure **1405**, via a power unit **1422**. Further, in this case, the transfer media **1419** may contain a positive or negative charge which reacts to an electrostatic or magnetic field or a potential difference created by the power unit **1422**, as it passes through the structure **1405** and the channels **1415**. Additionally, the electrostatic properties of the one or more conductor plates **1420** and the structure **1405** can be tuned to optimize the transfer of the polynucleotide **1417** within the transfer media **1419** through a channel **1415** in the structure. Finally, a nonconductive separator may be positioned between the structure **1405** and the one or more conductor plates **1420**, to tune or optimize the electrostatic or magnetic field or the potential difference formed therein. Further, this case may additionally employ hydrophilic or hydrophobic structures on one or more faces of the main channel **1410** or on the interconnected conductor plates **1420** to more efficiently direct the transfer media **1419** into the channels **1415**.

[00141] Referring to **FIGS. 15A** and **15B**, a polynucleotide **1517** is transferred from a channel **1515** in a structure **1505**, through the deposition of an aqueous or gaseous transfer media **1519**

which adheres to one or more polynucleotides **1517**, and wherein the transfer media **1519** is attracted through the one or more channels **1515** by one or more conducting sheets **1524** and a power unit **1522**. In this arrangement, a conducting sheet **1524** below and surrounding the distal edge of a channel **1515**, and a power unit **1522**, are employed to attract the transfer media **1519** from the proximal opening of a channel **1515**, see **FIG. 15A**, to the distal opening of that channel **1515**, see **FIG. 15B**. As such, an exemplary method of attracting the transfer media **1519** to the distal opening of a channel **1515** in this instance comprises: applying a voltage potential between a conducting sheet **1524** and the structure **1505**, via a power unit **1522**. Further, in this case, the transfer media **1519** may contain a positive or negative charge which reacts to an electrostatic or magnetic field or a potential difference created by the power unit **1522**, as it passes through the structure **1505**, and the one or more conducting sheets **1524**. Additionally, the electrostatic properties of the one or more conducting sheets **1524** and the structure **1505** can be tuned to optimize the transfer of the polynucleotides **1517** in the transfer media **1519** through a channel **1515** in the structure **1505**. A nonconductive separator may be positioned between the structure **1505** and the one or more conducting sheets **1524**, to tune or optimize the electrostatic or magnetic field or the potential difference formed therein.

[00142] Referring to **FIGS. 16A** and **16B**, a polynucleotide **1617** is transferred from a channel **1615** in a structure **1605**, through the deposition of an aqueous or gaseous transfer media **1619** which adheres to a polynucleotide **1617**, and wherein a slip **1630**, in flush contact with the surface of, and positioned at an acute angle of attack **1632** relative to, a stationary plate structure **1605** or a moving non-continuous flexible structure, is employed to direct a transfer media into to the channels of the structure. In this arrangement, a slip **1630** is employed to direct the transfer media **1619** from the proximal opening of the one or more channels **1615**, see **FIG. 16A**, to the distal opening of the respective channel **1615**, see **FIG. 16B**. As such, an exemplary method of directing the transfer media **1619** through one or more channels **1615** in this instance comprises: translating or rotating the one or more slips **1630** relative to the structure **1605**. In these instances the acute angle of attack **1632** may be equal to about 10°, 20°, 30°, 40°, 50°, 60°, 70° or about 80°. In some cases, a single slip **1630** or a rigid assembly of one or more slips **1630** is employed to direct the transfer media **1619** through the one or more channels **1615**. In some cases, the relative velocity between the slip **1630** and the structure **1605** is up to about 1 centimeter/second. In some cases, the relative velocity between the slip **1630** and the structure **1605** is more than 1 centimeter/second. In some cases, the relative angular velocity between the slip **1630** relative to the structure **1605** is up to about 1 rotation/second. In some cases, the relative angular velocity between the slip **1630** and the structure **1605** is more than 1 rotation/second. In some cases, the slip **1630** can contort to

partially enter the channel **1615**. Finally, in this instance, the slip **1630** may be composed of any waterproof material comprising plastic, rubber, wood, metal, glass, fiberglass, carbon fiber or any combination thereof.

[00143] The case wherein a polynucleotide **1717** is transferred from a channel **1715** in a structure **1705**, through the deposition of an aqueous or gaseous transfer media **1719** which adheres to a polynucleotide **1717**, and wherein an applied pressure **1740** within a gas or fluid, and a pressure release **1742** are employed to force the transfer media **1719** through a channel **1715** in the structure **1705**, is displayed in **FIGS. 17A** and **17B**. In this instance, a pressure release **1742** block the applied pressure **1740**, thus forming a pressure differential between distal edge a channel **1715**, and the distal face a pressure release **1742**, see **FIG. 17A**, which, when released by the opening of a pressure release **1742**, forces the transfer media **1719** through a channel, see **FIG. 17B**. In some cases, a single pressure release **1742** is employed to direct the transfer media **1719** through one or more channels **1715** at once. As such, an exemplary method of directing the transfer media **1719** through a channel **1715** in this instance comprises: forming an applied pressure **1740** within the gas or fluid, and translating or rotating a pressure release **1742** relative to the structure **1705**. In some cases, the relative velocity between the one or more pressure releases **1742** and the structure **705** is up to about 1 centimeter/second. In some cases, the relative velocity between the one or more pressure releases **1742** and the structure **1705** is more than 1 centimeter/second. In some arrangements, the relative rotational velocity between the one or more pressure releases **1742** and the structure **1705** is up to about 1 rotation/second. In some cases, the relative rotational velocity between the one or more pressure releases **1742** and the structure **1705** is more than 1 rotation/second. In some instances the pressure differential within the gas or fluid surrounding the structure **1705**, created by the applied pressure **1740** is less than 1 atm. In some instances the pressure differential within the gas or fluid surrounding the structure **1705**, created by the applied pressure **1740** is more than 1 atm.

[00144] Referring to **FIG. 18**, a polynucleotide **1817** is transferred from a channel **1815** in a moving non-continuous flexible structure **1807**, through the deposition of an aqueous or gaseous transfer media **1819** which adheres a polynucleotide **1817**, and wherein a nozzle **1844** and an applied pressure **1840**, are employed to force a transfer media **1819** through a channel **1815** in the structure **1807**. As such, an exemplary method of directing the transfer media **1819** through a channel **1815** in this instance comprises: translating the continuous flexible structure **1807**, about a roller **1803** such that a channel **1815** is aligned below a nozzle **1844**, and triggering a nozzle **1844** to direct an applied pressure **1840** towards a channel **1815**. In some instances, the pressure differential within the gas or fluid surrounding the structure **1807** imparted by a nozzle **1844** is less

than 1 atm. In some instances the pressure differential within the gas or fluid surrounding the structure 1807 imparted by a nozzle 1844 is more than 1 atm.

[00145] Referring to FIGS. 19A and 19B, a polynucleotide 1917 is transferred from a channel 1915 in a structure 1905, through the deposition of an aqueous or gaseous transfer media 1919, and wherein a pin 1950 adheres to the transfer media 1919, and a polynucleotide 1917 within, to remove the transfer media 1919 from a channel 1915 in the structure 1905 is shown in FIGS. 19A and 19B. In this instance, the pin 1950 contacts and attracts the transfer media 1919, see FIG. 19A, wherein the attraction of the transfer media 1919 to the pin 1950 is greater than the transfer media's 1919 attraction to the distal edge of a channel 1915, and wherein a relative vertical motion between the pin 1950 and the structure 1905 dislocates the transfer media 1919 from the structure 1905, see FIG. 19B. In such instances, the pin 1950 may comprise features to facilitate transfer media adhesion comprising hydrophilic or gas-philic structures or coatings, or a binding chemical coating. In some instances, the pin 1950 is comprised of any hard material comprising metal, plastic, rubber, carbon fiber, wood, fiberglass or any combination thereof. In other instances, the pin 1950 is comprised of a conductive material capable of conducting an electric, electrostatic or magnetic charge or field to attract the transfer media 1919. In some cases, the relative velocity between the pin 1950 and the structure 1905 is up to about 1 centimeter/second. In some cases, the relative velocity between the pin 1950 and the structure 1905 is more than 1 centimeter/second.

[00146] Referring to FIGS. 20A and 20B, a polynucleotide 2017 is transferred from a channel 2015 in a structure 2005 through the deposition of an aqueous or gaseous transfer media 2019, and wherein the transfer media 2019 is repelled from a channel in the structure 2005 to a receiving unit 2060, by a voltage applied from a power unit 2022 to a conducting sheet 2024. In this instance, a conducting sheet 2024 below and surrounding the distal edge of a channel 2015, and a power unit 2022 are employed to repel the transfer media 2019 from the distal opening of a channel 2015, see FIG. 20A, to a receiving unit 2060, see FIG. 20B. As such, an exemplary method of repelling the transfer media 2019 from the distal opening of one or more channels 2015 in this instance comprises: applying a voltage potential between the one or more conducting sheets 2024 and the structure 2005, via a power unit 2022. Further, in this case, the transfer media 2019 may contain a positive or negative charge which reacts to an electrostatic or magnetic field or a potential difference created by the power unit 2022, as it passes through the structure 2005, and a sheet 2024. Additionally, the electrostatic properties of the one or more conducting sheets 2024 and the structure 2005 can be tuned to optimize the transfer of the polynucleotide 2017 in the transfer media 2019 through a channel 2015 in the structure. Finally, a nonconductive separator may be

positioned between the structure **2005** and a conducting sheet **2024**, to tune or optimize the electrostatic or magnetic field or the potential difference formed therein.

[00147] In some arrangements, a combination of means for attracting the transfer media to or from the channels employ a fluid or gas transfer mechanisms including but not limited to: to laminar pressure, capillary pressure, slip flow pressure, magnetic force, electrostatic force, peristaltic force, sound waves, vibrational force, centripetal force, centrifugal force, or any combination thereof.

[00148] In some instance, see *e.g.*, **FIG. 21** the receiving unit **2160** comprises two or more compartments **2162a 2162b**, wherein each compartment **2162a 2162b** is capable of receiving and temporarily storing a single respective portion of a gaseous or fluidic transfer media **2119** comprising a polynucleotide **2117**. In other arrangements, see *e.g.*, **FIG. 22** the receiving unit **2260** comprises a single compartment **2262**, capable of receiving and temporarily storing one or more portions of a gaseous or fluidic transfer media **2219**, comprising a polynucleotide **2217**.

[00149] Sequencing

[00150] After extraction and/or amplification of polynucleotides from the surface of the structure, suitable sequencing technology may be employed to sequence the polynucleotides. In some cases, the DNA sequence is read on the substrate or within a feature of a structure. In some cases, the polynucleotides stored on the substrate are extracted is optionally assembled into longer nucleic acids and then sequenced.

[00151] Polynucleotides synthesized and stored on the structures described herein encode data that can be interpreted by reading the sequence of the synthesized polynucleotides and converting the sequence into binary code readable by a computer. In some cases the sequences require assembly, and the assembly step may need to be at the nucleic acid sequence stage or at the digital sequence stage.

[00152] Provided herein are detection systems comprising a device capable of sequencing stored polynucleotides, either directly on the structure and/or after removal from the main structure. In cases where the structure is a reel-to-reel tape of flexible material, the detection system comprises a device for holding and advancing the structure through a detection location and a detector disposed proximate the detection location for detecting a signal originated from a section of the tape when the section is at the detection location. In some instances, the signal is indicative of a presence of a polynucleotide. In some embodiments, the signal is indicative of a sequence of a polynucleotide (*e.g.*, a fluorescent signal). In some instances, information encoded within polynucleotides on a continuous tape is read by a computer as the tape is conveyed continuously through a detector operably connected to the computer. In some instances, a detection system comprises a computer system comprising a polynucleotide sequencing device, a database for storage and retrieval of data

relating to polynucleotide sequence, software for converting DNA code of a polynucleotide sequence to binary code, a computer for reading the binary code, or any combination thereof.

Computer Systems

[00153] In various aspects, any of the systems described herein are operably linked to a computer and are optionally automated through a computer either locally or remotely. In various embodiments, the methods and systems of the invention further comprise software programs on computer systems and use thereof. Accordingly, computerized control for the synchronization of the dispense/vacuum/refill functions such as orchestrating and synchronizing the material deposition device movement, dispense action and vacuum actuation are within the bounds of the invention. In some instances, the computer systems are programmed to interface between the user specified base sequence and the position of a material deposition device to deliver the correct reagents to specified regions of the substrate.

[00154] The computer system **2300** illustrated in **FIG. 23** may be understood as a logical apparatus that can read instructions from media **2311** and/or a network port **2305**, which can optionally be connected to server **2309** having fixed media **412**. The system, such as shown in Figure 4 can include a CPU **2301**, disk drives **2303**, optional input devices such as keyboard **2315** and/or mouse **2316** and optional monitor **2307**. Data communication can be achieved through the indicated communication medium to a server at a local or a remote location. The communication medium can include any means of transmitting and/or receiving data. For example, the communication medium can be a network connection, a wireless connection or an internet connection. Such a connection can provide for communication over the World Wide Web. It is envisioned that data relating to the present disclosure can be transmitted over such networks or connections for reception and/or review by a party **2322**.

[00155] **FIG. 24** is a block diagram illustrating a first example architecture of a computer system **1500** that can be used in connection with example embodiments of the present invention. As depicted in Figure 5, the example computer system can include a processor **2402** for processing instructions. Non-limiting examples of processors include: Intel Xeon™ processor, AMD Opteron™ processor, Samsung 32-bit RISC ARM 1176JZ(F)-S v1.0™ processor, ARM Cortex-A8 Samsung S5PC100™ processor, ARM Cortex-A8 Apple A4™ processor, Marvell PXA 930™ processor, or a functionally-equivalent processor. Multiple threads of execution can be used for parallel processing. In some embodiments, multiple processors or processors with multiple cores can also be used, whether in a single computer system, in a cluster, or distributed across systems over a network comprising a plurality of computers, cell phones, and/or personal data assistant devices.

[00156] As illustrated in FIG. 24, a high speed cache 2404 can be connected to, or incorporated in, the processor 2402 to provide a high speed memory for instructions or data that have been recently, or are frequently, used by processor 2402. The processor 502 is connected to a north bridge 2406 by a processor bus 2408. The north bridge 506 is connected to random access memory (RAM) 2410 by a memory bus 2412 and manages access to the RAM 2410 by the processor 2402. The north bridge 2406 is also connected to a south bridge 2414 by a chipset bus 2416. The south bridge 2414 is, in turn, connected to a peripheral bus 2418. The peripheral bus can be, for example, PCI, PCI-X, PCI Express, or other peripheral bus. The north bridge and south bridge are often referred to as a processor chipset and manage data transfer between the processor, RAM, and peripheral components on the peripheral bus 2418. In some alternative architectures, the functionality of the north bridge can be incorporated into the processor instead of using a separate north bridge chip.

[00157] In some embodiments, system 2400 can include an accelerator card 2422 attached to the peripheral bus 2418. The accelerator can include field programmable gate arrays (FPGAs) or other hardware for accelerating certain processing. For example, an accelerator can be used for adaptive data restructuring or to evaluate algebraic expressions used in extended set processing.

[00158] Software and data are stored in external storage 2424 and can be loaded into RAM 2410 and/or cache 2404 for use by the processor. The system 2400 includes an operating system for managing system resources; non-limiting examples of operating systems include: Linux, Windows™, MACOS™, BlackBerry OS™, iOS™, and other functionally-equivalent operating systems, as well as application software running on top of the operating system for managing data storage and optimization in accordance with example embodiments of the present invention.

[00159] In this example, system 2400 also includes network interface cards (NICs) 2420 and 521 connected to the peripheral bus for providing network interfaces to external storage, such as Network Attached Storage (NAS) and other computer systems that can be used for distributed parallel processing.

[00160] FIG. 25 is a diagram showing a network 2500 with a plurality of computer systems 602a, and 602b, a plurality of cell phones and personal data assistants 2002c, and Network Attached Storage (NAS) 2504a, and 2504b. In example embodiments, systems 2502a, 2502b, and 2502c can manage data storage and optimize data access for data stored in Network Attached Storage (NAS) 2504a and 2504b. A mathematical model can be used for the data and be evaluated using distributed parallel processing across computer systems 2502a, and 2502b, and cell phone and personal data assistant systems 2502c. Computer systems 2502a, and 2502b, and cell phone and

personal data assistant systems **2502c** can also provide parallel processing for adaptive data restructuring of the data stored in Network Attached Storage (NAS) **2504a** and **2504b**. **FIG. 25** illustrates an example only, and a wide variety of other computer architectures and systems can be used in conjunction with the various embodiments of the present invention. For example, a blade server can be used to provide parallel processing. Processor blades can be connected through a back plane to provide parallel processing. Storage can also be connected to the back plane or as Network Attached Storage (NAS) through a separate network interface.

[00161] In some example embodiments, processors can maintain separate memory spaces and transmit data through network interfaces, back plane or other connectors for parallel processing by other processors. In other embodiments, some or all of the processors can use a shared virtual address memory space.

[00162] **FIG. 26** is a block diagram of a multiprocessor computer system **2600** using a shared virtual address memory space in accordance with an example embodiment. The system includes a plurality of processors **2602a-f** that can access a shared memory subsystem **2604**. The system incorporates a plurality of programmable hardware memory algorithm processors (MAPs) **2606a-f** in the memory subsystem **2604**. Each MAP **2606a-f** can comprise a memory **2608a-f** and one or more field programmable gate arrays (FPGAs) **2610a-f**. The MAP provides a configurable functional unit and particular algorithms or portions of algorithms can be provided to the FPGAs **2610a-f** for processing in close coordination with a respective processor. For example, the MAPs can be used to evaluate algebraic expressions regarding the data model and to perform adaptive data restructuring in example embodiments. In this example, each MAP is globally accessible by all of the processors for these purposes. In one configuration, each MAP can use Direct Memory Access (DMA) to access an associated memory **2608a-f**, allowing it to execute tasks independently of, and asynchronously from, the respective microprocessor **2602a-f**. In this configuration, a MAP can feed results directly to another MAP for pipelining and parallel execution of algorithms.

[00163] The above computer architectures and systems are examples only, and a wide variety of other computer, cell phone, and personal data assistant architectures and systems can be used in connection with example embodiments, including systems using any combination of general processors, co-processors, FPGAs and other programmable logic devices, system on chips (SOCs), application specific integrated circuits (ASICs), and other processing and logic elements. In some embodiments, all or part of the computer system can be implemented in software or hardware. Any variety of data storage media can be used in connection with example embodiments, including random access memory, hard drives, flash memory, tape drives, disk arrays, Network Attached Storage (NAS) and other local or distributed data storage devices and systems.

[00164] In example embodiments, the computer system can be implemented using software modules executing on any of the above or other computer architectures and systems. In other embodiments, the functions of the system can be implemented partially or completely in firmware, programmable logic devices such as field programmable gate arrays (FPGAs) as referenced in Figure 7, system on chips (SOCs), application specific integrated circuits (ASICs), or other processing and logic elements. For example, the Set Processor and Optimizer can be implemented with hardware acceleration through the use of a hardware accelerator card, such as the accelerator card **1822** illustrated in **FIG. 18**.

[00165] Provided herein are methods for storing information, comprising: converting an item of information in the form of at least one digital sequence to at least one nucleic acid sequence; providing a flexible structure having a surface; synthesizing a plurality of polynucleotides having predetermined sequences collectively encoding for the at least one nucleic acid sequence, wherein the plurality of polynucleotides comprises at least about 100,000 polynucleotides, and wherein the plurality of polynucleotides extends from the surface of the flexible structure; and storing the plurality of polynucleotides. Further provided herein are methods wherein synthesizing comprises: depositing nucleosides on the surface at predetermined locations; and moving least a portion of the flexible structure through a bath or emissions from a spray bar. Further provided herein are methods wherein the bath or emissions from a spray bar expose the surface of the structure to an oxidizing reagent or a deblocking reagent. Further provided herein are methods wherein synthesizing further comprises capping the nucleosides deposited on the surface. Further provided herein are methods wherein the nucleosides comprise a nucleoside phosphoramidite. Further provided herein are methods wherein the flexible structure comprises a reel-to-reel tape or a continuous tape. Further provided herein are methods wherein the flexible structure comprises a thermoplastic material. Further provided herein are methods wherein the thermoplastic material comprises a polyaryletherketone. Further provided herein are methods wherein the polyaryletherketone is polyetherketone, polyetherketoneketone, poly(ether ether ketone ketone), polyether ether ketone or polyetherketoneetherketoneketone. Further provided herein are methods wherein the flexible structure comprises nylon, nitrocellulose, polypropylene, polycarbonate, polyethylene, polyurethane, polystyrene, acetal, acrylic, acrylonitrile, butadiene styrene, polyethylene terephthalate, polymethyl methacrylate, polyvinyl chloride, transparent PVC foil, Poly(methyl methacrylate), styrenic polymer, fluorine-containing polymers, polyethersulfone or polyimide. Further provided herein are methods wherein each polynucleotide of the plurality of polynucleotides comprises from 50 to 500 bases in length. Further provided herein are methods wherein the plurality of polynucleotides comprises at least about 10 billion polynucleotides. Further

provided herein are methods wherein at least about 1.75×10^{13} nucleobases are synthesized within 24 hours. Further provided herein are methods wherein at least about 262.5×10^9 polynucleotides are synthesized within 72 hours. Further provided herein are methods wherein the item of information is text information, audio information or visual information. Further provided herein are methods wherein the nucleosides comprise nucleoside phosphoramidite.

[00166] Provided herein are methods for storing information, comprising: converting an item of information in the form of at least one digital sequence to at least one nucleic acid sequence; providing a structure having a surface; synthesizing a plurality of polynucleotides having predetermined sequences collectively encoding for the at least one nucleic acid sequence, wherein the plurality of polynucleotides comprises at least about 100,000 polynucleotides, wherein the plurality of polynucleotides extends from the surface of the structure, and wherein synthesizing comprises: cleaning a surface of the structure; depositing nucleosides on the surface at predetermined locations; oxidizing, deblocking, and optionally capping the nucleosides deposited on the surface; wherein the cleaning, oxidizing, deblocking, and capping comprises moving at least a portion of the flexible structure through a bath or emissions from a spray bar; and storing the plurality of polynucleotides. Further provided herein are methods wherein the nucleosides comprise nucleoside phosphoramidite.

[00167] Provided herein are methods for storing information, comprising: converting an item of information in the form of at least one digital sequence to at least one nucleic acid sequence; synthesizing a plurality of polynucleotides having predetermined sequences collectively encoding for the at least one nucleic acid sequence, wherein the plurality of polynucleotides comprises at least about 10,000 polynucleotides, wherein the plurality of polynucleotides collectively encode for a sequence that differs from the predetermined sequences by no more than 1 base in 1000, and wherein each polynucleotide of the plurality of polynucleotides comprises from 50 to 500 bases in length; and storing the at least about 10,000 polynucleotides. Further provided herein are methods wherein the plurality of polynucleotides comprises at least about 100,000 polynucleotides. Further provided herein are methods wherein the plurality of polynucleotides comprises at least about 1,000,000 polynucleotides. Further provided herein are methods wherein the plurality of polynucleotides comprises at least about 10 billion polynucleotides. Further provided herein are methods wherein greater than 90% of the polynucleotides encode for a sequence that does not differ from the predetermined sequence. Further provided herein are methods wherein the item of information is text information, audio information or visual information. Further provided herein are methods wherein the structure is rigid or flexible, and wherein the structure comprises a

surface, and wherein the plurality of polynucleotides extend from the surface. Further provided herein are methods wherein the nucleosides comprise nucleoside phosphoramidite.

[00168] Provided herein are methods for storing information, comprising: converting an item of information in the form of at least one digital sequence to at least one nucleic acid sequence; synthesizing a plurality of polynucleotides having predetermined sequences collectively encoding for the at least one nucleic acid sequence, wherein the plurality of polynucleotides comprises at least about 10,000 polynucleotides, wherein each polynucleotide of the plurality of polynucleotides comprises from 50 to 500 bases in length, and where the plurality of polynucleotides extends from the surface of a flexible structure; and storing the plurality of polynucleotides. Further provided herein are methods wherein the flexible structure comprises a reel-to-reel tape or a continuous tape. Further provided herein are methods wherein each polynucleotide extends from a locus on the surface of the flexible structure, wherein the locus is about 1 μm to about 500 μm in diameter. Further provided herein are methods wherein the locus is about 1 μm to about 50 μm in diameter. Further provided herein are methods wherein the locus is about 10 μm in diameter. Further provided herein are methods wherein the flexible structure comprises a thermoplastic material. Further provided herein are methods wherein the thermoplastic material comprises a polyaryletherketone. Further provided herein are methods wherein the polyaryletherketone is polyetherketone, polyetherketoneketone, poly(ether ether ketone ketone), polyether ether ketone or polyetherketoneetherketoneketone. Further provided herein are methods wherein the flexible structure comprises nylon, nitrocellulose, polypropylene, polycarbonate, polyethylene, polyurethane, polystyrene, acetal, acrylic, acrylonitrile, butadiene styrene, polyethylene terephthalate, polymethyl methacrylate, polyvinyl chloride, transparent PVC foil, Poly(methyl methacrylate), styrenic polymer, fluorine-containing polymers, polyethersulfone or polyimide. Further provided herein are methods wherein the flexible structure has a thickness of less than about 10 mm. Further provided herein are methods wherein each polynucleotide is about 200 bases in length. Further provided herein are methods wherein at least about 1.75×10^{13} nucleobases are synthesized within 24 hours. Further provided herein are methods wherein at least about 262.5×10^9 polynucleotides are synthesized within 72 hours. Further provided herein are methods wherein the nucleosides comprise nucleoside phosphoramidite.

[00169] Provided herein are methods for storing information, the method comprising: encrypting at least one item of information in the form of at least one digital sequence to at least one nucleic acid sequence; synthesizing a plurality of polynucleotides having predetermined sequences collectively encoding for the at least one nucleic acid sequence, wherein the plurality of polynucleotides comprises at least about 10,000 polynucleotides, and wherein each polynucleotide

of the plurality of polynucleotides comprises from 50 to 500 bases in length; storing the plurality of polynucleotides; sequencing the plurality of polynucleotides; decrypting the plurality of polynucleotides from a nucleic acid sequence to a digital sequence; and assembling the digital sequence to form the at least one digital sequence, wherein the at least one digital sequence is assembled with 100% accuracy compared to the initial at least one digital sequence. Further provided herein are methods further comprising releasing the plurality of polynucleotides. Further provided herein are methods wherein the nucleosides comprise nucleoside phosphoramidite.

[00170] Provided herein are devices for information storage, comprising: a flexible structure having a surface; and a plurality of loci on the surface, wherein each locus has a width of from about 1 to about 500 μm , and wherein each locus of the plurality of loci is coated with a moiety that binds to the surface and comprises a hydroxyl group available for nucleoside coupling. Further provided herein are devices wherein the flexible structure rests in a curved position. Further provided herein are devices wherein the curved position comprises a curve that is greater than 30 degrees. Further provided herein are devices wherein the curved position comprises a curve that is greater than 180 degrees. Further provided herein are devices wherein the flexible structure comprises at least about 1 million loci. Further provided herein are devices wherein the flexible structure has a total surface area of less than about 4.5 m^2 . Further provided herein are devices wherein the flexible structure comprises more than 2 billion loci per m^2 . Further provided herein are devices wherein the flexible structure comprises a thermoplastic material. Further provided herein are devices wherein the thermoplastic material comprises a polyaryletherketone. Further provided herein are devices wherein the polyaryletherketone is polyetherketone, polyetherketoneketone, poly(ether ether ketone ketone), polyether ether ketone or polyetherketoneetherketoneketone. Further provided herein are devices wherein the flexible structure comprises nylon, nitrocellulose, polypropylene, polycarbonate, polyethylene, polyurethane, polystyrene, acetal, acrylic, acrylonitrile, butadiene styrene, polyethylene terephthalate, polymethyl methacrylate, polyvinyl chloride, transparent PVC foil, Poly(methyl methacrylate), styrenic polymer, fluorine-containing polymers, polyethersulfone or polyimide. Further provided herein are devices wherein the flexible structure has a thickness of less than about 10 mm. Further provided herein are devices wherein each locus is from about 1 μm to about 50 μm in width. Further provided herein are devices wherein each locus has a diameter of about 10 μm . Further provided herein are devices wherein the center of a first locus is about 21 μm from the center of a second locus and the first locus and the second locus. Further provided herein are devices wherein the flexible structure comprises a reel-to-reel tape or a continuous tape. Further provided herein are devices wherein each locus comprises a channel.

[00171] Provided herein are polynucleotide libraries for information storage, comprising a plurality of polynucleotides, wherein the plurality of polynucleotides comprises at least about 10,000 polynucleotides, wherein the plurality of polynucleotides collectively encodes for a sequence that differs from an aggregate of predetermined sequences by no more than 1 base in 1000, and wherein each polynucleotide of the plurality of polynucleotides comprises: a predetermined sequence that, when decrypted, encodes for digital information. Further provided herein are libraries wherein the plurality of polynucleotides comprises at least about 100,000 polynucleotides. Further provided herein are libraries wherein the plurality of polynucleotides comprises at least about 10 billion polynucleotides. Further provided herein are libraries wherein each polynucleotide of the plurality of polynucleotides is attached to a surface of a structure by a tether. Further provided herein are libraries wherein the tether comprises a cleavable region having at least one nucleotide chemically modified to detach from the polynucleotide in the presence of a cleaving reagent. Further provided herein are libraries wherein the tether comprises from about 10 to about 50 bases. Further provided herein are libraries wherein greater than 90% of the polynucleotides encode for a sequence that does not differ from the predetermined sequences. Further provided herein are libraries wherein the digital information encodes for text, audio or visual information. Further provided herein are libraries wherein the library is synthesized in less than 3 days. Further provided herein are libraries wherein the library is synthesized in less than 24 hours.

[00172] Further provided herein are methods for synthesizing polynucleotides that encode a range of an amount of digital information. In some instances, an amount of digital information is at least 1 gigabyte (GB). In some instances, the amount of digital information is at least 1, 2, 3, 4, 5, 6, 7, 8, 9, 10, 20, 50, 100, 200, 300, 400, 500, 600, 700, 800, 900, 1000 or more than 1000 gigabytes. In some instances, the amount of digital information is at least 1 terabyte (TB). In some instances, the amount of digital information is at least 1, 2, 3, 4, 5, 6, 7, 8, 9, 10, 20, 50, 100, 200, 300, 400, 500, 600, 700, 800, 900, 1000 or more than 1000 terabytes. In some instances, the amount of digital information is at least 1 petabyte (PB). In some instances, the amount of digital information is at least 1, 2, 3, 4, 5, 6, 7, 8, 9, 10, 20, 50, 100, 200, 300, 400, 500, 600, 700, 800, 900, 1000 or more than 1000 petabytes.

[00173] The following examples are set forth to illustrate more clearly the principle and practice of embodiments disclosed herein to those skilled in the art and are not to be construed as limiting the scope of any claimed embodiments. Unless otherwise stated, all parts and percentages are on a weight basis.

EXAMPLES

[00174] EXAMPLE 1: Functionalization of a device surface

[00175] A device was functionalized to support the attachment and synthesis of a library of polynucleotides. The device surface was first wet cleaned using a piranha solution comprising 90% H₂SO₄ and 10% H₂O₂ for 20 minutes. The device was rinsed in several beakers with DI water, held under a DI water gooseneck faucet for 5 min, and dried with N₂. The device was subsequently soaked in NH₄OH (1:100; 3 mL:300 mL) for 5 min, rinsed with DI water using a handgun, soaked in three successive beakers with DI water for 1 min each, and then rinsed again with DI water using the handgun. The device was then plasma cleaned by exposing the device surface to O₂. A SAMCO PC-300 instrument was used to plasma etch O₂ at 250 watts for 1 min in downstream mode.

[00176] The cleaned device surface was actively functionalized with a solution comprising N-(3-triethoxysilylpropyl)-4-hydroxybutyramide using a YES-1224P vapor deposition oven system with the following parameters: 0.5 to 1 torr, 60 min, 70 °C, 135 °C vaporizer. The device surface was resist coated using a Brewer Science 200X spin coater. SPR™ 3612 photoresist was spin coated on the device at 2500 rpm for 40 sec. The device was pre-baked for 30 min at 90 °C on a Brewer hot plate. The device was subjected to photolithography using a Karl Suss MA6 mask aligner instrument. The device was exposed for 2.2 sec and developed for 1 min in MSF 26A. Remaining developer was rinsed with the handgun and the device soaked in water for 5 min. The device was baked for 30 min at 100 °C in the oven, followed by visual inspection for lithography defects using a Nikon L200. A descum process was used to remove residual resist using the SAMCO PC-300 instrument to O₂ plasma etch at 250 watts for 1 min.

[00177] The device surface was passively functionalized with a 100 µL solution of perfluorooctyltrichlorosilane mixed with 10 µL light mineral oil. The device was placed in a chamber, pumped for 10 min, and then the valve was closed to the pump and left to stand for 10 min. The chamber was vented to air. The device was resist stripped by performing two soaks for 5 min in 500 mL NMP at 70 °C with ultrasonication at maximum power (9 on Crest system). The device was then soaked for 5 min in 500 mL isopropanol at room temperature with ultrasonication at maximum power. The device was dipped in 300 mL of 200 proof ethanol and blown dry with N₂. The functionalized surface was activated to serve as a support for polynucleotide synthesis.

[00178] EXAMPLE 2: Synthesis of a 50-mer sequence oligonucleotides

[00179] A two dimensional oligonucleotide synthesis device was assembled into a flowcell, which was connected to a flowcell (Applied Biosystems (ABI394 DNA Synthesizer"). The two-dimensional oligonucleotide synthesis device was uniformly functionalized with N-(3-TRIETHOXSILYLPROPYL)-4-HYDROXYBUTYRAMIDE (Gelest) was used to synthesize an

exemplary oligonucleotide of 50 bp ("50-mer oligonucleotide") using oligonucleotide synthesis methods described herein.

[00180] The sequence of the 50-mer was as described in SEQ ID NO.: 1.

5'AGACAATCAACCATTTGGGGTGGACAGCCTTGACCTCTAGACTTCGGCAT##TTTTTTT TTT3' (SEQ ID NO.: 1), where # denotes Thymidine-succinyl hexamide CED phosphoramidite (CLP-2244 from ChemGenes), which is a cleavable linker enabling the release of polynucleotides from the surface during deprotection.

[00181] The synthesis was done using standard DNA synthesis chemistry (coupling, capping, oxidation, and deblocking) according to the protocol in **Table 3** and an ABI synthesizer.

Table 3:

Table 3		
General DNA Synthesis Process Name	Process Step	Time (sec)
WASH (Acetonitrile Wash Flow)	Acetonitrile System Flush	4
	Acetonitrile to Flowcell	23
	N2 System Flush	4
	Acetonitrile System Flush	4
DNA BASE ADDITION (Phosphoramidite + Activator Flow)	Activator Manifold Flush	2
	Activator to Flowcell	6
	Activator + Phosphoramidite to Flowcell	6
	Activator to Flowcell	0.5
	Activator + Phosphoramidite to Flowcell	5
	Activator to Flowcell	0.5
	Activator + Phosphoramidite to Flowcell	5
	Activator to Flowcell	0.5
	Activator + Phosphoramidite to Flowcell	5
	Incubate for 25sec	25
WASH (Acetonitrile Wash Flow)	Acetonitrile System Flush	4
	Acetonitrile to Flowcell	15
	N2 System Flush	4
	Acetonitrile System Flush	4
DNA BASE ADDITION (Phosphoramidite + Activator Flow)	Activator Manifold Flush	2
	Activator to Flowcell	5
	Activator + Phosphoramidite to	18

Table 3		
General DNA Synthesis Process Name	Process Step	Time (sec)
	Flowcell	
	Incubate for 25sec	25
WASH (Acetonitrile Wash Flow)	Acetonitrile System Flush	4
	Acetonitrile to Flowcell	15
	N2 System Flush	4
	Acetonitrile System Flush	4
CAPPING (CapA+B, 1:1, Flow)	CapA+B to Flowcell	15
WASH (Acetonitrile Wash Flow)	Acetonitrile System Flush	4
	Acetonitrile to Flowcell	15
	Acetonitrile System Flush	4
OXIDATION (Oxidizer Flow)	Oxidizer to Flowcell	18
WASH (Acetonitrile Wash Flow)	Acetonitrile System Flush	4
	N2 System Flush	4
	Acetonitrile System Flush	4
	Acetonitrile to Flowcell	15
	Acetonitrile System Flush	4
	Acetonitrile to Flowcell	15
	N2 System Flush	4
	Acetonitrile System Flush	4
	Acetonitrile to Flowcell	23
	N2 System Flush	4
Acetonitrile System Flush	4	
DEBLOCKING (Deblock Flow)	Deblock to Flowcell	36
WASH (Acetonitrile Wash Flow)	Acetonitrile System Flush	4
	N2 System Flush	4
	Acetonitrile System Flush	4
	Acetonitrile to Flowcell	18
	N2 System Flush	4.13
	Acetonitrile System Flush	4.13
	Acetonitrile to Flowcell	15

[00182] The phosphoramidite/activator combination was delivered similar to the delivery of bulk reagents through the flowcell. No drying steps were performed as the environment stays "wet" with reagent the entire time.

[00183] The flow restrictor was removed from the ABI 394 synthesizer to enable faster flow. Without flow restrictor, flow rates for amidites (0.1M in ACN), Activator, (0.25M Benzoylthiotetrazole ("BTT"; 30-3070-xx from GlenResearch) in ACN), and Ox (0.02M I2 in 20% pyridine, 10% water, and 70% THF) were roughly ~100uL/sec, for acetonitrile ("ACN") and capping reagents (1:1 mix of CapA and CapB, wherein CapA is acetic anhydride in THF/Pyridine

and CapB is 16% 1-methylimidazole in THF), roughly ~200uL/sec, and for Deblock (3% dichloroacetic acid in toluene), roughly ~300uL/sec (compared to ~50uL/sec for all reagents with flow restrictor). The time to completely push out Oxidizer was observed, the timing for chemical flow times was adjusted accordingly and an extra ACN wash was introduced between different chemicals. After oligonucleotide synthesis, the chip was deprotected in gaseous ammonia overnight at 75 psi. Five drops of water were applied to the surface to assemble polynucleotides. The assembled polynucleotides were then analyzed on a BioAnalyzer small RNA chip (data not shown).

[00184] EXAMPLE 3: Synthesis of a 100-mer sequence oligonucleotides

[00185] The same process as described in Example 2 for the synthesis of the 50-mer sequence was used for the synthesis of a 100-mer oligonucleotide ("100-mer oligonucleotide"; 5' CGGGATCCTTATCGTCATCGTCGTACAGATCCCGACCCATTTGCTGTCCACCAGTCATGCTAGCCATACCATGATGATGATGATGATGAGAACCCCGCAT###TTTTTTTTTTT3', where # denotes Thymidine-succinyl hexamide CED phosphoramidite (CLP-2244 from ChemGenes); SEQ ID NO.: 2) on two different silicon chips, the first one uniformly functionalized with N-(3-TRIETHOXY-SILYL-PROPYL)-4-HYDROXYBUTYRAMIDE and the second one functionalized with 5/95 mix of 11-acetoxyundecyltriethoxysilane and n-decyltriethoxysilane, and the polynucleotides extracted from the surface were analyzed on a BioAnalyzer instrument (data not shown).

[00186] All ten samples from the two chips were further PCR amplified using a forward (5'ATGCGGGGTTCTCATCATC3'; SEQ ID NO.: 3) and a reverse (5'CGGGATCCTTATCGTCATCG3'; SEQ ID NO.: 4) primer in a 50uL PCR mix (25uL NEB Q5 mastermix, 2.5uL 10uM Forward primer, 2.5uL 10uM Reverse primer, 1uL polynucleotide extracted from the surface, and water up to 50uL) using the following thermalcycling program:

98 C, 30 sec

98 C, 10 sec; 63C, 10 sec; 72C, 10 sec; repeat 12 cycles

72C, 2min

[00187] The PCR products were also run on a BioAnalyzer (data not shown), demonstrating sharp peaks at the 100-mer position. Next, the PCR amplified samples were cloned, and Sanger sequenced. **Table 4** summarizes the results from the Sanger sequencing for samples taken from spots 1-5 from chip 1 and for samples taken from spots 6-10 from chip 2.

Table 4:

Spot	Error rate	Cycle efficiency
1	1/763 bp	99.87%

Spot	Error rate	Cycle efficiency
2	1/824 bp	99.88%
3	1/780 bp	99.87%
4	1/429 bp	99.77%
5	1/1525 bp	99.93%
6	1/1615 bp	99.94%
7	1/531 bp	99.81%
8	1/1769 bp	99.94%
9	1/854 bp	99.88%
10	1/1451 bp	99.93%

[00188] Thus, the high quality and uniformity of the synthesized oligonucleotides were repeated on two chips with different surface chemistries. Overall, 89%, corresponding to 233 out of 262 of the 100-mers that were sequenced were perfect sequences with no errors.

[00189] **Table 5** summarizes error characteristics for the sequences obtained from the oligonucleotides samples from spots 1-10.

Table 5:

Sample ID/Spot no.	OSA_0 046/1	OSA_0 047/2	OSA_0 048/3	OSA_0 049/4	OSA_0 050/5	OSA_0 051/6	OSA_0 052/7	OSA_0 053/8	OSA_0 054/9	OSA_00 55/10
Total Sequences	32	32	32	32	32	32	32	32	32	32
Sequencing Quality	25 of 28	27 of 27	26 of 30	21 of 23	25 of 26	29 of 30	27 of 31	29 of 31	28 of 29	25 of 28
Oligo Quality	23 of 25	25 of 27	22 of 26	18 of 21	24 of 25	25 of 29	22 of 27	28 of 29	26 of 28	20 of 25
ROI Match Count	2500	2698	2561	2122	2499	2666	2625	2899	2798	2348
ROI Mutation	2	2	1	3	1	0	2	1	2	1
ROI Multi Base Deletion	0	0	0	0	0	0	0	0	0	0
ROI Small Insertion	1	0	0	0	0	0	0	0	0	0
ROI Single Base Deletion	0	0	0	0	0	0	0	0	0	0
Large	0	0	1	0	0	1	1	0	0	0

Deletion Count										
Mutation: G>A	2	2	1	2	1	0	2	1	2	1
Mutation: T>C	0	0	0	1	0	0	0	0	0	0
ROI Error Count	3	2	2	3	1	1	3	1	2	1
ROI Error Rate	Err: ~1 in 834	Err: ~1 in 1350	Err: ~1 in 1282	Err: ~1 in 708	Err: ~1 in 2500	Err: ~1 in 2667	Err: ~1 in 876	Err: ~1 in 2900	Err: ~1 in 1400	Err: ~1 in 2349
ROI Minus Primer Error Rate	MP Err: ~1 in 763	MP Err: ~1 in 824	MP Err: ~1 in 780	MP Err: ~1 in 429	MP Err: ~1 in 1525	MP Err: ~1 in 1615	MP Err: ~1 in 531	MP Err: ~1 in 1769	MP Err: ~1 in 854	MP Err: ~1 in 1451

[00190] EXAMPLE 4: Highly accurate DNA-based information storage and assembly

[00191] Digital information was selected in the form of binary data totaling about 0.2 GB included content for the Universal Declaration of Human Rights in more than 100 languages, the top 100 books of Project Guttenberg and a seed database. The digital information was encrypted into a nucleic acid-based sequence and divided into strings. Over 10 million non-identical polynucleotides, each corresponding to a string, were synthesized on a rigid silicon surface in a manner similar to that described in Example 2. Each non-identical polynucleotide was under equal or less than 200 bases in length. The synthesized polynucleotides were collected and sequenced and decoded back to digital code, with 100% accuracy for the source digital information, compared to the initial at least one digital sequence.

[00192] EXAMPLE 5: Conversion of digital information to nucleic acid sequence

[00193] A computer txt file includes text information. A general purpose computer uses a software program having machine instructions for conversion of the sequence to base 3, 4, or 5 sequence, depending on instructions received. Each number in base 3 is assigned a nucleic acid (e.g., A=0, T=1, C=2). Each number in base 4 is assigned a nucleic acid (e.g., A=0, T=1, C=2, G=3). Alternatively, a base 5 quinary sequence is used, where each number in base 5 is assigned a nucleic acid (e.g., A=0, T=1, C=2, G=3, U=4). A sequence is generated as depicted in **Table 6**. Machine instructions are then provided for de novo synthesis of polynucleotides encoding the nucleic acid sequence.

Table 6.

Text	Jack went up the hill.
Binary	010010100110000101100011011010110010000001110111011001010110111

sequence	001110100001000000111010101110000001000000111010001101000011001 010010000001101000011010010110110001101100001011100000110100001 0100000110100001010
Ternary sequence	101010201100022101010021102012221200101112202210002122002210200 011112212102011201021112122200101110001002001022002222221100222 22112
Quaternary sequence	102212011203122302001313121112321310020013111300020013101220121 10200122012211230123002320031002200310022
Quinary sequence	332214330133012303013123001030244433343300431224103020320210201 12342341100431241100334213

[00194] EXAMPLE 6: Flexible surface having a high density of loci

[00195] A flexible structure comprising thermoplastic material is coated with a nucleoside coupling reagent. The coating agent is patterned for a high density of loci. A portion of the flexible surface is illustrated in **FIG. 11A**. Each locus has a diameter of 10 μm , with a center-to-center distance between two adjacent loci of 21 μm . The locus size is sufficient to accommodate a sessile drop volume of 0.2 μl during a polynucleotide synthesis deposition step. The small locus dimensions allow for a high density of polynucleotides to be synthesized on the surface of the substrate. The locus density is 2.2 billion loci / m^2 (1 locus / $441 \times 10^{-12} \text{m}^2$). A 4.5 m^2 substrate is manufactured having 10 billion loci, each with a 10 μm diameter. The flexible structure is optionally placed in a continuous loop system, **FIG. 9A**, or a reel-to-reel system, **FIG. 9B**, for polynucleotide synthesis.

[00196] EXAMPLE 7: Polynucleotide synthesis on a flexible structure

[00197] A flexible structure is prepared comprising a plurality of loci on a thermoplastic flexible material. The structure serves as a support for the synthesis of polynucleotides using a polynucleotide synthesis device comprising a deposition device. The flexible structure is in the form of a flexible media much like a magnetic reel-to-reel tape.

[00198] De novo synthesis operates in a continuous production line manner with the structure travelling through a solvent bath and then beneath a stack of printheads where the phosphoramidites are printed on to a surface of the structure. The flexible structure with the sessile drops deposited on to the surface is rolled into a bath of oxidizing agent, then the tape emerges from the oxidizing bath and is immersed in an acetonitrile wash bath then submerged in a deblock bath. Optionally, the tape is traversed through a capping bath. In an alternative workflow, the flexible structure emerges from the oxidizing bath and is sprayed with acetonitrile in a wash step.

[00199] Alternatively, a spray bar is used instead of a liquid bath. In this process, the nucleotides are still deposited on the surface with an inkjet device but the flood steps are now done in a chamber with spray nozzles. For example, the deposition device has 2,048 nozzles that each deposit 100,000 droplets per second at 1 nucleobase per droplet. There is a sequential ordering of spray nozzles to mimic the ordering of the flood steps in standard phosphoramidite chemistry. This technique provides for easily changing the chemicals loaded in the spray bar to accommodate different process steps. Polynucleotides are deprotected or cleaved in the same manner as described in Example 2.

[00200] For each deposition device, more than 1.75×10^{13} nucleobases are deposited on the structure per day. A plurality of 200 nucleobase polynucleotides is synthesized. In 3 days, at a rate of 1.75×10^{13} bases per day, 262.5×10^9 polynucleotides are synthesized. Each oligonucleotide sequence comprises a polynucleotide of at least 15 bases embedded in a longer polynucleotide. In one instance, the polynucleotide is designed to have at least, in 5' to 3' order: a linker region, cleavage region, a first primer binding region, a bar code region, target sequence regions, and a second primer region.

[00201] EXAMPLE 8: Electrostatic transfer of polynucleotides following de novo synthesis

[00202] Polynucleotides are synthesized similarly to Examples 2-3. Following polynucleotide synthesis, the polynucleotides are transferred from a channel in a structure to one or more channels or a receiving unit using electrostatic force.

[00203] An aqueous or gaseous transfer media that adheres to the polynucleotides is deposited. The channel is surrounded by interconnected conductor plates located above the channel. The transfer media comprises a charge (positive or negative) that reacts with an electrostatic field created by the conductor plates. A voltage potential is applied between the interconnected conductor plates, resulting in attraction of the transfer media and transfer of the polynucleotides through an opening of the channel.

[00204] In order to repel the polynucleotides from the channel, the channel is surrounded by interconnected conductor plates located below the channel. When voltage potential is applied between the interconnected conductor plates, the transfer media is repelled from the channel to one or more channels or the receiving unit.

[00205] EXAMPLE 9: Transfer of polynucleotides following de novo synthesis using vibrational force

[00206] Polynucleotides are synthesized similarly to Examples 2-3. Following polynucleotide synthesis, the polynucleotides are transferred from a channel in a structure to one or more channels or a receiving unit using vibrational force.

[00207] An aqueous or gaseous transfer media that adheres to the polynucleotides is deposited. The channel is surrounded by vibrational energy applicators. Vibrational energy is applied through the vibrational energy applicators, resulting in transfer of the polynucleotides through an opening of the channel to one or more channels or the receiving unit.

[00208] EXAMPLE 10: Transfer of polynucleotides following de novo synthesis using a slip

[00209] Polynucleotides are synthesized similarly to Examples 2-3. Following polynucleotide synthesis, the polynucleotides are transferred from a channel in a structure to one or more channels or a receiving unit using a slip.

[00210] An aqueous or gaseous transfer media that adheres to the polynucleotides is deposited. A slip is positioned in contact with the structure at an angle. By rotating the slip relative to the structure, for example at either 10°, 20°, 30°, 40°, 50°, 60°, 70° or 80°, the transfer media is transferred to one or more channels or the receiving unit.

[00211] EXAMPLE 11: Transfer of polynucleotides following de novo synthesis using applied pressure

[00212] Polynucleotides are synthesized similarly to Examples 2-3. Following polynucleotide synthesis, the polynucleotides are transferred from a channel in a structure to one or more channels or a receiving unit using applied pressure.

[00213] An aqueous or gaseous transfer media that adheres to the polynucleotides is deposited. An applied pressure within a gas or fluid and a pressure release are employed to force the transfer media through a channel in the structure. By creating a pressure differential, opening of a pressure release forces the transfer media through the channel.

[00214] EXAMPLE 12: Transfer of polynucleotides following de novo synthesis using applied pressure and a nozzle

[00215] Polynucleotides are synthesized similarly to Examples 2-3. Following polynucleotide synthesis, the polynucleotides are transferred from a channel in a flexible structure to one or more channels or a receiving unit using applied pressure and a nozzle.

[00216] An aqueous or gaseous transfer media that adheres to the polynucleotides is deposited. The flexible structure is moved using a roller such that the channel is aligned below a nozzle. The nozzle then applies pressure towards a channel and forces the transfer media through the channel.

[00217] EXAMPLE 13: Transfer of polynucleotides following de novo synthesis using a pin

[00218] Polynucleotides are synthesized similarly to Examples 2-3. Following polynucleotide synthesis, the polynucleotides are transferred from a channel in a structure to one or more channels or a receiving unit using a pin.

[00219] An aqueous or gaseous transfer media that adheres to the polynucleotides is deposited. The pin contacts and attracts the transfer media and a relative vertical motion between the pin and the structure dislocates the transfer media from the structure to one or more channels or the receiving unit.

[00220] While preferred embodiments of the present invention have been shown and described herein, it will be obvious to those skilled in the art that such embodiments are provided by way of example only. Numerous variations, changes, and substitutions will now occur to those skilled in the art without departing from the invention. It should be understood that various alternatives to the embodiments of the invention described herein may be employed in practicing the invention. It is intended that the following claims define the scope of the invention and that methods and structures within the scope of these claims and their equivalents be covered thereby.

CLAIMS

WHAT IS CLAIMED IS:

1. A method for storing and accessing information, the method comprising:
 - a) converting at least one item of information in a form of at least one digital sequence to at least one nucleic acid sequence;
 - b) providing a structure comprising a surface;
 - c) synthesizing a plurality of polynucleotides having predetermined sequences collectively encoding for the at least one nucleic acid sequence, wherein each polynucleotide extends from the surface;
 - d) storing the plurality of polynucleotides; and
 - e) selectively transferring the plurality of polynucleotides to a receiving unit, wherein selectively transferring comprises application of a force, wherein the force is laminar pressure, capillary pressure, slip flow pressure, magnetic force, electrostatic force, peristaltic force, sound waves, vibrational force, centripetal force, centrifugal force, or any combination thereof, and wherein the plurality of polynucleotides collectively encodes for a single nucleic acid sequence of the at least one nucleic acid sequence.
2. The method of claim 1, wherein the application of force comprises a conducting member, and an applied voltage potential between the structure and the conducting member.
3. The method of claim 1, wherein the application of force comprises contacting the surface of the structure with a rigid or flexible slip.
4. The method of claim 1, wherein the application of force comprises a pressure release or pressure nozzle.
5. The method of claim 4, further comprising using the pressure nozzle during step (c).
6. The method of claim 4, further comprising flooding the polynucleotides through the pressure nozzle.
7. The method of claim 4, further comprising depositing nucleotides through the pressure nozzle.
8. The method of claim 1, further comprising:
 - sequencing the plurality of polynucleotides; and
 - assembling the at least one digital sequence.

9. The method of claim 8, wherein the at least one digital sequence assembled is 100% accurate compared to an initial at least one digital sequence.
10. A method for storing information, the method comprising:
 - a) converting at least one item of information in a form of at least one digital sequence to at least one nucleic acid sequence;
 - b) synthesizing a plurality of polynucleotides having predetermined sequences collectively encoding for the at least one nucleic acid sequence, wherein each polynucleotide comprises:
 - i) a plurality of coding regions, wherein each coding region is identical; and
 - ii) at least one non-coding region, wherein the at least one non-coding region comprises a cleavage region; and
 - c) storing the plurality of polynucleotides.
11. The method of claim 10, wherein the cleavage region comprises a restriction enzyme recognition site.
12. The method of claim 10, wherein the cleavage region comprises a light sensitive nucleobase.
13. The method of claim 10, further comprising application of a restriction enzyme, electromagnetic radiation, or a gaseous reagent to cleave at the cleavage region, thereby removing at least one of the plurality of coding regions.
14. The method of claim 10, wherein each coding region comprises 25 to 500 bases in length.
15. The method of claim 10, wherein each coding region comprises 100 to 2000 bases in length.
16. The method of claim 10, wherein each non-coding region comprises 1 to 100 bases in length.
17. The method of claim 10, wherein each non-coding region comprises at most 200 bases.
18. The method of claim 10, wherein the plurality of polynucleotides comprises at least 100,000 polynucleotides.
19. The method of claim 10, wherein the plurality of polynucleotides comprises at least 10 billion polynucleotides.
20. The method of claim 10, wherein greater than 90% of the polynucleotides encode for a sequence that does not differ from the predetermined sequence.

21. The method of claim 10, wherein the at least one item of information is text information, audio information or visual information.
22. The method of claim 10, wherein a first non-coding region within each polynucleotide has a different sequence than a second non-coding region within each polynucleotide.
23. The method of claim 10, wherein each non-coding region within each polynucleotide has a different sequence.
24. The method of claim 10, wherein a first cleavage region within each polynucleotide has a different sequence than a second cleavage region within each polynucleotide.
25. The method of claim 10, wherein each cleavage region within each polynucleotide has a different sequence.
26. The method of claim 10, wherein a number of cleavage regions within each polynucleotide is at least 1, 2, 3, 4, or 5.
27. The method of claim 26, wherein a sequence for the number of cleavage regions is different.
28. The method of claim 10, wherein each polynucleotide comprises a tether region.
29. A method for encrypting information, the method comprising:
 - a) converting at least one item of information in a form of at least one digital sequence to at least one nucleic acid sequence;
 - b) associating each of the at least one nucleic acid sequence with one of a plurality of non-identical markings;
 - c) providing a structure having a surface, wherein the surface comprises the plurality of non-identical markings;
 - d) synthesizing a plurality of polynucleotides having predetermined sequences collectively encoding for the at least one nucleic acid sequence, wherein the plurality of polynucleotides comprises at least 100,000 polynucleotides, and wherein each polynucleotide extends from the surface in a discrete region demarcated by one of the non-identical markings; and
 - e) storing the plurality of polynucleotides.
30. The method of claim 29, wherein the plurality of polynucleotides comprises at least 1,000,000 polynucleotides.
31. The method of claim 29, wherein greater than 90% of the polynucleotides encode for a sequence that does not differ from the predetermined sequence.

32. The method of claim 29, wherein the at least one item of information is text information, audio information or visual information.
33. The method of claim 29, wherein a subset of the polynucleotides discretely demarcated by one of the non-identical markings comprise a same sequence.
34. The method of claim 29, further comprising selecting a subset of polynucleotides discretely demarcated by one of the non-identical markings, releasing the subset of polynucleotides, sequencing the plurality of polynucleotides, decrypting the plurality of polynucleotides, and assembling the at least one digital sequence.
35. The method of claim 29, further comprising selecting a subset of polynucleotides discretely demarcated by one of the non-identical markings, amplifying the subset of polynucleotides, sequencing the subset of polynucleotides, decrypting the plurality of polynucleotides, and assembling the at least one digital sequence.
36. The method of claim 34 or 35, wherein the at least one digital sequence assembled is 100% accurate compared to an initial at least one digital sequence.
37. The method of claim 35, wherein the at least one digital sequence comprises an amount of digital information of at least 1 gigabyte.
38. The method of claim 35, wherein the at least one digital sequence comprises an amount of digital information of at least 1 terabyte.
39. The method of claim 35, wherein the at least one digital sequence comprises an amount of digital information of at least 1 petabyte.
40. A method for collection of information, the method comprising:
 - a) providing a structure comprising a surface, wherein the structure comprises:
 - a first plurality of polynucleotides having predetermined sequences collectively encoding for at least one nucleic acid sequence; and
 - a second plurality of polynucleotides having predetermined sequences collectively encoding for the at least one nucleic acid sequence, wherein the first plurality of polynucleotides and the second plurality of polynucleotides both extend from the surface and both encode for the same at least one nucleic acid sequence;
 - b) selectively separating a region of the structure comprising the first plurality of polynucleotides and removing the first plurality of polynucleotides from the surface; and
 - c) sequencing and decrypting the at least one nucleic acid sequence to form at least one digital sequence encoding for an item of information.

41. The method of claim 40, wherein a region of the structure comprising the first plurality of polynucleotides comprises a cluster of channels or wells.
42. The method of claim 40, wherein the structure is a rigid structure.
43. The method of claim 40, wherein the structure is a flexible structure.
44. The method of claim 40, wherein a region of the structure comprising only a remaining portion of the structure lacking the first plurality of polynucleotides is spliced back together.
45. The method of claim 40, wherein selectively removing comprises application of force to a region of the structure comprising the first plurality of polynucleotides.
46. The method of claim 45, wherein the application of force is laminar pressure, capillary pressure, slip flow pressure, magnetic force, electrostatic force, peristaltic force, sound waves, vibrational force, centripetal force, centrifugal force, or any combination thereof.
47. The method of claim 45, wherein the application of force comprises a conducting member, and an applied voltage potential between the structure and the conducting member.
48. The method of claim 45, wherein the application of force comprises contacting the surface of the structure with a rigid or flexible slip.
49. The method of claim 45, wherein the application of force comprises a pressure release or pressure nozzle.
50. The method of claim 40, wherein each polynucleotide of the first plurality of nucleotides comprises at most 500 bases in length.
51. The method of claim 40, wherein each polynucleotide of the first plurality of nucleotides comprises at most 200 bases in length.
52. The method of claim 40, wherein each polynucleotide of the second plurality of nucleotides comprises at most 500 bases in length.
53. The method of claim 40, wherein each polynucleotide of the second plurality of nucleotides comprises at most 200 bases in length.
54. The method of claim 40, wherein an amount of the item of information is at least one gigabyte.
55. The method of claim 40, wherein an amount of the item of information is at least one terabyte.
56. The method of claim 40, wherein an amount of the item of information is at least one petabyte.

57. A nucleic acid library, comprising a plurality of polynucleotides, wherein each of the polynucleotides comprises:
- i) a plurality of coding regions, wherein each coding region is identical; and
 - ii) at least one non-coding region, wherein the at least one non-coding region comprises a cleavage region;
- and wherein when the plurality of polynucleotides are sequenced, decrypted, and assembled to form a digital sequence, the digital sequence has greater than 90% accuracy compared to a preselected digital sequence.
58. The nucleic acid library of claim 57, wherein the cleavage region comprises a restriction enzyme recognition site.
59. The nucleic acid library of claim 57, wherein the cleavage region comprises a light sensitive nucleobase.
60. The nucleic acid library of claim 57, further comprising application of a restriction enzyme, electromagnetic radiation, or a gaseous reagent to cleave at the cleavage region, thereby removing at least one of the plurality of coding regions.
61. The nucleic acid library of claim 57, wherein each coding region comprises 25 to 500 bases in length.
62. The nucleic acid library of claim 57, wherein each coding region comprises 100 to 2000 bases in length.
63. The nucleic acid library of claim 57, wherein each non-coding region comprises 1 to 100 bases in length.
64. The nucleic acid library of claim 57, wherein each non-coding region comprises at most 200 bases.
65. The nucleic acid library of claim 57, wherein the plurality of polynucleotides comprises at least 100,000 polynucleotides.
66. The nucleic acid library of claim 57, wherein the plurality of polynucleotides comprises at least 10 billion polynucleotides.
67. The nucleic acid library of claim 57, wherein greater than 90% of the polynucleotides encode for a sequence that does not differ from a predetermined sequence.
68. The nucleic acid library of claim 57, wherein a first non-coding region within each polynucleotide has a different sequence than a second non-coding region within each polynucleotide.

69. The nucleic acid library of claim 57, wherein each non-coding region within each polynucleotide has a different sequence.
70. The nucleic acid library of claim 57, wherein a first cleavage region within each polynucleotide has a different sequence than a second cleavage region within each polynucleotide.
71. The nucleic acid library of claim 57, wherein each cleavage region within each polynucleotide has a different sequence.
72. The nucleic acid library of claim 57, wherein a number of cleavage regions within each polynucleotide is at least 1, 2, 3, 4, or 5.
73. The nucleic acid library of claim 72, wherein a sequence for the number of cleavage regions is different.
74. A device for storing information, the device comprising:
- a) a structure having a surface; and
 - b) a plurality of discrete regions on the surface for synthesizing a plurality of polynucleotides having predetermined sequences collectively encoding for at least one nucleic acid sequence, wherein each polynucleotide comprises:
 - i) a plurality of coding regions, wherein each coding region is identical; and
 - ii) at least one non-coding region, wherein the at least one non-coding region comprises a cleavage region; and

wherein the at least one nucleic acid sequence encodes for at least one item of information.

75. A device for encrypting information, the device comprising:
- a) a structure having a surface, wherein the surface comprises a plurality of non-identical markings; and
 - b) a plurality of discrete regions on the surface for synthesizing a plurality of polynucleotides having predetermined sequences collectively encoding for at least one nucleic acid sequence, wherein the plurality of polynucleotides comprises at least 100,000 polynucleotides, and wherein each polynucleotide extends from the surface in a discrete region demarcated by one of the non-identical markings; and

wherein the at least one nucleic acid sequence encodes for at least one item of information.

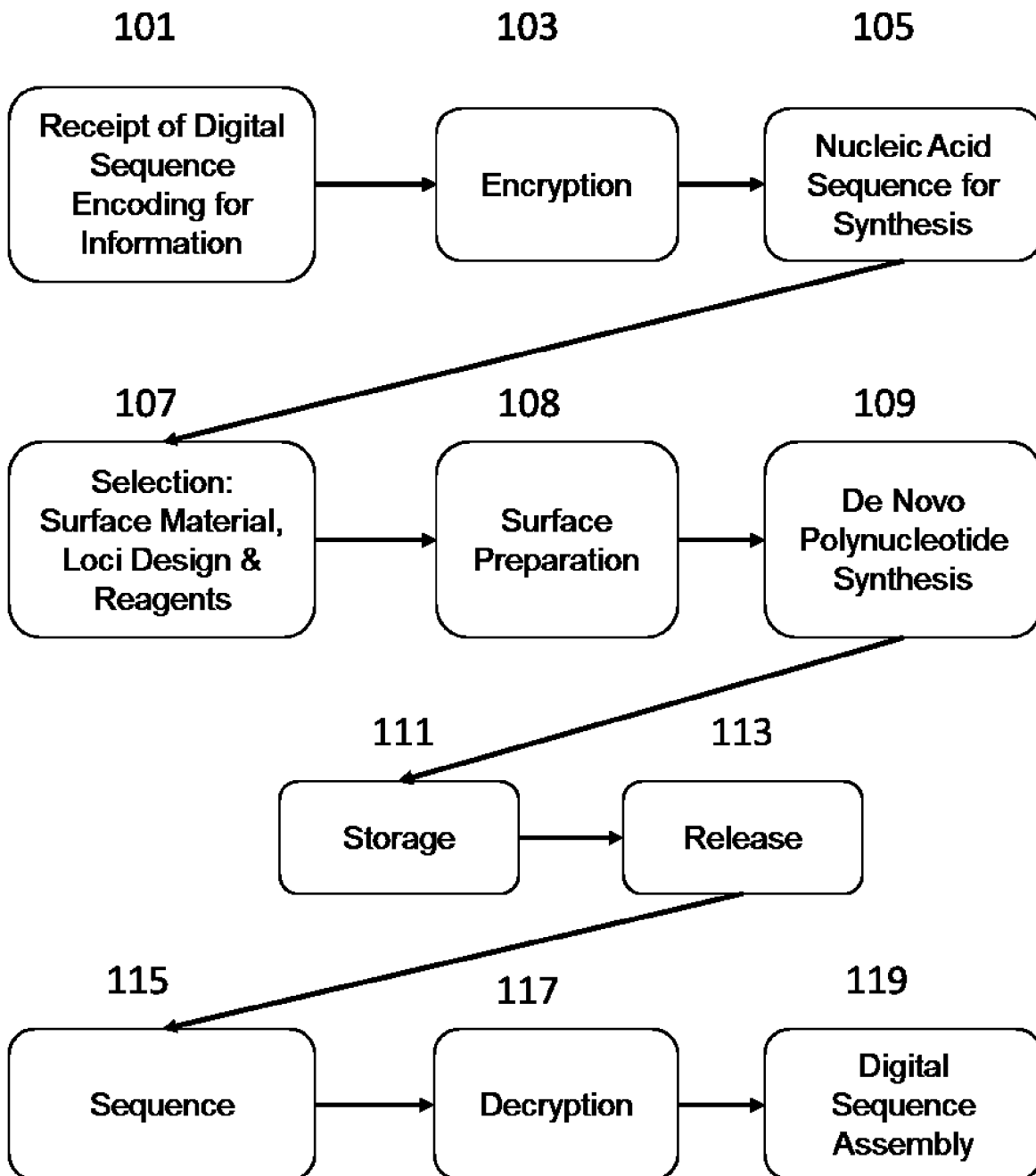
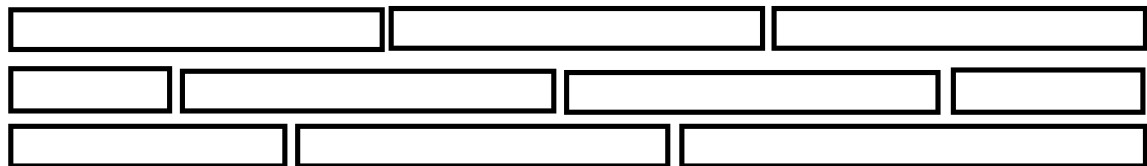
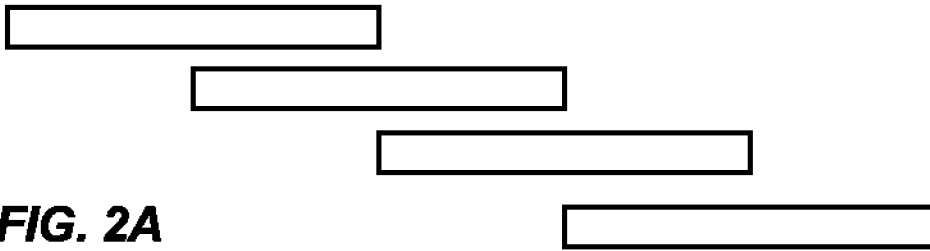

FIG. 1



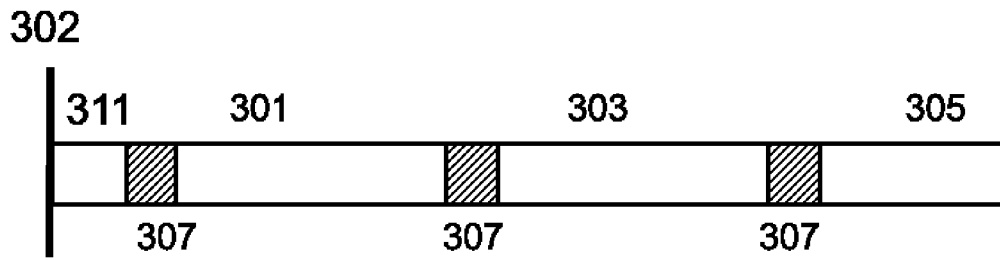

FIG. 3A

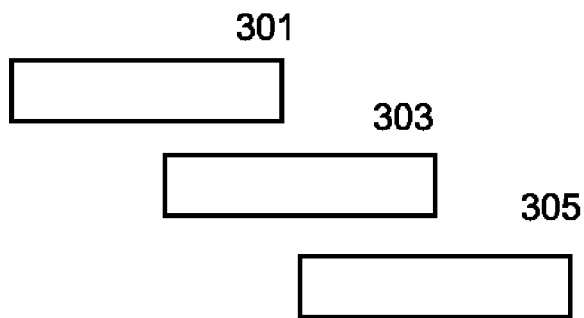

FIG. 3B

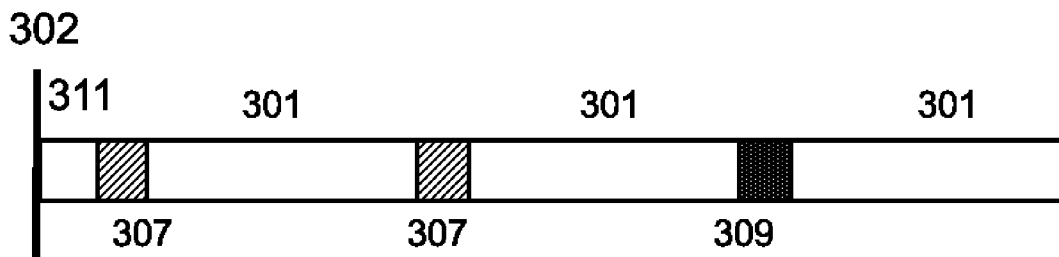

FIG. 3C

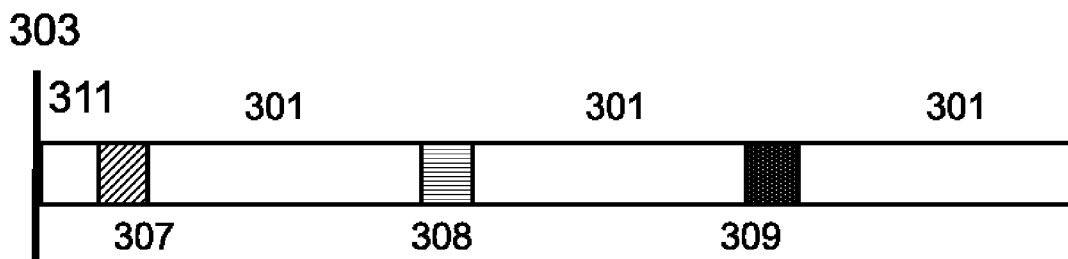

FIG. 3D

302

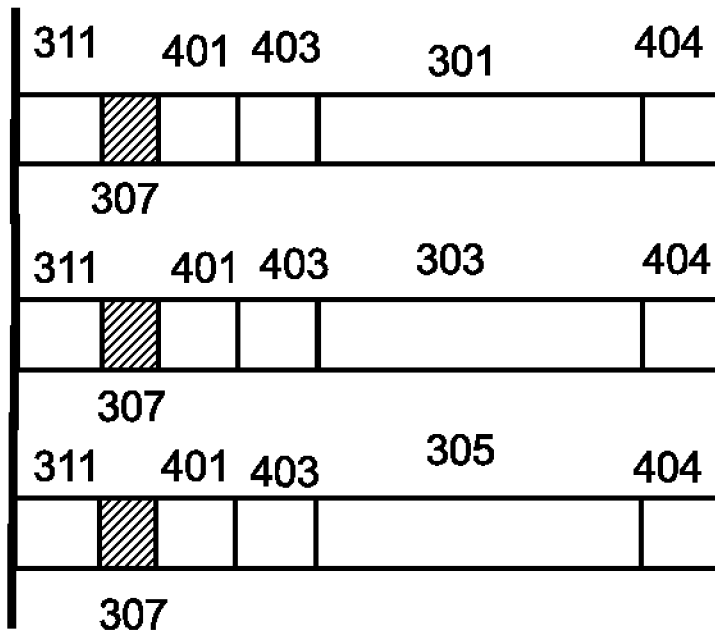

FIG. 4A

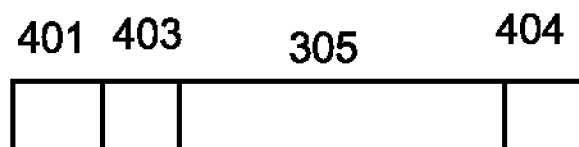
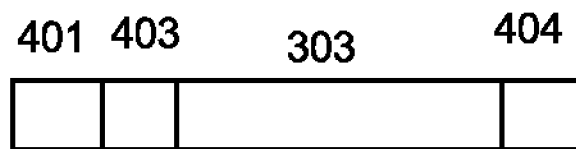
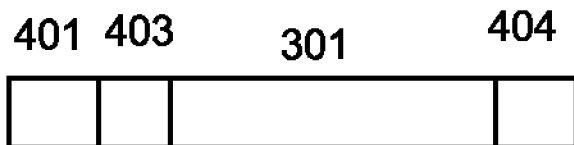

FIG. 4B

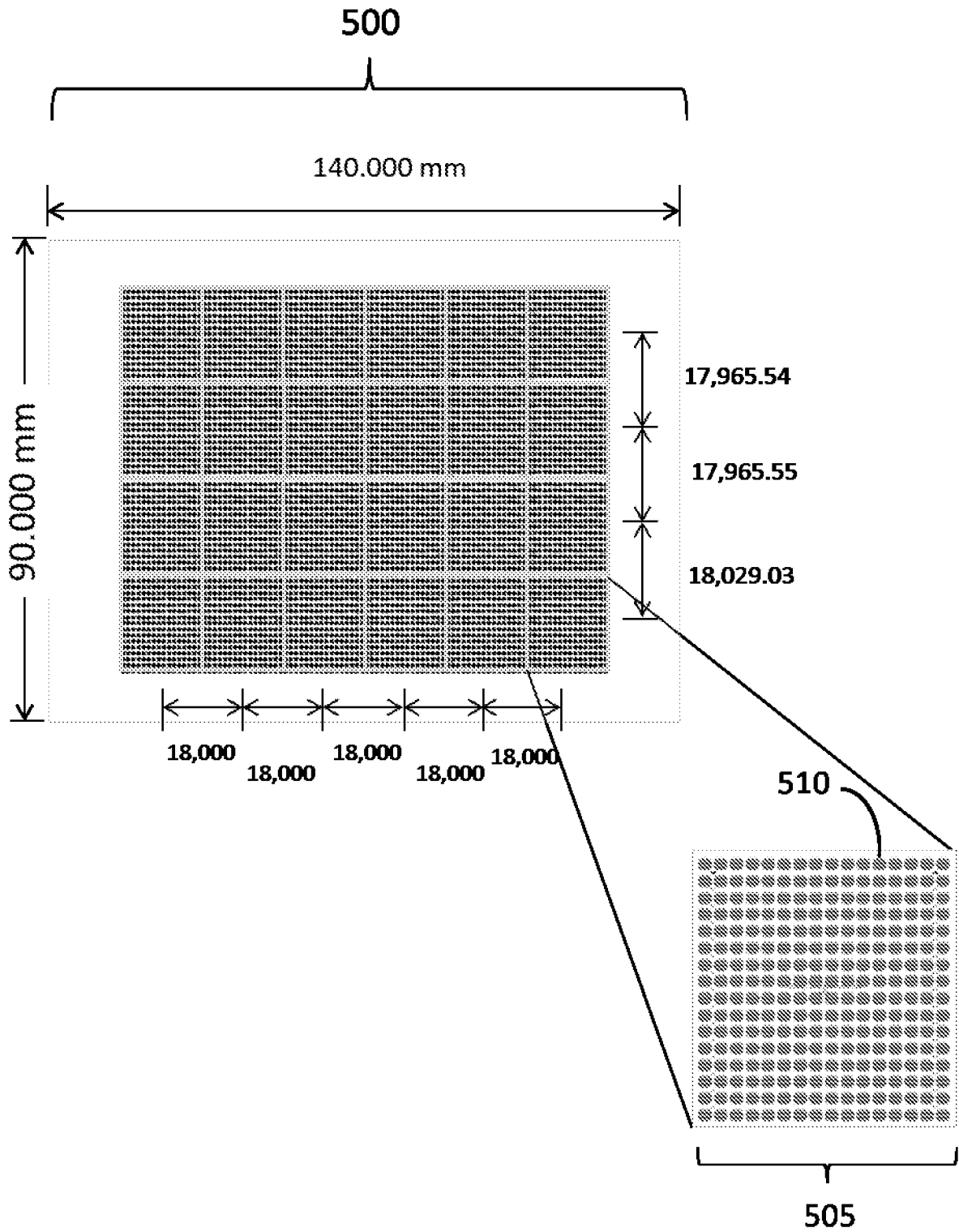

FIG. 5

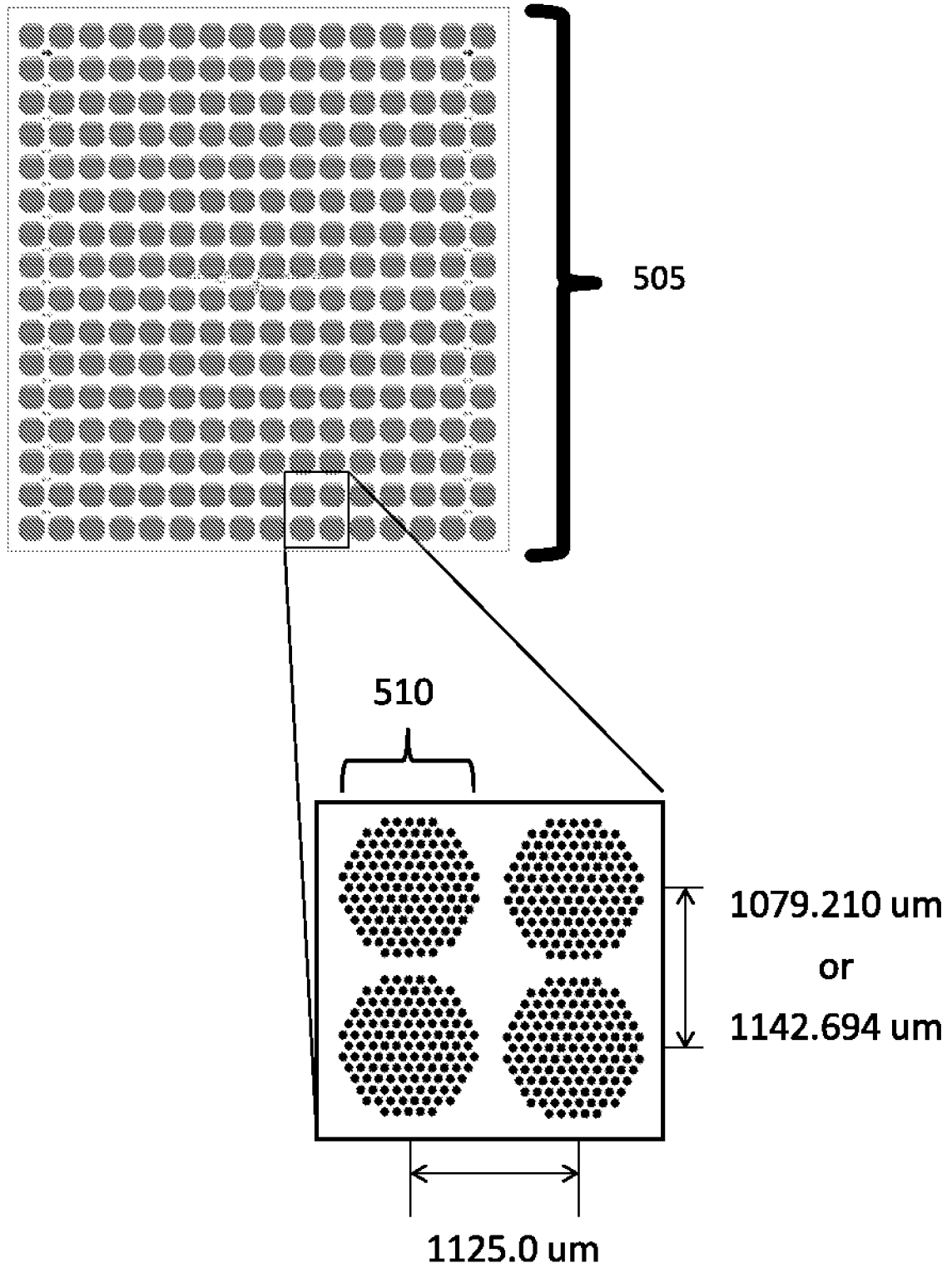

FIG. 6

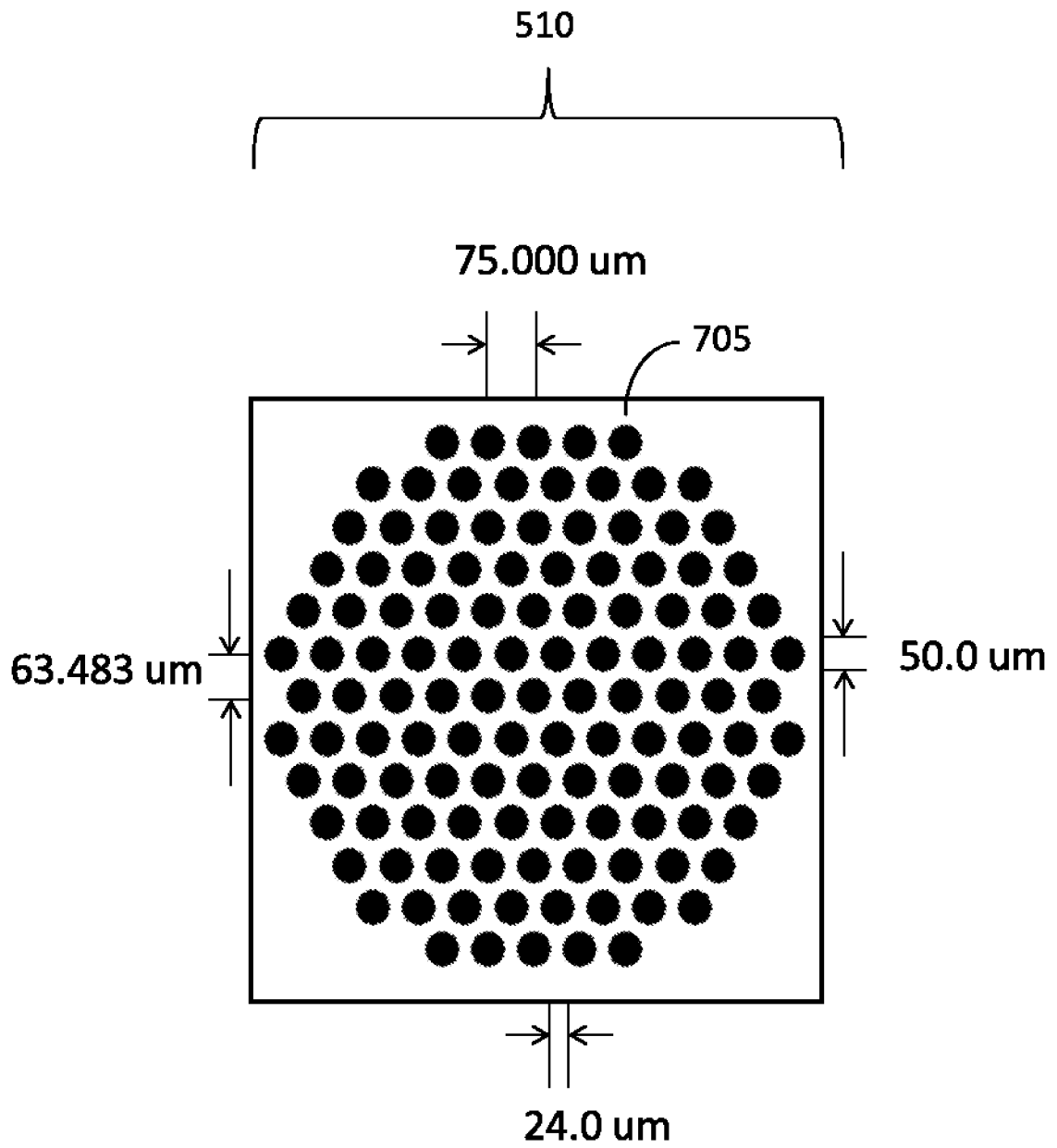

FIG. 7

8/27

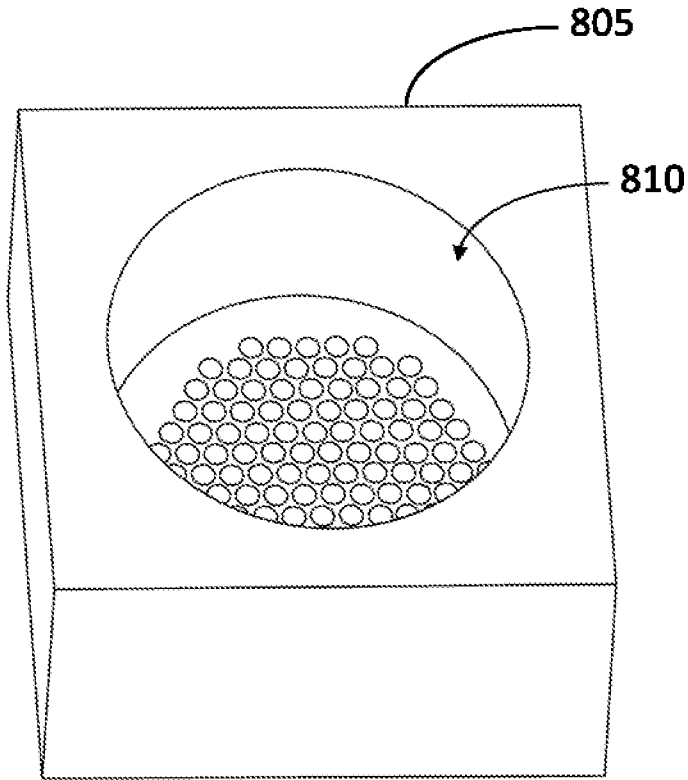

FIG. 8A

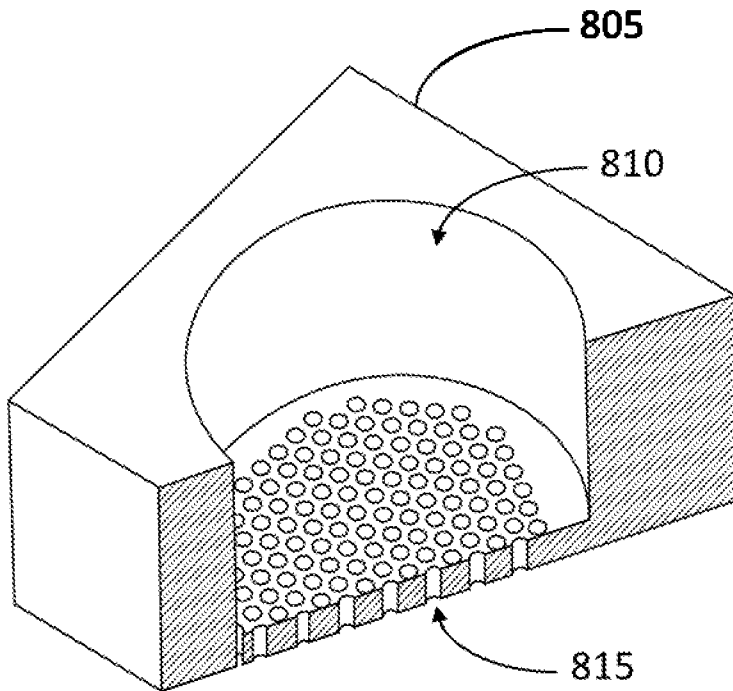

FIG. 8B

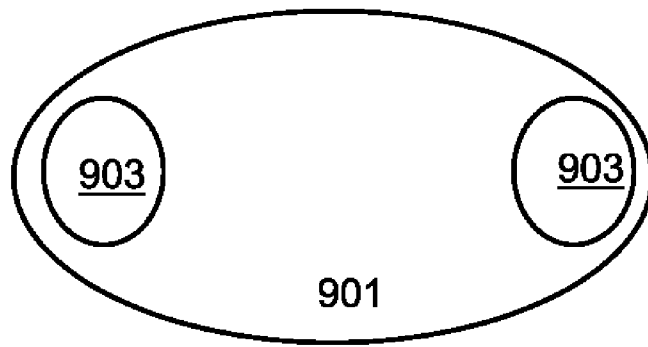

FIG. 9A

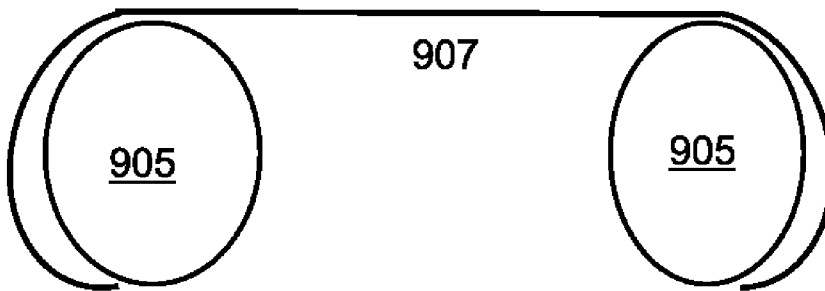

FIG. 9B

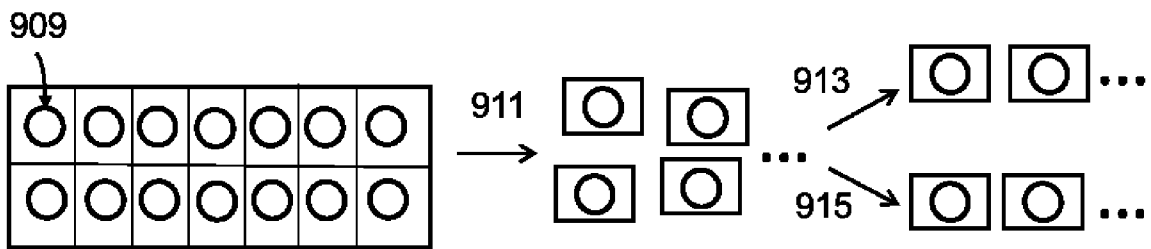

FIG. 9C

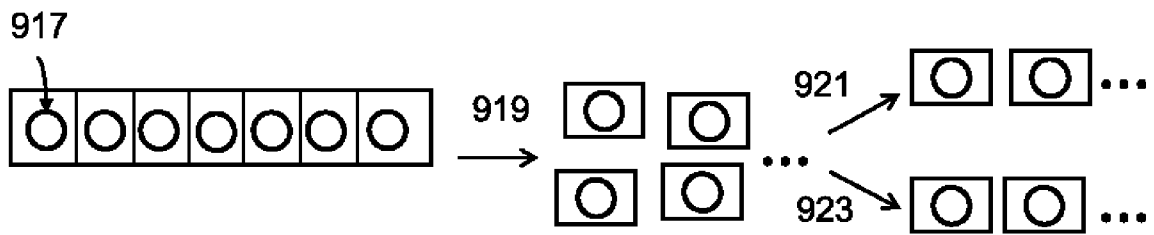
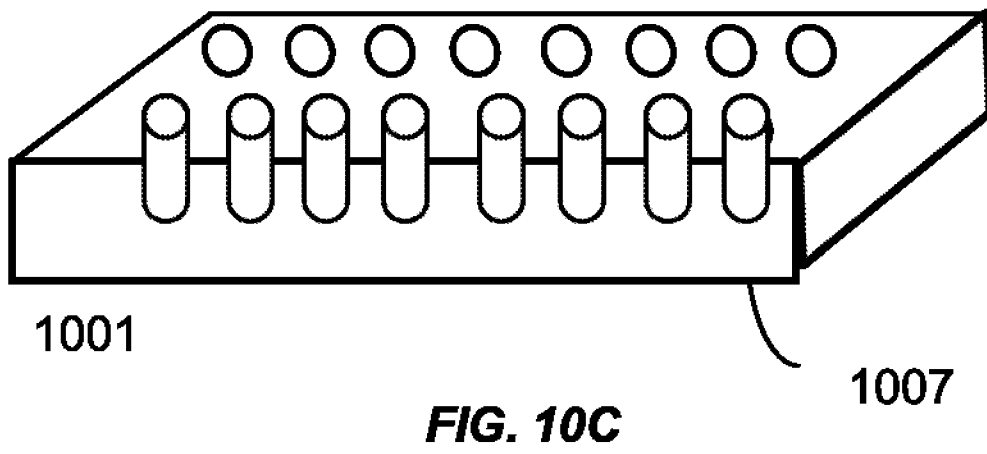
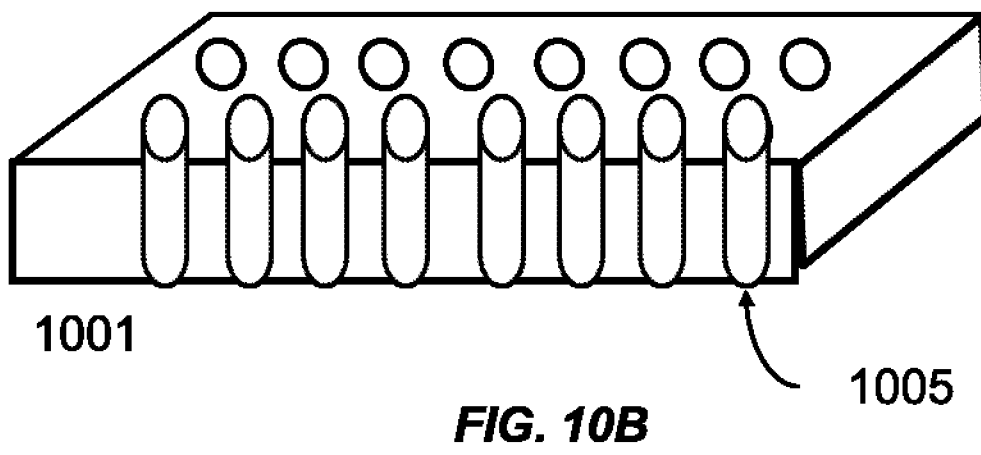
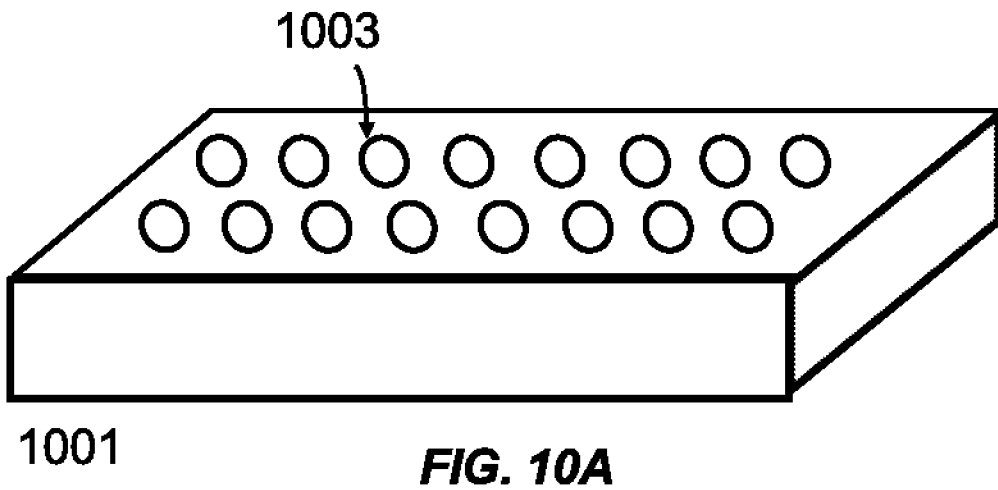

FIG. 9D

10/27



11/27

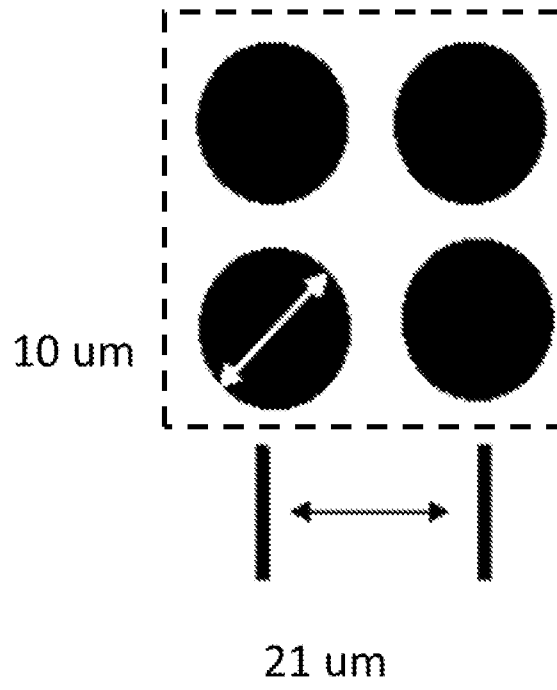

FIG. 11A

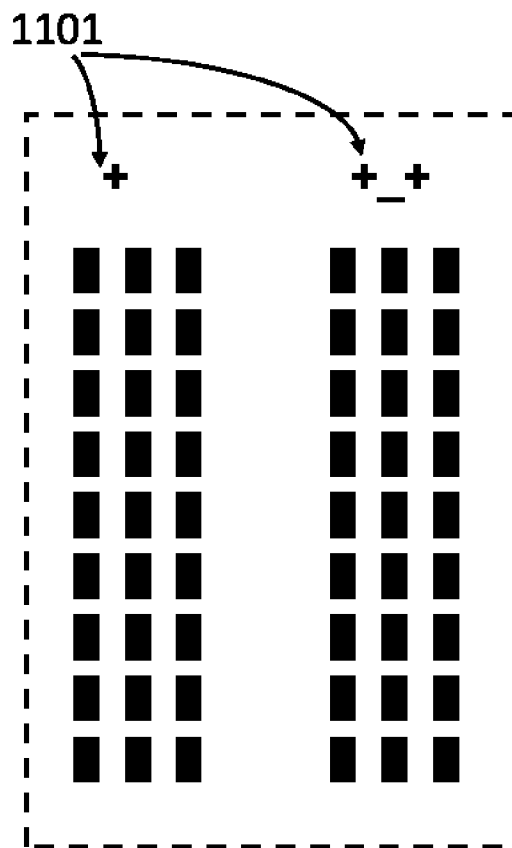

FIG. 11B

12/27

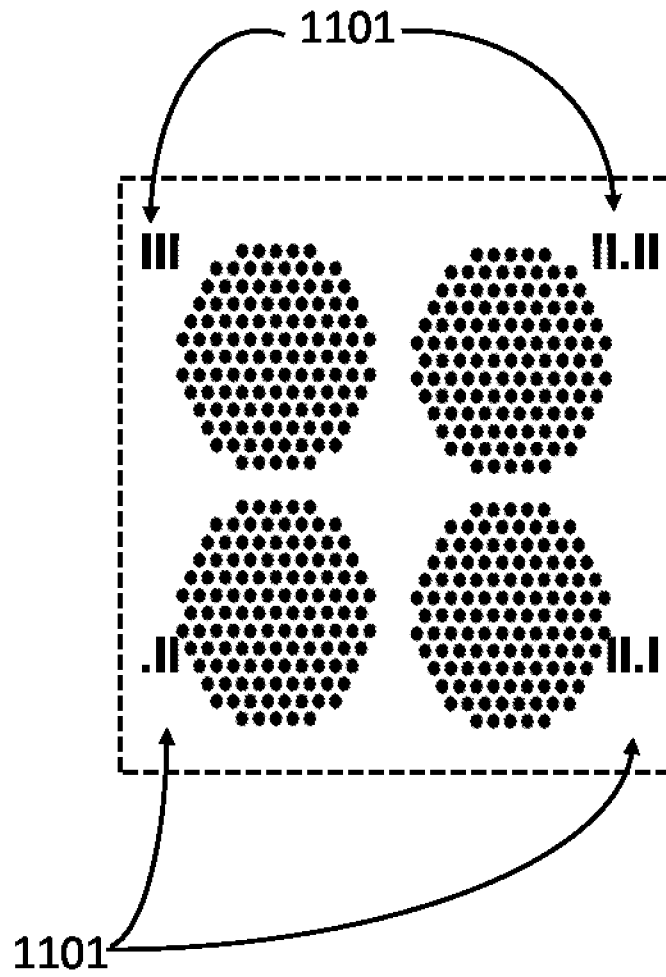

FIG. 11C

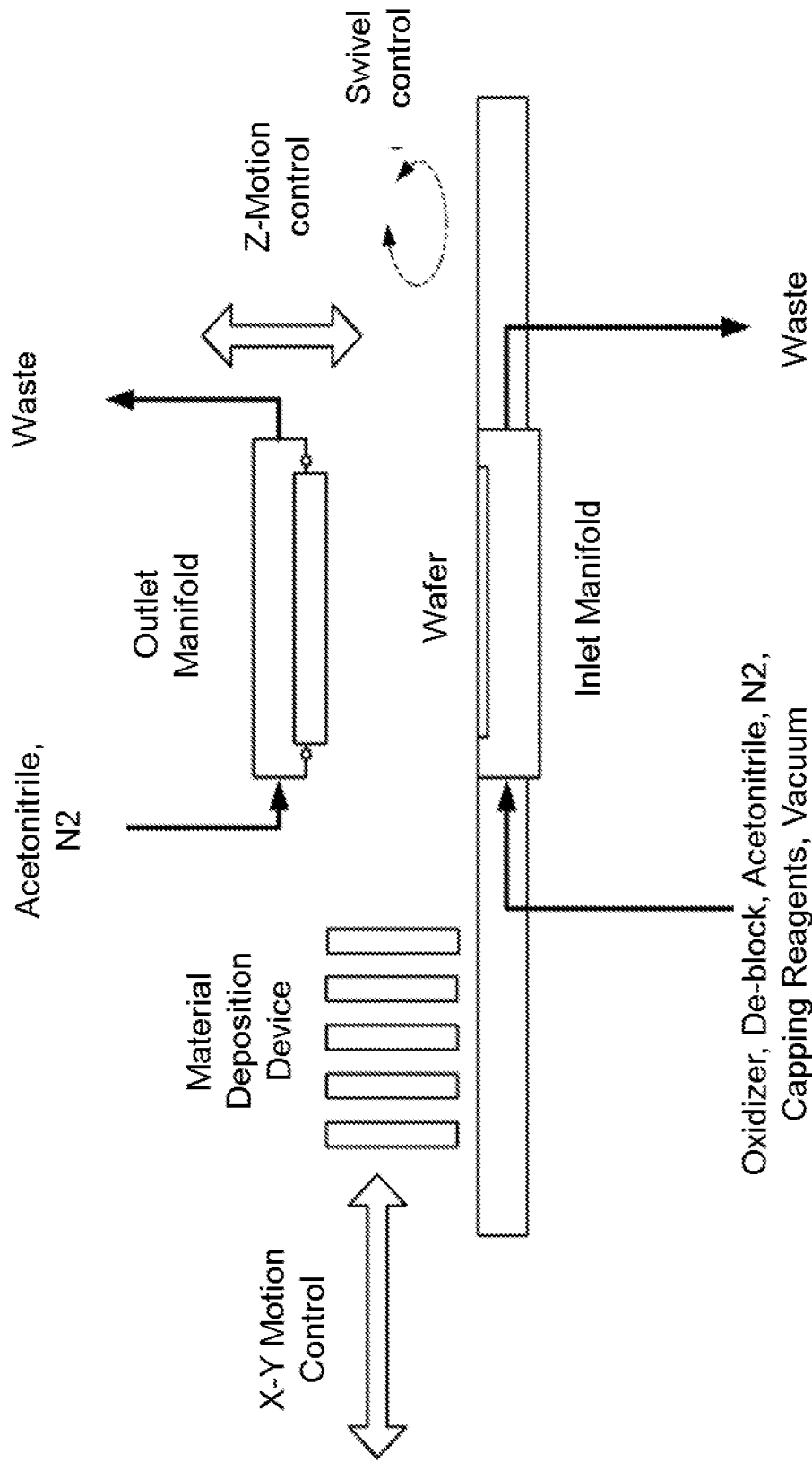

FIG. 12

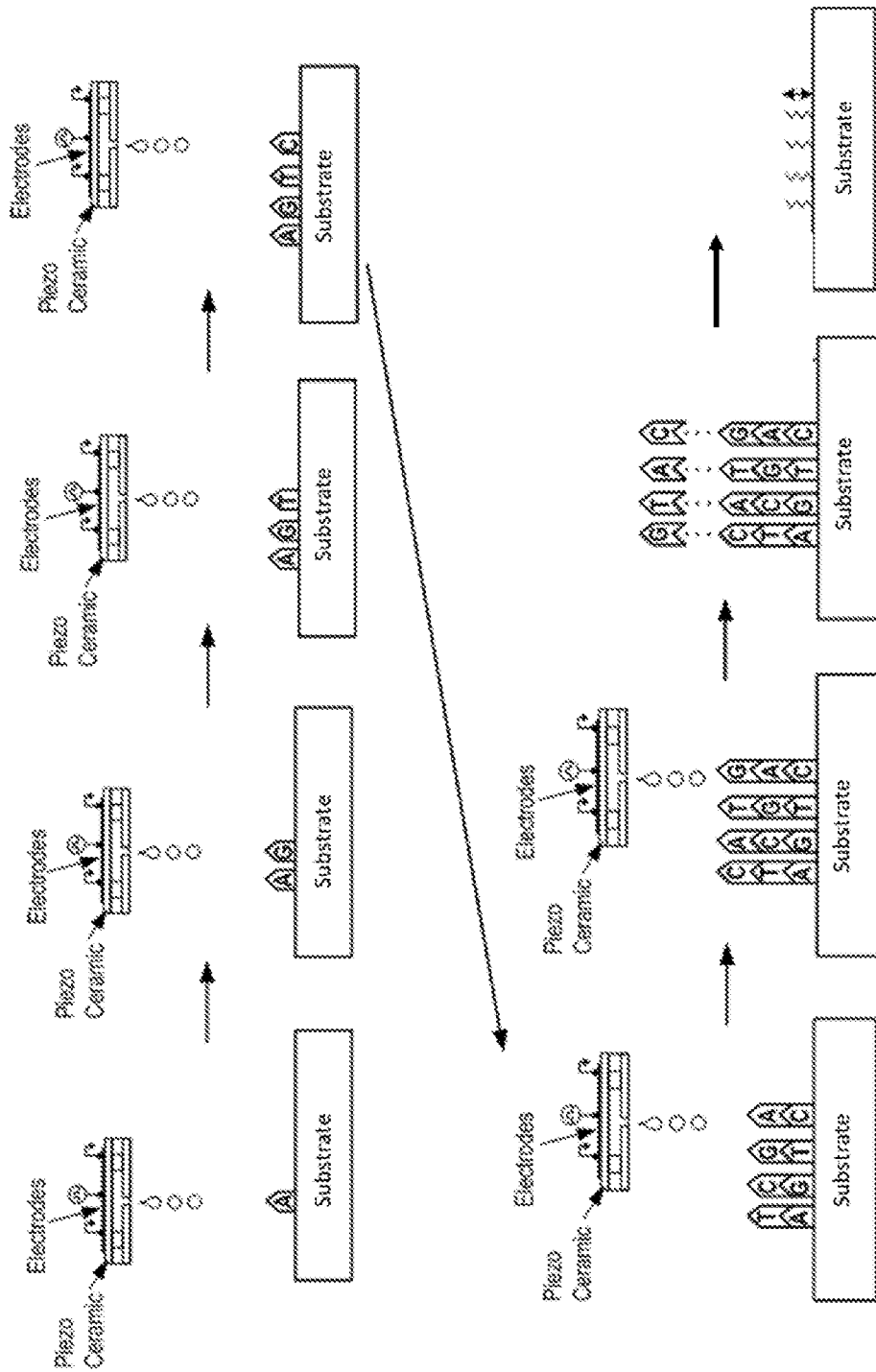

FIG. 13

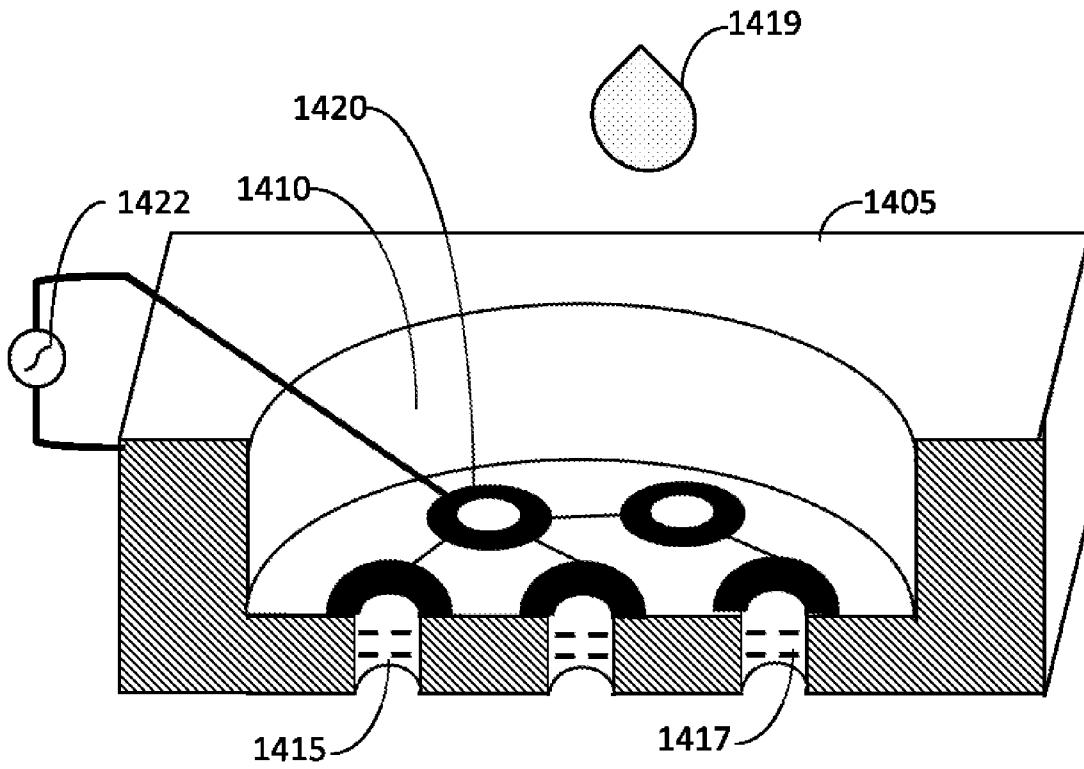

FIG. 14A

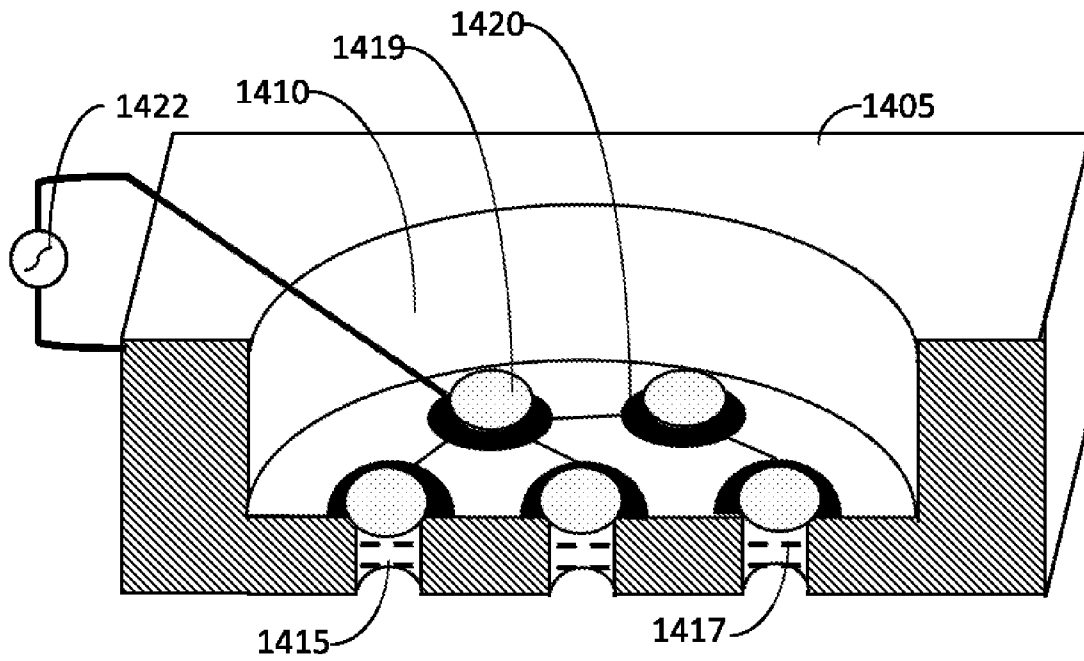

FIG. 14B

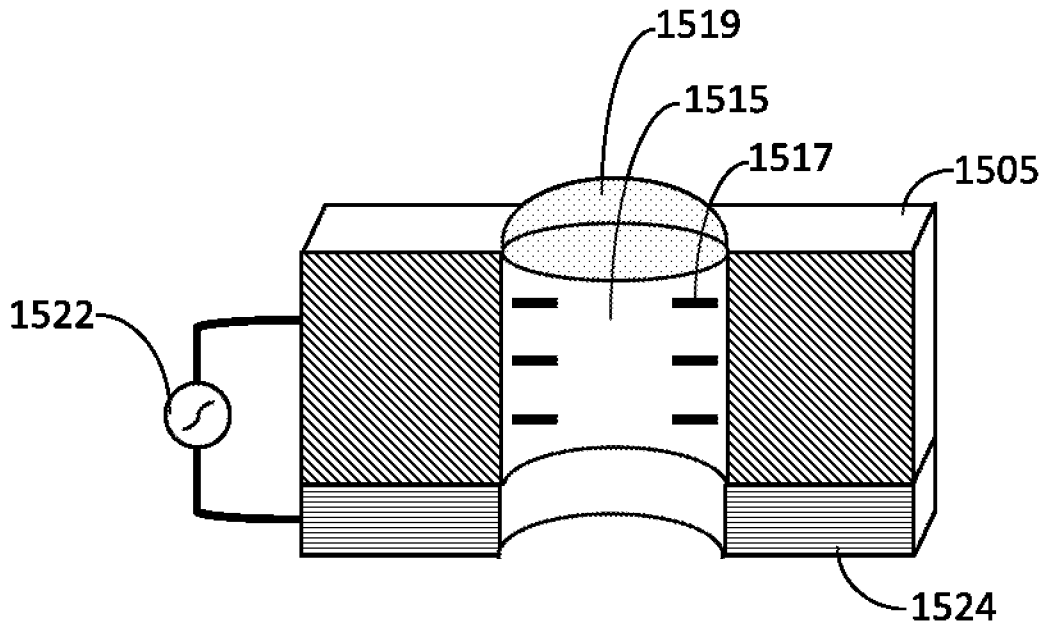

FIG. 15A

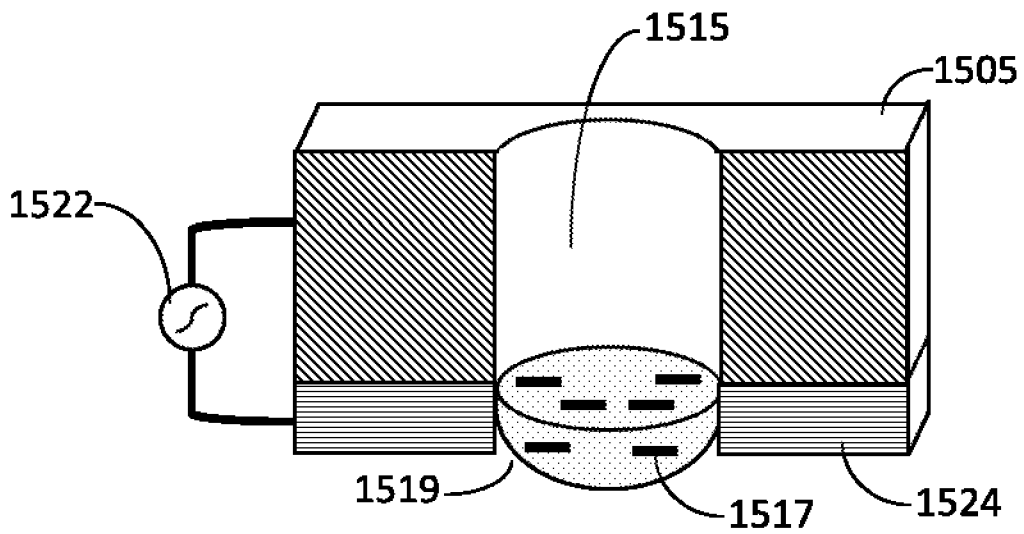

FIG. 15B

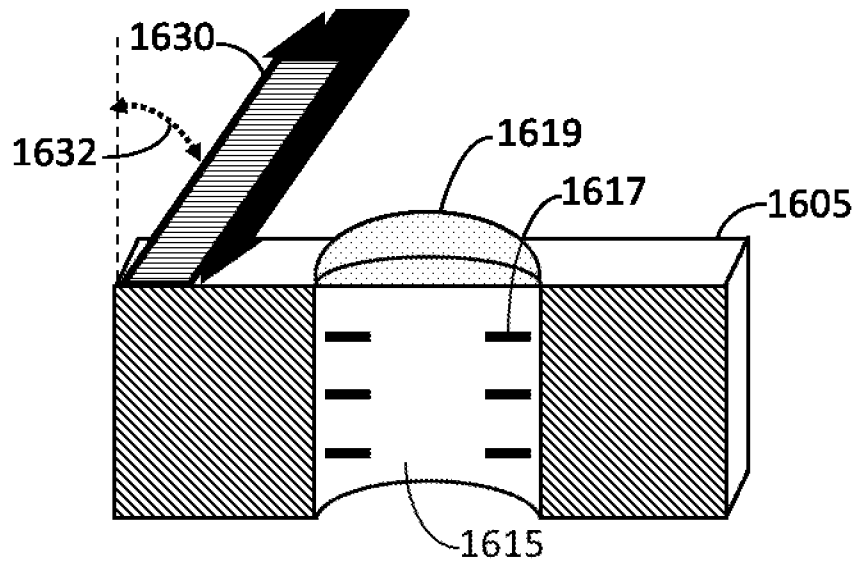

FIG. 16A

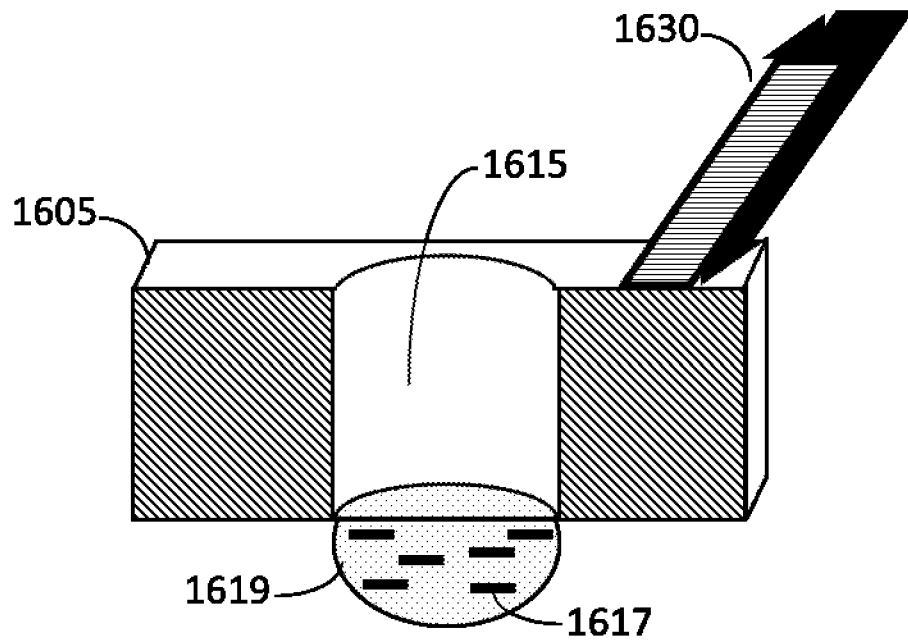

FIG. 16B

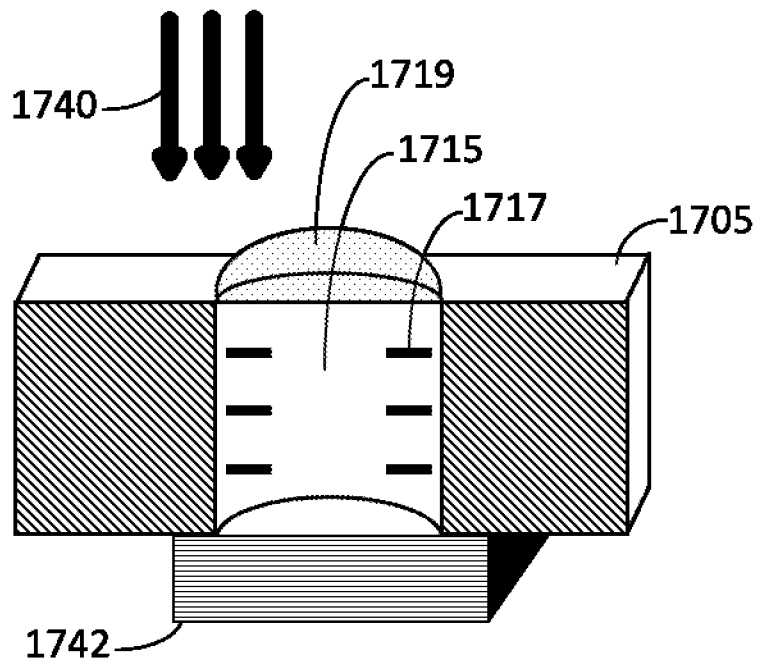

FIG. 17A

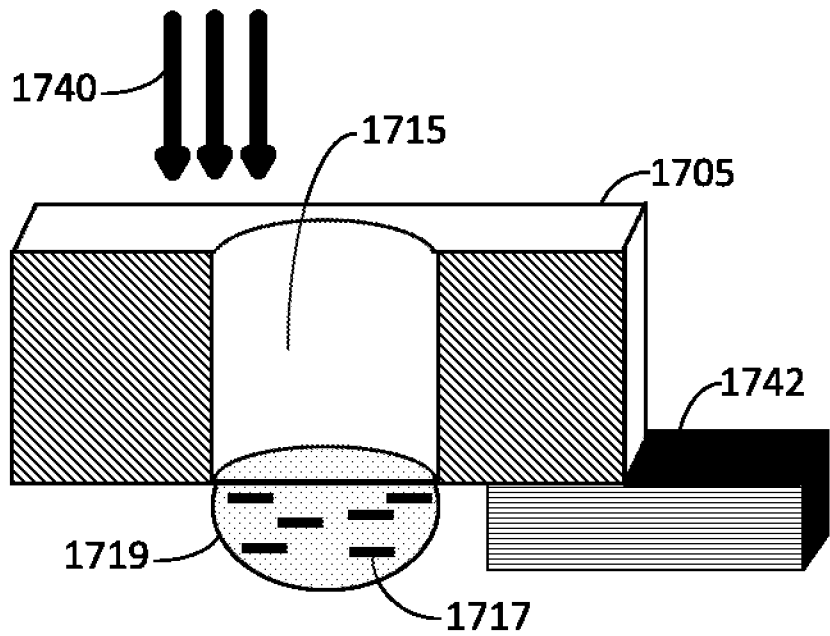

FIG. 17B

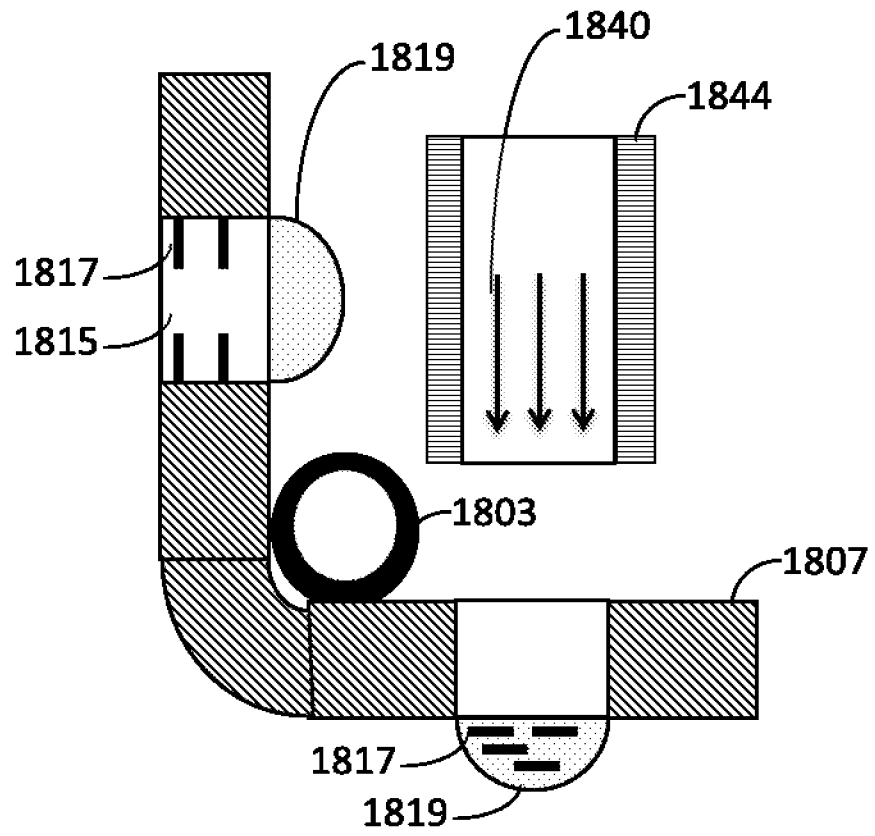

FIG. 18

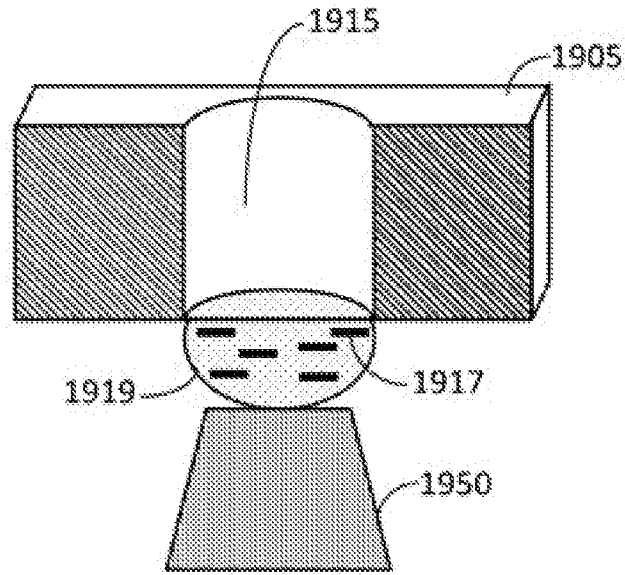

FIG. 19A

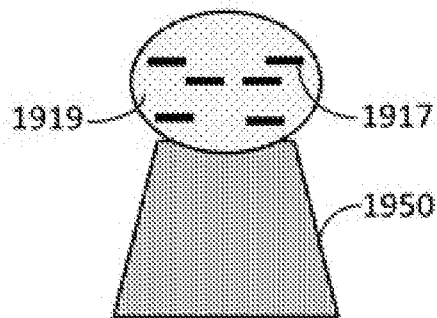
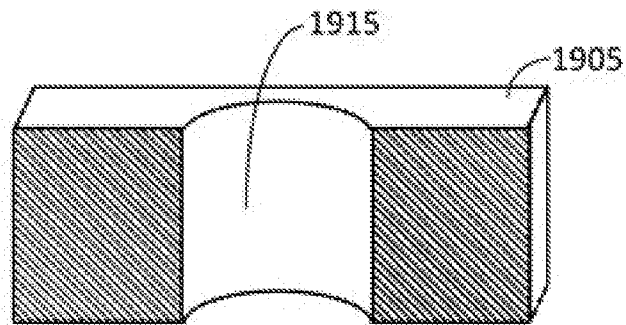

FIG. 19B

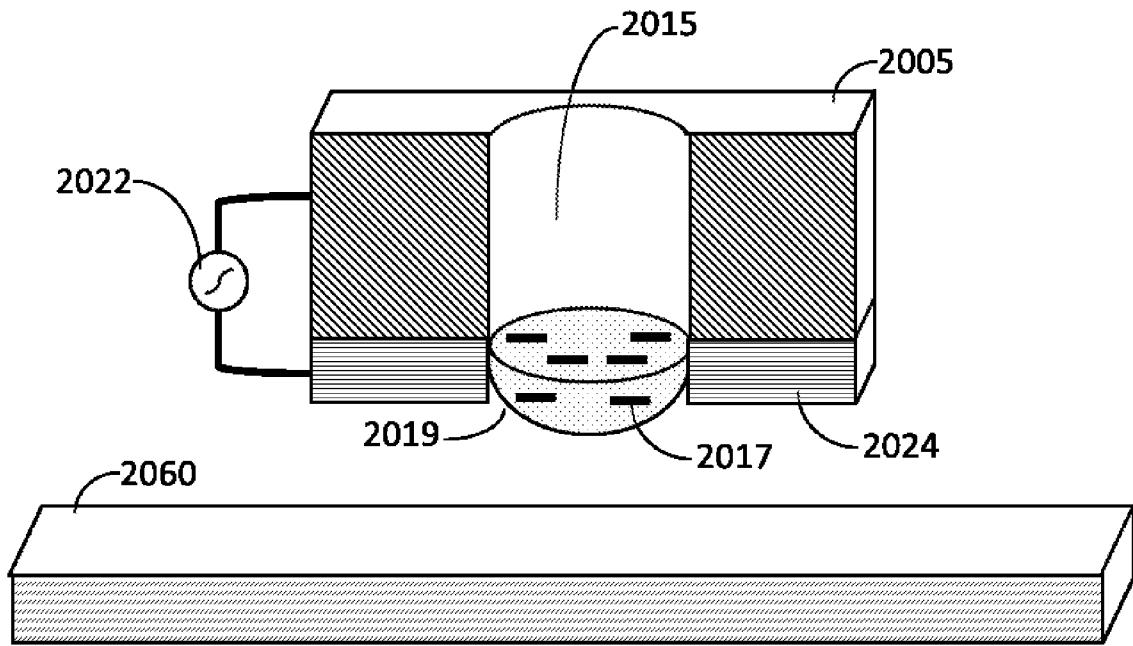

FIG. 20A

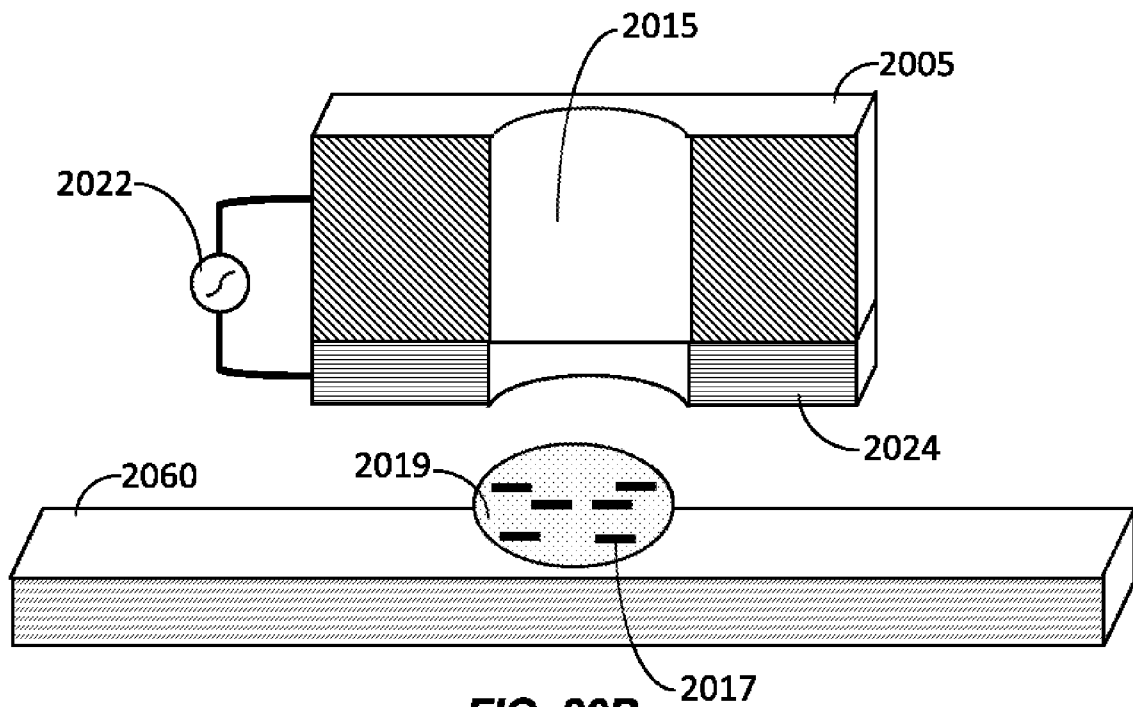

FIG. 20B

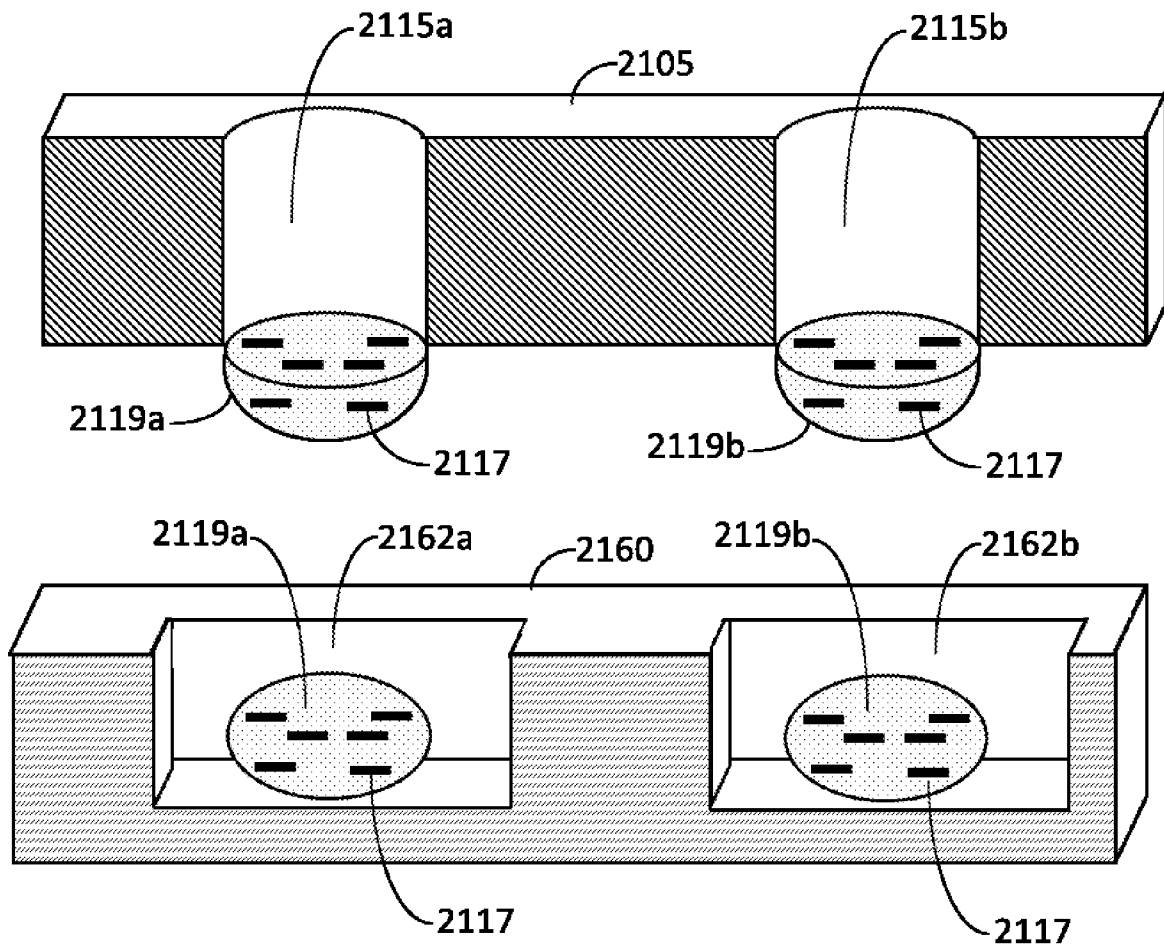

FIG. 21

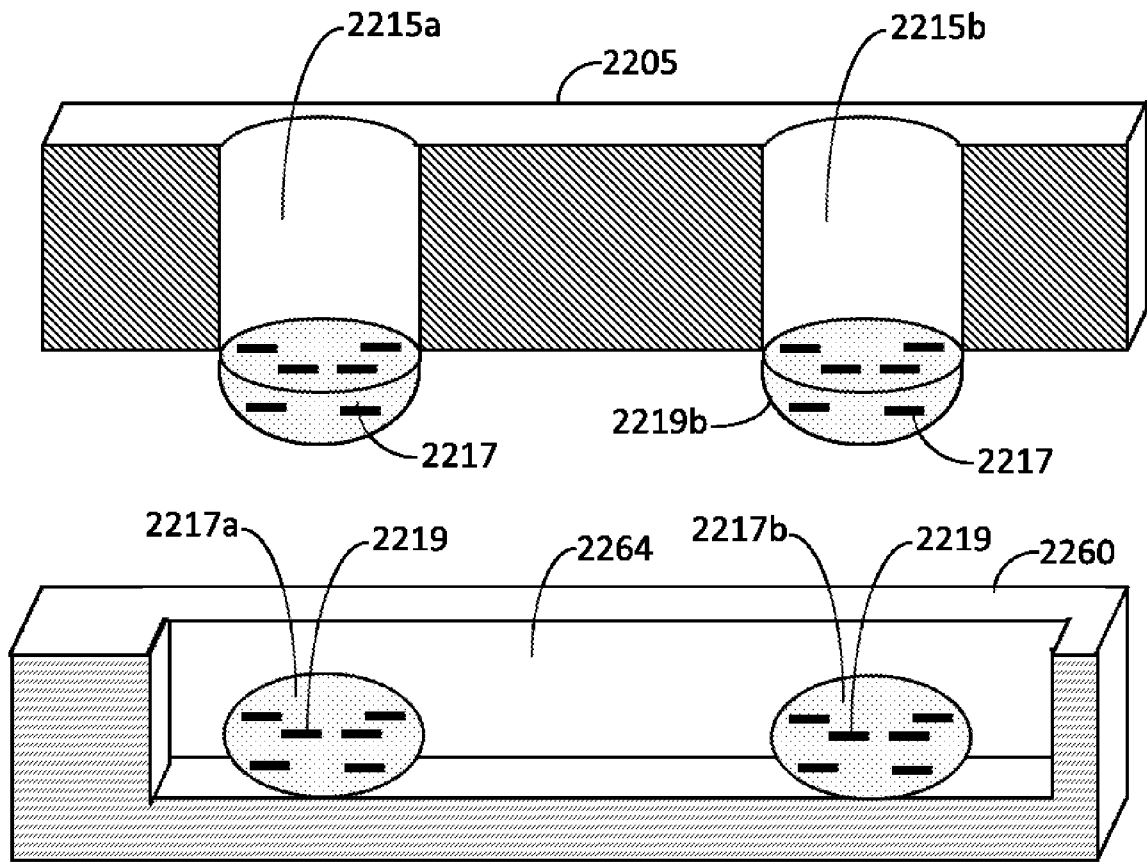

FIG. 22

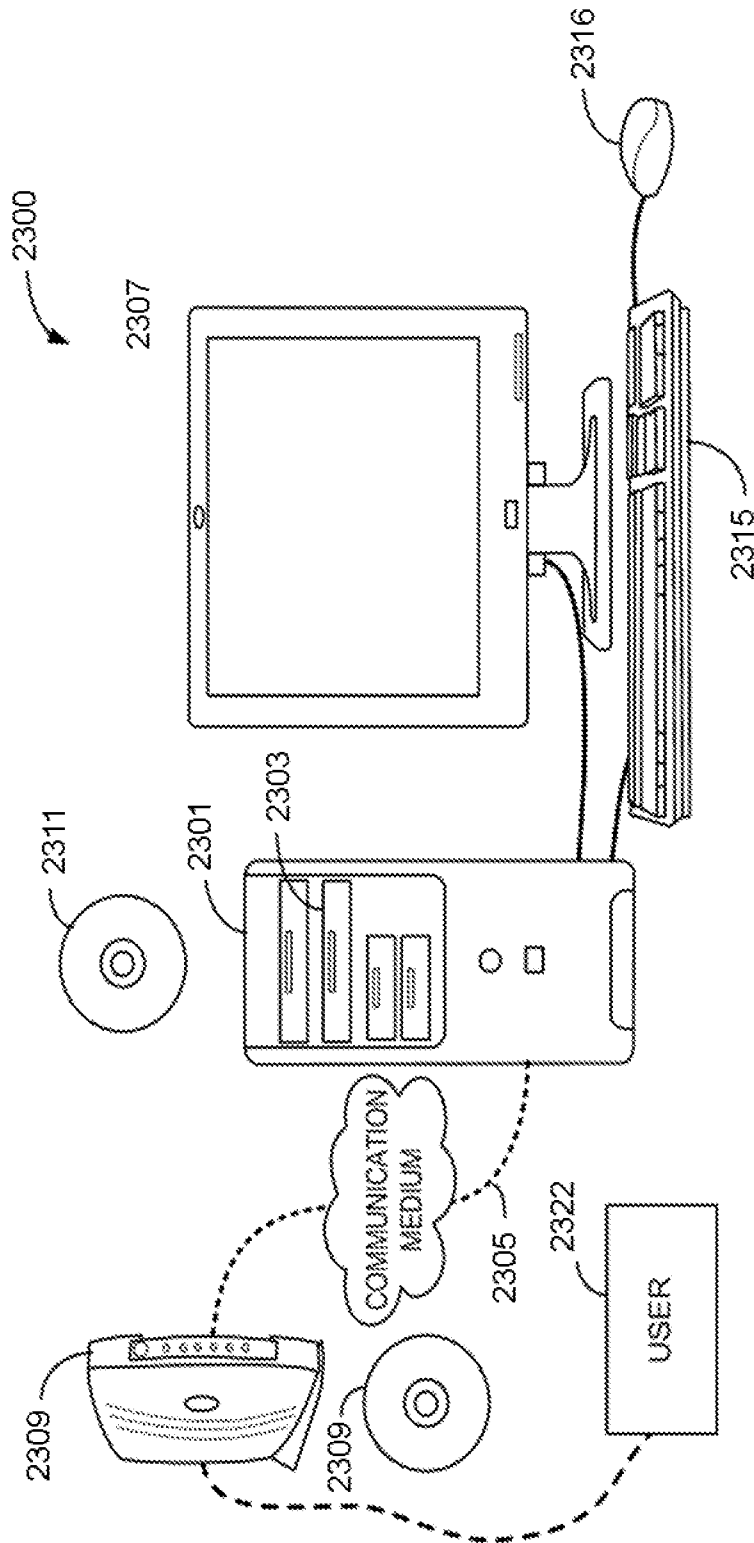

FIG. 23

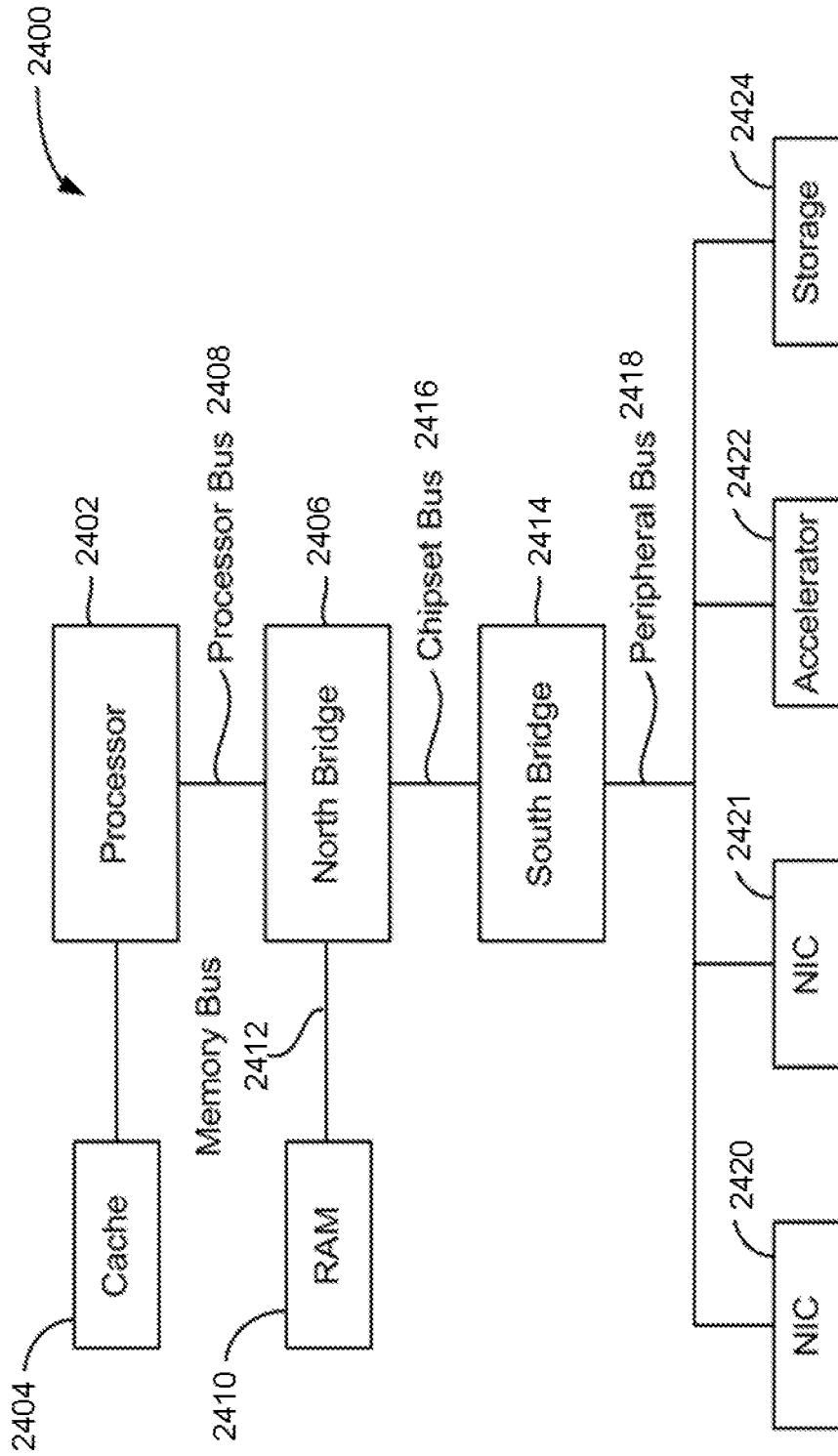

FIG. 24

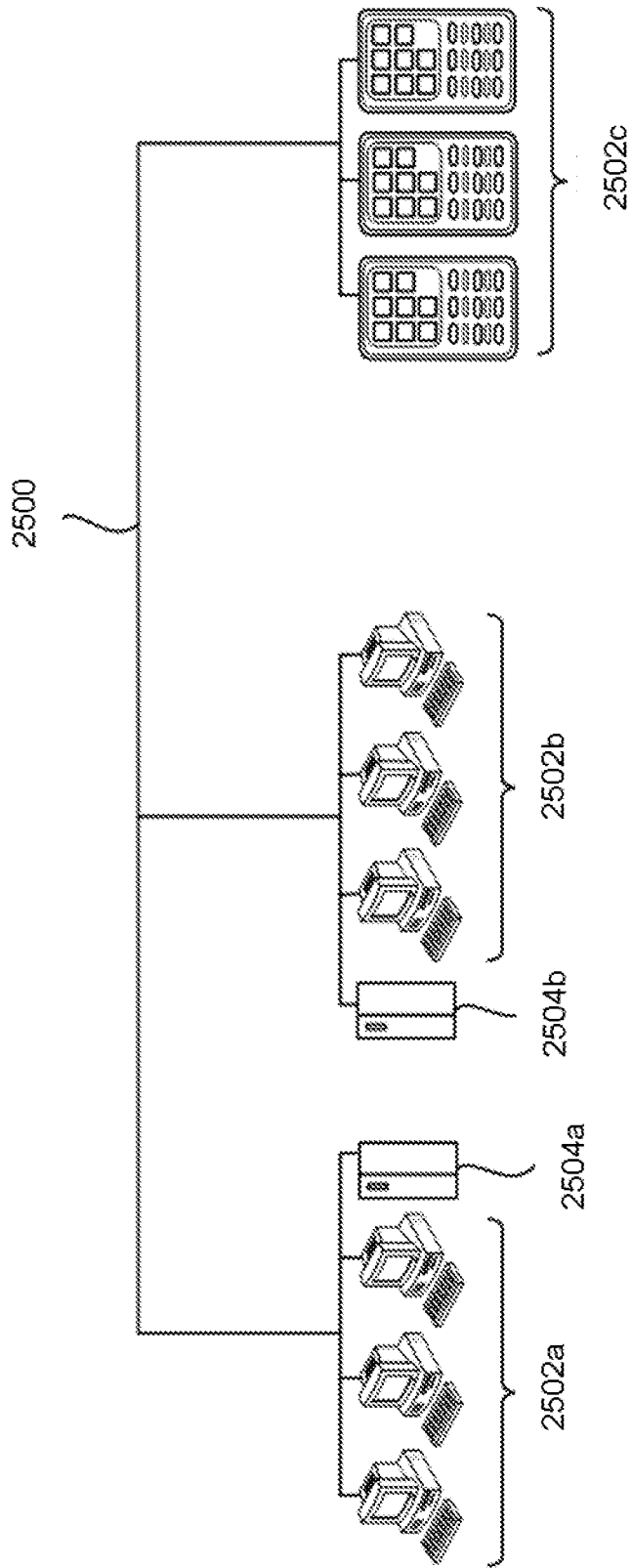

FIG. 25

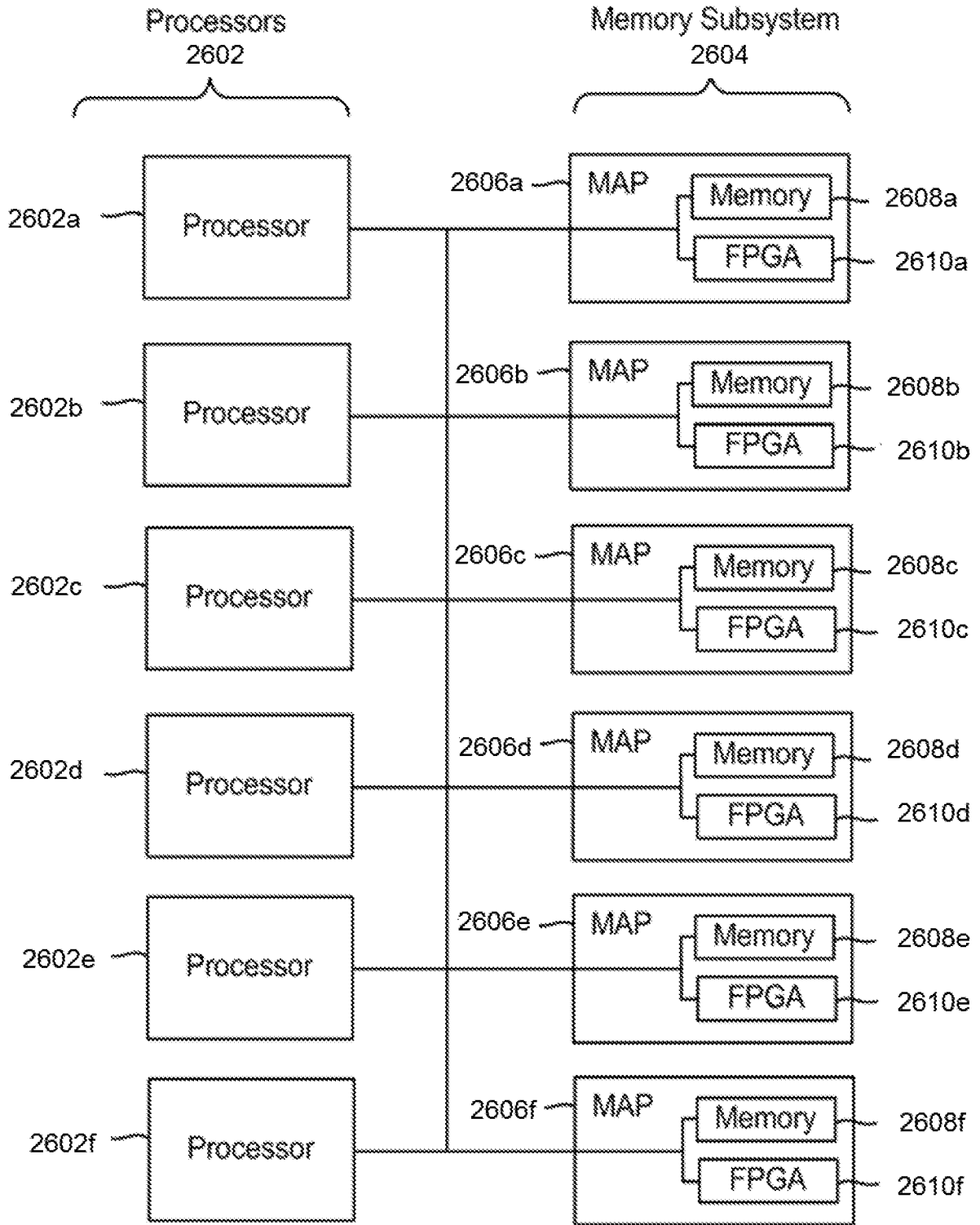

FIG. 26