

(19) World Intellectual Property Organization
International Bureau



(43) International Publication Date
15 January 2009 (15.01.2009)

PCT

(10) International Publication Number
WO 2009/009443 A1

- (51) International Patent Classification:
A61B 18/14 (2006.01) A61N 5/00 (2006.01)
- (21) International Application Number:
PCT/US2008/069243
- (22) International Filing Date: 3 July 2008 (03.07.2008)
- (25) Filing Language: English
- (26) Publication Language: English
- (30) Priority Data:
60/958,543 6 July 2007 (06.07.2007) US
- (71) Applicant (for all designated States except US): **BARRX MEDICAL, INC.** [US/US]; 540 Oakmead Parkway, Sunnyvale, CA 94085 (US).
- (72) Inventors; and
- (75) Inventors/Applicants (for US only): **UTLEY, David, S.** [US/US]; 3725 Jefferson Court, Redwood City, CA 94062 (US). **CSEPEL, John de** [US/US]; 540 Oakmead Parkway, Sunnyvale, CA 94086 (US).

- (74) Agents: **COHEN, David, C.** et al.; Shay Glenn LLP, 2755 Campus Drive, Suite 210, San Mateo, CA 94403 (US).
- (81) Designated States (unless otherwise indicated, for every kind of national protection available): AE, AG, AL, AM, AO, AT, AU, AZ, BA, BB, BG, BH, BR, BW, BY, BZ, CA, CH, CN, CO, CR, CU, CZ, DE, DK, DM, DO, DZ, EC, EE, EG, ES, FI, GB, GD, GE, GH, GM, GT, HN, HR, HU, ID, IL, IN, IS, JP, KE, KG, KM, KN, KP, KR, KZ, LA, LC, LK, LR, LS, LT, LU, LY, MA, MD, ME, MG, MK, MN, MW, MX, MY, MZ, NA, NG, NI, NO, NZ, OM, PG, PH, PL, PT, RO, RS, RU, SC, SD, SE, SG, SK, SL, SM, ST, SV, SY, TJ, TM, TN, TR, TT, TZ, UA, UG, US, UZ, VC, VN, ZA, ZM, ZW.
- (84) Designated States (unless otherwise indicated, for every kind of regional protection available): ARIPO (BW, GH, GM, KE, LS, MW, MZ, NA, SD, SL, SZ, TZ, UG, ZM, ZW), Eurasian (AM, AZ, BY, KG, KZ, MD, RU, TJ, TM), European (AT, BE, BG, CH, CY, CZ, DE, DK, EE, ES, FI, FR, GB, GR, HR, HU, IE, IS, IT, LT, LU, LV, MC, MT, NL, NO, PL, PT, RO, SE, SI, SK, TR), OAPI (BF, BJ, CF, CG, CI, CM, GA, GN, GQ, GW, ML, MR, NE, SN, TD, TG).

Published:
— with international search report

(54) Title: METHOD AND APPARATUS FOR GASTROINTESTINAL TRACT ABLATION TO ACHIEVE LOSS OF PERSISTENT AND/OR RECURRENT EXCESS BODY WEIGHT FOLLOWING A WEIGHT-LOSS OPERATION

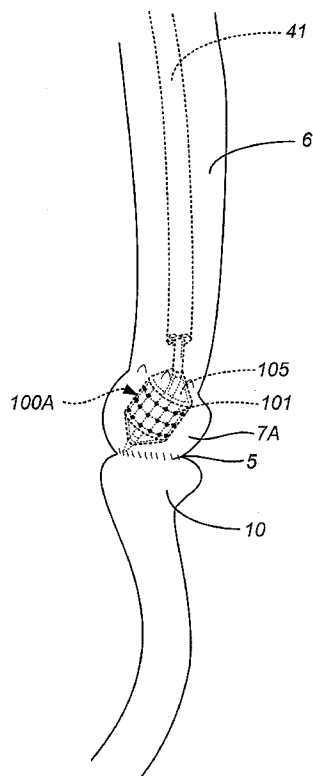

FIG. 1A

(57) Abstract: Devices and methods are provided for ablational treatment of regions of the digestive tract in post-bariatric surgery patients who fail to achieve or maintain the desired weight loss. Bariatric procedures include Roux-en-Y gastric bypass, biliopancreatic diversion, and sleeve gastrectomy. These procedures reconstruct gastrointestinal tract features, creating pouches, stoma, and tubes that restrict and/or divert the digestive flow. Post-surgical dilation of altered structures is common and diminishes their bariatric effectiveness. Ablation of compromised structures can reduce their size and compliance, restoring bariatric effectiveness. Ablation, as provided the invention, starts at the mucosa and penetrates deeper into the gastrointestinal wall in a controlled manner. Control may also be provided by a fractional ablation that ablates some tissue within a target region and leaves a portion substantially unaffected. Embodiments of the device include an ablational electrode array that spans 360 degrees and an array that spans an arc of less than 360 degrees.

WO 2009/009443 A1

**METHOD AND APPARATUS FOR GASTROINTESTINAL TRACT ABLATION TO
ACHIEVE LOSS OF PERSISTENT AND/OR RECURRENT EXCESS BODY WEIGHT
FOLLOWING A WEIGHT-LOSS OPERATION**

CROSS REFERENCE TO RELATED APPLICATIONS

[001] This application claims priority to US Provisional Patent Application No. 60/958,543, filed on July 6, 2007, entitled "Non-Barrett's Mucosal Ablation and Tissue Tightening Indications Related to Obesity" by David S. Utley.

[002] This application incorporates in entirety commonly assigned US Patent Application Ser. No. 10/370,645 entitled "Method of Treating Abnormal Tissue in the Human Esophagus", filed on February 19, 2003, and published as US 2003/0158550 on August 21, 2003, and US Patent Application Ser. No. 11/286,444 entitled "Precision Ablating Method", filed on November 23, 2005, and published as US 2007/0118106 on May 24, 2007. Further, each of the following commonly assigned United States Patent Applications are incorporated herein by reference in its entirety: Patent Application Ser. No. 10/291,862 titled "Systems and Methods for Treating Obesity and Other Gastrointestinal Conditions," Patent Application Ser. No. 10/370,645 titled "Method of Treating Abnormal Tissue In The Human Esophagus," Patent Application Ser. No. 11/286,257 titled "Precision Ablating Device," Patent Application Ser. No. 11/275,244 titled "Auto-Aligning Ablating Device and Method of Use," Patent Application Ser. No. 11/286,444 titled "Precision Ablating Device," Patent Application Ser. No. 11/420,712 titled "System for Tissue Ablation," Patent Application Ser. No. 11/420,714 titled "Method for Cryogenic Tissue Ablation," Patent Application Ser. No. 11/420,719 titled "Method for Vacuum-Assisted Tissue Ablation," Patent Application Ser. No. 11/420,722 titled "Method for Tissue Ablation," Patent Application Ser. No. 11/469,816 titled "Surgical Instruments and Techniques for Treating Gastro-Esophageal Reflux Disease." This application further incorporates in entirety US Patent Application Ser. No.10/291,862 of Utley, filed on November 8, 2002 entitled "Systems and Methods for Treating Obesity and Other Gastrointestinal Conditions, and published on May 13, 2004 as US 2004/0089313, and US Patent No. 7,326,207 of Edwards, entitled "Surgical Weight Control Device", which issued on February 5, 2008. This application further incorporates in entirety US Patent Application Ser. No. 12/114,628 of Kelly *et al.* entitled "Method and Apparatus for Gastrointestinal Tract Ablation for Treatment of Obesity", as filed on filed May 2, 2008. This application further incorporates in entirety US Patent Application Ser. No. 12/143,404, of Wallace, Garabedian, and Gerberding, entitled "Electrical Means to Normalize Ablational Energy Transmission to a Luminal Tissue Surface of Varying Size", as filed on June 20, 2008.

INCORPORATION BY REFERENCE

[003] All publications, patents and patent applications mentioned in this specification are herein incorporated by reference to the same extent as if each individual publication, patent or patent application was specifically and individually indicated to be incorporated by reference.

FIELD OF THE INVENTION

[004] The present invention relates to endoscopic therapy devices and methods, such as devices and methods to treat areas of the digestive tract in overweight and obese patients who have undergone weight loss surgery (bariatric surgery), yet failed to achieve or maintain the desired excess body weight loss.

BACKGROUND OF THE INVENTION

[005] Obesity can lead to a number of life-threatening and morbidity-producing disease states such as diabetes mellitus, heart disease, vascular disease, osteoarthritis, gout, and obstructive sleep apnea. Body mass index [$\text{kg body mass} / (\text{meters height})^2$] is used as a measure of obesity; a patient with a BMI of 25.0 – 29.9 kg/m^2 is considered overweight, while a BMI greater than 30.0 kg/m^2 considered obese. If diet and exercise are unsuccessful in achieving or maintaining an optimal or ideal body weight, and if the patient has a BMI greater than 40 kg/m^2 (or a BMI greater than 35 kg/m^2 with coexisting morbid conditions), a bariatric surgical procedure may be performed to induce weight loss. Bariatric surgeries are generally categorized as having a restrictive effect, a malabsorptive effect, or both effects. A restrictive effect refers to creating a surgical constriction at the area where food exits the esophagus or proximal stomach and/or reducing the size of the stomach, which acts a food reservoir. By restricting exit of food from the esophagus and proximal stomach and by restricting the size and/or compliance of the stomach, the stomach (or its remnant) fills with a small amount of food and the patient experiences early fullness or satiety. Such an effect either makes it uncomfortable to eat additional food or diminishes appetite (induces satiety). A malabsorptive effect refers to changing the digestive tract anatomy so that absorption of nutrients from food intake is limited or altered in some manner and/or the intake of excessive amount of food causes the patient to have adverse symptoms. In addition to these effects of bariatric surgery that are related to surgically altered digestive tract anatomy, other effects on endocrine and neural systems that include the gastrointestinal tract have also been recently appreciated as having significant anti-obesity or anti-diabetic effects (see U.S. Patent Application No. 12/114628 of Kelly *et al.*, filed May 2, 2008).

[006] The most common bariatric surgical procedure performed is the Roux-en-Y gastric bypass (RGB), which is considered both a restrictive and malabsorptive procedure. Other techniques, performed less commonly, include sleeve gastrectomy and biliopancreatic diversion (BPD). Each operative technique has a physiological effect that is related to the post-surgical reconstructed anatomy. An anatomical structure common to the RGB and BPD is a small pouch at the end of the esophagus, formed from a portion of the proximal stomach and then connected in a new manner to a

portion of the small intestine via a structure known as a stoma (typically a gastro-jejunostomy stoma). Similarly, the sleeve gastrectomy permanently removes a large portion of the body of the stomach, creating a narrow tubular stomach that empties into the small intestine. The pouch and stoma of the RGB and BPD, as well as the tube of the sleeve gastrectomy, all restrict the flow of food passage from the esophagus to the rest of the digestive tract, thus causing a sensation of early fullness or satiety. Further, while the stomach can hold large amounts of food, the capacity of the surgically-formed gastric pouch or sleeve is quite limited, and thus the patient cannot take in large quantities of food and liquids due to a low reservoir capacity. Malabsorption is also an important effect of bariatric surgical procedures, which contributes to cause weight loss, in addition to the restrictive effects of these procedures.

[007] The reported effectiveness of RGB and other such operations is quite high, with patients losing an average of 60-70% of their excess body weight within about one year. Excess body weight is the amount of body mass above the ideal body weight for a patient, while excess body weight loss is the percentage of the excess body weight that is lost as a result of the surgical intervention for a patient. A successful bariatric surgical procedure is considered one in which the patient achieves > 50% excess body weight loss. Some patients fail to ever achieve a 50% excess body weight loss at any time after surgery, although this represents the minority of patients. Within the initial surgical successes, approximately 25% of patients regain all or a significant portion of the previously lost weight and are then considered surgical failures. The reasons for weight regain may include dilation of the pouch and/or stoma in the case of the RGB and BPD, while in gastric sleeve resection patients the newly tubularized stomach may dilate. In all three scenarios, more food is able to be stored in the pouch and tubularized stomach due to dilation, therefore early satiety is not achieved, and the food may pass more quickly into the small intestine, therefore making more room for more food to be eaten. Dilation can be observed in endoscopic examination where the structure appears visibly larger in one or more dimensions, specifically inner diameter, than the ideal size achieved at prior surgery. Dilation can result from an increase in compliance or distensibility of the structure, which is not detectable on endoscopic examination. Increased compliance of the pouch/tube will allow the structure to stretch to accommodate more food and liquid, while increased compliance of the stoma will allow food and liquid to pass more readily. In both cases, there is a loss of the sensation of early satiety which allows the person to take in larger quantities of food and liquid at more frequent intervals, thus resulting in regain of weight.

[008] For patients that have undergone a bariatric surgical procedure and have regained some or all of their excess body weight, the options for additional therapy to re-achieve weight loss are very limited. A repeat surgical procedure to revise the altered gastrointestinal anatomy carries a very high risk for surgical morbidity and mortality. Such revision surgical procedures might alter the pouch and stoma, or might alter the gastric tube, but with uncertain results. These types of revisional procedures

are not commonly performed due to patient risk. Others have attempted a non-surgical, endoscopic revision procedure with the placement of endoscopic suture material and other such mechanical structures to reduce the size of the pouch/stoma and gastric tube, although these are temporary interventions. When the suture or structure falls out or is absorbed by the body, the previously dilated anatomy may recur and weight gain return. Therefore, a viable, non-surgical, endoscopic device and method which would result in a permanent alteration of the stoma/pouch and gastric sleeve which would reduce the size and/or compliance of the structure(s), would be desirable.

SUMMARY OF THE INVENTION

[009] The present invention provides various embodiments of an endoscopic therapeutic device and method to achieve a permanent physiological alteration of the stoma/pouch and gastric sleeve in a previously operated patient after Roux-en-Y gastric bypass (RGB), biliopancreatic diversion BPD), or gastric sleeve resection for overweight and obese indications, in order to reduce the size and/or compliance of the structure(s) and re-establish weight loss and ideal body weight for the patient. Rather than relying on foreign body material, such as suture and staples, to achieve this permanent alteration, the disclosed devices and methods alters the anatomy with ablative therapy thus allowing the body's healing processes to incur a change in size, shape, and compliance to re-establish weight loss. To this end, the device includes an endoscopic catheter that is either balloon-based or not balloon-based, and, is mounted on the end of an endoscope, passes through a working channel or accessory channel of an endoscope, or passes along side an endoscope. The device has an energy delivery element, such as an electrical array, on at least one surface to deliver ablational energy from a source to the targeted tissue in a manner so that the depth of ablation is controlled via parameters such as energy density, electrode pattern, power density, number of applications, and pressure exerted on the tissue. The catheter is supplied with ablation energy by an energy generator, connected to the catheter with a cable.

[0010] The method includes using the devices described, typically in conjunction with an endoscope for visualization, to visualize gastrointestinal features that have been formed, altered, or reconstructed by bariatric surgery, positioning the device in one or more locations with the described structures, deploying the device so as to make therapeutic contact with the described structures, and delivering ablative energy one or more times. Treatment parameters may be such that a uniform level of ablation is achieved in all or part of the structure. For example, the entire epithelium can be removed from the structure, without injury to deeper layers of the structure, thus resulting in healing in a narrowed and/or less compliant state over time. Another example is to apply energy in a uniform manner to incur a deeper injury, including the deep mucosa and submucosa, with attendant heating of connective tissue, collagen-rich tissue in particular, heat mediated contraction of those structures and shrinkage of the structure. The method may include more than one mechanism of action, such as

epithelial layer partial or complete removal, as well as heat-mediated tissue contraction. All mechanisms of action result in a reduction of the size of the treated structure, both immediately and over a longer time course, and/or a reduction in compliance of the structure (immediately and over time), with the desired result of re-establishing and maintaining weight loss for the patient.

[0011] A number of ablation devices are provided as examples of embodiments that provide either fully-circumferential or partially-circumferential ablation surfaces. These, however, are merely examples and other embodiments that are consistent with the characterization of having fully-circumferential or partially-circumferential ablation surfaces are included as embodiments. Further, the effects of ablation on features of a gastrointestinal tract that have been formed by a bariatric surgery that are described in the context of one particular embodiment of the invention are generally intended to apply to the effects as achieved by any embodiment. Further still, the fractionally-ablating radiofrequency electrode patterns or associated methods of operating them may be applied to any embodiment, regardless of whether the ablation surface is fully or partially circumferential.

[0012] The invention provides a system and methods for implementing the system to ablationally treat tissue in a target area of a gastrointestinal tract feature formed by a bariatric procedure that has failed in its objective of having a patient achieve loss of excess weight. Typically, such surgical failure includes the dilation of a feature formed by the weight loss therapy. The method includes delivering radiofrequency energy to a tissue surface in the target area (the target area being a contiguous radial portion of an anatomical structure formed or altered by the bariatric procedure) and controlling the delivery of radiofrequency energy across the tissue surface in the target area and into tissue layers in the target area. Exemplary bariatric procedures include any of a Roux-en-Y procedure, a biliopancreatic diversion, a sleeve gastrectomy, or any similar procedure. Exemplary features of a gastrointestinal tract formed by bariatric procedure include any of a gastric pouch, a stoma, or a gastric sleeve. A particular exemplary feature may include a suture or staple line of the gastric sleeve. An exemplary mode of delivering radiofrequency energy includes delivering radiofrequency energy from non-penetrating electrodes.

[0013] In some embodiments of the method, controlling the delivery of radiofrequency energy across the tissue surface in the target area includes delivering sufficient radiofrequency energy to achieve ablation in one fraction of the tissue target surface and delivering insufficient radiofrequency energy to another fraction of the surface to achieve ablation. In some of these embodiments, controlling the fraction of the target area surface that receives sufficient radiofrequency energy to achieve ablation includes configuring the electrode pattern such that some spacing between electrodes is sufficiently close to allow conveyance of a level of energy sufficient to ablate and other spacing between electrodes is insufficiently close to allow conveyance of the level of energy sufficient to ablate. In other embodiments, controlling the fraction of the target area surface that receives sufficient radiofrequency energy to achieve ablation includes operating the electrode pattern such that the

energy delivered between some electrodes is sufficient to ablate and energy sufficient to ablate is not delivered between some electrodes. In some embodiments of the method, the delivering energy step is performed more than once, as may be appropriate for treatment of the target site.

[0014] In some embodiments of the method, controlling the delivery of radiofrequency energy into tissue layers includes controlling the delivery of radiofrequency energy from the tissue surface such that sufficient energy to achieve ablation is delivered to some layers, particularly shallow layers, and insufficient energy is delivered to other layers, particularly deeper layers, to achieve ablation. In some embodiments controlling the delivery of radiofrequency energy across the surface and into tissue layers in the target area is such that some fraction of the tissue volume is ablated and another fraction of the tissue volume is not ablated. In more specific terms regarding the tissue layers being ablated, going from shallow to deep, controlling the delivery of energy into tissue layers may consist variously of ablating a fraction of tissue in the epithelial layer; ablating a fraction of tissue in the epithelial layer and the lamina propria, ablating a fraction of tissue in the epithelial layer, the lamina propria, and the muscularis mucosae; ablating a fraction of tissue in the epithelial layer, the lamina propria, the muscularis mucosae, and the submucosa; or ablating a fraction of tissue in the epithelial layer, the lamina propria, the muscularis mucosae, the submucosa, and the muscularis propria. More generally, controlling the delivery of radiofrequency energy across the tissue surface and into tissue layers can cause fractional ablation in tissue layers of the gastrointestinal tract.

[0015] In some embodiments of the method, delivering energy includes delivering energy from an electrode pattern configured circumferentially through 360 degrees around an ablation structure. In some of these embodiments, delivering energy from the ablation structure includes transmitting energy asymmetrically through the 360 degree circumference such that ablation is focused in an arc of less than 360 degrees. In other embodiments, delivering energy includes delivering energy from an electrode pattern configured circumferentially through an arc of less than 360 degrees around the ablation structure.

[0016] Some embodiments of the method may further include evaluating the target area at a point in time after the delivering energy step to determine the status of the area. The evaluating step may occur in close time proximity after the delivery of energy, to evaluate the immediate post-treatment status of the site. In various embodiments, the evaluating step occurs at least one day after the delivery of energy.

[0017] Some embodiments of the method may further include deriving energy for delivery to the target area from an energy source that is controlled by a control system. In some of the embodiments, the energy source is a generator. Various of these embodiments may further include feedback controlling the energy transmission so as to provide any of a specific power, power density, energy, energy density, circuit impedance, or tissue temperature.

[0018] Some embodiments of the method may further include advancing an ablation structure into the alimentary canal (wherein the non-penetrating electrode pattern is on the structure, and the structure is supported on an instrument); positioning the ablation structure adjacent to the target area; and moving the ablation structure toward the surface of the target area to make therapeutic contact on the target area prior to delivering energy. In various of these embodiments, the moving step may include any of inflating a balloon member, expanding a deflection member, moving a deflection member, or expanding an expandable member.

[0019] In some embodiments of the method, following the moving step, the method may include a position-locking step following the moving step; an exemplary position-locking step may include developing suction between the structure and the ablation site.

[0020] In some embodiments of the method, prior to the positioning step, may include evaluating the target area in order to determine the status of the target area.

[0021] Some embodiments of the method include treating multiple target areas, in which case the method may include the positioning, moving, and transmitting energy steps to a first target area, and then further include directing the positioning, moving, and transmitting energy steps to another target area without removing the ablation structure from the patient.

[0022] As mentioned at the outset of the summary, embodiments of the invention include an ablation system for treating a target area in tissue in a portion of a gastrointestinal tract formed by bariatric procedure. Such a system includes an electrode pattern including a plurality of electrodes; a longitudinal support member supporting the electrode pattern; a generator coupled to the plurality of electrodes; and a computer controller in communication with the generator. The controller has programming to direct the generator to deliver energy to the plurality of electrodes, the programming including the ability to direct delivery of energy to a subset of the electrodes, the electrodes of the pattern configured such that, when receiving energy from the generator and in therapeutic contact with a tissue target area, the electrodes ablate a portion of tissue in the target area and leave a portion of tissue in the target area non-ablated. Exemplary portions of the gastrointestinal tract formed or altered by the bariatric procedure include any of a gastric pouch, a stoma, or a gastric sleeve

[0023] In some embodiments of the ablation system, the electrode pattern, having a longitudinal axis aligned with the endoscope or the supporting delivery catheter, forms a fully circumferential surface orthogonal to its longitudinal axis, the pattern sized for contacting tissue in a target area in the gastrointestinal tract. In other embodiments, the electrode pattern forms a partially circumferential surface orthogonal to its longitudinal axis, the pattern being appropriately sized for contacting tissue in a target area in the gastrointestinal tract. In various of these latter embodiments, the electrode pattern forms an arc of about 180 degrees, and in other embodiments, the electrode pattern forms an arc of about 90 degrees.

[0024] In some embodiments of the ablation system, electrode elements are distributed into a pattern such that when the programming directs the generator to deliver energy to all the electrodes, the electrode pattern, when therapeutically contacted to a target tissue area, ablates a portion of tissue in the target area and does not ablate another portion of tissue in the target area. In other embodiments, the programming directs the generator to deliver energy to a subset of electrode elements that form a pattern which, when therapeutically contacted to a target tissue area, ablates a portion of tissue in the target area and does not ablate another portion of tissue in the target area. By either approach, using all of the electrodes of a fractional distribution, or using a portion of the electrodes that are distributed into a fractional pattern, the system can effect an ablation wherein the portion of tissue which is ablated is rendered at least partially dysfunctional, and wherein the portion of the tissue which is not ablated retains its functionality.

[0025] Some embodiments of the invention include an ablation system for treating targeted tissue in a target area of a gastrointestinal tract feature formed by a bariatric procedure that has failed. Such a system may include an ablation structure supported by an instrument, an electrode pattern on the ablation support structure, the electrode pattern configured to control the delivery of energy to a target tissue such that a portion of the surface of the target area receives sufficient radiofrequency energy to achieve ablation and another portion of the surface of the target receives insufficient energy to achieve ablation; and a means supported by the instrument by which to bring the ablation structure to gain therapeutic contact with tissue at the target area.

[0026] In another aspect of the therapeutic method provided herein, the method is one of non-surgically treating a gastrointestinal tract feature formed by a bariatric surgical procedure that has become dilated or overly-compliant. Such method includes identifying a target area of the surgically-formed gastrointestinal feature, positioning a therapy device in the gastrointestinal tract adjacent to a target area on the dilated feature, and performing a non-surgical reduction therapy on the target area of the dilated feature. In some embodiments, the identifying step is performed endoscopically. And in some embodiments, the identifying step, the positioning step, and the performing step are all conducted during a single endoscopic procedure. Embodiments of the method may further include inserting an instrument having a reduction therapy device mounted thereon into the gastrointestinal tract before the identifying step, and removing the instrument after the performing step.

[0027] Embodiments of this method of performing the non-surgical reduction therapy on the surgically-formed gastrointestinal feature may include applying energy, such as radiofrequency energy to the target area. Further, the application of energy may include applying energy more than once, and it may include applying energy to more than one site on the gastrointestinal feature during a treatment, or in multiple sessions of treatment. Per embodiments of the invention, applying energy also may include controlling the delivery of energy across the tissue surface in the target area, and it may also include controlling the depth of delivery of energy into tissue layers in the target area.

[0028] Embodiments of this method of performing the non-surgical reduction therapy on the surgically-formed gastrointestinal feature, alternatively to radiofrequency energy, may include applying cryogenic treatment to the target area. In some of these embodiments, the cryogenic treatment includes spraying a cryogenic fluid on the target area, and in other embodiments, the cryogenic treatment includes drawing heat from the target area into a cryogenic fluid contained in the device

[0029] In some embodiments of the method, the positioning step may further include moving an ablation structure of the device so as to make therapeutic contact with a target area on the dilated feature. Exemplary ways of moving the ablation structure may include any of inflating a balloon member, expanding a deflection member, moving a deflection member, or expanding an expandable member.

BRIEF DESCRIPTION OF THE DRAWINGS

[0030] **Figures 1A – 1D** provide a view of a portion of a gastrointestinal tract that has been reconstructed by either a Roux-en-Y bypass procedure (RGB) or a biliopancreatic diversion (BPD); the view includes the esophagus, then proceeding distally, the gastroesophageal junction, a gastric pouch, a stoma or anastomosis between the gastric pouch and a portion of the small bowel, and a portion of the small bowel itself. **Figure 1A** shows an ablative device with a fully circumferential operating radius inserted into the gastric pouch, filling the lumen of the pouch.

[0031] **Figure 1B** shows an ablative device with a partially circumferential operating radius inserted into the gastric pouch, and positioned against a portion of the wall.

[0032] **Figure 1C** shows an ablative device with a fully circumferential operating radius inserted into the stoma, filling the lumen of the stoma.

[0033] **Figure 1D** shows an ablative device with a partially-circumferential operating radius inserted into the stoma and positioned against a portion of the stomal wall.

[0034] **Figures 2A – 2B** provide a view of a portion of a gastrointestinal tract that has been reconstructed by a sleeve gastrectomy. The esophagus and gastroesophageal junction are similar to that of the RGB or BPD procedures as seen in **Figures 1A – 1C**; the focus is on the gastric sleeve formed by suturing or stapling a tubular portion from the stomach, effectively removing the majority of the stomach from the digestive flow path for. **Figure 2A** shows an ablative device with a fully circumferential operating radius inserted into the gastric sleeve, filling the lumen of the sleeve.

[0035] **Figure 2B** shows an ablative device with a partially circumferential operating radius inserted into the gastric sleeve, and positioned against a portion of the wall of the sleeve.

[0036] **Figure 3** is a flow diagram depicting an overview of the method, wherein an appropriate site for ablational treatment of dilated feature of a gastrointestinal tract formed by bariatric surgery is determined, the level of ablational therapy is determined, and at least preliminary information is

gained regarding localization, and clinical judgment is exercised as to which embodiment of the invention is preferable.

[0037] **Figure 4** is a flow diagram depicting the method after the site of ablation of a portion of the bypass-reconstructed tract has been localized and a choice has been made regarding the preferred ablational device. The method includes an evaluation of the site, including particulars of location, stage, determination of the number of sites, and the dimensions. The method continues with insertion of the instrument and its movement to the locale of the ablational target tissue, the more refined movement of the ablational structure that create a therapeutically effective contact, the emission of ablational radiation and then post-treatment evaluation.

[0038] **Figure 5** is a view of an embodiment of an ablative device with a fully circumferential operating radius.

[0039] **Figure 6** is a view of an embodiment of an ablative device with a fully circumferential operating radius, with a balloon member in an expanded configuration.

[0040] **Figures 7A – 7C** show the electrode patterns of the device of **Figure 5**.

[0041] **Figures 8A – 8D** show electrode patterns that may be used with embodiments of the ablative device with a fully circumferential operating radius, or with any device embodiments described herein.

[0042] **Figure 9** is a view of the ablation device of the invention with a partially circumferential operating radius.

[0043] **Figure 10** is an end view of the ablation device embodiment of **Figure 9**.

[0044] **Figure 11** is an end view of the device of **Figure 9** in an expanded configuration.

[0045] **Figures 12, 13, and 14** are end views of the device of **Figure 9** in alternative expanded configurations:

[0046] **Figure 15** is a view of the ablation device of the invention in an unexpanded configuration.

[0047] **Figure 16** is a view of the ablation device of the invention in an expanded configuration.

[0048] **Figures 17 and 18** are end views of the device in an expanded configuration.

[0049] **Figure 19A** is a view of the ablation device of the invention showing a deflection member feature.

[0050] **Figure 19B** is a view of the ablation device of the invention showing an alternative deflection member wherein the device is in an expanded configuration.

[0051] **Figure 20** is a view of device shown in **Figure 19B** wherein the deflection member is in an unexpanded configuration.

[0052] **Figure 21** is an end view of the device in an unexpanded configuration.

[0053] **Figure 22** is an end view of the device shown in **Figure 21** in an expanded configuration.

[0054] **Figure 23** is a view of the ablation device of the invention showing a pivoting ablation structure feature.

- [0055] **Figure 24** is an illustration of the ablation device of the invention combined with an endoscope system.
- [0056] **Figure 25** is a schematic of view of a section through the wall of a representative organ of the bypass-reconstructed gastrointestinal tract, such as a gastric pouch, stoma or tubular portion.
- [0057] **Figure 26** is a view of the ablation device of the invention including an elongated sheath feature.
- [0058] **Figure 27** is a view of the device wherein an elongated sheath feature is optically transmissive.
- [0059] **Figure 28** is an enlarged view of the optically transmissive feature of the device.
- [0060] **Figure 29** is a cross sectional view of the optically transmissive sheath feature of the device shown in **Figures 27 and 28**.
- [0061] **Figure 30** is a view of the device including an alternative optically transmissive sheath feature and an inflation member feature in an expanded configuration.
- [0062] **Figure 31** is an illustration of the ablation device of **Figure 30** positioned within an esophagus.
- [0063] **Figure 32** is a view of the ablation device of the invention including a slit sheath feature.
- [0064] **Figure 33A** is an end view of a slit sheath feature of the device wherein the sheath is in an unexpanded configuration.
- [0065] **Figure 33B** is an end view of a slit sheath feature of the device and an endoscope wherein the sheath is in an expanded configuration.
- [0066] **Figure 34A** is a cross sectional view of the device positioned within an endoscope internal working channel wherein an inflatable member feature is in an unexpanded position.
- [0067] **Figure 34B** is a view of the device shown in **Figure 34A** wherein the inflatable member feature is in an expanded position.
- [0068] **Figure 35A** is a cross sectional view of the device positioned within an endoscope internal working channel wherein an expandable member feature is in an unexpanded position.
- [0069] **Figure 35B** is a view of the device shown in **Figure 35A** wherein the expandable member feature is in an expanded position.
- [0070] **Figure 36A** is a cross sectional view of the device positioned within an endoscope internal working channel wherein an alternative expandable member feature is in an unexpanded position.
- [0071] **Figure 36B** is a view of the device shown in **Figure 36A** wherein the expandable member feature is in an expanded position.
- [0072] **Figure 37** is a view of the ablation device of the invention including an alternative deflection member.

[0073] **Figure 38** is an illustration of the ablation device of the invention including an alternative deflection member positioned within the lumen of an organ of the bypass-reconstructed gastrointestinal tract in a non-deflected position.

[0074] **Figure 39** is an illustration of the device shown in **Figure 38** wherein the deflection member is in a deflected position.

[0075] **Figure 40** is a cross sectional view of the ablation device of the invention showing an internal coupling mechanism feature.

[0076] **Figure 41** is a cross sectional view of the ablation device of the invention showing an alternative internal coupling mechanism and a rolled sheath feature.

[0077] **Figure 42** is an illustration showing a cross sectional view of the ablation device of the invention positioned within the lumen of an organ of the bypass-reconstructed gastrointestinal tract.

[0078] **Figure 43** is an illustration of the ablation device of the invention positioned within an esophagus showing a rotational feature.

[0079] **Figure 44** is an illustration of the ablation device of the invention positioned within an esophagus showing a rotational feature combined with an inflation member in an expanded configuration.

[0080] **Figures 45A – 45C** are views of the ablation device of the invention showing alternative rotational features.

[0081] **Figure 46A** is a view of an endoscope.

[0082] **Figure 46B** is a view of the ablation device of the invention including a catheter feature.

[0083] **Figure 46C** is a view of a sheath feature of the device.

[0084] **Figure 47** is a view of the ablation device of the invention including the features shown in **Figures 46A – 46C** in an assembly.

[0085] **Figures 48A – 48D** show an electrode array with a striped pattern for a fractional ablation and the ablation patterns on tissue that can be made from such a pattern.

[0086] **Figures 49A and 49B** show an electrode array with a concentric-circle pattern for a fractional ablation and the ablation patterns on tissue that can be made from such a pattern.

[0087] **Figures 50A and 50B** show an electrode array with a checkerboard pattern for a fractional ablation and the ablation patterns on tissue that can be made from such a pattern.

[0088] **Figures 51A and 51B** show an electrode array with a checkerboard pattern operating in a non-fractional manner and the ablation pattern on tissue that is made from such an operating pattern.

[0089] **Figures 52A and 52B** show an electrode array with a checkerboard pattern operating in a fractional manner and the ablation pattern on tissue that is made from such an operating pattern.

[0090] **Figures 53A and 53B** show an electrode array with a striped pattern of alternating positive and negative electrodes operating in a non-fractional manner and the ablation patterns on tissue that can be made from such an operating pattern.

[0091] **Figures 54A and 54B** show an electrode array with a striped pattern of alternating positive and negative electrodes operating in a fractional manner and the ablation patterns on tissue that can be made from such an operating pattern.

[0092] **Figure 55** shows a schematic rendering of a three-dimensional view of a target region of a radial portion of a bypass-reconstructed gastrointestinal wall after it has been ablationally treated.

[0093] **Figure 56A and 56B** provide views of an ablational device (similar to the devices of **Figures 38 and 39**) but including an ablational surface on a hinge structure or deflecting mechanism similar to that depicted in **Figure 43**, the hinge allowing a free pivoting movement of the ablational surface between its longitudinal axis and the longitudinal axis of an endoscope. **Figure 56A** shows the device with the ablational surface oriented in parallel with the endoscope. **Figure 56B** shows the device with the longitudinal axis of the ablational surface oriented at about a right angle with respect to the longitudinal axis of the endoscope.

[0094] **Figure 57A- 57D** provide perspective views of an ablation device with a 360 degree circumferential ablation surface on an overlapping electrode support furled around an expandable balloon, the operative element including a balloon and an electrode support in an expanded state. **Figure 57A** shows the support pulled away from the balloon to clarify that a portion of the support and an edge is adherent to the balloon, and another portion and its edge is not connected to the balloon.

[0095] **Figure 57B** shows the operative element of the device with the non-adherent portion of the support furled around the balloon in a deployable configuration, the non-adherent portion and its edge overlapping around the adherent portion.

[0096] **Figure 57C** shows the device of **Figures 57A and 57B** with an optional feature of the operative element, one or more elastic bands wrapped around the electrode support.

[0097] **Figure 57D** shows the device of **Figure 57C** in a collapsed state, with balloon portion being uninflated (or deflated), this being the state of the device when it is being deployed into a lumen and being positioned at a target site, as well as the state of the device after delivering ablation energy and about to be removed from the lumen.

[0098] **Figures 58A – 58B** depict an embodiment of an ablation device that is adapted to present an ablational surface into a concave or inwardly tapered target site such as the pylorus. The device includes an ablational surface circumferentially arranged on the distal portion of an expandable member, the expandable member mounted around the distal end of an endoscope. **Figure 58A** shows the device in a deployed configuration.

[0099] **Figure 58B** shows the device with the expandable member in an unexpanded or collapsed state, as would be appropriate for deployment of the device to a target tapered surface, or as would be appropriate for removal from the ablational site.

DETAILED DESCRIPTION OF THE INVENTION

Ablation treatment of structures within the gastrointestinal tract that have been altered by a bariatric surgical procedure

[00100] U.S. Patent Application No. 12/114628 of Kelly *et al.*, filed May 2, 2008, provides methods and systems for the use of ablation at various sites in the gastrointestinal tract as a primary therapy for diabetes and morbid obesity. The present application provides methods and systems for ablation as a secondary, a rescue, or a salvaging therapy in the wake of a failed surgical approach to obesity such as may occur in Roux-en-Y gastric bypass, biliopancreatic diversion, and sleeve gastrectomy procedures. Each of these procedures reconstructs gastrointestinal tract structure to create new features, by variously creating, for example, a gastric pouch, a stoma, such as a gastrojejunal stoma, or a gastric sleeve that restrict and/or divert the digestive flow. These new or altered or reconstructed features of bariatric surgery may also be generally referred to as bypass-reconstructed portion of a gastrointestinal tract.

[00101] In general, structures formed or altered by bariatric surgeries are smaller or narrower than their natural predecessor structures; they thus hold less food, and allow passage of food or chyme at a slower rate. Smaller or narrower structures are stressed and stretched, as the patients habits and intake do not conform to the new physical realities of the gastrointestinal tract. Thus, in time, any portion of such surgically constructed features of a gastrointestinal tract may stretch or dilate, or lose its non-compliant quality, and in so doing, lose its effectiveness in achieving or maintaining weight loss. The patient may then regain excessive weight and be considered a surgical failure. As described herein however, ablation of portions of bypass-reconstructed features can restore bariatric effectiveness.

[00102] Ablation, particularly well-controlled ablation, as provided herein, can have any one or more of several effects that can restore or implement effectiveness of the surgical anatomy in achieving additional weight loss, such as by stricturing or tightening of a lumen or stoma, diminishing compliance, or dampening peristaltic motility. Some bariatric procedures, such as a sleeve gastrectomy, form new structures that have an extended site of suturing or stapling that represent sites of weakness or vulnerability. These sites, in particular, can benefit from therapeutic ablation that creates a healing or scarring response that tightens the treated area and prevents further stretching. These objects of ablation in this therapeutic context are markedly different than the therapeutic objective, for example, of ablation in the esophagus to treat Barrett's esophagus. In that context, the object is to ablate a layer or population of cells that resides in the mucosal layer, but not to disturb the overall size or compliance of the esophagus, which would damage functionality of the organ and be harmful to the patient. In the present therapeutic context, reduction of lumen volume, and diminished stretchability of the luminal site is desirable. One embodiment or the method, for example, is to repeat ablation treatments so as to create areas of overlap, such overlapping areas having a particularly effective result in terms of creating luminal stricture and reducing the ability of the lumen to expand.

Longitudinally overlapping treatment sites can create undulating or corrugated-like areas along the length of the surgically formed or altered organ where stricture or non-compliant stiffness is particularly pronounced. The creation of such areas of particular stricture and non-compliance may provide overall benefit to the patient in terms of achieving the desired weight-loss effect.

[00103] A number of embodiments of ablation devices are provided herein, which may be described as having an ablational surface that spans either a 360-degree circumference, or some fractional portion of a full circumference around the device. For example, some devices have an ablational surface that spans about 180 degrees, and others have an ablational surface that spans about 90 degrees. The use of such ablation devices to create ablational effects that are directed toward restoring or improving the effectiveness of bariatric surgical results will be described in detail below in detail.

[00104] **Figures 1A – 1D** provide a view of a portion of a gastrointestinal tract that has been reconstructed by either a Roux-en-Y bypass procedure (RGB) or a biliopancreatic diversion (BPD); the view includes the esophagus, then proceeding distally, the gastroesophageal junction, a gastric pouch **7A**, a stoma or anastomosis **8** between the gastric pouch and a portion of the small bowel, and a portion of the small bowel itself. In **Figures 1A – 1D and 2A – 2B**, an ablation device of one of two types, **100A** (with an ablational surface of 360 degrees) or **100B** (with an ablational surface of less than 360 degrees, such as the approximate 90 degree embodiment shown) is supported on an ablation catheter **41**. The ablation device (**100A or 100B**) includes an ablation structure **101**. In an embodiment where the ablation is RF-based, the ablation device typically includes an array of electrodes depicted in further detail in other figures, and an inflation member or balloon **105**.

[00105] **Figure 1A** shows an ablative device **100A** with a fully circumferential operating radius inserted into the gastric pouch, filling the lumen of the pouch. The ablative device is supported on the distal end of an elongated shaft **41** of an instrument, has been inserted into the alimentary tract by an oral or nasal entry route, and has been moved into the proximity of an area targeted for treatment. **Figure 1A** shows the ablative device having entered the bypass-reconstructed gastrointestinal tract orally, having entered the gastric pouch **7A** through the esophagus **6**. The device depicted is merely an exemplary illustration, and alternative devices are included as embodiments, however what these embodiments have in common is an ablational surface that spans a complete 360 degree circumference that is expandable through the use of an expandable member included in the device internal to the ablational surface. Several such representative embodiments are shown and further described below (**Figures 6, 57, and 58**) and described further below. Embodiments of the fully circumferential ablational surface are typically cylindrical in form, but embodiments can include circumferential ablational surfaces arranged on surfaces that depart from strict cylindrical, and become more ovalular or spherical, as shown in **Figures 58A and 58B**, with one or both of the (proximal or distal) ends being tapered. By way of further description of the ablational surface, it

includes ablational delivery elements such as non-penetrating radiofrequency electrodes, but other types of ablational energy elements are included as embodiments as well, and as described further below. Exemplary arrangements of radiofrequency electrodes are shown in **Figure 5, and 7 – 9**. Arrangements of energy delivery elements that create a fractional or partial ablation within a target area, as well as the ablation patterns they deliver to target tissue, are described further below, and depicted in **Figures 48 – 55**. Another feature shared by energy delivery element patterns provided herein is that although the ablation pattern is on a surface that may be pressed into therapeutic contact by an expandable member, the immediate surface upon which the energy delivery elements are arranged is substantially non-distensible, thus the density of elements across the surface remains constant.

[00106] **Figure 1B** shows an ablative device **100B** with a partially circumferential operating radius inserted into the gastric pouch **7A**, and positioned against a portion of the wall. The device depicted is merely an exemplary illustration, and alternative devices are included as embodiments. Described below, and depicted in **Figures 9 – 23, 26 – 47, and 56** are a number of embodiments that provide an ablational surface of less than a fully circumferential span. In terms of the circumference with respect to the device itself, some embodiments provide an ablational surface of about 90 degrees, some embodiments provide an ablational surface of about 180 degrees, however embodiments include any partially-circumferential span. As described above in the context of the fully circumferentially-ablating device of **Figure 1A**, ablational energy elements include radiofrequency electrodes, among others, and may be arranged on the surface in any pattern, including fractionally-ablating patterns. The radial portion of a bypass reconstructed gastrointestinal lumen site (such as a gastric pouch **7A**, a stoma **5**, or a gastric sleeve **7B**) that can be ablationally treated in any single transmission of radiant energy depends on the width of the electrode-covered ablational surface of the embodiment of the device, and the width or diameter of the luminal organ where the treatment site is located. The width of embodiments of the ablational surface, in absolute terms, is described in detail below. The arc of a curved treatment area can be anything less than 360 degrees, however it is typically less than 180 degrees, and more particularly may include a smaller radial expanse such as arcs of about 5 degrees, about 10 degrees, about 15 degrees, about 30 degrees, about 45 degrees, about 60 degrees, and about 90 degrees.

[00107] **Figure 1C** shows an ablative device **100A** with a fully circumferential operating radius inserted into the stoma **5**, filling the lumen of the stoma; and **Figure 1D** shows an ablative device **100B** with a partially-circumferential operating radius inserted into the stoma and positioned against a portion of the stomal wall **5**.

[00108] **Figures 2A – 2B** provide a view of a portion of a gastrointestinal tract that has been reconstructed by a sleeve gastrectomy. The esophagus and gastroesophageal junction are similar to that of the RGB or BPD procedures as seen in **Figures 1A – 1C**; the focus in **Figures 2A and 2B**,

however, is on the gastric sleeve **7B** formed by suturing or stapling a tubular portion from the stomach, leaving sutured line or remnant **8**, thereby removing the majority of the stomach from the digestive flow path for. **Figure 2A** shows an ablative device **100A** with a fully circumferential operating radius inserted into the gastric sleeve **7B**, filling the lumen of the sleeve. **Figure 2B** shows an ablative device **100B** with a partially circumferential operating radius inserted into the gastric sleeve **7B**, and positioned against a portion of the wall of the sleeve in the proximity of the remnant suture line **8**. In the description that follows below, the label **100** may generally be used to designate ablational devices, regardless of whether their ablational surface **101** is fully circumferential or partially circumferential.

[00109] Metabolic conditions such as obesity, diabetes mellitus type 2, and metabolic syndrome can become such a threat to the health of the patient that medical intervention beyond diets and life-style recommendations are indicated. One first line interventional approach is that of bariatric surgery, while another first-line interventional, as described in U.S. Patent Application No. 12/114,628 of Kelly *et al.*, filed May 2, 2008 is that of ablational therapy applied to specific sites in the gastrointestinal tract. As noted above, in the background, however, the results of gastric bypass procedures include a significant level of ultimate failure mixed into a prevailing level of general success. The applicability of therapeutic methods (**Figures 3 and 4**) provided herein relates to patients in whom a bypass procedure has failed or become unsatisfactory with regard to its ability to manage body weight control. Accordingly, ablation may be included as a secondary form of intervention in the event of bypass failure, such ablation being directed to specific sites within the surgically formed or surgically-altered structures within the gastrointestinal tract.

[00110] Turning now to an aspect of therapeutic ablation methods provided herein, that of determining an appropriate site for ablational treatment (**Figure 3**), as well as the amount of ablational energy to be applied during such treatment, such determinations follow from the total amount of clinical information that a clinician can gather on a particular patient. In some aspects, the same clinical information that was relevant to the clinical status of a patient prior to bariatric bypass surgery remains equally relevant when evaluating the appropriateness of corrective ablational therapy. Appropriate information to be evaluated may include, for example, the age of the patient, the basal metabolic index, laboratory data on levels of metabolic hormones such as, merely by way of example, any of insulin, glucagon, glucagon-like peptides, insulin-like growth factors, and ghrelin, as well as data on blood glucose levels and glucose tolerance tests.

[00111] In some embodiments, a preliminary endoscopic examination of the features of a bypass-reconstructed alimentary canal may be appropriate so that any patient-specific features may be mapped out, as well as an evaluation of the general dimensions of the patient's alimentary canal, particularly the newly formed bypass structures. Such information may be obtained by direct visual observation by endoscopic approaches with optional use of mucosal *in-situ* staining agents, and may

further be accomplished by other diagnostic methods, including non-invasive penetrative imaging approaches such as narrow band imaging from an endoscope. In one aspect, evaluation of a site includes identifying the locale of the site, including its dimensions. In another aspect, evaluation of target tissue includes identifying a multiplicity of sites, if there is more than one site, and further identifying their locale and their respective dimensions. In still another aspect, evaluating target sites may include identifying or grading any pathology or injury or specific site of failure within the bypass-reconstructed gastrointestinal tract, particularly identifying any areas of clinical significance or concern that are overlapping or near the areas to be targeted for ablation. Typically, features of a gastrointestinal tract that has been subjected to bariatric surgery, and which has subsequently been found to be functionally unsuccessful in terms of the patient achieving loss of excess weight, will be dilated or distended, and show signs of being overly compliant, *i.e.*, too easily stretched.

[00112] Once target sites for ablation have been identified, bypass-reconstructed gastrointestinal target tissue may be treated with embodiments of an inventive ablational device and associated methods as described herein. Evaluation of the status of target tissue sites for ablation, particularly by visualization approaches, may also be advantageously implemented as part of an ablational therapy method (**Figure 3**), as for example, in close concert with the ablation, either immediately before the application of ablational energy (such as radiant energy), and/or immediately thereafter. Further, the treatment site can be evaluated by any diagnostic or visual method at some clinically appropriate time after the ablation treatment, as for example a few days, several weeks, or several few months, or at anytime when clinically indicated following ablational therapy. In the event that any follow-up evaluation shows either that the therapy was unsatisfactorily complete, or that there is a recovery in the population of cells targeted for ablation, a repetition of the ablational therapy may be indicated.

[00113] Turning now to aspects of ablational devices that can be directed toward ablational correction of failed bypass procedures, as described in detail herein, ablational devices have an ablational structure arrayed with energy-transmitting elements such as electrodes. In some embodiments, depending on the type of ablatative energy being used in the therapy, the devices may be mounted on, or supported by any appropriate instrument that allows movement of the ablational surface to the locale of a target site. Such instruments are adapted in form and dimension to be appropriate for reaching the target tissue site, and may include simple catheters adapted for the purpose; some embodiments of the insertive instrument include endoscopes that, in addition to their supportive role, also provide a visualization capability. In some embodiments of the method, an endoscope separate from the supportive instrument may participate in the ablational procedure by providing visual information.

[00114] Exemplary embodiments of the inventive device as described herein typically make use of electrodes to transmit radiofrequency energy, but this form of energy transmission is non-limiting, as other forms of energy, and other forms of energy-transmission hardware are included as embodiments

of the invention. Ablational energy, as provided by embodiments of the invention, may include, by way of example, microwave energy emanating from an antenna, light energy emanating from photonic elements, thermal energy transmitted conductively from heated ablatational structure surfaces or as conveyed directly to tissue by heated gas or liquid, or a heat-sink draw of energy, as provided by cryonic or cryogenic cooling of ablatational structure surfaces, or as applied by direct contact of cold gas or fluid with tissue, or by heat-draw through a wall of a device that separates the cold gas or fluid from the tissue.

[00115] Embodiments of the ablatational device include variations with regard to the circumferential expanse of the ablatational surface to be treated, some embodiments provide a fully circumferential ablation surface and others provide a surface that is less than fully circumferential, as described above. Choosing the appropriate device is a step included within the therapeutic method provided, as shown in **Figure 3**. These and other variation may provide particular advantages depending on the nature, extent, locale, and dimensions of the one or more targeted tissue sites on the wall the alimentary canal. One embodiment of the invention includes a device with an ablatational surface that is fully circumferential, *i.e.*, encompassing a radius of 360 degrees, such that a full radial zone within a luminal organ is subject to ablation. Within that zone, ablation may be implemented to a varying degree, depending on the energy output and the pattern of the ablatational elements (such as electrodes), but with substantial uniformity within the zone of ablation. This embodiment may be particularly appropriate for treating widespread or diffuse sites within a bypass-reconstructed gastrointestinal tract organ. In another embodiment of the device, the ablatational surface of the inventive device is partially circumferential, such that it engages a fraction of the full internal perimeter or circumference of a luminal organ. The fractional portion of the circumference ablated on the inner surface of a luminal organ depends on the size of the luminal organ being treated (radius, diameter, or circumference) and on the dimensions of the ablatational surface, as detailed further below. With regard to treating target sites that are small and discrete, the smaller or more discrete ablatational surface provided by this latter embodiment may be advantageous.

[00116] This type of operational control of a circumferential subset of ablation energy elements around a 360-degree circumferential array is analogous to the fractional operation of a patterned subset of an electrode array, as described below in the section titled " Electrode patterns and control of ablation patterns across the surface area of tissue". In the partially-circumferential operation of an array, a particular arc of the array is activated to deliver energy to an arc of the circumference. In the fractional-pattern operation of an array, energy is delivery to a portion of the tissue in the target area, while another portion receives insufficient energy to achieve ablation. In some embodiments, these operational variations can be combined, that is, a patterned subset of a circumferential arc can be activated.

[00117] **Figures 3 and 4** together provide flow diagram depictions of embodiments of the method for ablating tissue in the wall of the alimentary canal that has been reconstructed by a bariatric procedure, and has subsequently failed or been demonstrably ineffective. The diagrams represent common aspects of the embodiments of the method, as delivered by two embodiments of the device, one which has a 360 degree circumferential ablation structure, and one which has an ablation structure comprising an arc of less than 360 degrees.

[00118] **Figure 3** is a flow diagram depicting an overview of the method with a focus on patient evaluation and determination of a clinically appropriate site within the alimentary canal for ablational treatment. In another step, a responsible clinician makes an informed choice with regard to the appropriate embodiment with which to treat the patient, *i.e.*, either a device with the 360 degree electrode array **100A**, or a device **100B** with the electrodes arrayed in an arc of less than 360 degrees. In the event that the device **100A** is chosen for use, another treatment choice may be made between operating the electrodes throughout the 360 degree circumference, or whether to operate a radial subset of the electrode array. In another step, a clinician further considers and makes a determination as to the protocol for ablation, considering the amount of energy to be delivered, the energy density, the duration of time over which energy is to be delivered. These considerations take into the account the surface area to be ablated, the depth of tissue which is to be treated, and the features of the electrode array, whether, for example, it is to be a fractional electrode, and which pattern may be desirable. Regardless of the device chosen, another preliminary step to operating the method may include a closer evaluation of the target tissue site(s) within the alimentary canal. Evaluation of the site may include the performance of any visualization or diagnostic method that provides a detailed census of the number of discrete target tissue sites, their dimensions, their precise locations, and/or their clinical status, whether apparently normal or abnormal. This step is shown following the choice of instrument, but may occur simply in conjunction with diagnosis, or at any point after diagnosis and general localization of the target tissue. In any case, an evaluating step is typically performed prior to ablation, as outlined in the operational steps of the method, as shown in the flow diagram of **Figure 4**.

[00119] **Figure 4** is a flow diagram depicting the method after the target site within the bypass-reconstructed gastrointestinal tract has been localized and a choice has been made regarding the preferred ablational device. The method includes an evaluation of the site, including particulars of location, stage, determination of the number of sites, and the dimensions, as described above, and using approaches detailed in the references provided in the background, and/or by using whatever further approaches may be known by those practiced in the art. The method continues with insertion of the instrument and the movement of the ablational structure to the locale of the target tissue to be ablated. Subsequently, more refined movements of the ablational structure may be performed that create a therapeutically effective contact between the ablational structure and the target tissue site. In the event that the 360 degree embodiment of the device **100A** is chosen, therapeutically effective

contact may be made by inflating a balloon underlying the electrode array. In the event that the embodiment chosen is **100B**, the device with an electrode surface spanning an arc of less than 360 degrees, movements that bring the ablational surface into therapeutically effective contact may include any of inflation of a balloon, inflation of a deflection member, and/or movement of a deflection member, all of which are described further below.

[00120] After therapeutically-effective contact is made, by either device embodiment **100A** or **100B**, and by whatever type of movement was that was taken, a subsequent step includes the emission of ablational energy from the device. Variations of ablational energy emission may include ablating a single site as well as moving the instrument to a second or to subsequent sites that were identified during the evaluation step. Following the ablational event, a subsequent step may include an evaluation of the treated target site; alternatively evaluation of the consequences of ablation may include the gathering of clinical data and observation of the patient. In the event that an endoscope is included in the procedure, either as the instrument supporting the ablational structure, or as a separate instrument, such evaluation may occur immediately or very soon after ablation, during the procedure, when instruments are already in place. In other embodiments of the method, the treated site may be evaluated at any clinically appropriate time after the procedure, as for example the following day, or the following week, or many months thereafter. In the event that any of these evaluations show an ablation that was only partially complete, or show an undesired repopulation of targeted cells, the method appropriately includes a repetition of the steps just described and schematically depicted in **Figure 4**.

[00121] In addition to observation by direct visual approaches, or other diagnostic approaches of site of ablation *per se*, evaluation of the consequences of ablation may include the gathering of a complete spectrum of clinical and metabolic data from the patient. Such information includes any test that delivers information relevant to the metabolic status of the patient such as the information gathered when determining the appropriateness of ablational intervention, as was made in the first step of **Figure 3**. Similarly, evaluation of the effectiveness of the bariatric effectiveness of the ablation method may include any of a panoply of metabolic tests such as described in detail in US Patent Application Ser. No. 12/114,628 of Kelly *et al.* entitled "Method and apparatus for gastrointestinal tract ablation for treatment of obesity", as filed on filed May 2, 2008.

Device and Method for 360 Degree Circumferential Ablation

[00122] Methods for accomplishing ablation of targeted cells within the bypass-reconstructed gastrointestinal tract according to this invention include the emission of radiant energy at conventional levels to accomplish ablation of epithelial and with or without deeper levels of tissue injury, more particularly to remove or functionally compromise cells that are involved in the sensation of satiety or the regulation of metabolic hormones such as insulin. In one embodiment, as shown in **Figures 1A, 1C, and 2A**, an elongated flexible shaft **41** is provided for insertion into the body in any of various

ways selected by a medical care provider. The shaft may be placed endoscopically, *e.g.* passing through the mouth and esophagus and then further into the bypass-reconstructed gastrointestinal tract, or it may be placed surgically, or by any other suitable approach. In this embodiment, radiant energy distribution elements or electrodes on an ablation structure **101** are provided at a distal end of the flexible shaft **41** to provide appropriate energy for ablation as desired. In typical embodiments described in this section, the radiant energy distribution elements are configured circumferentially around 360 degrees. Alternatively to using emission of RF energy from the ablation structure, alternative energy sources can be used with the ablation structure to achieve tissue ablation and may not require electrodes. Such energy sources include: ultraviolet light, microwave energy, ultrasound energy, thermal energy transmitted from a heated fluid medium, thermal energy transmitted from heated element(s), heated gas such as steam heating the ablation structure or directly heating the tissue through steam-tissue contact, light energy either collimated or non-collimated, cryogenic energy transmitted by cooled fluid or gas in or about the ablation structure or directly cooling the tissue through cryogenic fluid/gas-tissue contact. Embodiments of the system and method that make use of these aforementioned forms of ablational energy include modifications such that structures, control systems, power supply systems, and all other ancillary supportive systems and methods are appropriate for the type of ablational energy being delivered.

[00123] In some embodiments of a fully circumferential ablation device, the flexible shaft comprises a cable surrounded by an electrical insulation layer and comprises a radiant energy distribution elements located at its distal end. In one form of the invention, a positioning and distending device around the distal end of the instrument is of sufficient size to contact and expand the walls of the bypass-reconstructed gastrointestinal tract lumen or organ in which it is placed (*e.g.* the gastric pouch, the stoma, or the gastric sleeve) both in the front of the energy distribution elements as well as on the sides of the energy distribution elements. For example, the distal head of the instrument can be supported at a controlled distance from the wall of the bypass-reconstructed gastrointestinal tract lumen or organ by an expandable balloon or inflation member, such that a therapeutically-effective contact is made between the ablation structure and the target site so as to allow regulation and control the amount of energy transferred to the target tissue within the lumen when energy is applied through the electrodes. The balloon is preferably bonded to a portion of the flexible shaft at a point spaced from the distal head elements.

[00124] Some embodiments of a fully-circumferential ablation device include a distensible or expandable balloon member as the vehicle to deliver the ablation energy. One feature of this embodiment includes means by which the energy is transferred from the distal head portion of the invention to the membrane comprising the balloon member. For example, one type of energy distribution that may be appropriate and is incorporated herein in its entirety is shown in U.S. Pat. No. 5,713,942, in which an expandable balloon is connected to a power source that provides radio

frequency power having the desired characteristics to selectively heat the target tissue to a desired temperature. A balloon per embodiments of the current invention may be constructed of an electroconductive elastomer such as a mixture of polymer, elastomer, and electroconductive particles, or it may comprise a nonextensible bladder having a shape and a size in its fully expanded form which will extend in an appropriate way to the tissue to be contacted. In another embodiment, an electroconductive member may be formed from an electroconductive elastomer wherein an electroconductive material such as copper is deposited onto a surface and an electrode pattern is etched into the material and then the electroconductive member is attached to the outer surface of the balloon member. In one embodiment, the electroconductive member, *e.g.* the balloon member **105**, has a configuration expandable in the shape to conform to the dimensions of the expanded (not collapsed) inner lumen of the human lower bypass-reconstructed gastrointestinal tract. In addition, such electroconductive member may consist of a plurality of electrode segments arrayed on an ablation structure **101** having one or more thermistor elements associated with each electrode segment by which the temperature from each of a plurality of segments is monitored and controlled by feedback arrangement. In another embodiment, it is possible that the electroconductive member may have means for permitting transmission of microwave energy to the ablation site. In yet another embodiment, the distending or expandable balloon member may have means for carrying or transmitting a heatable fluid within one or more portions of the member so that the thermal energy of the heatable fluid may be used as the ablation energy source.

[00125] Some embodiments of a fully circumferential ablation device include a steerable and directional control means, a means for accurately sensing depth of cautery, and appropriate alternate embodiments so that in the event of a desire not to place the electroconductive elements within the membrane forming the expandable balloon member it is still possible to utilize the balloon member for placement and location control while maintaining the energy discharge means at a location within the volume of the expanded balloon member, such as at a distal energy distribution head.

[00126] Embodiments of the invention include methods whereby an ablation device, such as a fully circumferential ablation device, is used as a method of restoring or rescuing the therapeutic effectiveness of bariatric procedures that have failed or are degrading due to a compromise or unsatisfactory result in a surgically formed gastrointestinal tract feature. In one aspect, the surgery can be understood as an initial therapy that has failed, and the ablation can be understood as a secondary interventional therapy. As such, the primary indication remains, *i.e.*, the metabolic disease, but the ablational therapy is being directed more immediately toward supporting the initial surgical intervention. Ablational targets, thus include structures such as a gastric pouch, stomas formed by the procedure, or gastric tubes or sleeves. After determining that the portion or portions of the bypass-reconstructed gastrointestinal tract wall having this tissue that is targeted either for full or partial ablation, the patient is prepared for a procedure in a manner appropriate according to the embodiment

of the device to be utilized. Then, the practitioner inserts into the patient, in one embodiment, the ablation device shown and discussed herein via endoscopic access and control. Further positioning of portions of the device occurs as proper location and visualization identifies the ablation site in the bypass-reconstructed gastrointestinal tract. Selection and activation of the appropriate quadrant(s) or portion(s)/segment(s) on the ablation catheter member is performed by the physician, including appropriate power settings according to the depth of cautery desired. Additional settings may be necessary as further ablation is required at different locations and/or at different depths within the patient's bypass-reconstructed gastrointestinal tract. Following the ablation, appropriate follow-up procedures as are known in the field are accomplished with the patient during and after removal of the device from the bypass-reconstructed gastrointestinal tract.

[00127] In yet another method of the invention, the practitioner may first determine the length of the portion of the bypass-reconstructed gastrointestinal tract requiring ablation and then may choose an ablation catheter from a plurality of ablation catheters of the invention, each catheter having a different length of the electrode member associated with the balloon member. For example, if the practitioner determines that 1 centimeter of the bypass-reconstructed gastrointestinal tract surface required ablation, an ablation catheter having 1 centimeter of the electrode member can be chosen for use in the ablation. The length of the electrode member associated with the balloon member can vary in length, as for example, from 1 to 10 cm.

[00128] In yet another embodiment, a plurality of ablation catheters wherein the radiant energy distribution elements are associated with the balloon member can be provided wherein the diameter of the balloon member when expanded varies from 12 mm to 40 mm. In this method, the practitioner will choose an ablation catheter having a diameter when expanded which will cause the bypass-reconstructed gastrointestinal tract to stretch and the mucosal layer to thin out, thus, reducing or occluding blood flow at the site of the ablation. It is believed that by reducing the blood flow in the area of ablation, the heat generated by the radiant energy is less easily dispersed to other areas of the target tissue thus focusing the energy to the ablation site.

[00129] One approach a practitioner may use to determine the appropriate diameter ablation catheter to use with a particular patient is to use in a first step a highly compliant balloon connected to a pressure sensing mechanism. The balloon may be inserted into a luminal organ within the bypass-reconstructed gastrointestinal tract and positioned at the desired site of the ablation and inflated until an appropriate pressure reading is obtained. The diameter of the inflated balloon may be determined and an ablation device of the invention having a balloon member capable of expanding to that diameter chosen for use in the treatment. In the method of this invention, it is desirable to expand the expandable electroconductive member such as a balloon sufficiently to occlude the vasculature of the submucosa, including the arterial, capillary or venular vessels. The pressure to be exerted to do so should therefore be greater than the pressure exerted by such vessels.

[00130] In other embodiments of the method, electronic means are used for measuring the luminal target area of gastrointestinal features that have been formed by bariatric surgery so that energy may be appropriately normalized for the surface area of the target tissue. These aspects of the method are described in detail in US Patent Application Ser. No. 12/143,404, of Wallace *et al.*, entitled "Electrical means to normalize ablational energy transmission to a luminal tissue surface of varying size", as filed on June 20, 2008, which is incorporated in entirety. An embodiment of a device with a 360 degree ablational surface is described in detail in that application, and is depicted in **Figures 57A – 57D** of this application. Pressure sensing means may also be used to measure the size of a lumen in preparation for an ablation treatment, as described in U.S. Patent Application No. 11/244,385 of Jackson, published as US 2006/0095032.

[00131] An embodiment of a device disclosed in US Patent Application Ser. No. 12/143,404, of Wallace *et al* will be described here briefly, in order to provide an embodiment that includes a 360-degree ablational surface arranged on an overlapping support that expands in accordance with a balloon enclosed within the circumference of the support. Although the circumference of the device as a whole expands with the balloon, the ablational surface itself is non-distensible, and maintains its electrode density. **Figures 57A – 57D** provide perspective views of an ablation device **100** with an overlapping electrode support **360** furled around an expandable balloon **105**. An array of ablational energy delivery elements **101** such as radiofrequency electrodes is arranged on the exterior surface of the electrode support. The operative element is mounted on the distal end of an ablation catheter, of which the distal portion of a shaft **41** is seen, and around which the balloon **105** is configured. **Figure 57A** shows the electrode support **360** pulled away from the balloon **105** to clarify that a portion of the support and an inner edge **362** is adherent to the balloon, and another portion and its outer edge **364** is not connected to the balloon. **Figure 57B** shows the non-adherent portion of the electrode support **360** furled around the balloon **105** in a deployable configuration, the non-adherent portion and its edge overlapping around the adherent portion. **Figure 57C** shows an optional feature of the device **100A**, one or more elastic bands **380** wrapped around the electrode support **360**. In some embodiments, the elastic band **380** material is a conductive elastomer, as described in greater detail below, which can be included in a size-sensing circuit to provide information related to the degree of expansion of the operative element. **Figure 57D** shows the device of **Figure 57C** in a collapsed state, with balloon portion **105** being uninflated (or deflated), this being the state of the device when it is being deployed into a lumen and being positioned at a target site, as well as the state of the device after delivering ablation energy and about to be removed from the lumen.

[00132] Another embodiment of an ablation device with a fully circumferential ablation surface is provided in **Figures 58A – 58B**. This particular device embodiment **400** is adapted to present an ablational surface **101** into a concave or inwardly tapered target site such as distal portion of the antrum of the stomach, or in the vicinity of the pylorus, which is a site for vascular lesions typical of

watermelon stomach. The device includes an ablational surface circumferentially arranged on the distal portion of an expandable member **105**, the expandable member mounted around the distal end **110** of the shaft of an endoscope **111**. **Figure 58A** shows the device in a deployed configuration. **Figure 58B** shows the device with the expandable member in an unexpanded or collapsed state, as would be appropriate for deployment of the device to a target tapered surface, or as would be appropriate for removal from the ablational site. **Figure 58C** shows the device of **Figure 58A** as it can be deployed into a tapered or concave target site such as the pylorus **9**. **Figure 58D** shows the device of **Figure 58A** in an alternative configuration, with the electrode bearing surface of the device reversed such that it is facing proximally, and can thus be pulled retrograde into a tapered or concave site such as the lower esophageal sphincter **10**.

Electrode patterns and control of ablation patterns across the surface area of tissue

[00133] Some aspects of embodiments of the ablational device and methods of use will now be described with particular attention to the electrode patterns present on the ablation structure. The device used is shown schematically in **Figures 5 – 7**. As shown in **Figure 6**, the elongated flexible shaft **41** of a device with a fully circumferential ablation surface is connected to a multi-pin electrical connector **94** which is connected to the power source and includes a male luer connector **96** for attachment to a fluid source useful in expanding the expandable member. The elongated flexible shaft has an electrode **98** wrapped around the circumference. The expandable member of the device shown in **Figures 5 and 6** further includes three different electrode patterns, the patterns of which are represented in greater detail in **Figures 7A – 7C**. Typically, only one electrode pattern is used in a device of this invention, although more than one may be included. In the device shown in **Figure 5**, the elongated flexible shaft **41** comprises six bipolar rings **62** with about 2 mm separation at one end of the shaft (one electrode pattern), adjacent to the bipolar rings is a section of six monopolar bands or rectangles **65** with about 1 mm separation (a second electrode pattern), and another pattern of bipolar axial interlaced finger electrodes **68** is positioned at the other end of the shaft (a third electrode pattern). In this device, a null space **70** is positioned between the last of the monopolar bands and the bipolar axial electrodes. The catheter used in the study was prepared using a polyimide flat sheet of about 1 mil (0.001") thickness coated with copper. The desired electrode patterns were then etched into the copper.

[00134] Alternative electrode patterns are shown in **Figures 8A – 8D** as **80, 84, 88, and 92**, respectively. Pattern **80** is a pattern of bipolar axial interlaced finger electrodes with about 0.3 mm separation. Pattern **84** includes monopolar bands with 0.3 mm separation. Pattern **88** is that of electrodes in a pattern of undulating electrodes with about 0.25 mm separation. Pattern **92** includes bipolar rings with about 0.3 mm separation. In this case the electrodes are attached to the outside surface of a balloon **72** having a diameter of about 18 mm. The device may be adapted to use radio

frequency by attaching wires 74 as shown in **Figure 5** to the electrodes to connect them to the power source.

[00135] The preceding electrode array configurations are described in the context of an ablation structure with a full 360 degree ablation surface, but such patterns or variants thereof may also be adapted for ablation structures that provide energy delivery across a surface that is less than completely circumferential, in structures, for example, that ablate over any portion of a circumference that is less than 360 degrees, or for example structures that ablate around a radius of about 90 degrees, or about 180 degrees.

[00136] Embodiments of the ablation system provided herein are generally characterized as having an electrode pattern that is substantially flat on the surface of an ablation support structure and which is non-penetrating of the tissue that it ablates. The electrode pattern forms a contiguous treatment area that comprises some substantial radial aspect of a luminal organ; this area is distinguished from ablational patterns left by electrical filaments, filament sprays, or single wires. In some embodiments of the invention the radial portion may be fully circumferential; the radial portion of a luminal organ that is ablated by embodiments of the invention is function of the combination of (1) the circumference of the organ, which can be relatively large in the case of gastric pouch, and small when in the case of a region in a stoma or a gastric sleeve, and (2) the dimensions of the electrode pattern. Thus, at the high end, as noted, the radial expanse of a treatment area may be as large as 360 degrees, and as small as about 5 to 10 degrees, as could be the case in a treatment area within the stomach.

[00137] Embodiments of the ablational energy delivery system and method provided are also characterized by being non-penetrating of the target tissue. Ablational radiofrequency energy is delivered from the flat electrode pattern as it makes therapeutic contact with the tissue surface of a treatment area, as described elsewhere in this application; and from this point of surface contact, energy is directly inwardly to underlying tissue layers.

[00138] Some embodiments of the ablational system and method provided herein can be further characterized by the electrode pattern being configured to achieve a partial or fractional ablations, such that only a portion of the tissue surface receives sufficient radiofrequency energy to achieve ablation and another portion of the surfaces receives insufficient energy to achieve ablation. The system and method can be further configured to control the delivery of radiofrequency energy inwardly from the tissue surface such that depth of tissue layers to which energy sufficient for ablation is delivered is controlled.

[00139] Controlling the fraction of the tissue surface target area that is ablated comes about by having some fraction of the tissue ablated, at least to some degree, and having some fraction of the surface within the target area emerge from the treatment substantially free of ablation. The ability to control the ratio of ablated and non-ablated surface can provide substantial benefit to the treatment. The ablational target areas in this method, after all, are not cancerous, in which case their complete

ablation may be desired, and in fact the target areas may not be abnormal in any sense. The ablational treatment, per embodiments of this invention, may be directed not necessarily toward correcting any defect of the target tissue, but rather toward a larger therapeutic end, where, in fact, that end is served by creation of a modulated dampening of the normal properties or function of the target area. It may not be the case, for example, when treating a compromised feature of a gastrointestinal tract reconfigured by a bariatric surgery, or an underlying metabolic condition such as obesity or diabetes, that it is desirable to render a complete ablation, it may be that what is desired is a modulated approach, where a varying degree of dysfunction can be provided, without substantially damaging the organ, or a particular layer of the organ. Stated in another way, it may be generally desirable for the health of the organ within which the target area is located, and for the health of the individual as a whole, that some degree of normal functioning remain after ablation.

[00140] By way of an illustrative example as to what is desirable and being provided by the invention, the organ in which the ablation target area is located can be appreciated as a population of particular target cells within the tissue of the target area, which can function, based on their health, at a functional capacity at some low threshold of 20%, for example, when in poor condition, and at 100%, when in optimal condition. The object of the ablational treatment provided herein, within this example by analogy may not be to render the full population of cells to be dysfunctional and operating at 50% capacity. The object of the treatment may be to have some fraction of the cells within the population, post-ablational treatment, to remain fully functional, operating at about 100% capacity, and to have some remaining fraction operating at a range of lower capacity.

[00141] Controlling the fraction of the tissue surface target area that is ablated, per embodiments of the invention, is provided by various exemplary approaches: for example, by (1) the physical configuration of electrode pattern spacing in a comparatively non-dense electrode pattern, and by (2) the fractional operation of a comparatively dense electrode array, in a billboard-like manner. Generally, creating a fractional ablation by physical configuration of the electrode pattern includes configuring the electrode pattern such that some of the spacing between electrodes is sufficiently close that the conveyance of a given level of energy between the electrodes sufficient to ablate tissue is allowed, and other spacing between electrodes is not sufficiently close enough to allow conveyance of the level of energy sufficient to ablate. Embodiments of exemplary electrode patterns that illustrate this approach to creating fractional ablation are described below, and depicted in **Figures 48 – 55**. The creation of an ablation pattern by activating a subset of electrodes represents an operation of the inventive system and method which is similar to the described above, wherein an ablational structure with a fully circumferential pattern of electrodes can be operated in a manner such that only a radial fraction of the electrodes are operated.

[00142] The ablation system of the invention includes an electrode pattern with a plurality of electrodes and a longitudinal support member supporting the electrode pattern, as described in

numerous embodiments herein. Energy is delivered to the electrodes from a generator, and the operation of the generator is controlled by a computer-controller in communication with the generator, the computer controller controlling the operating parameters of the electrodes. The computer controller has the capability of directing the generator to deliver energy to all the electrodes or to a subset of the electrodes. The controller further has the ability to control the timing of energy delivery such that electrodes may be activated simultaneously, or in subsets, non-simultaneously. Further, as described elsewhere, the electrodes may be operated in a monopolar mode, in a bipolar mode, or in a multiplexing mode. These various operating approaches, particularly by way of activating subsets of electrodes within patterns, allow the formation of patterns that, when the pattern is in therapeutic contact with a target surface, can ablate a portion of tissue in the target area, and leave a portion of the tissue in the target area non-ablated.

[00143] Generally, creating a fractional ablation by an operational approach with a comparatively dense electrode array includes operating the electrode pattern such that the energy delivered between some of the electrodes is sufficient to ablate, whereas energy sufficient to ablate is not delivered between some of the electrodes. Embodiments of exemplary electrode patterns that illustrate this approach to creating fractional ablation are described below, and depicted in **Figures 48 – 55**.

[00144] Another aspect of controlling the fraction of tissue ablation, per embodiments of the invention, relates to controlling the depth of ablation into tissue layers within the target area. Energy is delivered inwardly from the surface, thus with modulated increases in energy delivery, the level of ablation can be controlled such that, for example, the ablated tissue may consist only of tissue in the epithelial layer, or it may consist of tissue in the epithelial layer and the lamina propria layers, or it may consist of tissue in the epithelial, lamina propria and muscularis mucosal layers, or it may consist of tissue in the epithelial, lamina propria, muscularis mucosa, and submucosal layers, or it may consist of tissue in the epithelial layer, the lamina propria, the muscularis mucosae, the submucosa, and the muscularis propria layers. Typically, ablational energy not delivered to the serosal layer of the bypass-reconstructed gastrointestinal tract.

[00145] Embodiments of the invention include RF electrode array patterns that ablate a fraction of tissue within a given single ablational area, exemplary fractional arrays are shown in **Figures 48A, 49A, and 50A**. These fractional ablation electrode arrays may be applied, as above, to above to ablational structures that address a fully circumferential target area, or a structure that addresses any portion of a full circumference such as 90 degree radial surface, or a 180 degree radial surface. **Figure 48A** shows a pattern **180** of linear electrodes **60** aligned in parallel as stripes on a support surface. The electrodes are spaced apart sufficiently such that when pressed against tissue in therapeutic contact, the burn left by distribution of energy through the electrodes results in a striped pattern **190** on the target tissue as seen in **Figure 48B** corresponding to the electrode pattern, with there being stripes of burned or ablated tissue **3a** that alternate with stripes of unburned, or substantially unaffected tissue

3b. In some embodiments of the method, particularly in ablation structures that address a target area of less than 360 radial degrees, such as a target surface that is about 180 degrees, or more particularly about 90 degrees of the inner circumference of a lumen, the ablation may be repeated with the ablational structure positioned at a different angle. **Figure 48C**, for example, depicts a tissue burn pattern **191** created by a first ablational event followed by a second ablational event after the ablational structure is laterally rotated by about 90 degrees. **Figure 48D**, for another example, depicts a tissue burn pattern **192** created by a first ablational event followed by a second ablational event after the ablational structure is laterally rotated by about 45 degrees.

[00146] The effect of an ability to ablate a tissue surface in this manner adds another level of fine control over tissue ablation, beyond such parameters as total energy distributed, and depth of tissue ablation. The level of control provided by fractional ablation, and especially when coupled with repeat ablational events as described above in **Figures 48C and 48D**, is to modulate the surface area-distributed fraction of tissue that is ablated to whatever degree the local maximal ablation level may be. The fractional ablation provided by such fractional electrode pattern may be particularly advantageous when the effects of ablation are not intended to be absolute or complete, but instead a functional compromise of tissue, or of cells within the tissue is desired. In some therapeutic examples, thus, a desirable result could be a partial reduction in overall function of a target area, rather than a total loss of overall function. Another example where such fractional ablation may be desirable is in the case where ablation is intended to be temporary or transient. In a fractional ablation of a target area in the wall of a bypass-reconstructed gastrointestinal lumen, for example, a desirable result may be the transient compromise of tissue during which time the effect of such compromise may be evaluated. In an ablation pattern that includes a burned area **3a** and an unburned area **3b**, it can be understood that cells from the unburned area could give rise to cells that would migrate or repopulate the denuded area within the burned area **3b**.

[00147] **Figures 49A and 50A** depict other examples of a fractionally-ablating electrode pattern on an ablation structure, and **Figures 49B and 50B** show the respective fractional burn patterns on tissue that have been treated with these electrode patterns. In **Figure 49A** a pattern of concentric circles **182** is formed by wire electrodes that (from the center and moving outward) form a + - - + + - pattern. When activated, the tissue between + - electrodes is burned, and the tissue between ++ electrode pairs or - - electrode pairs is not burned. Thus, the concentric pattern **192** of **Figure 49B** is formed. Embodiments of fractionally-ablating electrode patterns such as those in **Figure 49A** need not include perfect circles, and the circles (imperfect circles or ovals) need not be perfectly concentric around a common center.

[00148] Similarly, **Figure 50A** shows a checkerboard pattern **184** of + and - electrodes which when activated create a burn pattern **194** as seen in **Figure 50B**. Tissue that lies between adjacent + and - electrodes is burned, while tissue that lies between adjacent + + electrodes or - - electrode pairs

remains unburned. **Figure 50B** includes a representation of the location of the + and – electrodes from the ablation structure in order to clarify the relative positions of areas that are burned **3a** and the areas that remain substantially unburned **3b**.

[00149] Embodiments of the invention include RF electrode array patterns that ablate a fraction of tissue within a given single ablational area by virtue of operational approaches, whereby some electrodes of a pattern are activated, and some are not, during an ablational event visited upon a target area. Exemplary fractional arrays are shown in **Figures 51A, 52A, 53A and 54A**. These fractional ablation electrode arrays may be applied, as above, to ablational structures that address a fully circumferential target area, or a structure that addresses any portion of a full circumference such as, by way of example, a 90 degree radial surface, or a 180 degree radial surface.

[00150] **Figure 51A** shows a checkerboard electrode pattern during an ablational event during which all electrode squares of the operational pattern **186A** are operating, as depicted by the sparkle lines surrounding each electrode. Operating the electrode pattern **186A** in this manner produces an ablation pattern **196A**, as seen in **Figure 51B**, wherein the entire surface of tissue within the treatment area is ablated tissue **3a**. **Figure 52A**, on the other hand, shows a checkerboard electrode pattern during an ablational event during which only every-other electrode square of the operational pattern **186B** is operating, as depicted by the sparkle lines surrounding each activated electrode. Operating the electrode pattern **186B** in this manner produces an ablation pattern **196B**, as seen in **Figure 52B**, wherein a checkerboard fractionally ablated pattern with a dispersed pattern of ablated squares **3a** of tissue **3a** alternate with square areas of tissue **3b** that are not ablated.

[00151] **Figure 53A** shows a striped linear electrode pattern of alternating + and – electrodes during an ablational event during which all electrode squares of the operational pattern **188A** are operating, as depicted by the sparkle lines surrounding each linear electrode. Operating the electrode pattern in this manner **188A** produces an ablation pattern **198A**, as seen in **Figure 53B**, wherein the entire surface of tissue within the treatment area is ablated tissue **3a**.

[00152] **Figure 54A**, on the other hand, shows a striped linear electrode pattern **188B** of alternating + and – electrodes during an ablational event during which alternate pairs of the linear electrode pairs are operating, as depicted by the sparkle lines surrounding the activated linear electrodes. Operating the electrode pattern in this manner **188B** produces an ablation pattern **198B**, as seen in **Figure 54B**, wherein stripes of ablated tissue **3a** within the treatment area alternate stripes of non-ablated tissue **3b**.

[00153] **Figure 55** is a schematic rendering of a three dimensional view of a target region of a radial portion of a bypass-reconstructed gastrointestinal wall after it has been ablationally treated, per embodiments of the invention. Ablated regions **3a** are rendered as regions distributed through the target area within a larger sea of non-ablated tissue **3b**. These regions are depicted as being slightly conical in this schematic view, but in practice the ablated tissue region may be more cylindrical in shape. The regions **3a** are of approximately the same depth, because of the control exerted over the

depth of the ablation area into layers of the gastrointestinal wall, as described herein. With such control, the regions **3a** can vary with respect of the layer to which they extend continuously from the upper surface where ablational energy has been applied. The conical regions are of approximately the same width or diameter, and distributed evenly throughout the tissue, because of the control over ablational surface area, as described herein. In this particular example, the therapeutic target is actually a particular type of cell **4b** (open irregular spheres), for example, a nerve cell, or endocrine secretory cell; and these cells are distributed throughout the target area. The post-ablation therapeutic target cells **4a** (dark irregular spheres) are those which happened to be included within the conical regions **3a** that were ablated. The post-ablation cells **4a** may be rendered dysfunctional to varying degree, they may be completely dysfunctional, they may be, merely by way of illustrative example, on the average, 50% functional by some measure, and their functionality may vary over a particular range. It should be particularly appreciated however, per embodiments of the invention, that the cells **4b**, those not included in the ablated tissue cones, are fully functional.

Controlling the ablation in terms of the tissue depth of the ablation effect

[00154] In addition to controlling the surface area distribution of ablation, as may be accomplished by the use of fractional ablation electrodes as described above, or as controlled by the surface area of electrode dimensions, ablation can be controlled with regard to the depth of the ablation below the level of the tissue surface where the ablative structure makes therapeutic contact with the tissue. The energy delivery parameters appropriate for delivering ablation that is controlled with regard to depth in tissue may be determined experimentally. By way of example, an experimental set of exercises was performed on normal immature swine in order to understand the relationship between the electrical parameters of electrode activation and the resultant level of ablation in esophageal tissue. The data are shown in detail in US Application No. 10/370,645 of Ganz *et al*, filed on February 19, 2003, and in the publication on August 21, 2003, of that application, US 2003/0158550 A1, particularly in Tables 1 – 4 of that application. By an approach such as this, appropriate parameters for ablation of other tissues in the bypass-reconstructed gastrointestinal tract may be determined. Such parameters as applied by ablational electrode patterns on an ablational structure with a 360 degree operating surface that is directed to esophageal tissue, by way of example, include 300W delivered within 300 msec, with a tightly spaced with tightly spaced bi-polar electrode array (less than 250 microns). Ablation depth related to the energy density delivered with 8-12J/cm² results in complete removal of the epithelium. Such parameters as applied by electrode patterns on an ablation structure with an operating radial surface of about 90 degrees includes multiple narrow band electrodes spaced 250 microns wide, where the generator delivers very high power energy density at 40W/cm² to the tissue in an energy dosage of 12-15 J/cm². In general, depth variances can be achieved via time of ablation, dosage, number of energy applications, and electrode spacing.

[00155] **Figure 25** provides a schematic representation of the histology of the bypass-reconstructed gastrointestinal wall as it is found in various luminal organs such as the esophagus, stomach, pylorus, duodenum, and jejunum. The relative presence and depth and composition of the layers depicted in **Figure 25** vary from organ to organ, but the basic organization is similar. The layers of the bypass-reconstructed gastrointestinal wall will be described in their order from the innermost to the outermost layer facing the bypass-reconstructed gastrointestinal lumen; and as seen **Figure 25** and in terms of the direction from which an ablational structure would approach the tissue. The innermost layer can be referred to as the surface (epithelium), and succeeding layers can be understood as being below or beneath the "upper" layers. The innermost layer of a bypass-reconstructed gastrointestinal tract organ, which is in direct contact with the nutrients and processed nutrients as they move through the gut is a layer of epithelium **12**. This layer secretes mucous which protects the lumen from abrasion and against the corrosive effect of an acidic environment. Beneath the epithelium is a layer known as the lamina propria **13**, and beneath that, a layer known as the muscularis mucosae **14**. The epithelium **12**, the lamina propria **13**, and the muscularis mucosae **14** collectively constitute the mucosa **15**.

[00156] Below the mucosal layer **15** is a layer known as the submucosa **16**, which forms a discrete boundary between the mucosal layer **15** above, and the muscularis propria **17** below. The muscularis propria **17** includes various distinct layers of smooth muscle that enwrap the organ, in various orientations, including oblique, circular, and the longitudinal layers. Enwrapping the muscularis propria **17** is the serosa **18**, which marks the outer boundary of the organ.

[00157] The entirety of the bypass-reconstructed gastrointestinal tract wall is highly vascular and innervated. The mucosal layer is particular rich in glands and cells that secrete contents into the lumen and secrete hormones into the bloodstream. The nerves in this region are sensitive to the chemical composition of the nutrient flow, as it passes by, and their synaptic signals convey information to other organs that are involved in nutrient processing, such as the pancreas, and to the central nervous system, where information is integrated and regulates appetite and satiety. Nerve cells, proprioceptors, in the muscularis propria sense the physical state of the wall, whether it is contracted or extended, and motor neurons in the musculature control the tension and general motility of the organ. All of these cells, including vasculature, exocrine cells, endocrine cell, and nerve cells are potential targets for ablation when ablational energy is directed toward the region in which they reside. As a result of receiving energy, cells may be killed or scarred to an extent that they are no longer functional, or they may be partially damaged, leaving some level of function. Additionally, it should be understood that these cells all exist in populations, and a partial ablation may manifest in a statistical distribution of damage, in which some cells of the population are eliminated or damaged beyond redemption, and some cells may remain substantially unaffected, and fully functional. In such partial or fractional ablation events, it can be understood that the remnant level of function following therapeutic ablation may include a range of function and dysfunction.

[00158] As provided by embodiments of the invention, the ablation applied to bypass-reconstructed gastrointestinal wall tissue may be depth-controlled, such that only the epithelium **12**, or only a portion of the mucosal layer is ablated, leaving the deeper layers substantially unaffected. In other embodiments, the ablated tissue may commence at the epithelium yet extend deeper into the submucosa and possibly the muscularis propria, as necessary to achieve the desired therapeutic effect.

Device and Method for Partially-Circumferential Ablation

[00159] One embodiment of a method of ablating tissue in the bypass-reconstructed gastrointestinal tract includes the use of an ablation device with an ablation structure supported by conventional endoscopes **111**, as illustrated in **Figure 24**. As described herein, more particularly, the tissue targeted for ablation by embodiments of an ablation device and methods therefore is on the wall of the bypass-reconstructed gastrointestinal tract in the lumen of an organ such as the gastric pouch, stoma, or gastric sleeve. An example of one commercially available conventional endoscope **111** is the Olympus "gastrovideoscope" model number GIF-Q160. While the specific construction of particular commercially available endoscopes may vary, as shown in **Figure 24**, most endoscopes include a shaft **164** having a steerable distal end **110** and a hub or handle **162** which includes a visual channel **161** for connecting to a video screen **160** and a port **166** providing access to an inner working channel within the shaft **164**. Dials, levers, or other mechanisms (not shown) will usually be provided on the handle **162** to allow an operator to selectively steer the distal end **110** of the endoscope **111** as is well known in the endoscopic arts. In accordance with the present invention, an ablation device, including an ablation structure is advanced into the bypass-reconstructed gastrointestinal tract while supported at the distal end of an endoscope. The ablation structure is deflectable toward a tissue surface and the ablation structure is activated to ablate the tissue surface. Within the bypass-reconstructed gastrointestinal tract, variously sized tissue surface sites can selectively be ablated using the device. As will be further described, the ablational structure of embodiments described in this section do not circumscribe a full 360 degrees, but rather circumscribe a fraction of 360 degrees, as will be described further below.

[00160] In general, in one aspect a method of ablating tissue in the bypass-reconstructed gastrointestinal tract is provided. The method includes advancing an ablation structure into the bypass-reconstructed gastrointestinal tract while supporting the ablation structure with an endoscope. In some embodiments, advancing the structure into the bypass-reconstructed gastrointestinal may be sufficient to place the ablational structure of the device into close enough proximity in order to achieve therapeutic contact. In other embodiments, a subsequent step may be undertaken in order to achieve an appropriate level of therapeutic contact. This optional step will be generally be understood as moving the ablation structure toward the target site. The method thus may further include moving at least part of the ablation structure with respect to the endoscope and toward a tissue surface; and activating the ablation structure to ablate the tissue surface. Moving at least part of the ablation

structure with respect to the endoscope can include movement toward, away from or along the endoscope. Moving the ablational structure toward a target tissue surface may be performed by structures in ways particular to the structure. For example, the structure can be moved by inflating a balloon member, expanding a deflection member, or moving a deflection member. The function of such movement is to establish a therapeutically effective contact between the ablational structure and the target site. A therapeutically effective contact includes the contact being substantial and uniform such that the highly controlled electrical parameters of radiant emission from the electrode result in similarly highly controlled tissue ablation. Some embodiments of the invention further include structure and method for locking or securing such a therapeutically effective contact once established. Thus, some embodiments include a position locking step that, for example, uses suction to secure the connection between the ablation structure and the tissue site.

[00161] As shown in **Figures 9, 10, 11, and 26**, in one aspect a method of ablating tissue in the a reconstructed gastrointestinal tract feature includes an ablation device **100** for ablating a tissue surface **3**, wherein the device **100** includes an ablating structure, for example, an ablation structure **101** supported by an endoscope **111**. The method includes ablating tissue in the wall of a luminal organ of the bypass-reconstructed gastrointestinal tract by the steps of **(1)** advancing the ablation structure **101** into the luminal organ; **(2)** deflecting the ablation structure **101** toward a tissue surface **3**; and **(3)** activating the ablation structure to ablate the tissue surface **3**. As shown in **Figure 9**, the device **100** can additionally include a housing **107**, electrical connections **109**, an inflation line **113** and an inflation member or balloon **105**.

[00162] The ablation structure **101**, in one embodiment is an electrode structure configured and arranged to deliver energy comprising radiofrequency energy to the mucosal layer of the wall of the organ of the bypass-reconstructed gastrointestinal tract. It is envisioned that such an ablation structure **101** can include a plurality of electrodes. For example, two or more electrodes may be part of an ablation structure. The energy may be delivered at appropriate levels to accomplish ablation of mucosal or submucosal level tissue, or alternatively to cause therapeutic injury to these tissues, while substantially preserving muscularis tissue. The term "ablation" as used herein generally refers to thermal damage to the tissue causing any of loss of function that is characteristic of the tissue, or tissue necrosis. Thermal damage can be achieved through heating tissue or cooling tissue (*i.e.* freezing). In some embodiments ablation is designed to be a partial ablation.

[00163] Although radiofrequency energy, as provided by embodiments of the invention, is one particular form of energy for ablation, other embodiments may utilize other energy forms including, for example, microwave energy, or photonic or radiant sources such as infrared or ultraviolet light, the latter possibly in combination with improved sensitizing agents. Photonic sources can include semiconductor emitters, lasers, and other such sources. Light energy may be either collimated or non-collimated. Other embodiments of this invention may utilize heatable fluids, or, alternatively, a

cooling medium, including such non-limiting examples as liquid nitrogen, Freon™, non-CFC refrigerants, CO₂ or N₂O as an ablation energy medium. For ablations using hot or cold fluids or gases, the ablation system may include an apparatus to circulate the heating/cool medium from outside the patient to the heating/cooling balloon or other element and then back outside the patient again. Mechanisms for circulating media in cryosurgical probes are well known in the ablation arts. For example, and incorporated by reference herein, suitable circulating mechanisms are disclosed in U.S. Pat. No. 6,182,666 to Dobak; U.S. Pat. No. 6,193,644 to Dobak; U.S. Pat. No. 6,237,355 to Li; and U.S. Pat. No. 6,572,610 to Kovalcheck.

[00164] In a particular embodiment, the energy delivered to the wall of a luminal organ of the bypass-reconstructed gastrointestinal tract comprises radiofrequency energy that can be delivered from the energy delivery device **100**. Radiofrequency energy can be delivered in a number of ways. Typically, the radiofrequency energy will be delivered in a bipolar fashion from a bipolar array of electrodes positioned on the ablation structure **101**, in some cases on an expandable structure, such as a balloon, frame, cage, or the like, which can expand and deploy the electrodes directly against or immediately adjacent to the mucosal tissue so as to establish a controlled level of therapeutic contact between the electrodes and the target tissue (*e.g.*, through direct contact or through a dielectric membrane or other layer). Alternatively, the electrode structure may include a monopolar electrode structure energized by a radiofrequency power supply in combination with a return electrode typically positioned on the patient's skin, for example, on the small of the back. In any case, the radiofrequency energy is typically delivered at a high energy flux over a very short period of time in order to injure or ablate only the mucosal or submucosal levels of tissue without substantially heating or otherwise damaging the muscularis tissue. In embodiments where the ablation structure includes a plurality of electrodes, one or more of the electrodes can be bipolar or monopolar, and some embodiments include combinations of bipolar and monopolar electrodes.

[00165] The ablation structure **101** can be arranged and configured in any of a number of ways with regard to shape and size. Typically, the array has an area in the range from about 0.5 cm² to about 9.0 cm². Typical shapes would include rectangular, circular or oval. In one embodiment, the ablation structure **101** has an area of about 2.5 cm². In another embodiment, the ablation structure **101** has an area of about 4 cm² and dimensions of about 2 cm. by 2 cm.

[00166] The housing **107** of the ablation device **100** is arranged and configured to support the ablation structure **101**. The housing **107** can be made of any suitable material for withstanding the high energy flux produced by the ablation structure **101**. As shown in **Figures 9 - 14, 17, 18, 21, and 22**, in one embodiment, the housing **107** is sandwiched between the ablation structure **101** and an endoscope **111** when the ablation device **100** is supported by an endoscope **111**. One end of the ablation structure **101** can be further away from the endoscope than the other end to improve ease of contact with the targeted tissue (not shown). For example, to ensure the proximal end of the ablation

structure 101 makes contact with the targeted tissue, the proximal end of the electrode may be supported by a tapered housing member 107.

[00167] The electrical connections 109 of the ablation device connect the ablation structure 101 to a power source. The electrical connections 109 can include a single wire or plurality of wires as needed to provide controlled energy delivery through the ablation structure 101. In one embodiment, the electrical connections 109 include low electrical loss wires such as litz wire.

[00168] The inflation line 113 is arranged and configured to transport an expansion medium, typically a suitable fluid or gas, to and from the inflation member. In one embodiment, the inflation line is a flexible tube. The inflation line 113 can be made of polymer or co-polymers, such as the non-limiting examples of polyimide, polyurethane, polyethylene terephthalate (PET), or polyamides (nylon). The inflation member 105 is designed to deflect the ablation device 100 in relation to a target tissue surface 3. The inflation member 105 can be reversibly expanded to an increased profile.

[00169] In one embodiment, the inflation member 105 additionally serves as an attachment site for support of the ablation device 100 by an endoscope 111. As shown in **Figures 9 – 14, 17, 18, 21 and 22**, the inflation member 105 can be deployed from a low profile configuration or arrangement (see **Figures 10, and 20**) to an increased profile configuration or arrangement (see **Figures 11-14, 17- 19**) using the expansion medium. In preparation for ablation, when the inflation member 105 is sufficiently inflated, deflection of the ablation device 100 in relation to a tissue surface 3 can be achieved. As shown in **Figures 11, 31, 42, and 44**, in one embodiment, deflection of the ablation device 100 results in a therapeutic level of contact, *i.e.*, a substantially direct, uniform, and sustainable contact between the ablation structure 101 of the device 100 and the target tissue surface 3. For example, as shown in **Figures 31, 42, and 44**, when the inflation member 105 is sufficiently inflated, the resulting expanded profile of the inflation member 105, which contacts the tissue surface 3, results in contact by deflection between the tissue surface 3 of the inner wall of a luminal organ bypass-reconstructed gastrointestinal tract 5 and the ablation structure 100. In these embodiments, suction can be applied in combination with the inflation member 105 to achieve contact between the ablation structure 101 and the tissue surface 3. Suction can be achieved through the endoscope 111 or through the ablation device 100 to aid in collapsing the targeted tissue surface 3 around the ablation structure 101.

[00170] In various embodiments, the inflation member 105 may be compliant, non-compliant or semi-compliant. The inflation member 105 can be made of a thin, flexible, bladder made of a material such as a polymer, as by way of non-limiting examples, polyimide, polyurethane, or polyethylene terephthalate (PET). In one embodiment, the inflation member is a balloon. Inflation of the inflation member 105 can be achieved through the inflation line 113 using, for example, controlled delivery of fluid or gas expansion medium. The expansion medium can include a compressible gaseous medium

such as air. The expansion medium may alternatively comprise an incompressible fluid medium, such as water or a saline solution.

[00171] As shown in **Figures 12, 13, and 14**, the inflation member **105** can be configured and arranged in a variety of ways to facilitate deflection of the ablation device **100** in relation to a tissue surface **3**. For example, as shown in **Figure 12**, the inflation member **105** can be eccentrically positioned in relation to the supporting endoscope **111** as well as the housing **107** and the ablation structure **101**. Alternatively, as shown in **Figure 13**, the inflation member **105** can be positioned concentrically in relation to the supporting endoscope **111** and the ablation structure **101** can be attached to the inflation member **105** distally from the endoscope **111**. In another embodiment, as shown in **Figure 12**, the inflation member **105** can be positioned between the supporting endoscope **111** and the ablation structure **101**. The ablation structure **101** shown in **Figures 12 – 14** can cover a range of circumferential span of the endoscope **111** spanning, for example, from about 5 to 360 degrees when inflation member **105** is deployed.

[00172] One method of ablating tissue in a luminal organ of the bypass-reconstructed gastrointestinal tract can include a first step of advancing an ablation structure **101**, into the bypass-reconstructed gastrointestinal tract. In a second step, the ablation structure **101** is supported with an endoscope **111** within the bypass-reconstructed gastrointestinal tract. In a third step, the ablation structure **101** is deflected toward a tissue surface **3**. In a fourth step, energy can be applied to the ablation structure **101** to ablate the tissue surface **3**.

[00173] In another method, the step of advancing an endoscope-supported ablation structure **101** can include advancing the endoscope **111** into a luminal organ of the bypass-reconstructed gastrointestinal tract and advancing the ablation structure **101** over the endoscope **111**. For example, the endoscope **111** can be positioned relative to an ablation target tissue surface **3** after which the ablation structure **101** can be advanced over the outside of the endoscope **111** for ablating the target tissue surface **3**.

[00174] In a further method, the step of supporting the ablation structure **101** with an endoscope **111** includes inserting the endoscope **111** into the ablation structure **101** (see for example, **Figures 1A – 2B**). In a related method, the ablation structure **101** is supported by a sheath **103** (see **Figures 26 – 28, 30, 31, 32 and 37**) and the step of inserting the endoscope **111** into the ablation structure **101** includes inserting the endoscope **111** into the sheath **103**. In a further related method, the step of inserting the endoscope **111** into the sheath **103** includes creating an opening in the sheath **103** (not shown).

[00175] In a particular method, a distal portion of a sheath **103** having a smaller outer diameter than a proximal portion of the sheath **103**, is adapted to be expanded when an endoscope **111** is inserted into it.

[00176] In another method, the step of advancing the ablation structure **101** into the bypass reconstructed gastrointestinal tract includes advancing the ablation structure **101** through a channel of the endoscope **111** from either the endoscopes proximal or distal end (as discussed below for **Figures**

34A, 35A and 36A). In yet another method, the step of supporting the ablation structure **101** comprises supporting the ablation structure **101** with a channel of the endoscope (see as discussed below for **Figures 34A, 35A, 36A, 37 – 39**). In a further method, a deflection structure or deflection member **150** is advanced through a channel of the endoscope **111** and the step of deflecting the ablation structure **101** toward a tissue surface **3** includes deflecting the ablation structure **101** with the deflection structure or deflection member **150**.

[00177] As illustrated in **Figures 34A, 35A, and 36A**, variously adapted and configured ablation structures **101** can fit within and be conveyed through an endoscope internal working channel **211**. In each case, the ablation structure **101** and an accompanying deflection mechanism can be conveyed through the internal working channel **211** in a dimensionally compacted first configuration that is capable of expansion to a second radially expanded configuration upon exiting the distal end **110** of the endoscope **111** (For example, see **Figures 34A, 34B, 35A, 35B, 36A, and 36B**).

[00178] As shown in **Figure 34B**, in one embodiment, the deflection mechanism is an inflation member **105**, to which the ablation structure **101** can be integrated within or mounted/attached to, for example by etching, mounting or bonding. The inflation member **105** can be, for example, a compliant, non-compliant or semi-compliant balloon.

[00179] As shown in **Figures 35B and 35B**, in another embodiment, the deflection mechanism is an expandable member **209** that can expand to a second desired arrangement and configuration. As shown in **Figure 35B**, the expandable member **209**, can be an expandable stent, frame or cage device, to which an ablation structure **101** is mounted or integrated. For example, where the expandable member **209** is a wire cage, the wires can be a component of a bipolar circuit to provide the ablation structure **101** feature. Alternatively, the cage can have a flexible electrode circuit bonded or can be attached to an outer or inner surface of the cage to provide an ablation structure **101** that is an electrode. As shown in **Figure 36B**, the expandable member **209**, can be a folded or rolled series of hoops including or having an attached ablation structure **101** that expands upon exiting the endoscope distal end **110**.

[00180] As further illustrated in **Figures 37 – 39**, the ablation structure **101** can be supported with a channel of the endoscope **111**. In one embodiment as shown in **Figures 37 – 39**, an ablation device **100** includes a deflection member **150** that supports an attached housing **107** and ablation structure **101**. As shown in **Figure 39**, the endoscope **111** includes an internal working channel **211** suitable for advancing or retreating the deflection member **150** which is connected to an internal coupling mechanism **215** of the ablation device **100**. **Figures 37 and 39** both show a deflection member **150** including a bent region of the deflection member **150** in a deployed position, wherein the deflection member **150** bent region is positioned external to the endoscope distal end **110**. **Figure 38** shows the deflection member **150** in an undeployed position, wherein the deflection member **150** bent region is positioned internal to the endoscope **111**. The ablation structure **101** is thus supported with a channel

of the endoscope 111 (the internal working channel 211 of the endoscope 111) by way of the deflection member 150 and the connected internal coupling mechanism 215 of the ablation device 100.

[00181] In addition, when the deflection member 150 is advanced or moved proximally or distally within the endoscope internal working channel 211, the deflection member 150 is accordingly advanced through a channel of the endoscope 111. In another implementation, as shown in **Figure 42**, wherein the deflection mechanism is an inflatable member 105 (shown in a deployed configuration) coupled to an inflation line 113, the inflation line 113 can be disposed within the endoscope internal working channel 211. In yet another implementation, both the inflatable member 105 (in an undeployed configuration) and inflation line 113 can be advanced within the internal working channel 211 either proximally or distally in relation to the endoscope 111. Conductive wires 109 can pass through the working channel (not shown) or outside as shown in **Figure 37**.

[00182] As shown in **Figure 41**, in another implementation the endoscope 111 includes an internal working channel 211 suitable for supporting the ablation housing 107 and ablation structure 101 which are connected to an internal coupling mechanism 215 of the ablation device 100. As such, the connected ablation structure 101 is supported within a channel of the endoscope 111. Additionally as shown in **Figure 41**, the housing 107 and ablation structure 101 can further be supported by an external region of the endoscope 111, wherein the internal coupling mechanism 215 is adapted and configured to position the housing 107 in contact with the external region of the endoscope 111. The internal coupling mechanism 215 can be cannulated (not shown) to facilitate use of the working channel to aspirate and flow in fluids or air.

[00183] In another ablation method, an additional step includes moving the ablation structure 101 with respect to the endoscope 111 within a luminal organ of the bypass-reconstructed gastrointestinal tract. As illustrated in **Figures 27, 28, 30, 32, and 47**, and as discussed below, a sheath 103 of the ablation device 100 to which the ablation structure 101 is attached can enable moving the ablation structure 101 with respect to the endoscope 111. Further, as illustrated in **Figures 34A, 35A, 36A, 37, 38, 39, and 41**, and discussed above, an internal working channel 211 of the endoscope 111 through which at least a part of the ablation device 100 is disposed can enable moving the ablation structure 101 with respect to the endoscope 111.

[00184] Referring to **Figures 11, 31, 42, and 44**, in yet another method, the step of deflecting the ablation structure 101 toward a tissue surface 3 includes inflating an inflation member 105 of the ablation device 100 within a luminal organ of the bypass-reconstructed gastrointestinal tract. The inflation member 105 can be arranged and configured to be reversibly inflatable. The inflation member 105 can be inserted along with the ablation structure 101 into an alimentary tract in a collapsed configuration and expanded upon localization at a pre-selected treatment area. In one implementation, the inflation member 105 is a balloon. For example, in **Figures 11, 31, 42, and 44** it

is shown how deflecting the ablation structure **101** toward a tissue surface **3** is achieved when the inflation member **105** is inflated or deployed. As illustrated in **Figures 11, 31, 42, and 44**, upon sufficient inflation, the inflation member **105** contacts a tissue surface **3** consequently deflecting the ablation structure **101** which contacts an opposing tissue surface **3**.

[00185] As shown in **Figures 19B, 20, 35, 36** and discussed above, in a further method, the step of deflecting the ablation structure **101** includes expanding a deflection structure or deflection member **150**. In one implementation, as shown in **Figure 19A** the ablation device **100** includes a sheath **103**, wherein the sheath **103** is arranged and configured to receive the deflection member **150**, the endoscope **111** and ablation structure **101** internally to the sheath **103**. In one implementation, the deflection member **150** is a shape memory alloy, for example, Nitinol. The flexible extensions of the deflection member **150** in this embodiment can be coupled to the endoscope, an elastomeric sheath **115** of the ablation device **100** (shown in **Figure 19A**) or any part of the device **100**, including the ablation housing **107**.

[00186] As shown in **Figures 34, 35, 36, 37, 38, and 39**, and discussed above, in a further method, the step of deflecting the ablation structure **101** includes moving a deflection structure or deflection member **150**.

[00187] Briefly, in each case moving the deflection **150** is used to change the deflection member **150** from a non-deployed to a deployed configuration. As shown in **Figure 23**, in one embodiment, deflecting the ablation structure **101** includes a flexing point in the ablation structure **101**, wherein the ablation structure **101** can deflect in response to, for example, resistance met in contacting a tissue surface **3**.

[00188] As shown in **Figures 43, 44, and 45A – 45C** and as discussed in further detail below, in another method, the step of deflecting the ablation structure **101** includes rotating, pivoting, turning or spinning the ablation structure **101** with respect to the endoscope **111** along their respective and parallel longitudinal axes. Deflection of the ablation structure **101** with respect to the endoscope **111** can occur in combination with the endoscope **111** distal end **110** deflecting with respect to a target site on the wall of an luminal organ of the bypass-reconstructed gastrointestinal tract or without. Also, the ablation structure **101** can deflect in combination with an inflation member **105** used to achieve apposition of the ablation device **100** to the tissue. In some embodiments, the step of deflecting the ablation structure **101** may additionally include any combination of the above disclosed deflecting steps.

[00189] As shown in **Figures 19, 20, 21, 22, 34A, 34B, 35A, 35B, 36A, 36B, 46B, and 47**, in another ablation method, an additional step includes moving the ablation structure **101** from a first configuration to a second radially expanded configuration. The details regarding radial expansion of the ablation structure **101** shown in **Figures 19, 20, 21, and 22** are described below, while the details for **Figures 34A, 34B, 35A, 35B, 36A, and 36B** are described above. Additionally, as shown in

Figures 46B and 47 the ablation structure **101** can be arranged in a first configuration wherein the ablation structure **101** is coupled directly or alternatively through an housing **107** (not shown) to an inflation member **105** attached to a catheter **254**. In an undeployed configuration as shown in **Figures 46B and 47**, the non-inflated inflation member **105** and ablation structure **101** have a relatively low profile in relation to the endoscope **111**. When deployed, the inflation member **105** moves the ablation structure **101** to a second radially expanded configuration (not shown).

[00190] As shown in **Figures 15, 16, 40, 43, 44, 45A – 45C, 46B, and 47**, in a further method, an additional step includes attaching the ablation structure **101** to the endoscope **111**. As shown in **Figures 15 and 16**, attachment of the ablation structure **101** to the endoscope **111** can also be by way of an elastomeric sheath **115**. The elastomeric sheath **115** can removably hold the ablation structure **101** in a desired position on the endoscope **111**. The elastomeric sheath **115** can be arranged and configured to fit over the endoscope distal end **110**. As shown in **Figures 15 and 16**, the inflation member **105** can be attached to the elastomeric sheath **115** or alternatively the inflation member **105** can also act as the "elastomeric sheath" (not shown).

[00191] In another method, the step of attaching the ablation structure **101** to the endoscope **111** includes attaching the ablation structure **101** to an outside surface of the endoscope. Alternatively, the attaching step can include, for example, attaching to an inside surface, an outside or inside feature of the endoscope, or any combinations of the above. Lubricants such as water, IPA, jelly, or oil may be used to aid attachment and removal of the ablation device from the endoscope.

[00192] As shown in **Figure 41**, in a further method, the step of attaching the ablation structure **101** to the endoscope **111**, includes an ablation structure **101** having an attached rolled sheath **116**, wherein attaching the ablation structure **101** to the endoscope **111** includes unrolling the sheath **116** over an outside surface of the endoscope **111**. The rolled sheath **116** can additionally cover the electrical connections **109** of the ablation device **100** along a length of the endoscope **111** (see **Figure 41**). In a related method, the ablation structure **101** is attached to the endoscope **111** by an attaching step including unrolling the rolled sheath **116** over an outside surface of the endoscope **111** and part of the ablation structure **101**.

[00193] In another method, as shown in **Figure 40**, the step of attaching the ablation structure **101** to the endoscope **111** includes attaching the ablation structure **101** to a channel of the endoscope. As shown in **Figure 40**, in one implementation, the housing **107** and ablation structure **101** are coupled to an internal coupling mechanism **215** that can be positioned within an internal working channel **211** of the endoscope **111**. The internal coupling mechanism **215** in **Figure 40** is shown as attached to the internal working channel **211** at the endoscope distal end **110**. In this embodiment, the housing **107** and ablation structure **101** are shown in alignment with and coupled to an outside surface of the endoscope **111** near the distal end **110**.

[00194] In one method of ablating tissue in the alimentary tract, the tissue surface 3 can include a first treatment area and activation of the ablation structure 101 step can include activation of the ablation structure 101 to ablate the first treatment area, and further include moving the ablation structure 101 to a second area without removing the ablation structure 101 from the patient and activating the ablation structure 101 to ablate the second tissue area 3. Moving, in this sense, refers to moving the ablational structure to the locale of a target site, and thereafter, further moving of the structure into a therapeutically effected position can be performed variously by inflating a balloon member, or deflection or inflating a deflection member, as described in detail elsewhere. For example, where two or more areas of the tissue surface 3 of a target area in the wall of an organ in the bypass-reconstructed gastrointestinal tract can be ablated by directing the ablation structure 101 to the first target region and then activating the ablation structure 101 to ablate the tissue surface 3. Then, without removing the ablation structure 101 from the patient, the ablation structure 101 can be directed to the second target area in the wall of an organ for ablation of the appropriate region of the tissue surface 3.

[00195] In general, in another aspect, an ablation device 100 is provided that includes an ablation structure 101 removably coupled to an endoscope distal end 110, and a deflection mechanism adapted and configured to move the ablation structure 101 toward a tissue surface 3 (see for example, **Figures 5 – 19, 22, 22, 27 – 29, 30 – 32, 34A, 35A, 36A, 37, 38, 39, 42, 44, and 47**).

[00196] In a related embodiment, the ablation device 100 additionally includes an ablation structure movement mechanism adapted to move the ablation structure 101 with respect to the endoscope 111. As discussed below and shown in **Figures 26 – 28, and 30 – 32**, the ablation structure movement mechanism can be a sheath 103 to which the ablation structure 101 is attached, wherein the sheath 103 is arranged and configured to move the ablation structure 101 with respect to an endoscope 111 received within the sheath 103. Alternatively, as discussed above and shown in **Figures 34A, 35A, 36A, and 37 – 39**, the ablation structure movement mechanism can be in the form of an internal coupling mechanism 215 of the ablation structure 100, wherein the ablation structure is connected to the internal coupling mechanism 215 and at least a portion of the internal coupling mechanism 215 is disposed internally to the endoscope.

[00197] In another embodiment, the ablation device 100 additionally includes a coupling mechanism designed to fit over an outside surface of an endoscope 111, to couple the ablation structure 101 with the endoscope 111. As discussed above, a spiral sheath 104, an elastomeric sheath 115, a rolled sheath 116 and an internal coupling mechanism as shown in **Figures 15, 16, 40, and 41** respectively, are examples of such coupling mechanisms. In a particular embodiment, the coupling mechanism includes a sheath 103 capable of supporting the ablation structure 101. The sheath 103 can be tubing, a catheter or other suitable elongate members. The sheath 103 can be arranged and configured so that it can be moved independently of an associated endoscope.

[00198] As shown in **Figure 41**, in another embodiment, the sheath **103** can be arranged and configured as a rolled sheath **116** that can be unrolled over the outside surface of the endoscope. In use, a rolled sheath **116** connected to the ablation device **100**, for example at substantially near the proximal end of the housing **107** (from the perspective of an operator of the device), can be unrolled from such a position and continue to be unrolled toward the proximal end **112** of the endoscope **111** (see **Figure 47**). In this way, the rolled sheath **116** can be caused to contact and cover all or a portion of the length of the endoscope **111** (not shown). Additionally, as the rolled sheath **116** is unrolled along the endoscope **111**, it can sandwich the electrical connections **109** between the rolled sheath **116** and the endoscope **111** (see generally **Figure 41**).

[00199] In another embodiment, as shown in **Figures 30 and 31**, the sheath **103** can be arranged and configured to support a deflection mechanism wherein the deflection mechanism includes a deflection structure or deflection member **150**. As illustrated in **Figures 30 and 31**, where the deflection member **150** is an inflation member **105**, the inflation member **105** can be directly attached to the sheath **103**. As shown in each case, the inflation member **105** is positioned opposite the placement of the ablation structure **101**, which is also attached to the sheath **103**. This configuration of the sheath **103** provides support for the inflation member **105** and the ablation structure **101** irrespective of the positioning of the endoscope distal end **110**. For example, as shown in **Figure 30**, the endoscope distal end **110** can be positioned to provide a gap between the distal end **110** and a distal end of the sheath **103** where the ablation structure **101** and inflation member **105** are positioned. In contrast, as shown in **Figure 31** the endoscope distal end **110** can extend through and beyond the distal end of the sheath **103**.

[00200] In another embodiment, as shown in **Figure 26**, the sheath **103** can be elongated. **Figure 26** illustrates a sheath including electrical connections **109** and an inflation line **113**. The sheath **103** may include pneumatic and/or over extruded wires impregnated within the sheath **103**. In use, the sheath **103** can be introduced first into an alimentary tract, wherein the sheath **103** serves as a catheter like guide for introduction of the endoscope **111** within the sheath **103**. Alternatively, the endoscope **111** may be introduced first and thereby serve as a guidewire for the sheath **103** to be introduced over. **Figure 26** also shows attachment of an inflation member **105** to the sheath **103**, in an arrangement wherein the ablation structure **101** is attached to the inflation member **105** opposite the sheath **103** attachment point.

[00201] In embodiments shown in **Figures 27 and 28**, the sheath **103** includes an optically transmissive portion **158** adapted and configured to cooperate with a visual channel of an endoscope **111**. For example, the sheath **103** may be made of clear, translucent or transparent polymeric tubing including PVC, acrylic, and Pebax® (a polyether block amide). As shown in **Figure 24**, one component of an endoscope **111** can be a visual channel **161** that provides visual imaging of a tissue surface **3** as imaged from the endoscope distal end **110**. For example, the transmissive portion **158** can allow visualization of the wall of an esophagus **3** through the transmissive portion **158** of the sheath

103. As shown in **Figure 28** and in the cross-section view provided in **Figure 29**, the sheaths **103** shown in **Figures 27 and 28**, include an optically transmissive portion **158** arranged and configured to provide viewing of tissue surfaces **3** through the wall of the sheath **103**, with the aid of an internally disposed endoscope **111** having a visual channel **161**. Also shown in cross-section in **Figure 29** are portions of the sheath **103** through which electrical connections **109** and an inflation line **113** can pass. These features may be imbedded into the sheath **103** inner-wall or attached to the sheath **103** inner wall. As shown in **Figure 27**, the sheath **103** including a transmissive portion **158** can extend past the endoscope distal tip **110**. Alternatively, as shown in **Figures 27, 28, and 31**, the endoscope distal end **110** can extend distally past the transmissive portion **158** of the sheath **103**.

[00202] In another implementation, the transmissive portion **158** of the sheath **103** can be reinforced structurally with coil or braid elements incorporated therein to prevent ovalization and/or collapsing of the sheath **103**, particularly while deflecting the ablation device **100**

[00203] In a further embodiment, the sheath **103** includes a slit **203** formed in a proximal portion of the sheath **103**, the slit **203** being designed to open to admit an endoscope distal end **110** into the sheath **103**. As shown in **Figure 32** the proximal portion of the sheath **103** can include a perforation region or slit **203**. The slit **203** can extend partially or fully along the length of the sheath **103**. The slit **203** enables the sheath **103** to be pulled back, or opened when, for example introducing an endoscope **111** into the sheath **103**. In one implementation, as shown in **Figure 32**, the sheath **103** additionally includes a locking collar **205** for locking the sheath **103** in a desired position in respect to the endoscope **111**.

[00204] As shown in **Figures 33A and 33B**, the distal portion of the sheath **103** can have a smaller outer diameter than a proximal portion of the sheath **103**, the distal portion of the sheath **103** being adapted and configured to be expanded when an endoscope **111** is inserted into it (not shown). This embodiment can aid in accessing an endoscope **111** in a case where the sheath **103** is advanced first into a target site within the alimentary tract. Since the distal end of the sheath **103** is smaller in diameter, but includes a slit **203**, the sheath **103** can accept a larger outside diameter endoscope **111** because when the endoscope **111** is advanced, the slit **203** of the sheath **103** allows for widening of the sheath **103**.

[00205] In general, in another aspect, a method of ablating tissue in within the alimentary tract includes advancing an ablation structure **101** into the alimentary tract while supporting the ablation structure **101** with an endoscope **111**. The endoscope distal end **110** can be bent to move the ablation structure **101** into contact with a tissue surface followed by activation of the ablation structure **101** to ablate the tissue surface **3** (see *e.g.*, **Figure 43**). In a particular embodiment, the ablation structure **101** includes a plurality of electrodes and the activating step includes applying energy to the electrodes.

[00206] In general, in another aspect the coupling mechanism is designed to fit over an outside surface of an endoscope **111**, to couple the ablation structure **101** with the endoscope **111**, rather than

being for example, a sheath (as discussed above), and is adapted and configured to provide a certain freedom of movement to the ablation structure 101, including but not limited to flexing and/or rotating and/or pivoting with respect to the endoscope 111 when coupled to the endoscope 111. The freedom of movement is with respect to one, two, or three axes, thereby providing one, two, or three degrees of freedom. Non-limiting examples of suitable coupling mechanisms include a flex joint, pin joint, U-joint, ball joint, or any combination thereof. The following described coupling mechanism embodiments advantageously provide for a substantially uniform apposition force between a supporting endoscope 111 and an ablation structure 101 when localized at a target tissue surface 3.

[00207] As shown in Figures 43, 44, 45A, and 45B, the coupling mechanism can be a ring 250 attached to the housing 107 and the endoscope 111, wherein the housing 107 is adapted and configured to flex, rotate or pivot about the ring 250. For example, as illustrated in Figure 43, where the ablation device 100 is coupled to a deflectable distal end 110 of an endoscope 111 by a ring 250, when the device 100 is deflected toward the tissue surface 3 of the wall of the lumen of a bypass-reconstructed gastrointestinal organ, the housing 107 upon contact aligns the ablation structure 101 with the tissue surface 3 by flexing, rotating or pivoting about the ring 250 coupling. In these embodiments, the endoscope and the housing that supports the ablation structure both have their own longitudinal axis, and these axes are situated parallel to each other. The coupling mechanism that attaches the housing to the endoscope allows a pivoting movement between the longitudinal axis of the housing and the longitudinal axis of the endoscope. Advantageously, sufficient contact pressure provided by deflection of the distal end 110 of the endoscope 101 can produce a desired degree of contact between the ablation structure 101 and the tissue surface 3, irrespective of the precise alignment of the distal end 112 in respect to a plane of the tissue surface 3 to be treated.

[00208] For the purposes of this disclosure, a "desired degree of contact", "desired contact", "therapeutic contact", or "therapeutically effective contact" between the ablation structure 101 and the tissue surface 3, includes complete or substantially-complete contact between all or a portion of a predetermined target on the tissue surface 3 (e.g. a site on the wall of a luminal organ of the bypass-reconstructed gastrointestinal tract) by all or a portion of the ablation structure 101. It should also be understood that therapeutic contact, as described in this disclosure typically occurs as a consequence of an ablational surface on an apparatus having been moved into such contact by the expansion of an expandable member such as a balloon, or by expanding, moving, or deflecting a deflection structure. By all such approaches, such movement or bringing into therapeutic contact includes the exertion or application of pressure. Such pressuring is a factor in effecting coaptive ablation, wherein pressure exerted through tissue on blood vessels causes them to be partially or substantially emptied of blood, and coincidentally serves as a counter-pressure that prevents entry of blood normally brought about by blood pressure. Thus, any occurrence of moving or expanding a member so as to bring an ablation surface against target tissue can also be understood as pressuring the tissue.

[00209] As shown in **Figure 44**, in a different yet related embodiment, where the deflection mechanism of the ablation device **100** is an inflatable member **105**, a ring **250** coupling allows for flexing, rotating or pivoting of the housing **107** and ablation structure **101**. As in the previous case, sufficient contact pressure provided through deflection, here by the inflatable member **105**, can produce a desired degree of contact between the ablation structure **101** and the tissue surface **3**. Again, advantageously, the desired contact can be achieved irrespective of the precise alignment of the deflected endoscope **111** distal end **110** in respect to a plane of the tissue surface **3** to be treated, because of the flexing, rotating or pivoting provided by the ring **250** coupling.

[00210] As shown in **Figure 45A**, in a related embodiment, the coupling mechanism between the ablation device **100** and an endoscope **111** can be an elastic band **252**, wherein the housing **107** of the device **100** is flexibly coupled to the elastic band **252**. For example, as illustrated in **Figure 45C**, where the ablation device **100** is coupled to a distal end **110** of an endoscope **111** by an elastic band **252**, when the device **100** is deflected toward a tissue surface **3** of the wall of a luminal organ of the bypass-reconstructed gastrointestinal tract, alignment between the housing **107** and accordingly the ablation structure **101** and the tissue surface **3**, can be achieved by flexing about the elastic band **252** coupling. Once more, advantageously, the desired contact can be achieved irrespective of the precise alignment of the deflected endoscope's **111** distal end **110** in respect to a plane of the tissue surface **3** to be treated, because of the flexing capability provided by the elastic band **252** coupling.

[00211] As shown in **Figure 45A**, in another related embodiment, the coupling mechanism between the ablation device **100** and an endoscope **111** can be a combination of a ring **250** and an elastic band **252**, wherein the housing **107** of the device **100** is coupled to the elastic band **252**. For example, as illustrated in **Figure 45A**, where the ablation device **100** is coupled to a distal end **110** of an endoscope **111** by an elastic band **252**, when the device **100** is deflected toward a tissue surface **3** of, for example, the wall of a luminal organ of the bypass-reconstructed gastrointestinal tract (not shown), alignment between the housing **107** and accordingly the ablation structure **101**, and the tissue surface **3** by flexing, rotating or pivoting about the ring **250** and the elastic band **252** coupling can be achieved. Again, advantageously, the desired contact can be achieved irrespective of the precise alignment of the deflected endoscope **111** distal end **110** in respect to a plane of the tissue surface **3** to be treated, because of the flexing rotating or pivoting provided by the elastic band **252** coupling.

[00212] In another embodiment, the ablation device **100** additionally includes an alternative coupling mechanism between the ablation device **100** and an endoscope **111** that is arranged and configured to fit within a channel of an endoscope **111**. The coupling mechanism can be an internal coupling mechanism **215** and can be configured and arranged to couple the ablation structure **101** within an internal working channel **211** of an endoscope **111** (see **Figure 37** and as discussed above).

[00213] As shown in **Figures 34A, 34B, 35A, 35B, 36A, and 36B**, in one embodiment of such a coupling mechanism, the ablation structure **101** is adapted and configured to fit within the endoscope

internal working channel 211. Additionally, as shown in **Figures 34A, 34B, 35A, 35B, 36A, and 36B**, in a related embodiment, the deflection mechanism is also adapted and configured to fit within the endoscope internal working channel 211.

[00214] In each of the embodiments described above and shown in **Figures 34A, 34B, 35A, 35B, 36A, and 36B**, after expansion of the inflatable member 105 or expandable member 209 and subsequent treatment of a target tissue 3, the coupling means can further serve as a means to draw, pull or retrieve the ablation structure 101 and deflection mechanism back into the endoscope internal working channel 211. Furthermore, in addition to providing coupling of the ablation structure 101 with the endoscope internal working channel 112, the coupling mechanism can include electrical connections 109 to provide energy to the ablation structure 101.

[00215] In a related embodiment, again wherein the ablation device 100 additionally includes a coupling mechanism adapted and configured to fit within a channel of an endoscope 111, the coupling mechanism can include a shape memory member and the deflection mechanism can include a bent portion of the shape memory member. As shown in **Figures 37 – 39**, the coupling mechanism can be an internal coupling mechanism 215. As shown, the internal coupling mechanism 215 can be disposed within an endoscope internal working channel 211 and extend beyond the endoscope distal end 100. Additionally, the internal coupling mechanism 215 can be connected to a deflection mechanism that is a deflection member 150. The deflection member 150 can include a bent portion and can be connected to the housing 107. As shown in **Figure 38** and discussed above, the bent portion of the deflection member 150 can be disposed within the endoscope internal working channel 211, causing the ablation structure 101 to move into a non-deployed position. Upon advancing the internal coupling mechanism 215 toward the endoscope distal end 110, the shape memory nature of the deflection member 150 facilitates deployment of the ablation structure 101 to a position suitable for ablation.

[00216] In general, in one aspect, the ablation structure 101 of the ablation device 100 includes an optically transmissive portion 158 adapted and configured to cooperate with a visual channel of an endoscope 111. As shown in **Figures 27 – 31** and discussed above, the optically transmissive portion 158 can be a sheath 103 of the ablation device 100.

[00217] In one embodiment, the ablation structure 101 of the ablation device 100 is further adapted and configured to move from a first configuration to a second radially expanded configuration. As shown in **Figures 19 – 22**, the ablation structure 101 and housing 107 can be designed to reversibly move from a first less radially expanded configuration (see **Figures 20 and 21**) to a second radially expanded configuration useful for ablation. Foldable or deflectable configurations that provide for reversible radial expansion of the housing 107 and the ablation structure 101 can facilitate access to tissue surfaces because of reduced size. Additionally, foldable or deflectable configurations are helpful in regard to cleaning, introduction, retrieval, and repositioning of the device in the luminal organs of the bypass-reconstructed gastrointestinal tract.

[00218] The ablation device **100** shown in **Figures 19B and 20** includes an ablation structure actuator **152** arranged and configured to move the ablation structure **101** from the first configuration (see **Figure 20**) to a second radially-expanded configuration (see **Figure 21**). As shown (**Figures 19B and 20**), the actuator **152** can be elongate and designed to work with a receiver **154** arranged and configured to receive the actuator **152**. The actuator **152** can be a wire, rod or other suitable elongate structure. Alternatively, the actuator **152** can be a hydraulic actuation means with or without a balloon component. In a particular embodiment, the actuator **152** is a stiffening wire.

[00219] As illustrated in **Figure 20**, before the actuator **152** is disposed within the portion of receiver **154** attached to the housing **107**, both the housing **107** and the ablation structure **101** are in a first position having a first configuration. As illustrated in **Figure 21**, after the actuator **152** is partially or fully introduced into the receiver **154**, the housing **107** and the ablation structure **101** are consequently changed to a second radially expanded configuration relative to the first configuration. Introduction of the actuator **152** into the receiver **154** can force the portions of the housing **107** and ablation structure **101** flanking the receiver **154** to expand radially (see **Figure 19**). In one embodiment, the housing **107** is heat set in a flexed first configuration suitable for positioning the ablation device **100** near a target tissue surface **3**. After a target tissue surface **3** has been reached, the actuator **152** can be introduced into the receiver **154** to achieve the second radially expanded configuration which is useful for ablation of the tissue surface **3**.

[00220] In a related alternative embodiment, the housing **107** and ablation structure **101** include an unconstrained shape that is radially expanded and includes one or more flex points to allow for collapsed or reduced radial expansion when positioned distally to the distal end **110** of an endoscope **111** and compressed by an elastomeric sheath **115** (not shown).

[00221] As shown in **Figures 21 and 22**, in another embodiment, the ablation structure **101** of the ablation device **100** is adapted and configured to move from a first configuration to a second radially expanded configuration wherein the ablation device **100** further includes an expandable member **156**. The expandable member **156** can be positioned between the housing **107** and the endoscope **111**, where in unexpanded form, the ablation structure **101** is accordingly configured in a first configuration. Upon expansion of the expandable member **156**, the ablation structure **101** configuration is changed to a second radially expanded configuration (see **Figure 21**).

[00222] In one embodiment, the deflection mechanism of the ablation device **100** includes an inflatable inflation member **105**. As shown in **Figures 11, 21, 22, 25B, 27, 28, 30, 31, 34A, 34B, 42, 44, 46, and 47** and discussed above, the inflation member **105** can facilitate deflection of the device **100** in relation to a tissue surface **3**.

[00223] In another embodiment, the deflection mechanism includes an expandable member **156** (see **Figures 35B and 36B**, discussed in detail above). As shown in **Figure 35B**, the expandable member **209**, can be an expandable stent, frame or cage device. As shown in **Figure 36B**, the expandable

member 209, can be an expanded series of connected hoops that can be folded or rolled prior to expansion.

[00224] In another advantageous embodiment, the ablation device 100 further comprises a torque transmission member adapted and configured to transmit torque from a proximal end of the endoscope 111 to the ablation structure 101 to rotate the ablation structure 101 about a central axis of the endoscope 111. In a particular embodiment, the torque transmission member includes first and second interlocking members adapted to resist relative movement between the endoscope 111 and the ablation structure 101 about the central axis. As shown in **Figures 46B, 46C, and 47**, in one embodiment the first interlocking member is a key 258 and the second interlocking member is a keyway 256. In one embodiment, the first interlocking member is attached to a sheath 103 surrounding the endoscope 111 and the second interlocking member is attached to a catheter 254 supporting the ablation structure 101. For example, as shown in **Figures 46B, 46C, and 47**, the key 258 can be attached to a sheath 103 surrounding the endoscope 111 and the keyway 256 can be attached to a catheter 254 supporting the ablation structure 101. In a further related embodiment, the catheter 254 and sheath 103 are arranged and configured for relative movement along the central axis of the endoscope 111. The sheath 103 can be, for example, an elastomeric sheath wherein the key 258 is attached to the outside of the sheath 103 substantially along a longitudinal axis of the sheath 103 (see **Figure 46C**). In use, this embodiment provides for a 1-to-1 torque transmission of the ablation device 100 endoscope assembly 111 when the endoscope proximal end 112 is manipulated, while also providing for positioning of the ablation structure 101 either proximal or distal to the endoscope distal end 110 *in situ*. Additionally, the sheath 103 can be pre-loaded into the catheter 254 or loaded separately.

[00225] In general, in one aspect, an ablation device 100 is provided including an ablation structure 101, and a coupling mechanism adapted to removably couple the ablation structure 101 to a distal end 110 of an endoscope 111 and to permit the ablation structure 101 to rotate and/or pivot with respect to the endoscope when coupled to the endoscope. Various related embodiments wherein, for example, the coupling mechanism comprises a ring 250 and the ablation structure 101 is adapted to rotate and/or pivot about the ring 250; wherein the coupling mechanism comprises an elastic band 252 adapted to flex to permit the ablation structure 101 to rotate and/or pivot; wherein the ablation device 100 further includes a deflection mechanism adapted and configured to move the ablation structure 101 toward a tissue surface 3; and, wherein such a deflection mechanism includes an inflatable member, have been set out in detail above.

[00226] **Figure 56A and 56B** provide views of an ablational device with an ablational surface on a hinge 159 which acts in a manner similar to mechanism depicted in **Figure 43**, and which allows a free pivoting movement of the ablational surface between its longitudinal axis and the longitudinal axis of an endoscope. **Figure 56A** shows the device with the ablational surface 101 oriented in

parallel with the endoscope, the surface having made contact with the inner surface of a gastrointestinal luminal wall **5** at a desired target area. The ablation surface **101** is supported by a deflection member **150** that can be expressed from a working channel, and withdrawn back into a working channel within the endoscope. **Figure 56B** shows the device with the longitudinal axis of the ablational surface **101** oriented at about a right angle with respect to the longitudinal axis of the endoscope. This pivoting as a passive response of the ablational surface **101**, as it easily rotates on hinge **159** through a flexion range of 0 degrees (parallel to the endoscope **111**) to about 170 degrees. As shown, the angle of the surface is about 90 degrees with respect to the endoscope.

[00227] While most embodiments described herein have made use of radiofrequency energy as an exemplary ablational energy, and consequently have made use of electrodes as an energy transmitting element, it should be understood that these examples are not limiting with regard to energy source and energy delivery or transmitting elements. As also described herein, other forms of energy, as well as cryoablating approaches, may provide for ablation of target areas in such a manner that ablation is fractional or partial, as described herein, where some portions of target area tissue are ablated, and some portions of target area tissue are not substantially ablated.

Terms and Conventions

[00228] Unless defined otherwise, all technical terms used herein have the same meanings as commonly understood by one of ordinary skill in the art of ablational technologies and treatment for metabolic conditions and diseases, as well as those understood by one of ordinary skill in the art of bariatric surgeries. Specific methods, devices, and materials are described in this application, but any methods and materials similar or equivalent to those described herein can be used in the practice of the present invention. While embodiments of the invention have been described in some detail and by way of exemplary illustrations, such illustration is for purposes of clarity of understanding only, and is not intended to be limiting. Various terms have been used in the description to convey an understanding of the invention; it will be understood that the meaning of these various terms extends to common linguistic or grammatical variations or forms thereof. It will also be understood that when terminology referring to devices, equipment, or drugs that have been referred to by trade names, brand names, or common names, that these terms or names are provided as contemporary examples, and the invention is not limited by such literal scope. Terminology that is introduced at a later date that may be reasonably understood as a derivative of a contemporary term or designating of a hierarchal subset embraced by a contemporary term will be understood as having been described by the now contemporary terminology. Further, while some theoretical considerations have been advanced in furtherance of providing an understanding of, for example, the biology of metabolic disease, or the mechanisms of action of therapeutic ablation, the claims to the invention are not bound by such theory. Moreover, any one or more features of any embodiment of the invention can be combined with any one or more other features of any other embodiment of the invention, without departing from

the scope of the invention. Still further, it should be understood that the invention is not limited to the embodiments that have been set forth for purposes of exemplification, but is to be defined only by a fair reading of claims that are appended to the patent application, including the full range of equivalency to which each element thereof is entitled.

CLAIMS

1. A method of ablationally-treating tissue in a target area of a gastrointestinal tract feature formed by a bariatric procedure that has failed comprising:
delivering radiofrequency energy to a tissue surface in the target area, the target area being a contiguous radial portion of an anatomical structure formed or altered by the bariatric procedure; and
controlling the delivery of radiofrequency energy across the tissue surface in the target area and into tissue layers in the target area.
2. The method of claim 1 wherein bariatric procedure is any of a Roux-en-Y procedure, a biliopancreatic diversion, or a sleeve gastrectomy.
3. The method of claim 1 wherein the feature of a gastrointestinal tract formed by bariatric procedure is any of a gastric pouch, a stoma, or a gastric sleeve
4. The method of claim 3 wherein the feature of a gastrointestinal tract formed by bariatric procedure is a suture line of the gastric sleeve.
5. The method of claim 1 wherein delivering radiofrequency energy includes delivering radiofrequency energy from non-penetrating electrodes.
6. The method of claim 1 wherein controlling the delivery of radiofrequency energy across the tissue surface in the target area includes delivering sufficient radiofrequency energy to achieve ablation in one fraction of the tissue target surface and delivering insufficient radiofrequency energy to another fraction of the surface to achieve ablation.
7. The method of claim 6 wherein controlling the fraction of the target area surface that receives sufficient radiofrequency energy to achieve ablation includes configuring the electrode pattern such that some spacing between electrodes is sufficiently close to allow conveyance of a level of energy sufficient to ablate and other spacing between electrodes is insufficiently close to allow conveyance of the level of energy sufficient to ablate.
8. The method of claim 6 wherein controlling the fraction of the target area surface that receives sufficient radiofrequency energy to achieve ablation includes operating the electrode pattern such that the energy delivered between some electrodes is sufficient to ablate and energy sufficient to ablate is not delivered between some electrodes.
9. The method of claim 1 wherein controlling the delivery of radiofrequency energy into tissue layers includes controlling the delivery of radiofrequency energy from the tissue surface such that sufficient energy to achieve ablation is delivered to some layers and insufficient energy is delivered to other layers to achieve ablation.

10. The method of claim 1 wherein controlling the delivery of radiofrequency energy across the surface and into tissue layers in the target area is such that some fraction of the tissue volume is ablated and another fraction of the tissue volume is not ablated.
11. The method of claim 1 wherein controlling the delivery of energy into tissue layers consists of ablating a fraction of tissue in the epithelial layer.
12. The method of claim 1 wherein controlling the delivery of energy into tissue layers consists of ablating a fraction of tissue in the epithelial layer and the lamina propria.
13. The method of claim 1 wherein controlling the delivery of energy into the tissue layers consists of ablating a fraction of tissue in the epithelial layer, the lamina propria, and the muscularis mucosae.
14. The method of claim 1 wherein controlling the delivery of energy into tissue layers consists of ablating a fraction of tissue in the epithelial layer, the lamina propria, the muscularis mucosae, and the submucosa.
15. The method of claim 1 wherein controlling the delivery of energy into the depth of the tissue consists of ablating a fraction of tissue in the epithelial layer, the lamina propria, the muscularis mucosae, the submucosa, and the muscularis propria.
16. The method of claim 1 wherein controlling the delivery of radiofrequency energy across the tissue surface and into tissue layers causes fractional ablation in tissue layers of the gastrointestinal tract.
17. The method of claim 1 wherein delivering energy includes delivering energy from an electrode pattern configured circumferentially through 360 degrees around the ablation structure.
18. The method of claim 17 wherein delivering energy from the ablation structure includes transmitting energy asymmetrically through the 360 degree circumference such that ablation is focused in an arc of less than 360 degrees.
19. The method of claim 1 delivering energy includes delivering energy from an electrode pattern configured circumferentially through an arc of less than 360 degrees around the ablation structure.
20. The method of claim 1 further comprising evaluating the target area at a point in time after the delivering energy step to determine the status of the area.
21. The method of claim 20 wherein the evaluating step occurs in close time proximity after the delivery of energy, to evaluate the immediate post-treatment status of the site.
22. The method of claim 20 wherein the evaluating step occurs at least one day after the delivery of energy.
23. The method of claim 1 wherein the delivering energy step is performed more than once.
24. The method of claim 1 further comprising deriving energy for transmitting from an energy source that is controlled by a control system.

25. The method of claim 24 wherein the energy source is a generator
26. The method of claim 24 further comprising feedback controlling the energy transmission so as to provide any of a specific power, power density, energy, energy density, circuit impedance, or tissue temperature.
27. The method of claim 1 further comprising:
 - advancing an ablation structure into the alimentary canal, the non-penetrating electrode pattern on the structure, the structure supported on an instrument;
 - positioning the ablation structure adjacent to the target area; and
 - moving the ablation structure toward the surface of the target area to make therapeutic contact on the target area prior to delivering energy.
28. The method of claim 27 wherein the moving step includes inflating a balloon member.
29. The method of claim 27 wherein the moving step includes expanding a deflection member.
30. The method of claim 27 wherein the moving step includes moving a deflection member.
31. The method of claim 27 wherein the moving step includes expanding an expandable member.
32. The method of claim 27 further including a position-locking step following the moving step.
33. The method of claim 32 the position-locking step includes developing suction between the structure and the ablation site.
34. The method of claim 27 further comprising evaluating the target area prior to the positioning step, the evaluating step to determine the status of the target area.
35. The method of claim 27 wherein multiple target areas are being treated, the method comprising the positioning, moving, and transmitting energy steps to a first target area, and further comprises the positioning, moving, and transmitting energy steps to another target area without removing the ablation structure from the patient.
36. An ablation system for treating a target area in tissue in a portion of a gastrointestinal tract formed by bariatric procedure comprising:
 - an electrode pattern including a plurality of electrodes;
 - a longitudinal support member supporting the electrode pattern;
 - a generator coupled to the plurality of electrodes;
 - a computer controller in communication with the generator, the controller having programming to direct the generator to deliver energy to the plurality of electrodes, the programming including the ability to direct delivery of energy to a subset of the electrodes, the electrodes of the pattern configured such that, when receiving energy from the generator and in therapeutic contact with a tissue target area, the electrodes ablate a portion of tissue in the target area and leave a portion of tissue in the target area non-ablated.

37. The ablation system of claim 36 wherein the portion of the gastrointestinal tract formed by the bariatric procedure includes any of a gastric pouch, a stoma, or a gastric sleeve.
38. The ablation system of claim 36 wherein the electrode pattern, having a longitudinal axis, forms a fully circumferential surface orthogonal to its longitudinal axis, the pattern sized for contacting tissue in a target area in the gastrointestinal tract.
39. The ablation system of claim 36 wherein the electrode pattern forms a partially circumferential surface orthogonal to its longitudinal axis, the pattern sized for contacting tissue in a target area in the gastrointestinal tract.
40. The ablation system of claim 39 wherein the electrode pattern forms an arc of about 180 degrees.
41. The ablation system of claim 39 wherein the electrode pattern forms an arc of about 90 degrees.
42. The ablation system of claim 36 wherein the electrode elements are distributed into a pattern such that when the programming directs the generator to deliver energy to all the electrodes, the electrode pattern, when therapeutically contacted to a target tissue area, ablates a portion of tissue in the target area and does not ablate another portion of tissue in the target area.
43. The ablation system of claim 35 wherein the programming directs the generator to deliver energy to a subset of electrode elements that form a pattern which, when therapeutically contacted to a target tissue area, ablates a portion of tissue in the target area and does not ablate another portion of tissue in the target area.
44. The ablation system of claim 43 wherein the portion of tissue which is ablated is rendered at least partially dysfunctional, and wherein the portion of the tissue which is not ablated retains its functionality.
45. An ablation system for treating targeted tissue in a target area of a gastrointestinal tract feature formed by a bariatric procedure that has failed comprising:
 - an ablation structure supported by an instrument,
 - an electrode pattern on the ablation support structure, the electrode pattern configured to control the delivery of energy to a target tissue such that a portion of the surface of the target area receives sufficient radiofrequency energy to achieve ablation and another portion of the surface of the target receives insufficient energy to achieve ablation;
 - means supported by the instrument by which to bring the ablation structure to gain therapeutic contact with tissue at the target area.
46. A method of treating a gastrointestinal tract feature formed by a bariatric surgical procedure that has become dilated comprising:
 - identifying a target area of the surgically-formed gastrointestinal feature;

- positioning a therapy device in the gastrointestinal tract adjacent to a target area on the dilated feature; and
- performing a non-surgical reduction therapy on the target area of the dilated feature.
47. The method of claim 46 wherein the identifying step is performed endoscopically.
48. The method of claim 46 wherein the identifying step, the positioning step, and the performing step are conducted during a single endoscopic procedure.
49. The method of claim 46 further comprising:
inserting an instrument having a reduction therapy device mounted thereon into the gastrointestinal tract before the identifying step; and
removing the instrument after the performing step.
50. The method of claim 46 wherein performing the non-surgical reduction therapy on the surgically-formed gastrointestinal feature includes applying energy to the target area.
51. The method of claim 50 wherein the energy is radiofrequency energy.
52. The method of claim 50 wherein applying energy to the target includes controlling the delivery of energy across the tissue surface in the target area.
53. The method of claim 50 wherein applying energy to the target area includes controlling the depth of delivery of energy into tissue layers in the target area.
54. The method of claim 50 wherein applying energy to the target area includes applying energy more than once.
55. The method of claim 50 wherein applying energy to the target area includes applying energy to more than one site on the gastrointestinal feature.
56. The method of claim 46 wherein performing a non-surgical reduction therapy surgically-formed gastrointestinal feature includes applying cryogenic treatment to the target area.
57. The method of claim 56 wherein applying the cryogenic treatment includes spraying a cryogenic fluid on the target area.
58. The method of claim 56 wherein applying the cryogenic treatment includes drawing heat from the target area into a cryogenic fluid contained in the device.
59. The method of claim 46 wherein the positioning step further includes moving an ablation structure of the device so as to make therapeutic contact with a target area on the dilated feature.
60. The method of claim 59 wherein moving the ablation structure includes any of inflating a balloon member, expanding a deflection member, moving a deflection member, or expanding an expandable member.

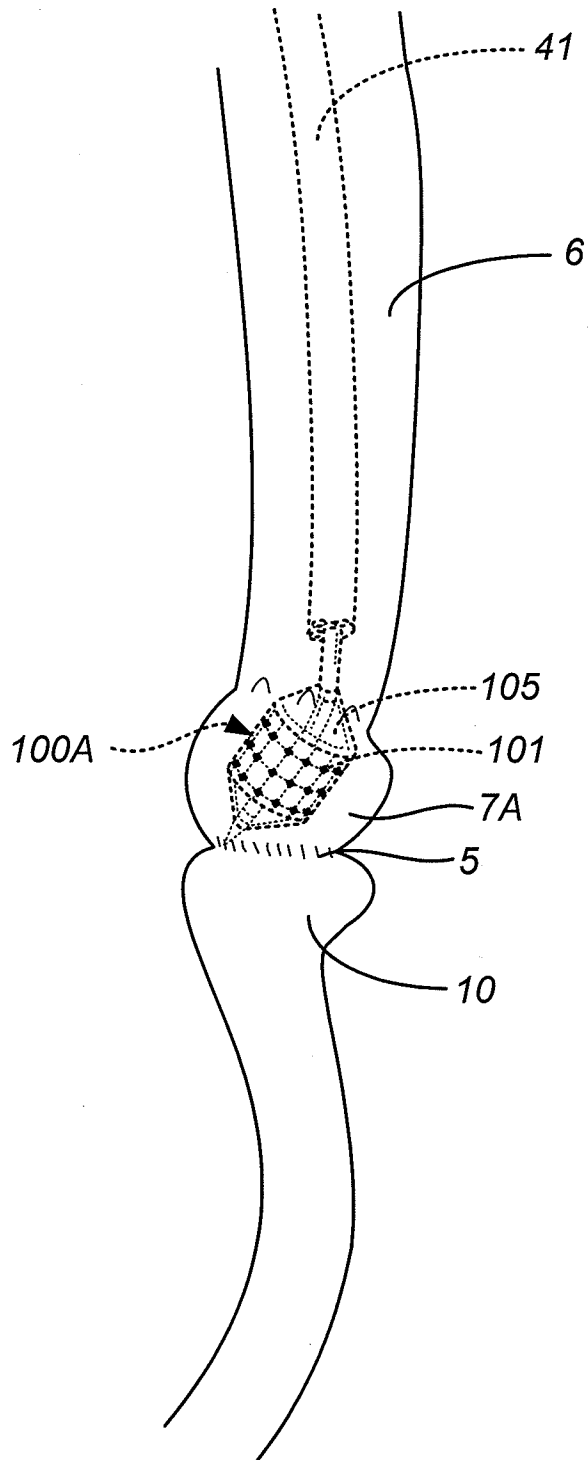

FIG. 1A

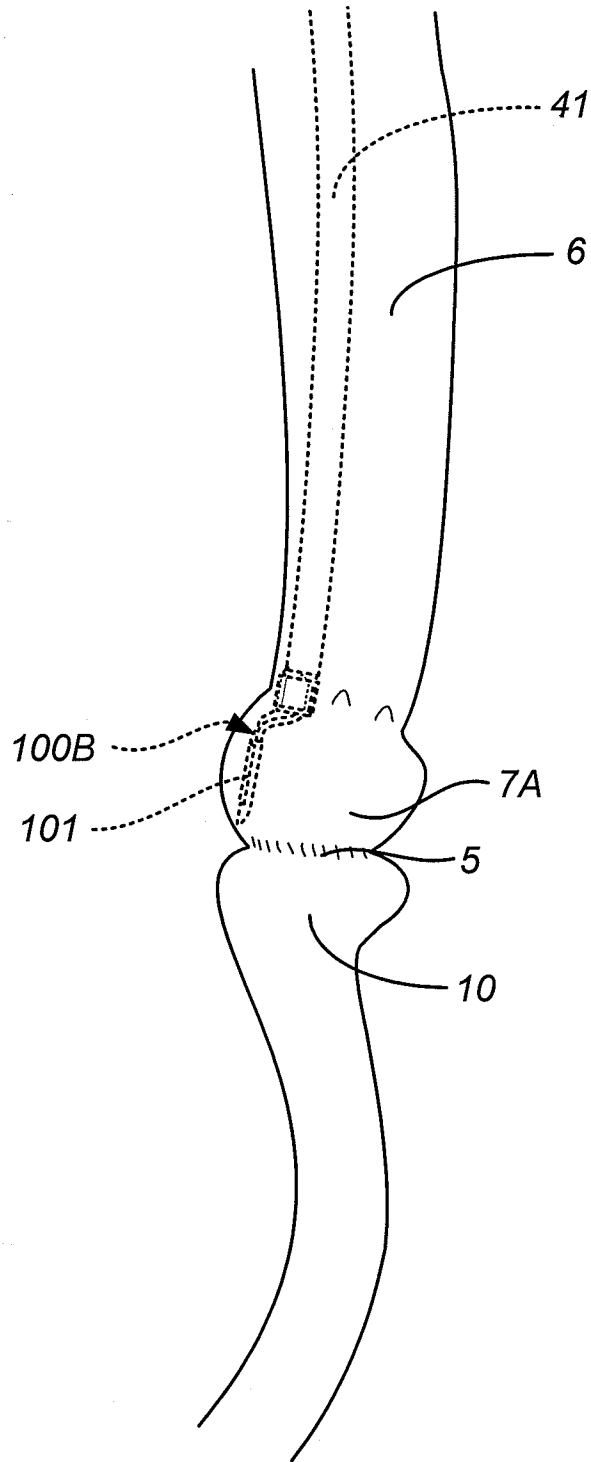

FIG. 1B

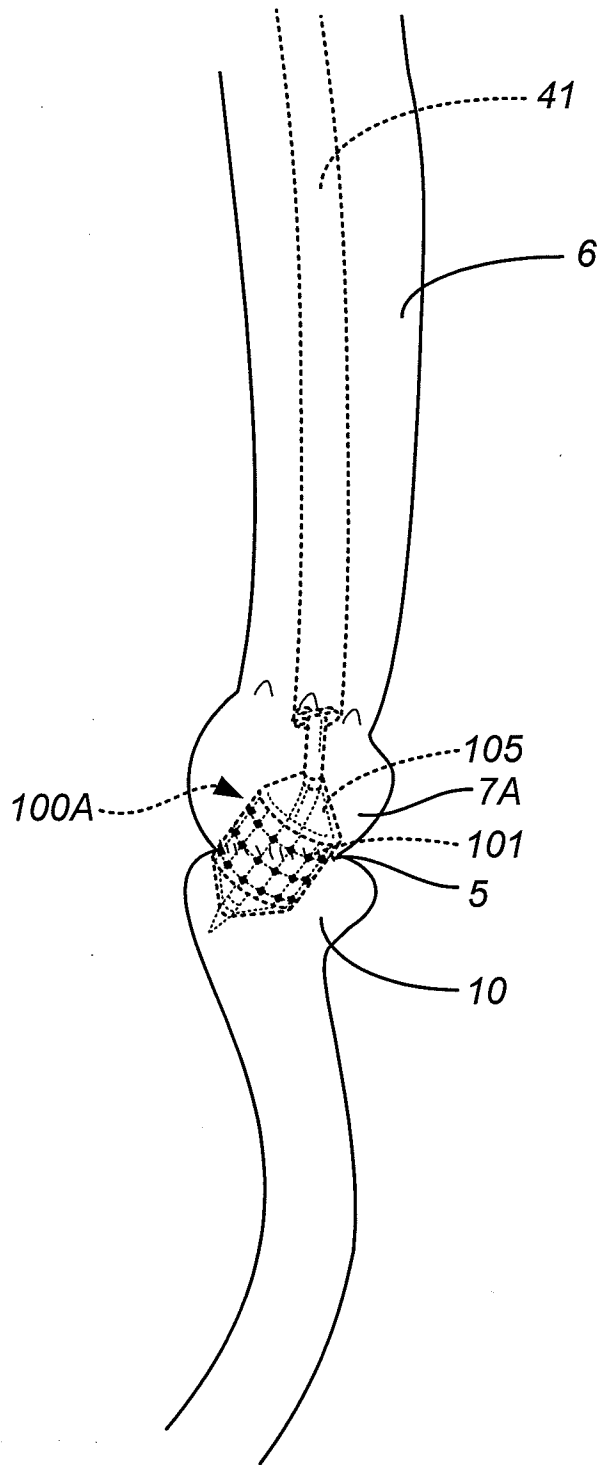

FIG. 1C

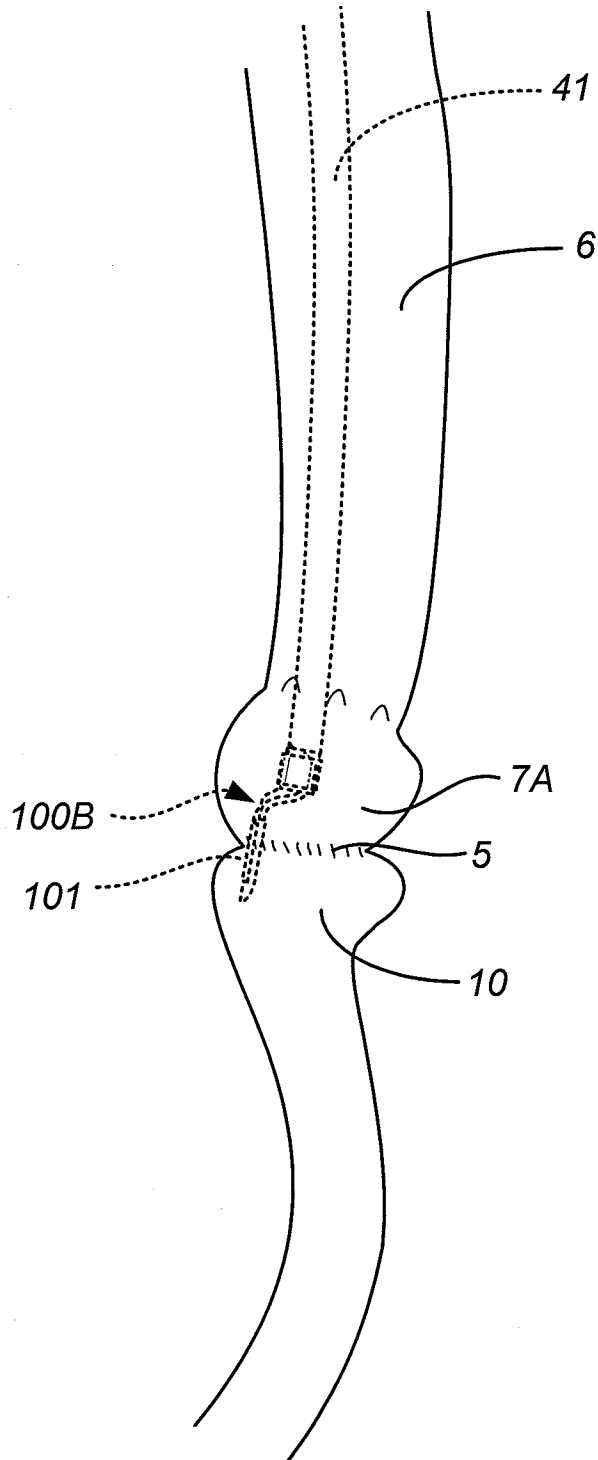

FIG. 1D

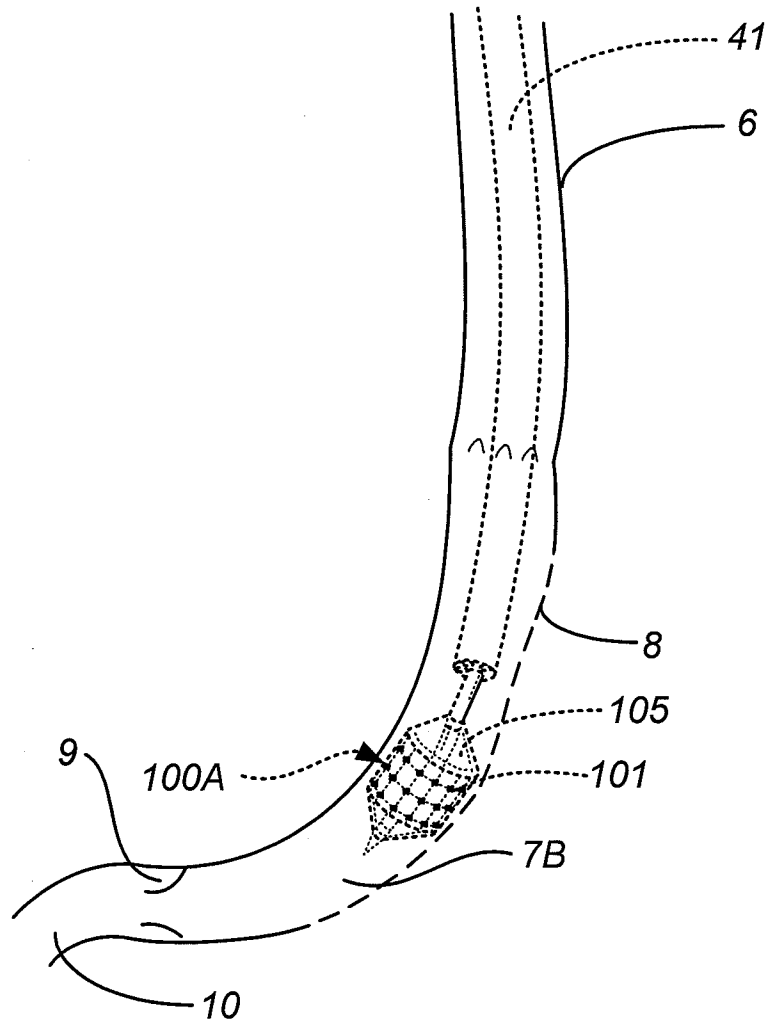

FIG. 2A

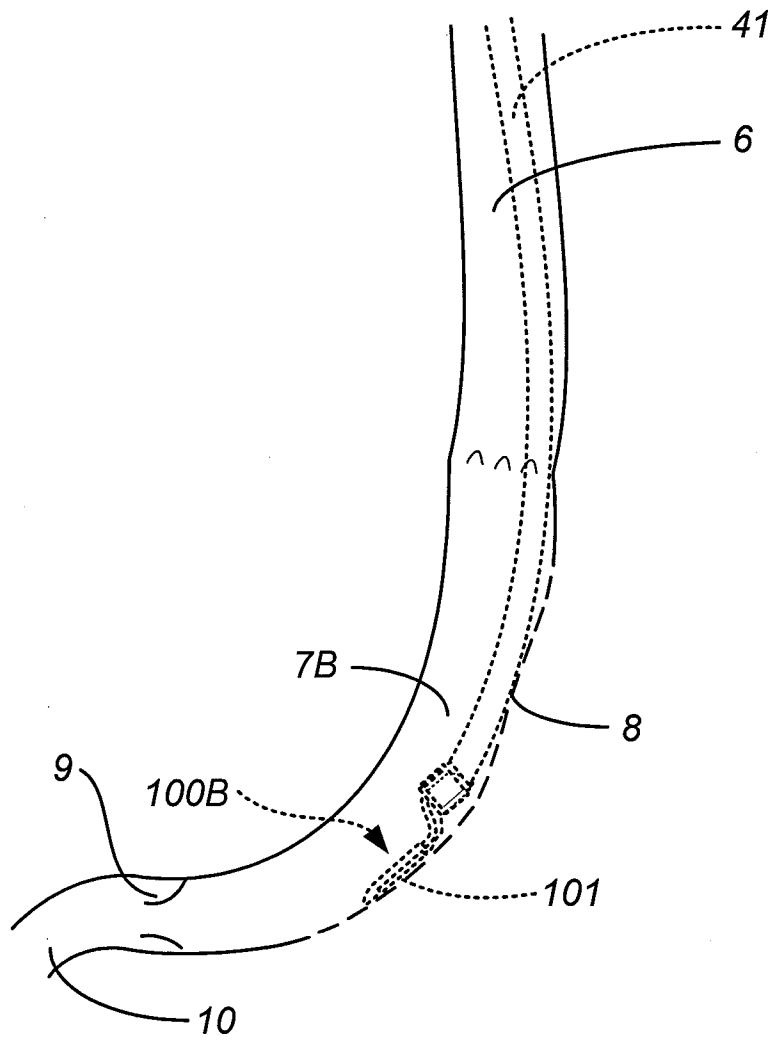

FIG. 2B

Overview of Method

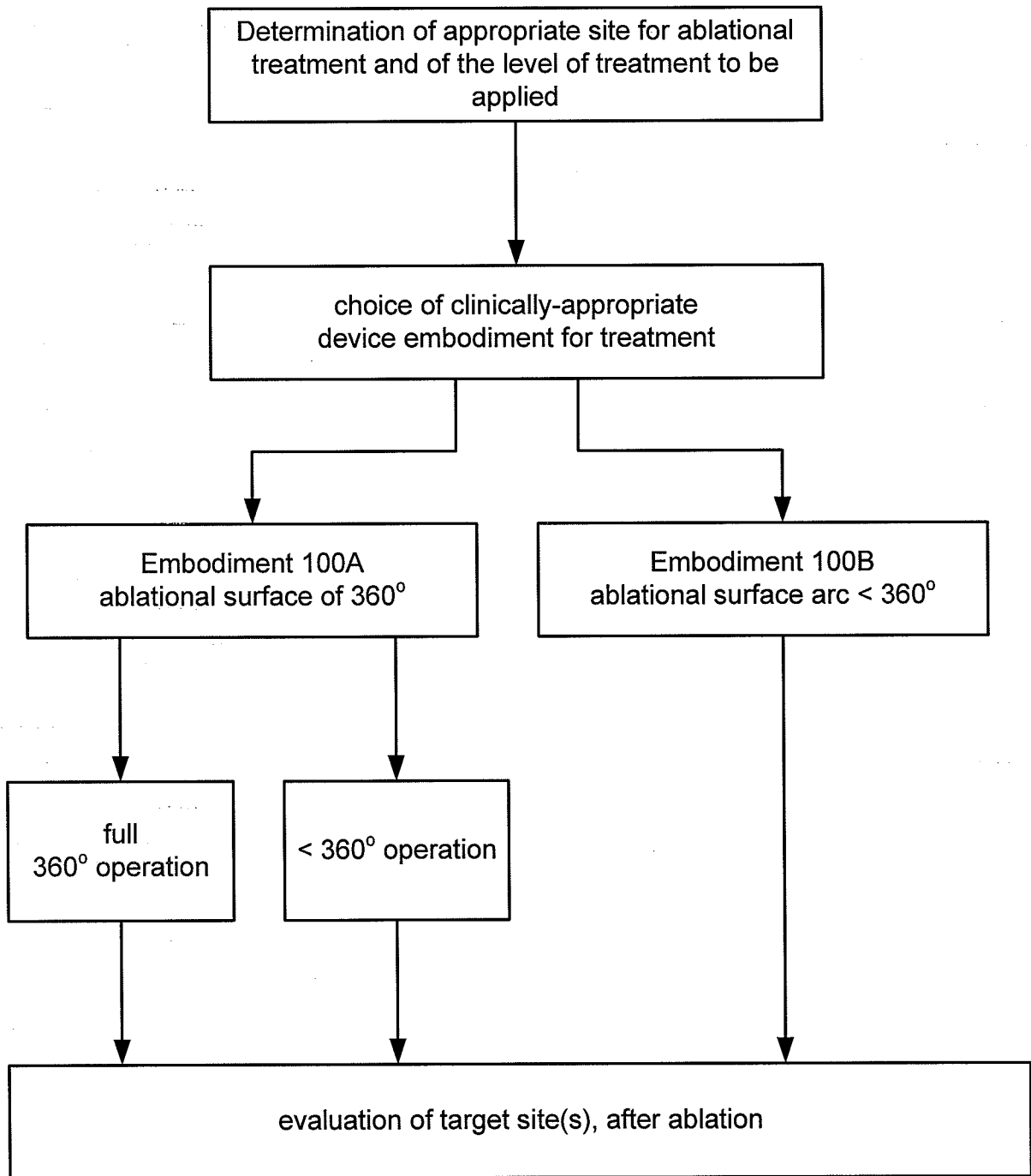

FIG. 3

Operational Steps of the Method

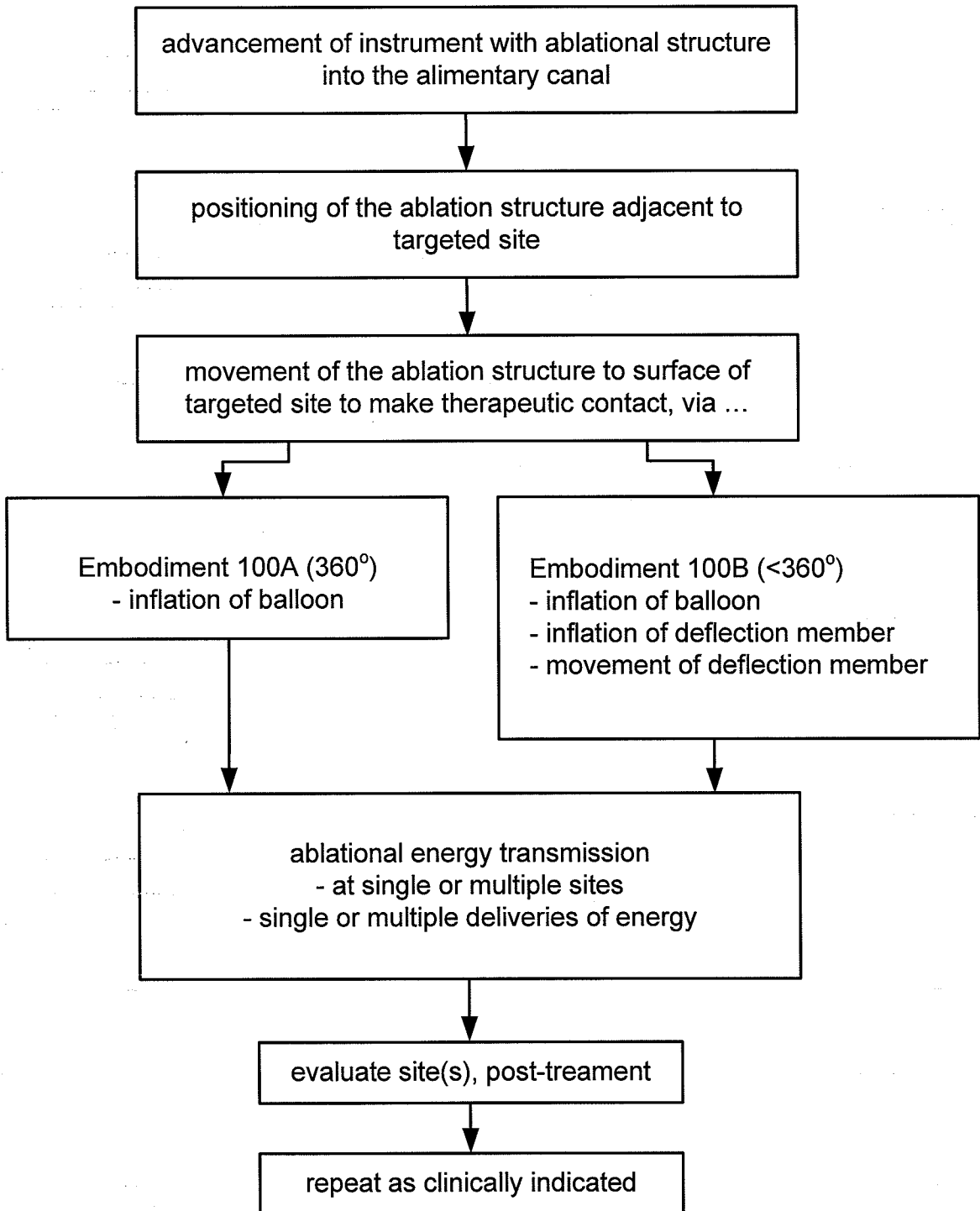

FIG. 4

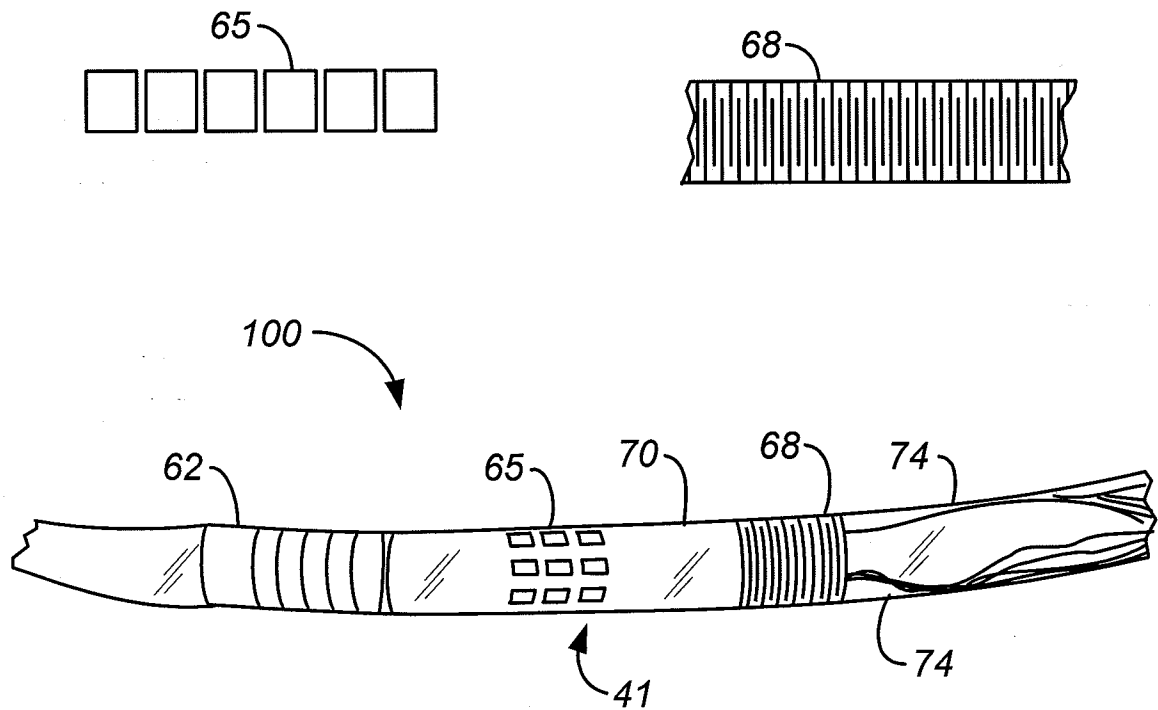

FIG. 5

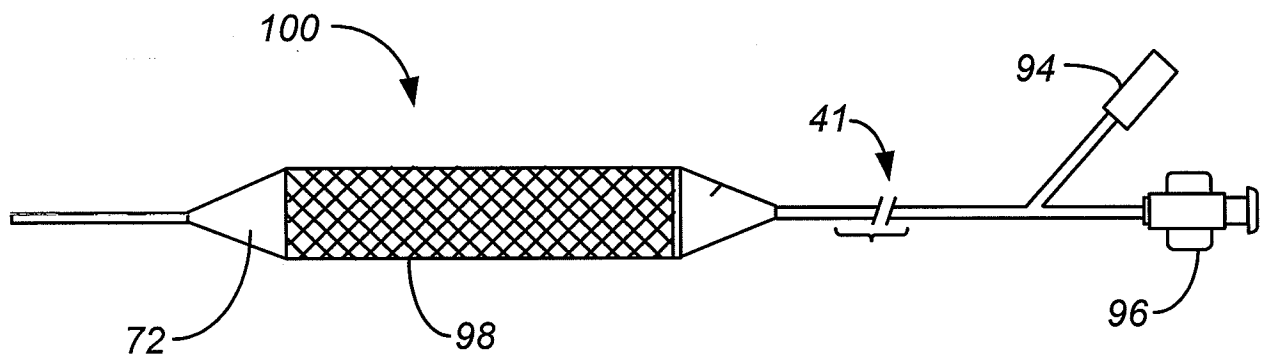

FIG. 6

10/39

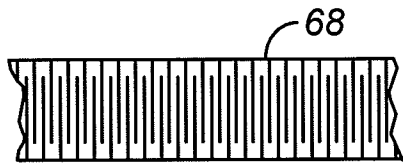

FIG. 7A

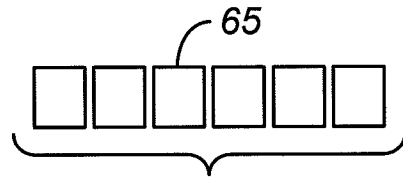

FIG. 7B

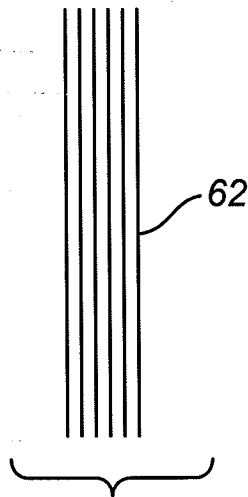

FIG. 7C

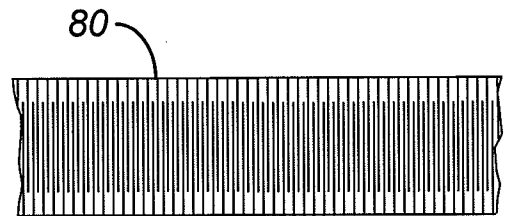

FIG. 8A

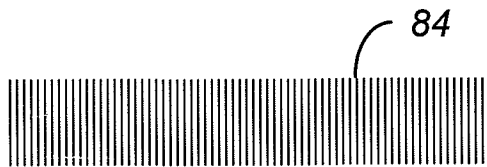

FIG. 8B

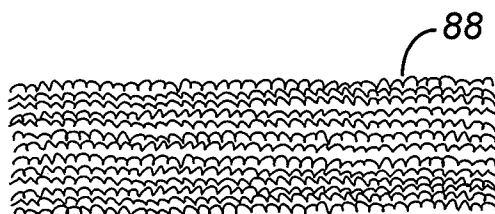

FIG. 8C

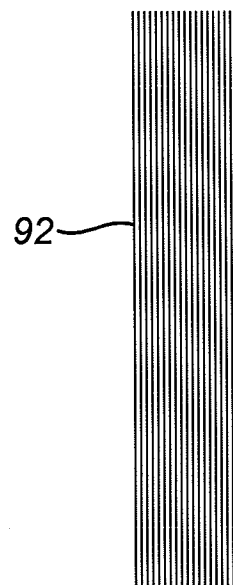

FIG. 8D

11/39

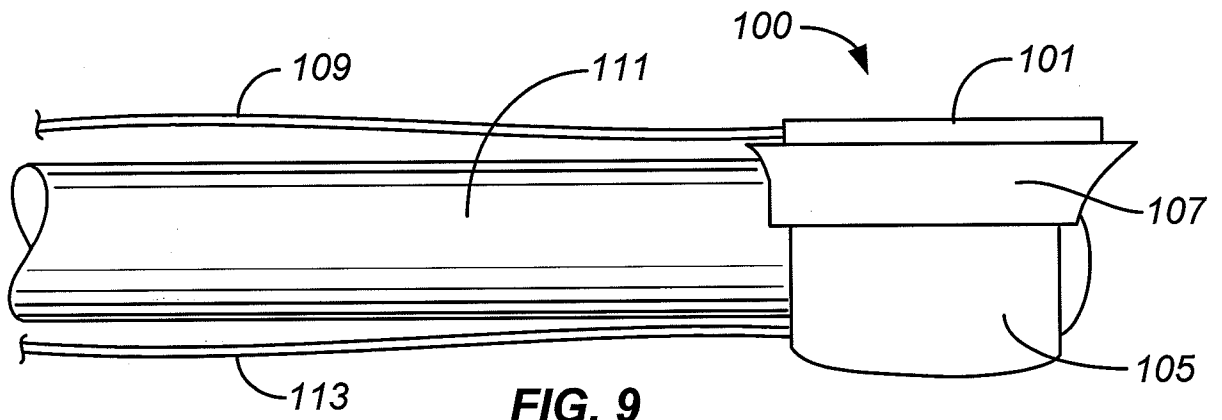

FIG. 9

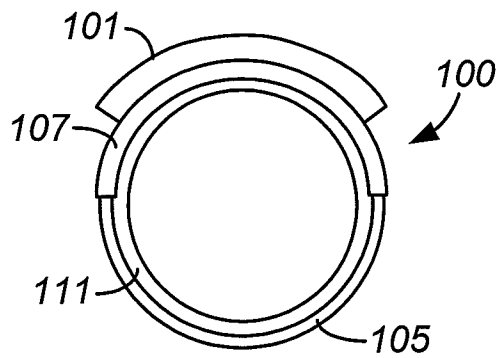

FIG. 10

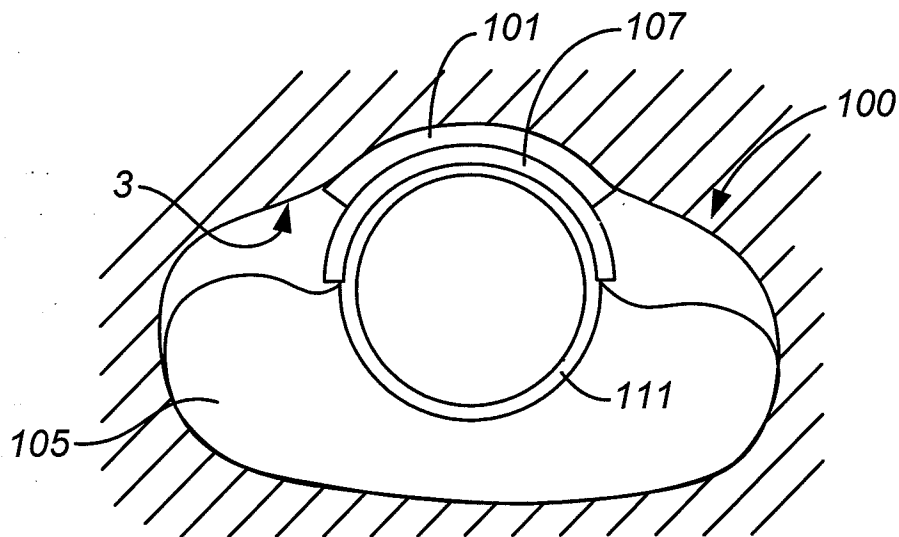

FIG. 11

12/39

FIG. 12

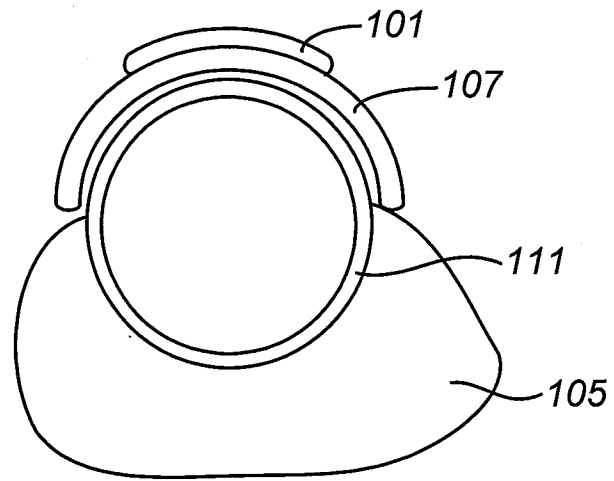

FIG. 13

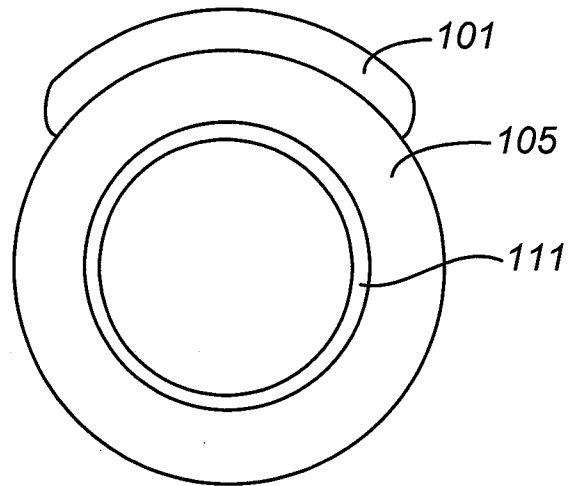
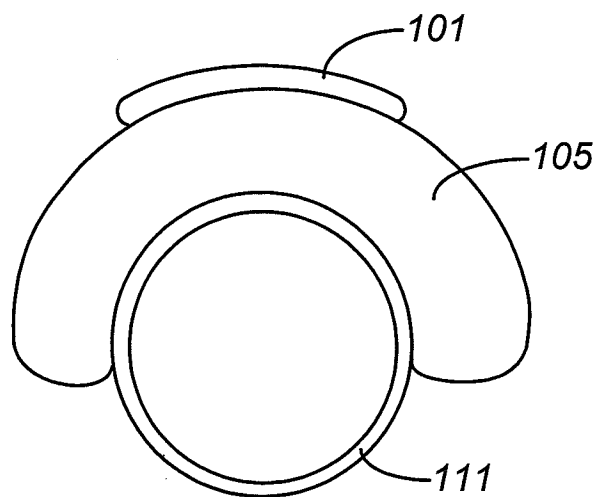

FIG. 14



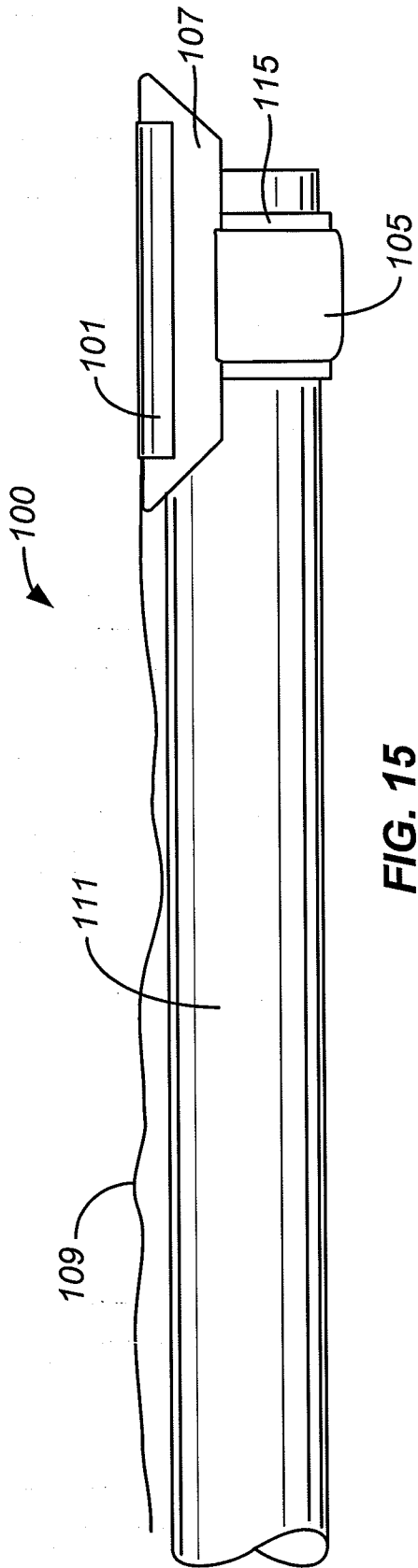

FIG. 15

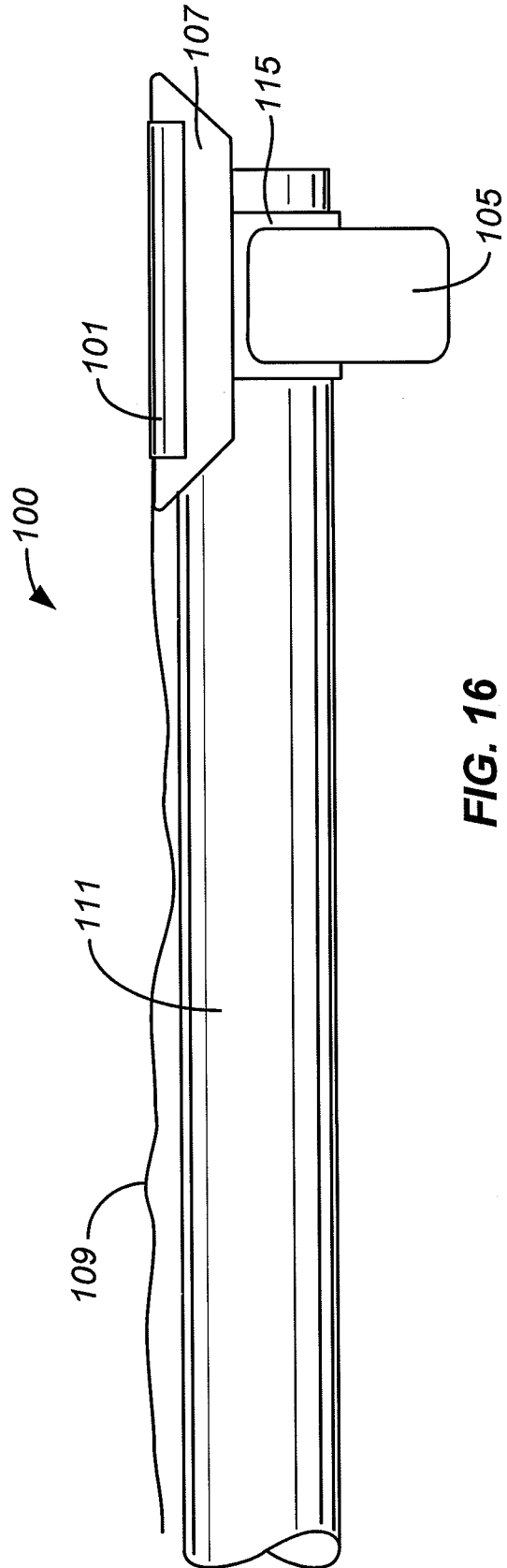

FIG. 16

14/39

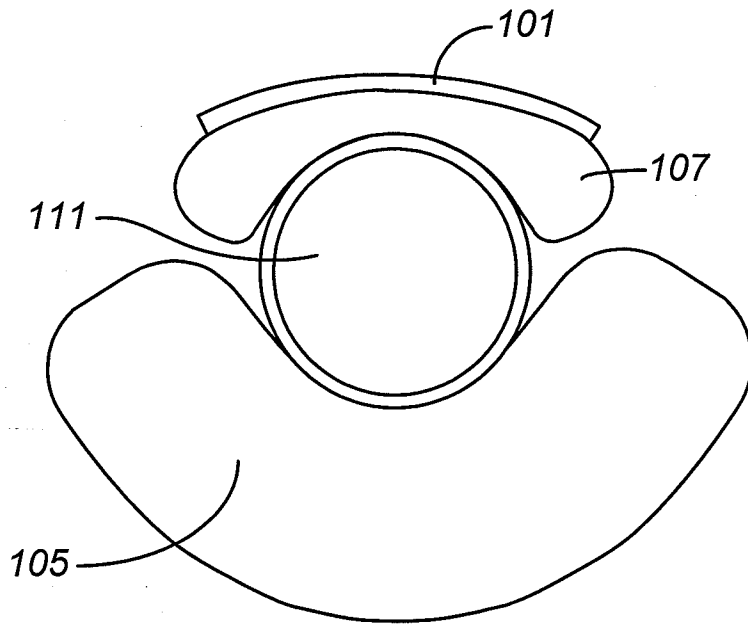

FIG. 17

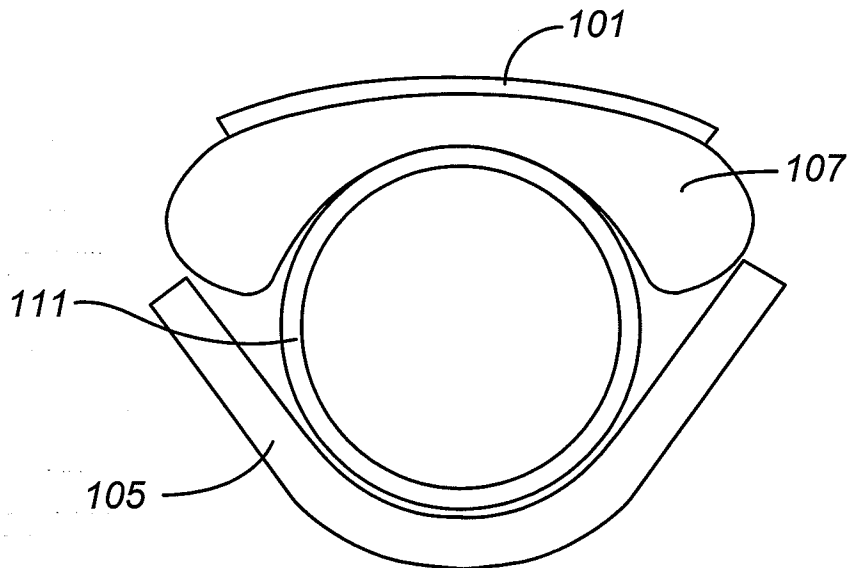

FIG. 18

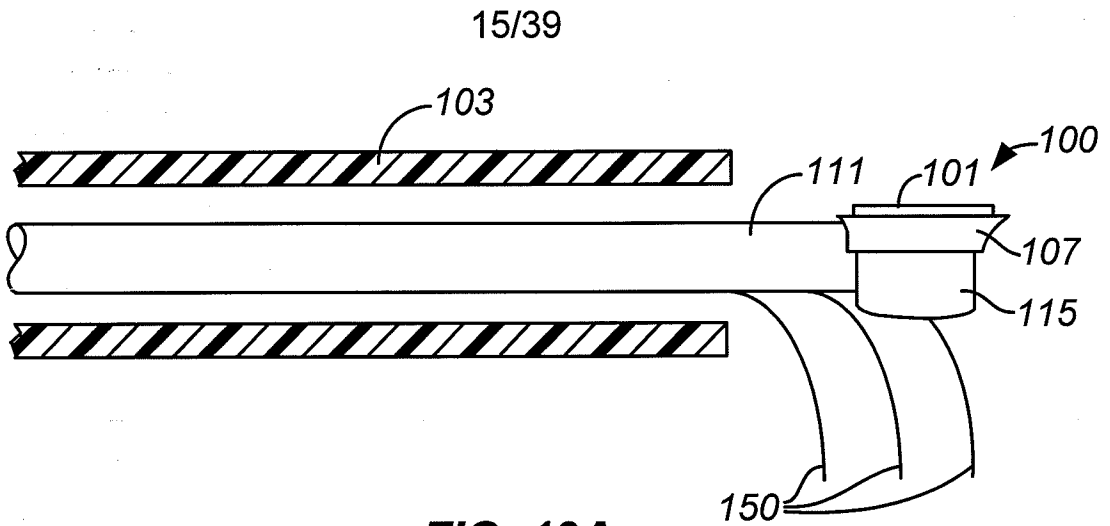

FIG. 19A

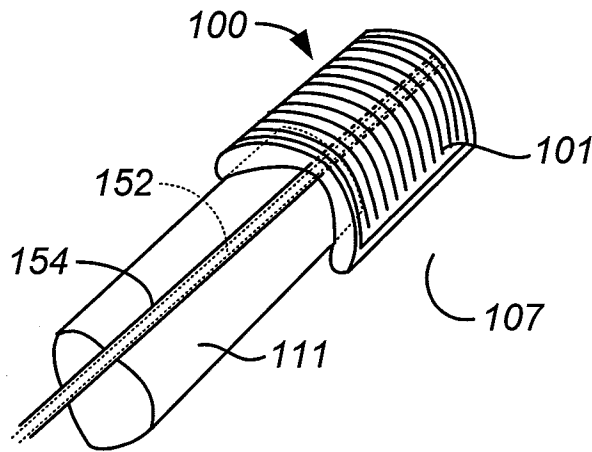

FIG. 19B

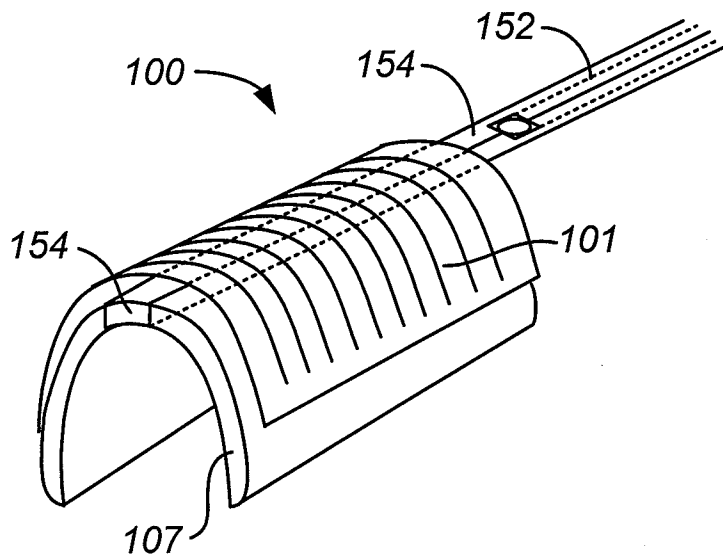

FIG. 20

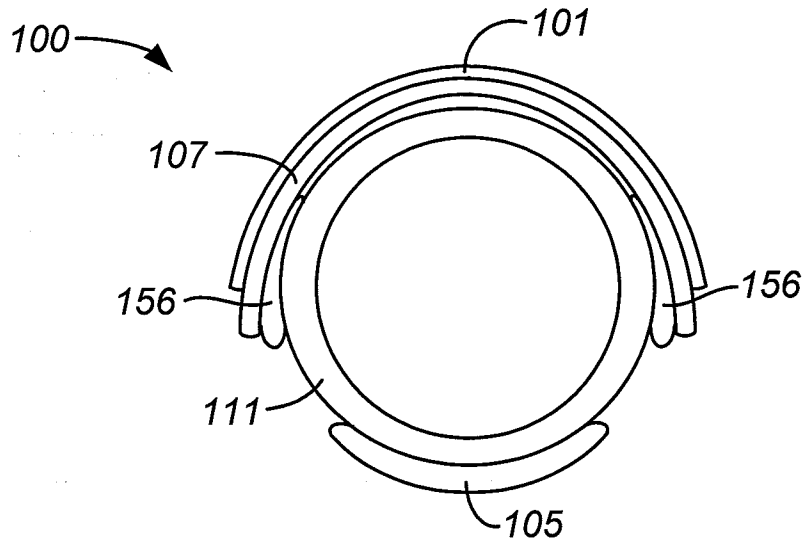

FIG. 21

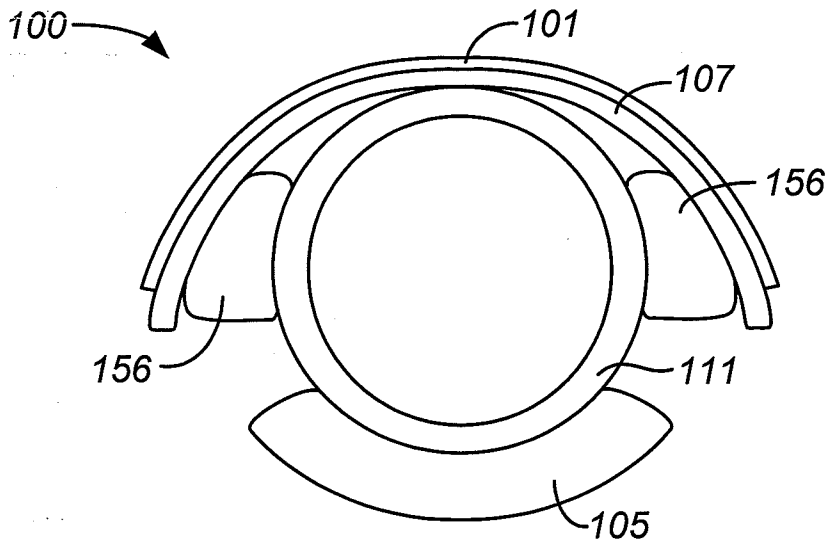

FIG. 22

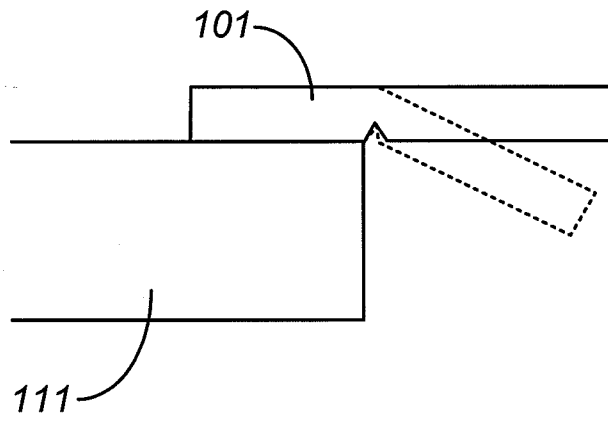

FIG. 23

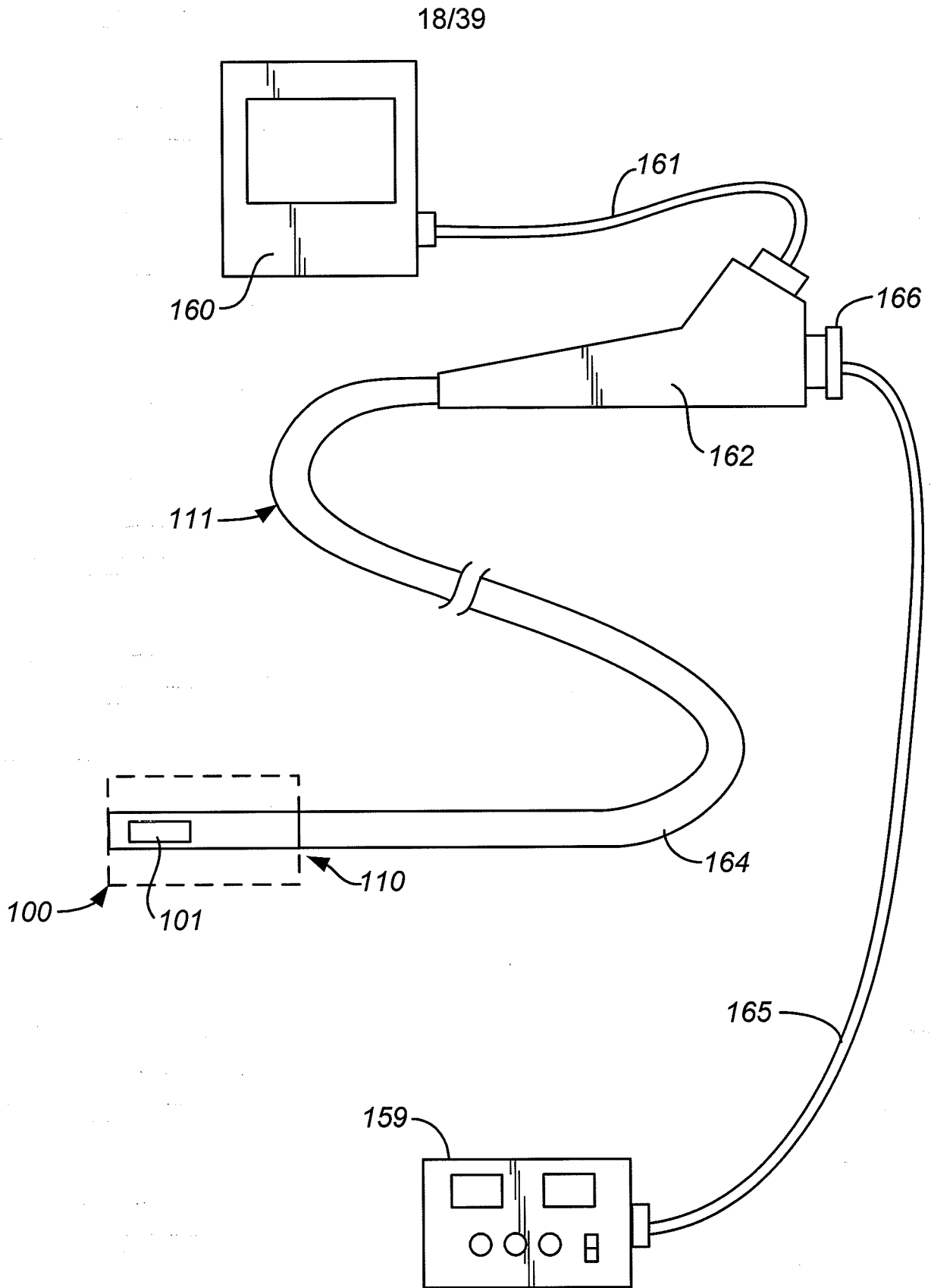

FIG. 24

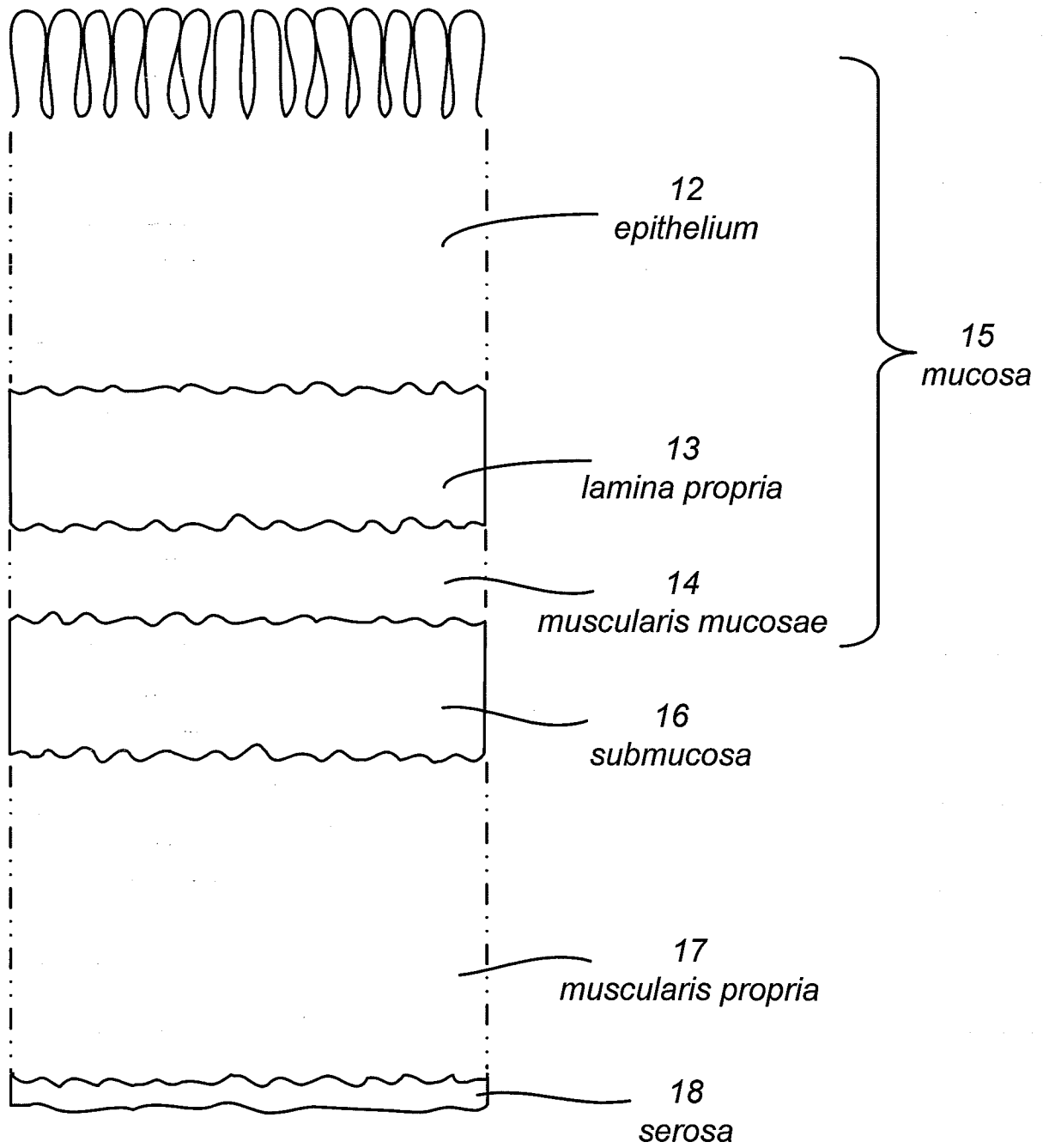

FIG. 25

20/39

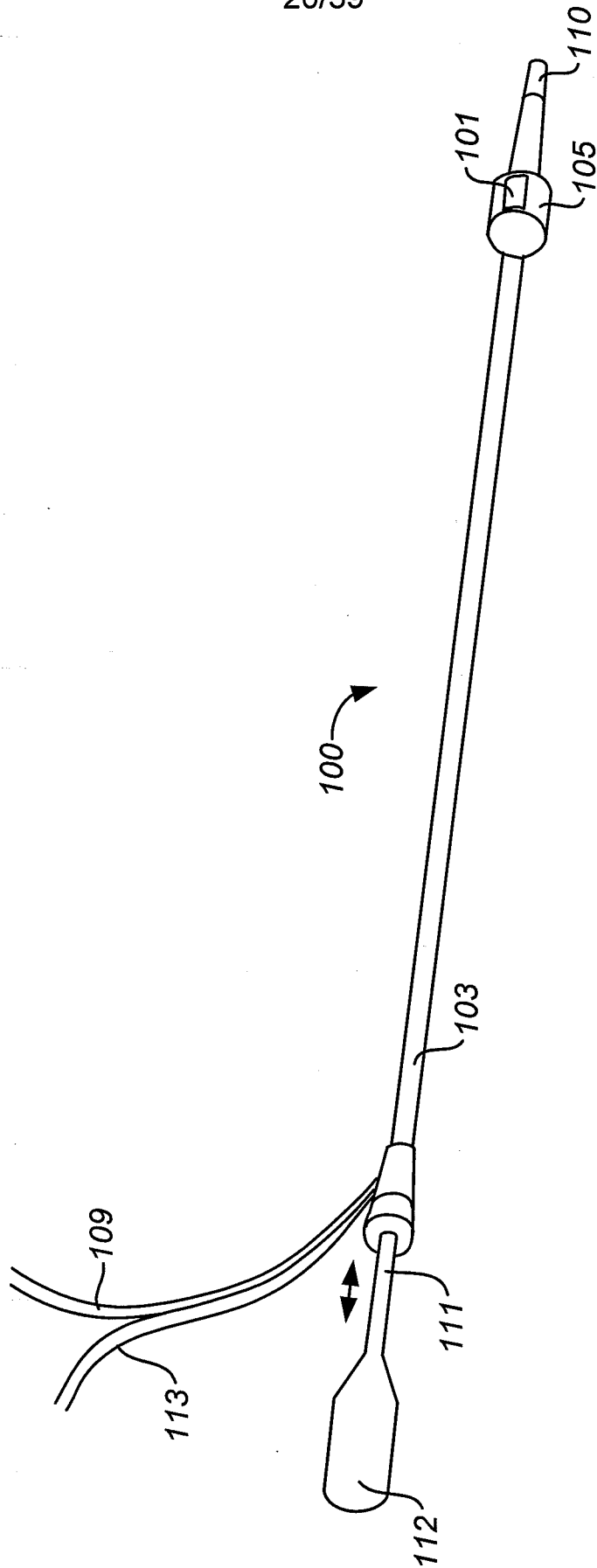

FIG. 26

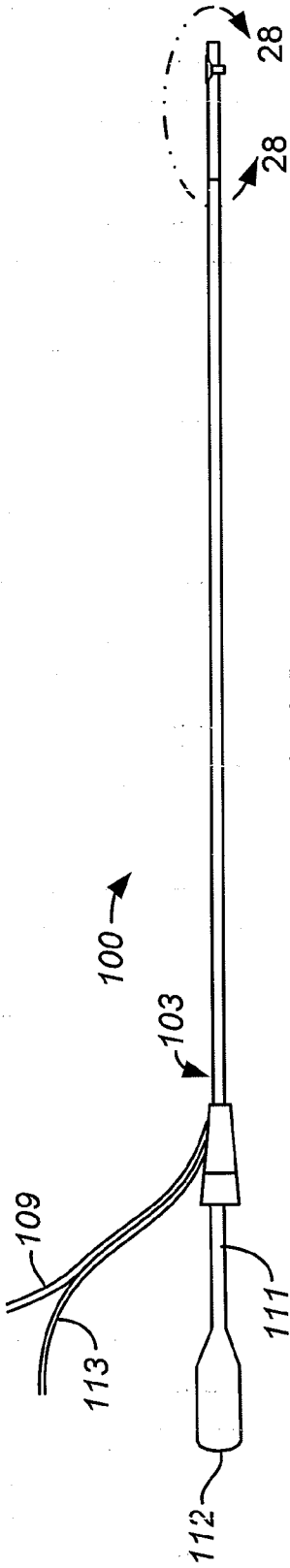

FIG. 27

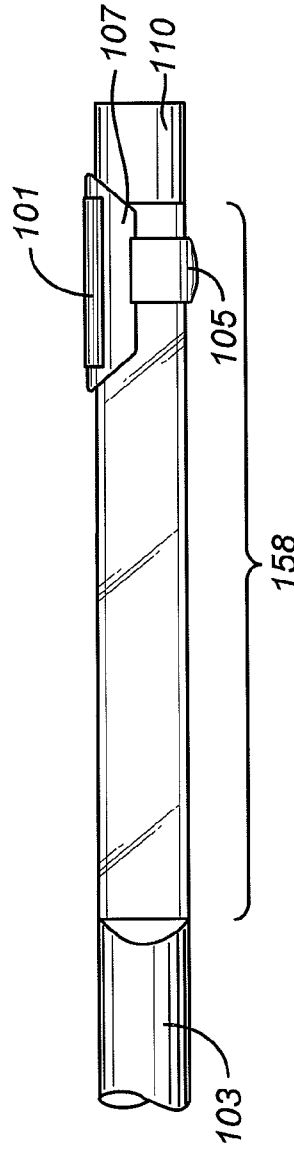

FIG. 28

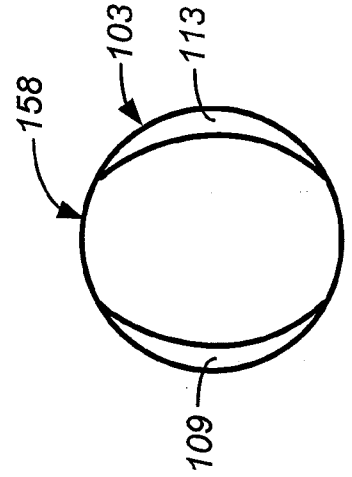

FIG. 29

22/39

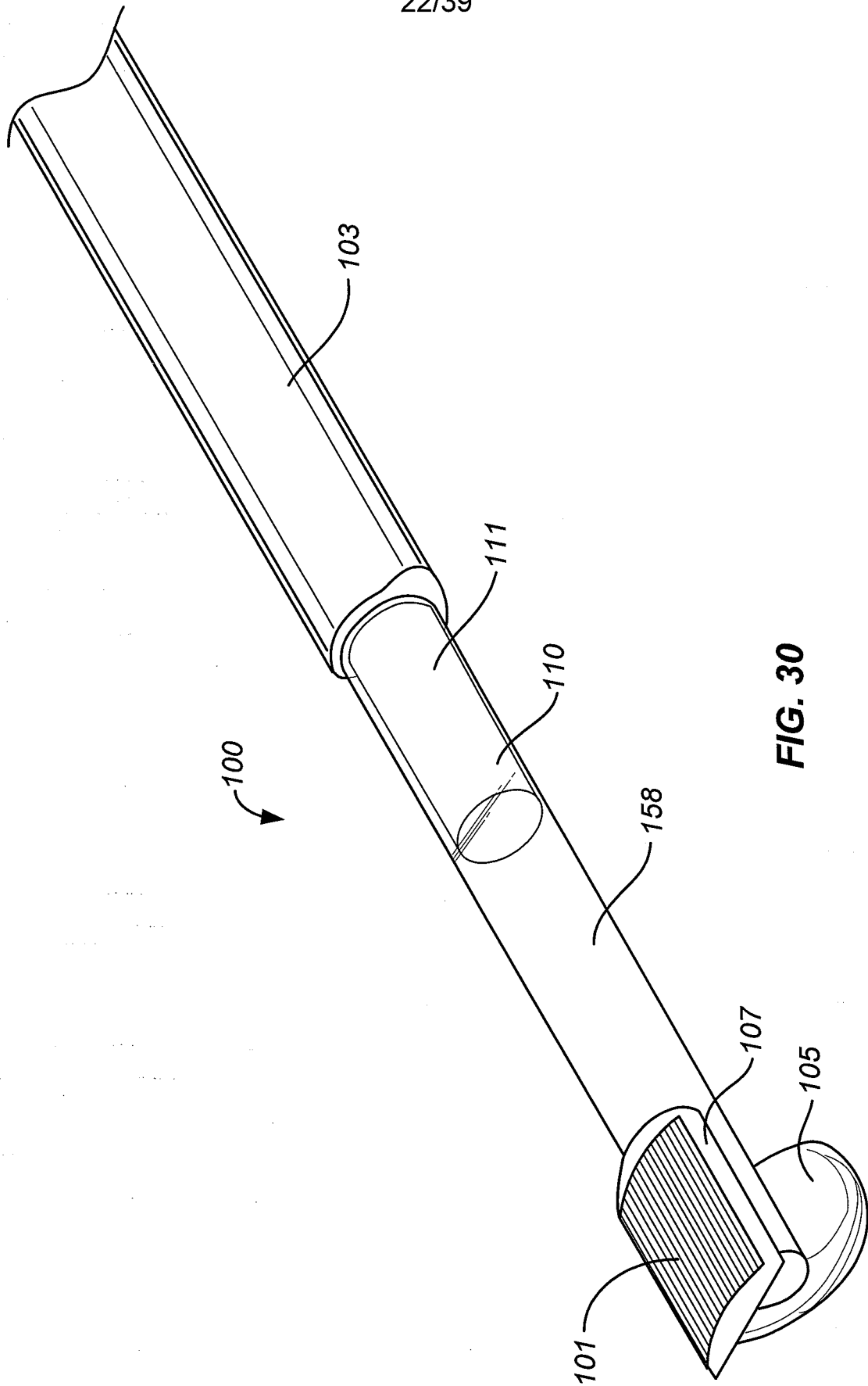

FIG. 30

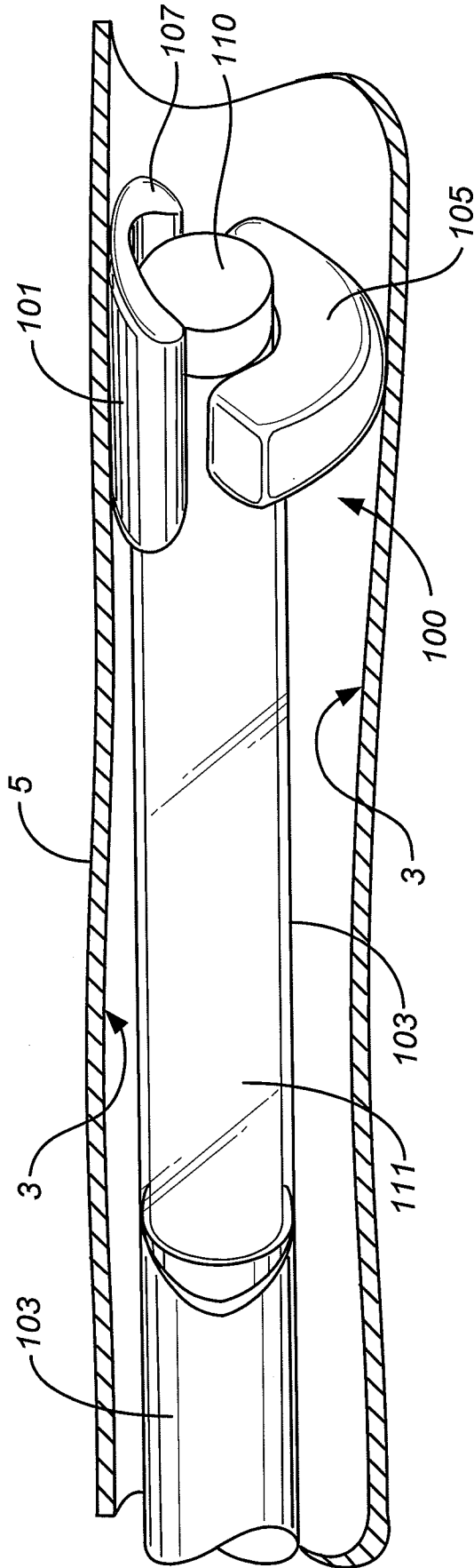

FIG. 31

24/39

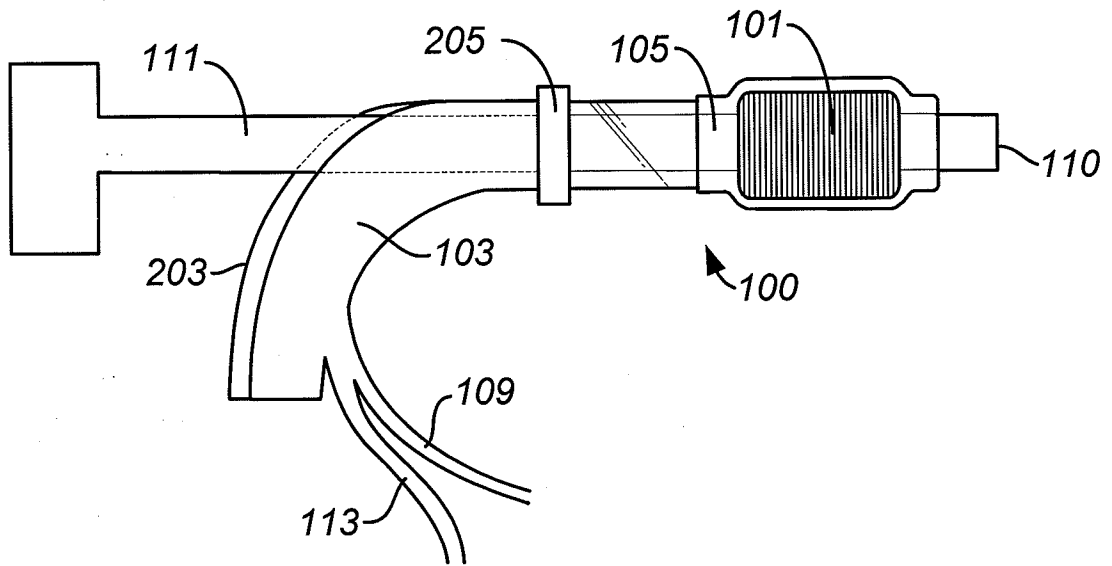

FIG. 32

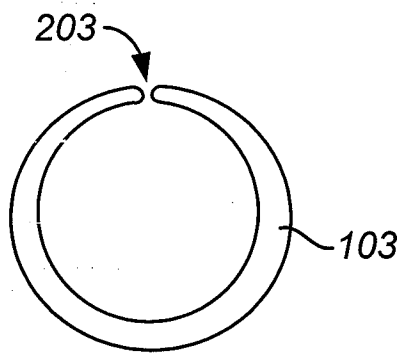

FIG. 33A

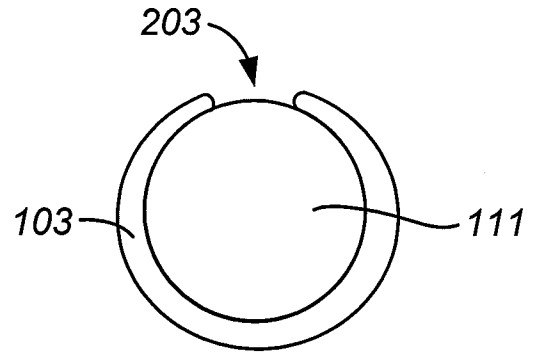

FIG. 33B

25/39

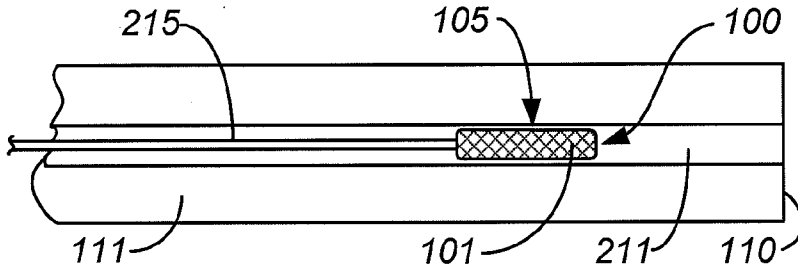

FIG. 34A

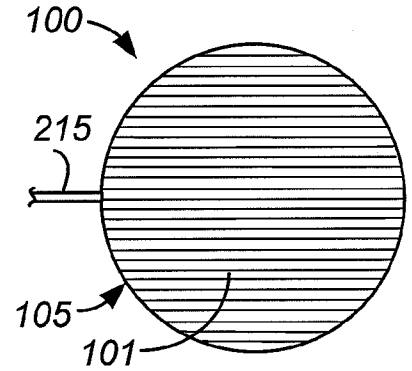

FIG. 34B

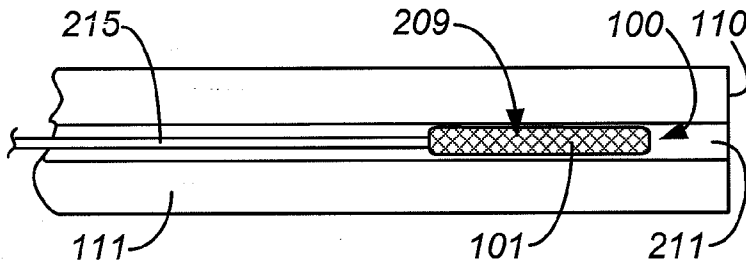

FIG. 35A

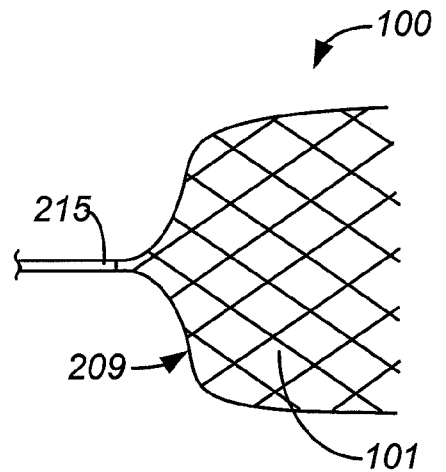

FIG. 35B

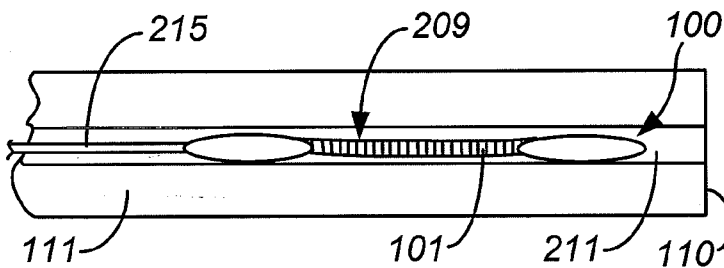

FIG. 36A

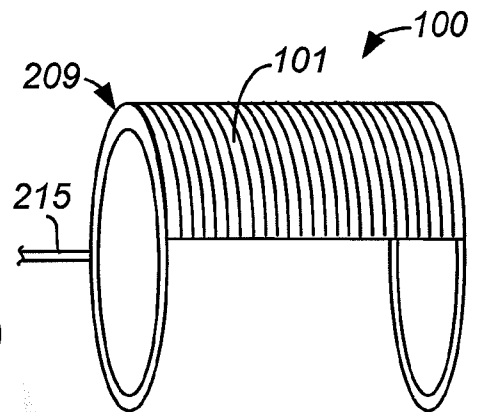

FIG. 36B

26/39

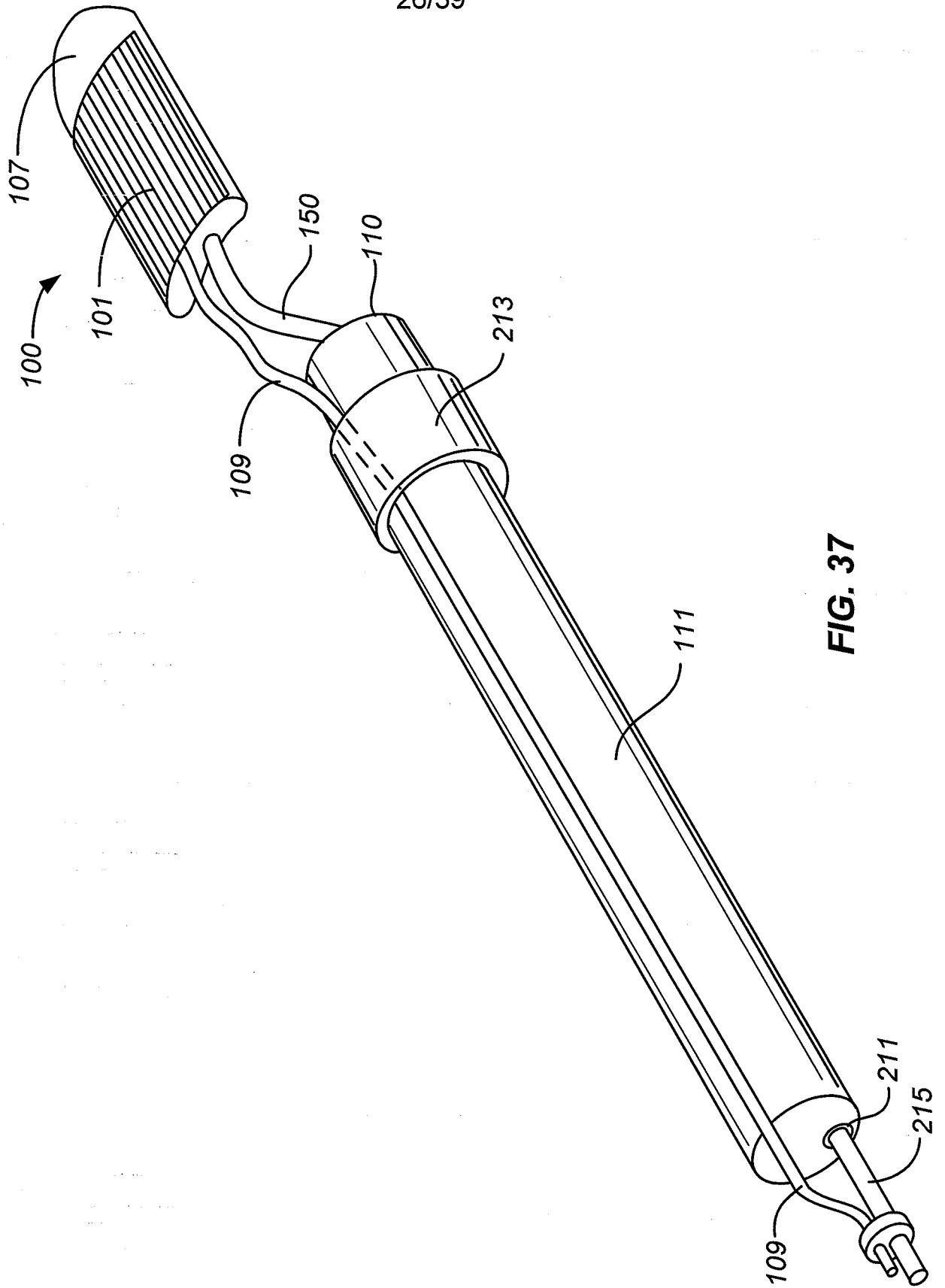

FIG. 37

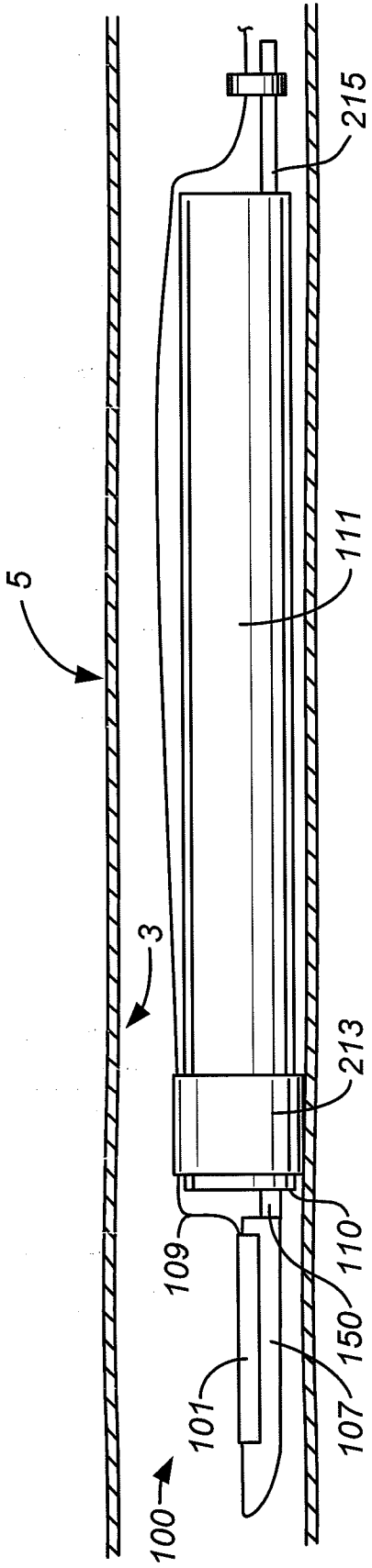

FIG. 38

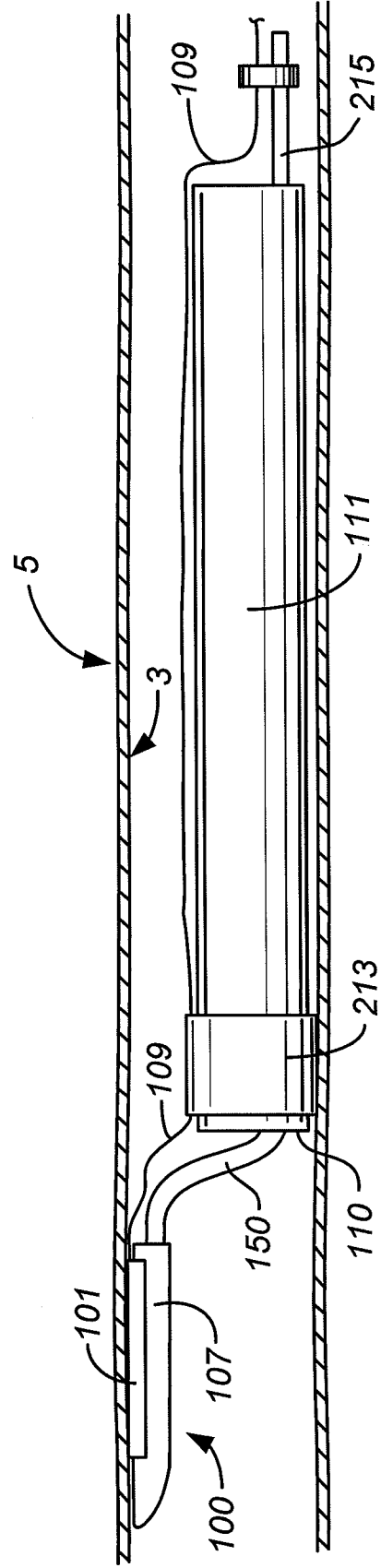

FIG. 39

28/39

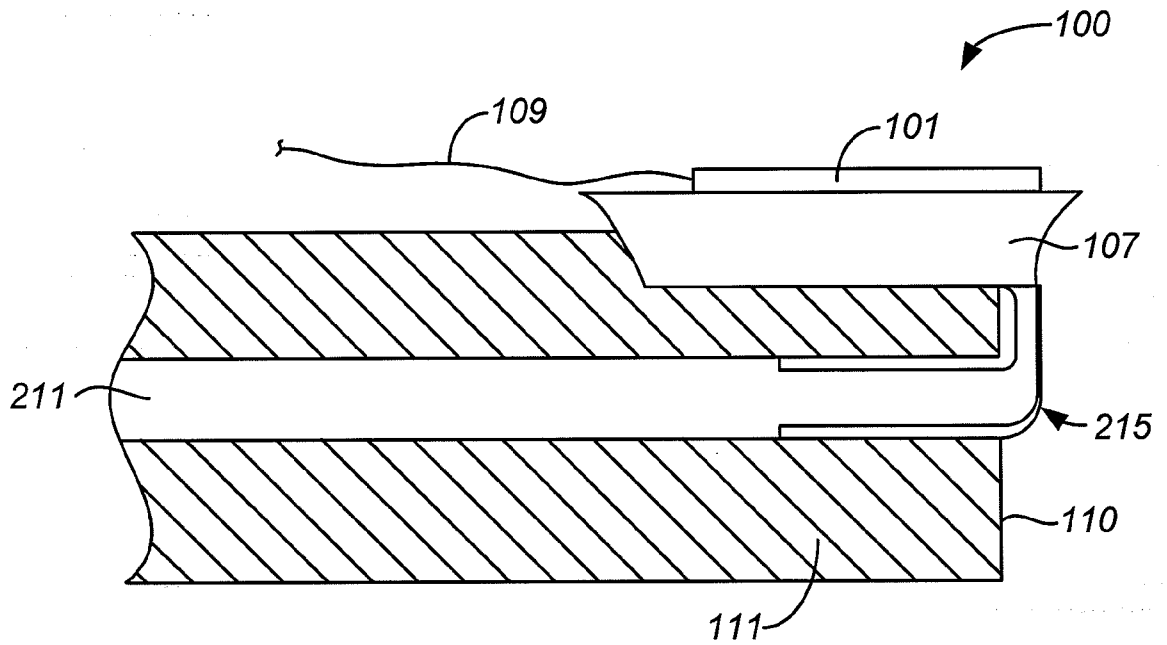

FIG. 40

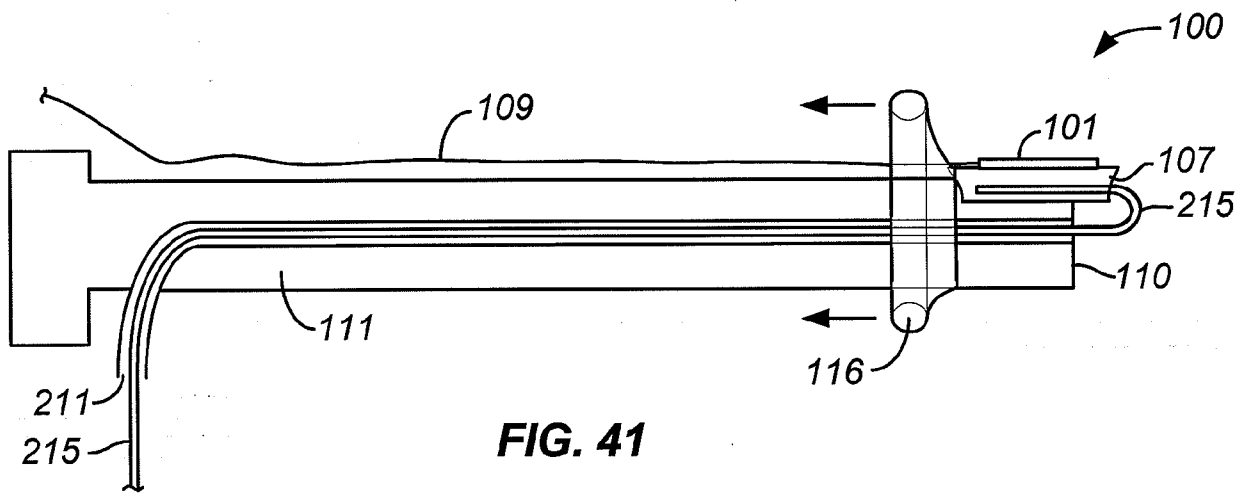

FIG. 41

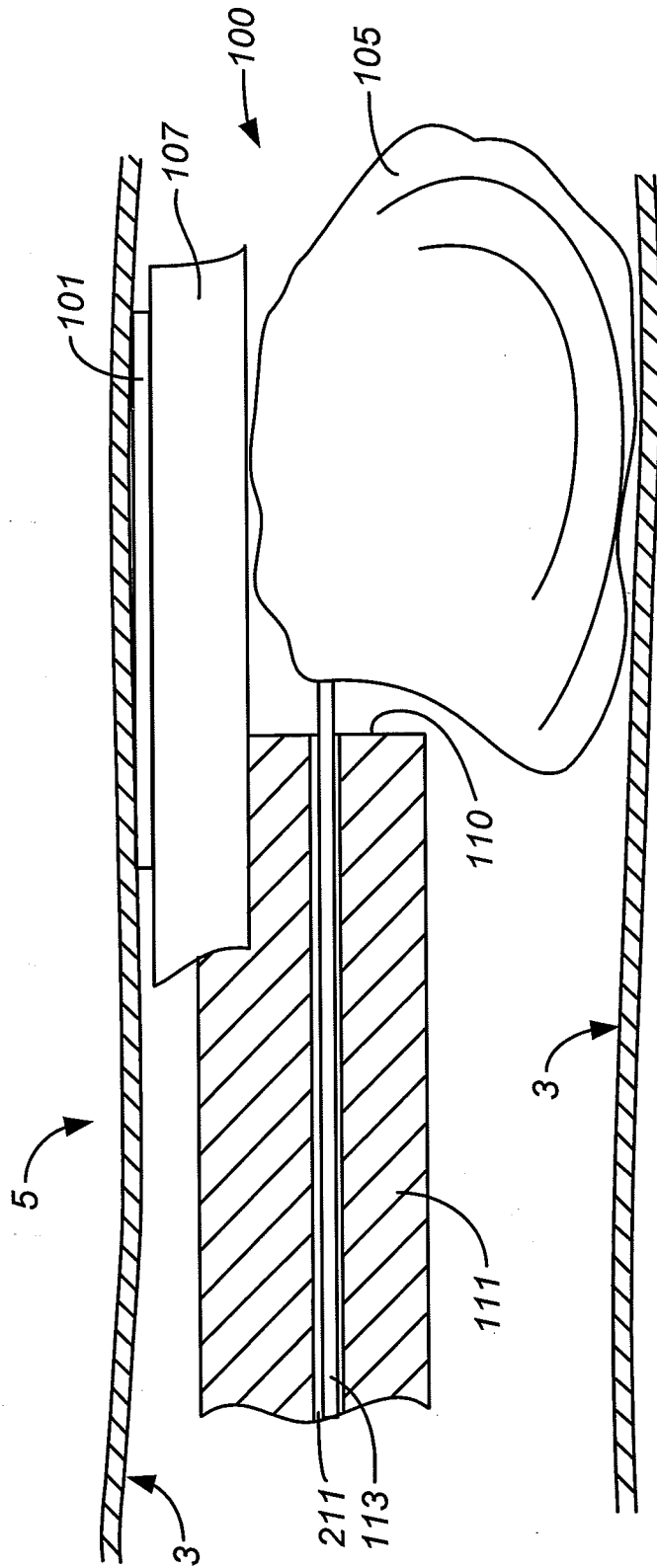

FIG. 42

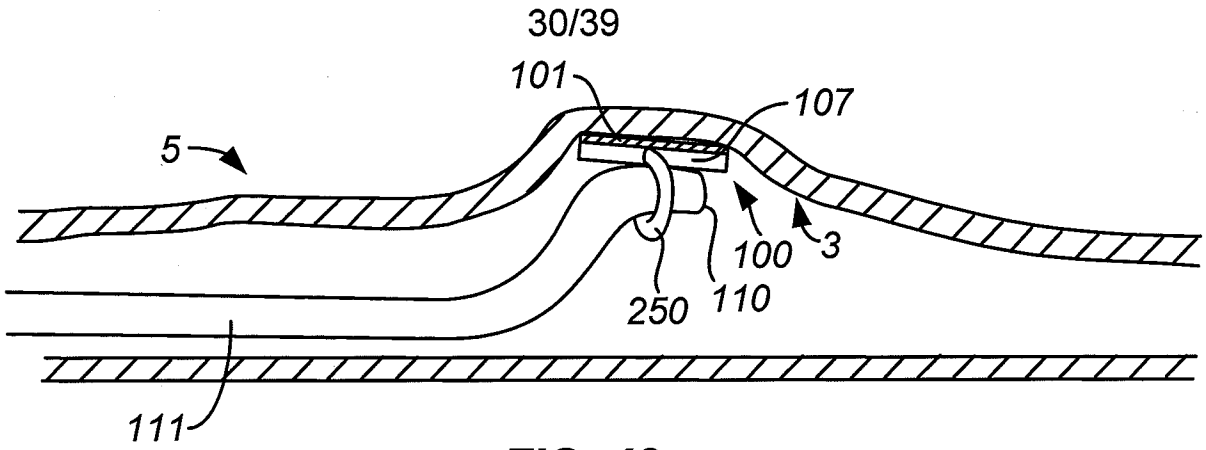

FIG. 43

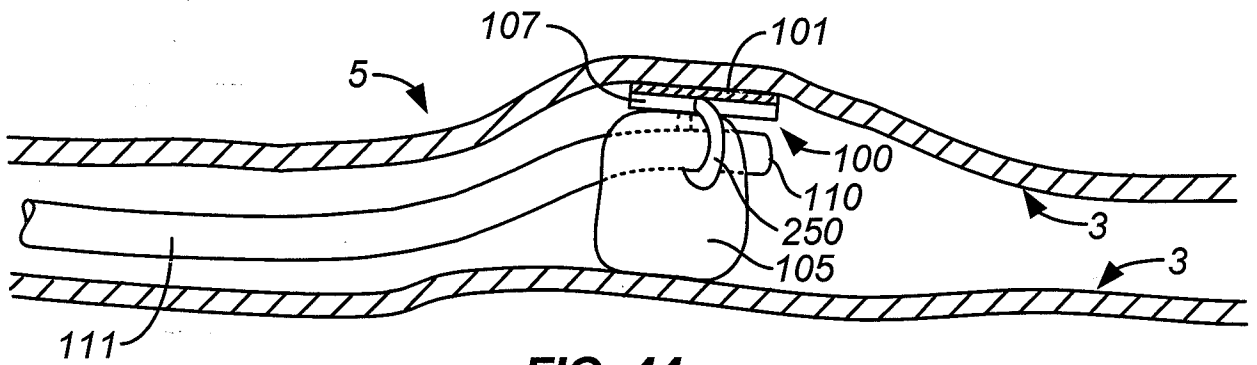

FIG. 44

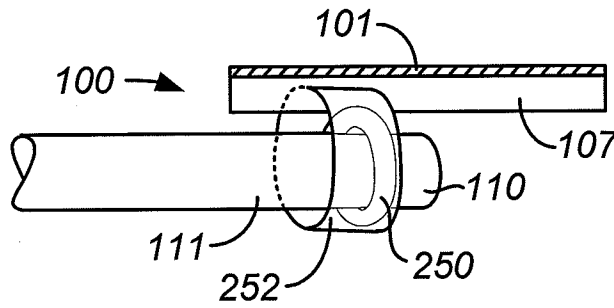

FIG. 45A

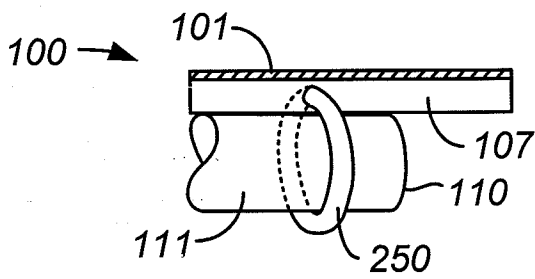

FIG. 45B

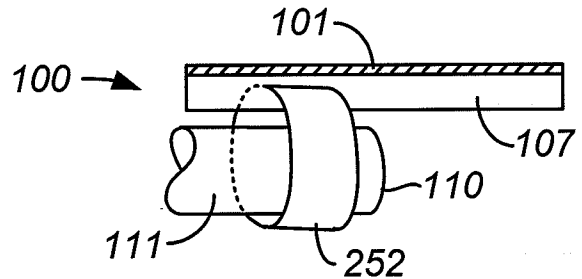

FIG. 45C

31/39

FIG. 46A

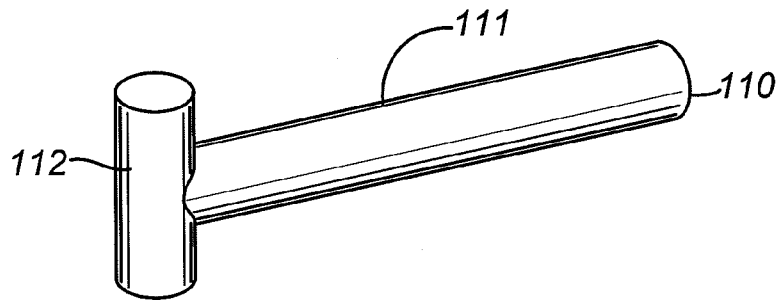

FIG. 46B

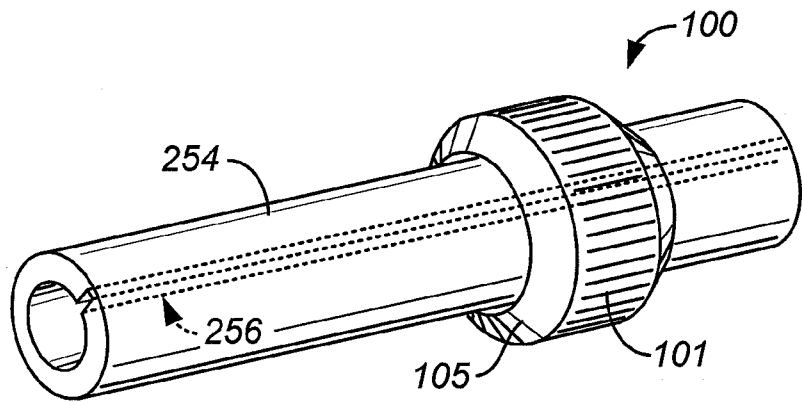

FIG. 46C

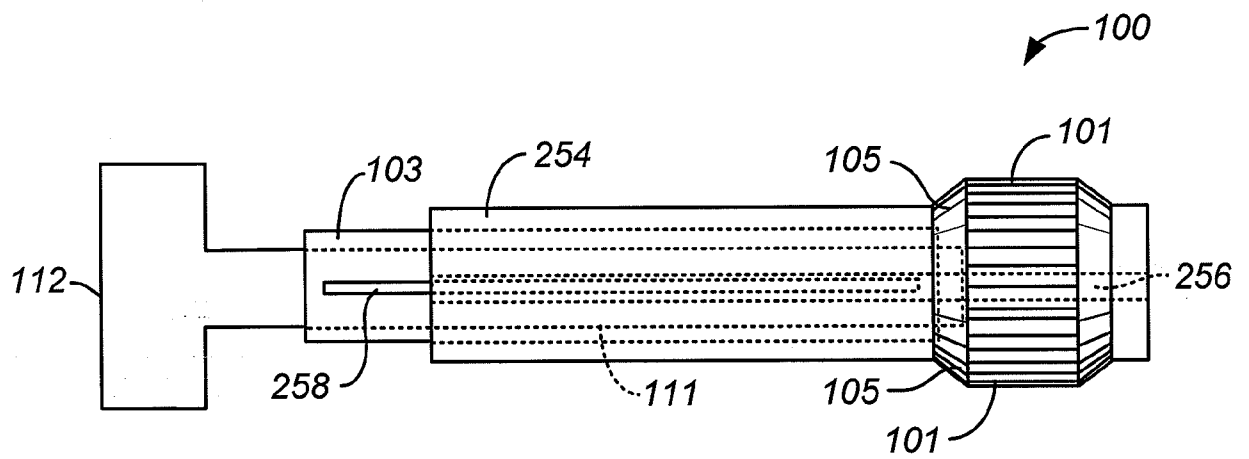
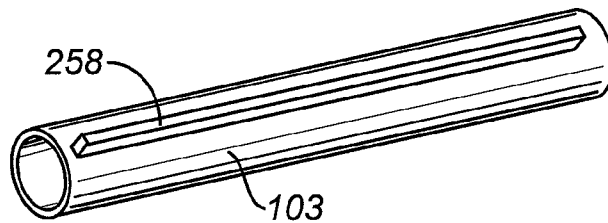

FIG. 47

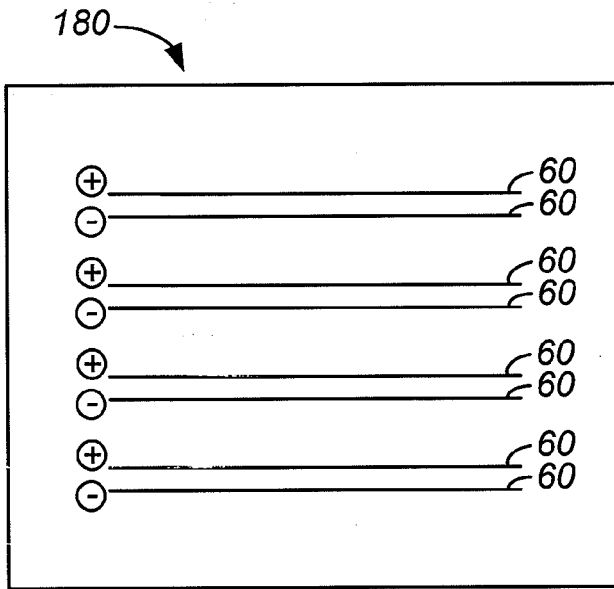

FIG. 48A

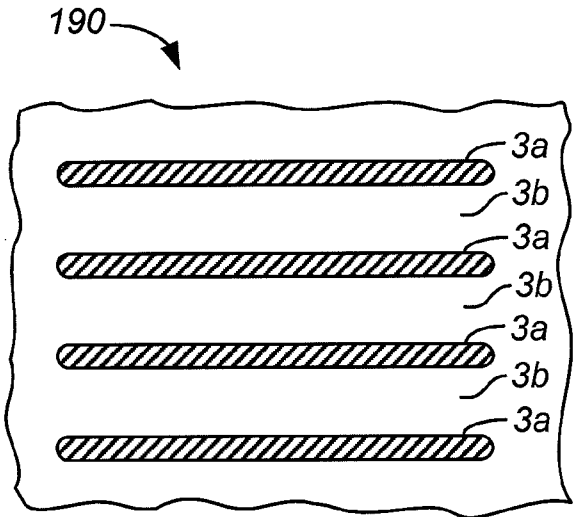

FIG. 48B

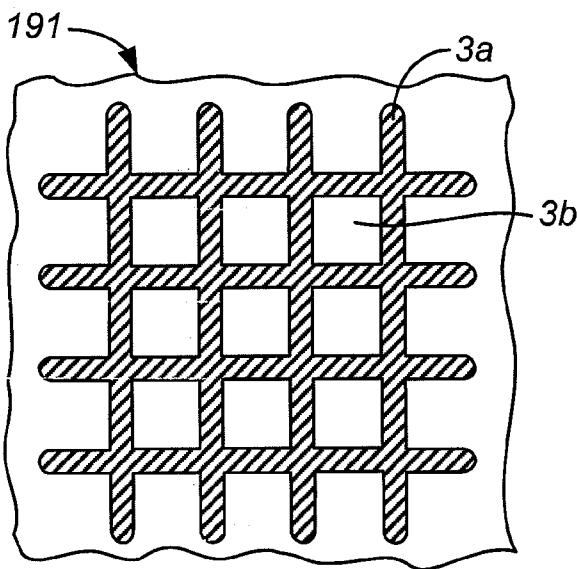

FIG. 48C

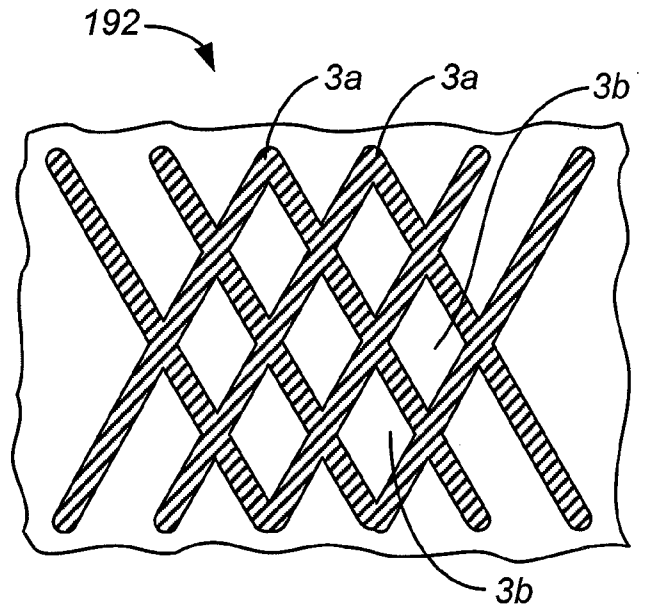

FIG. 48D

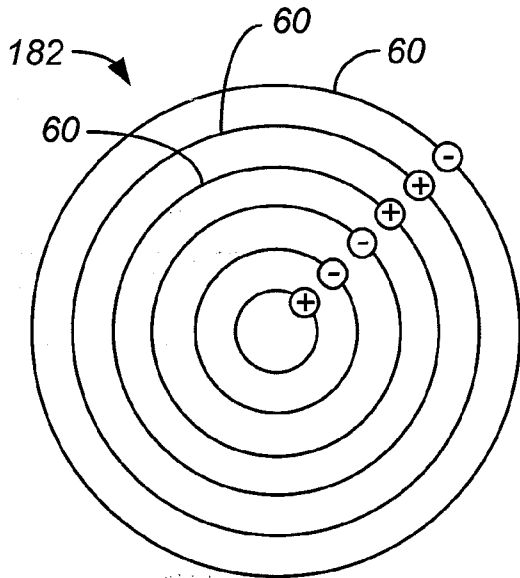

FIG. 49A

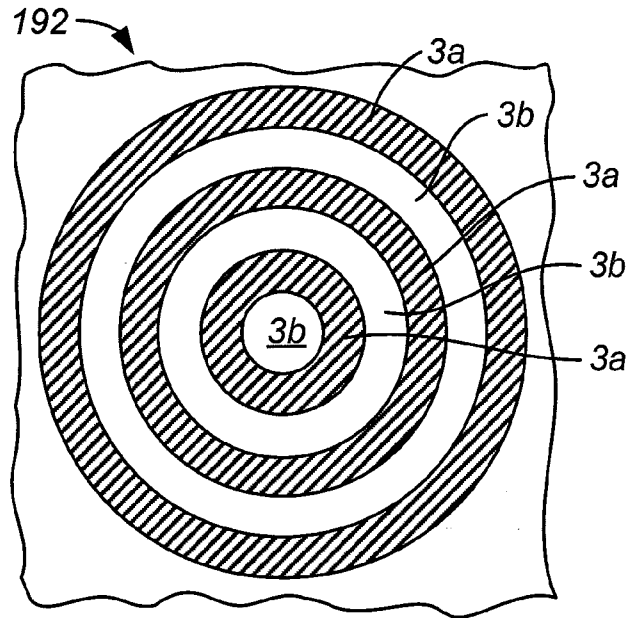

FIG. 49B

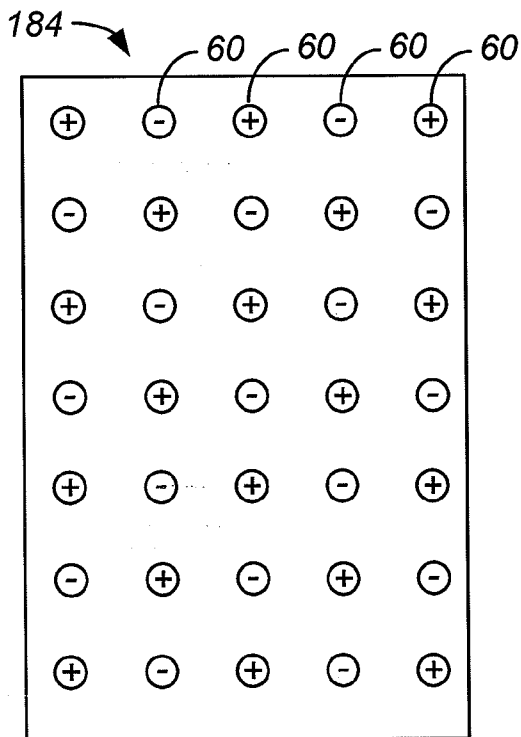

FIG. 50A

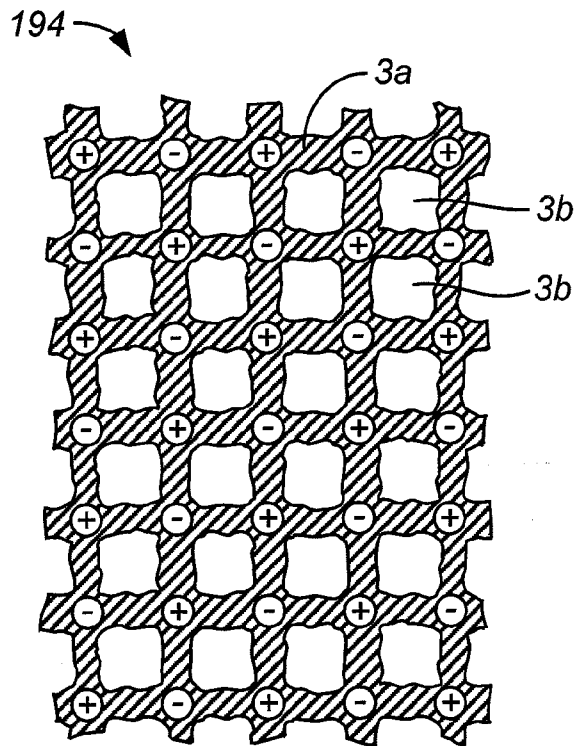

FIG. 50B

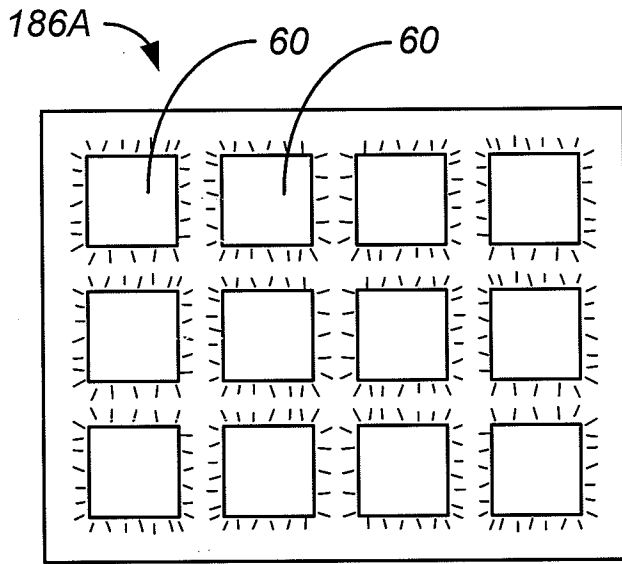

FIG. 51A

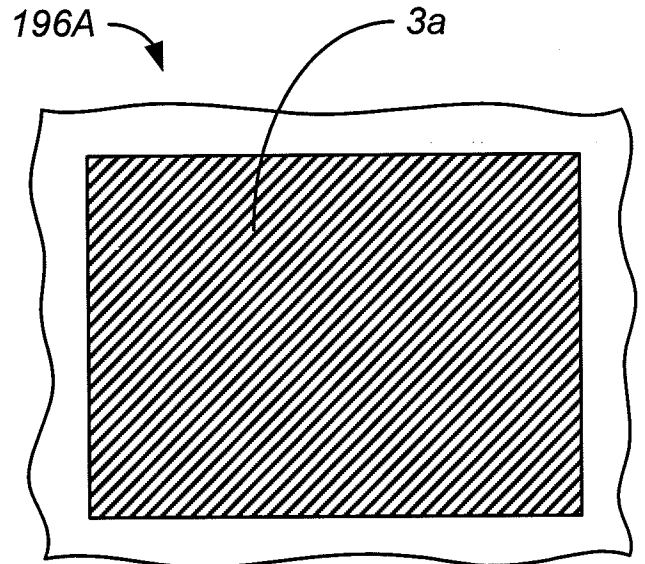

FIG. 51B

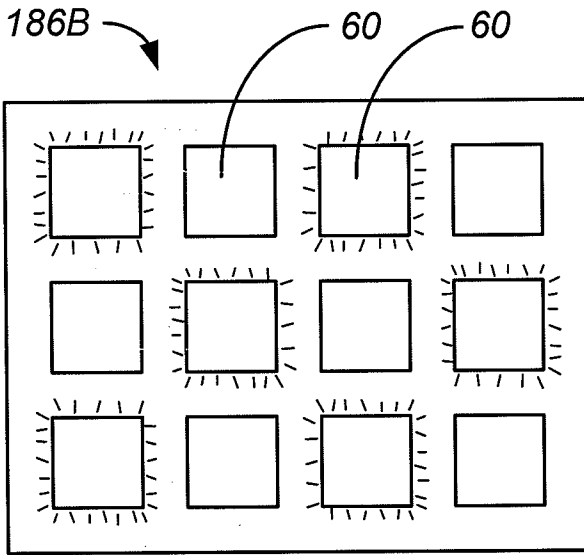

FIG. 52A

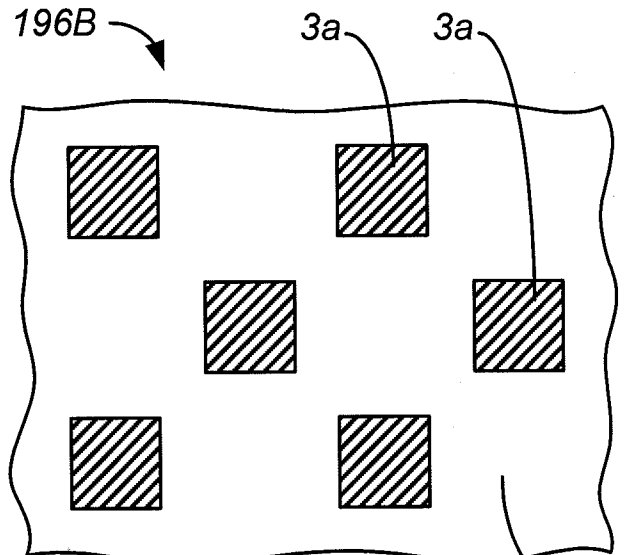

FIG. 52B

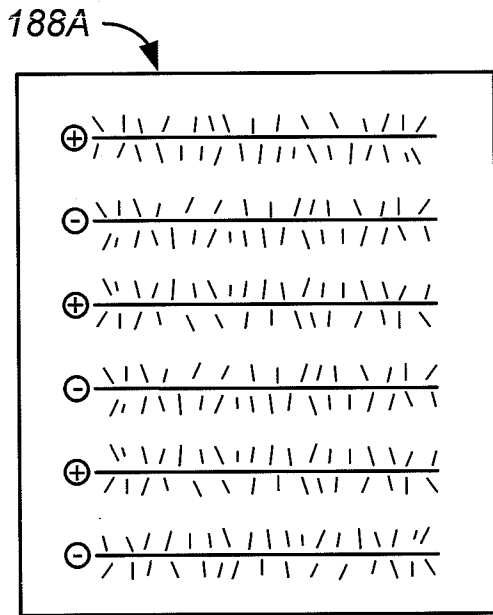

FIG. 53A

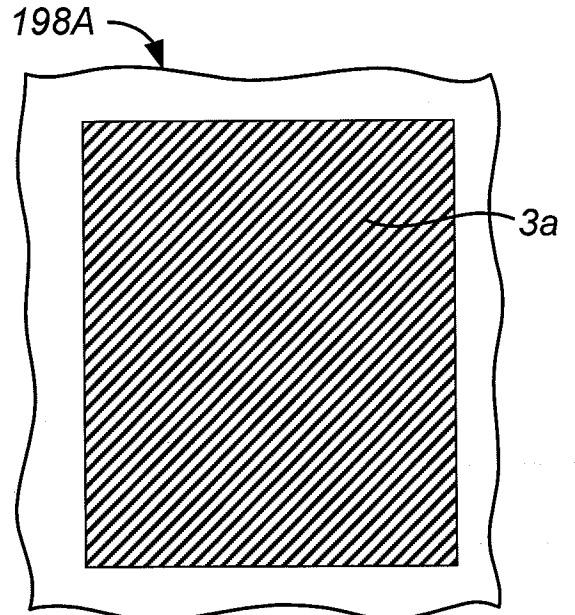

FIG. 53B

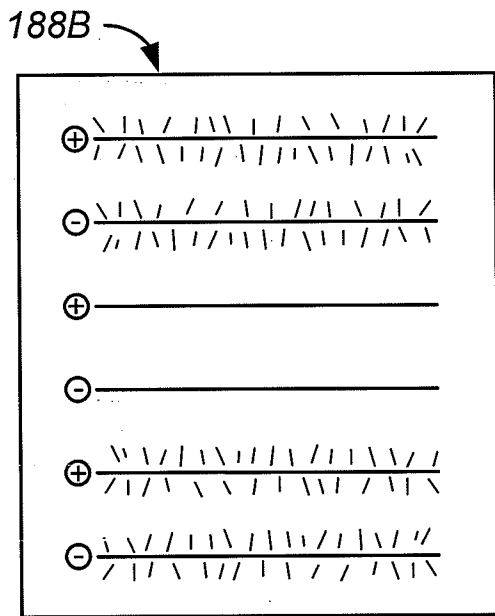

FIG. 54A

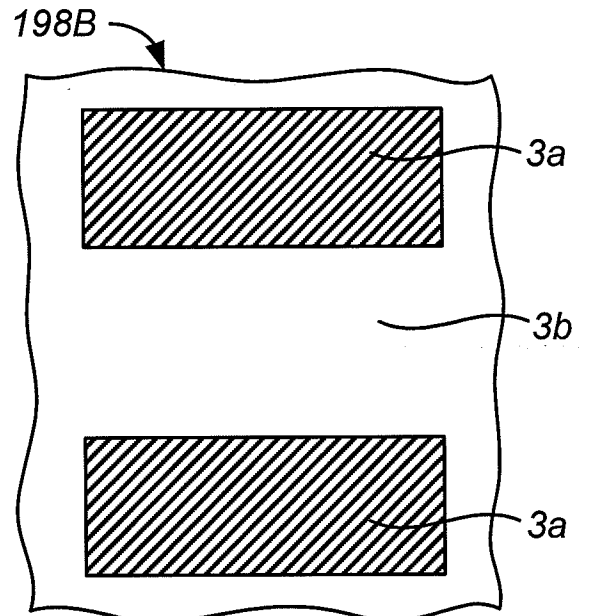

FIG. 54B

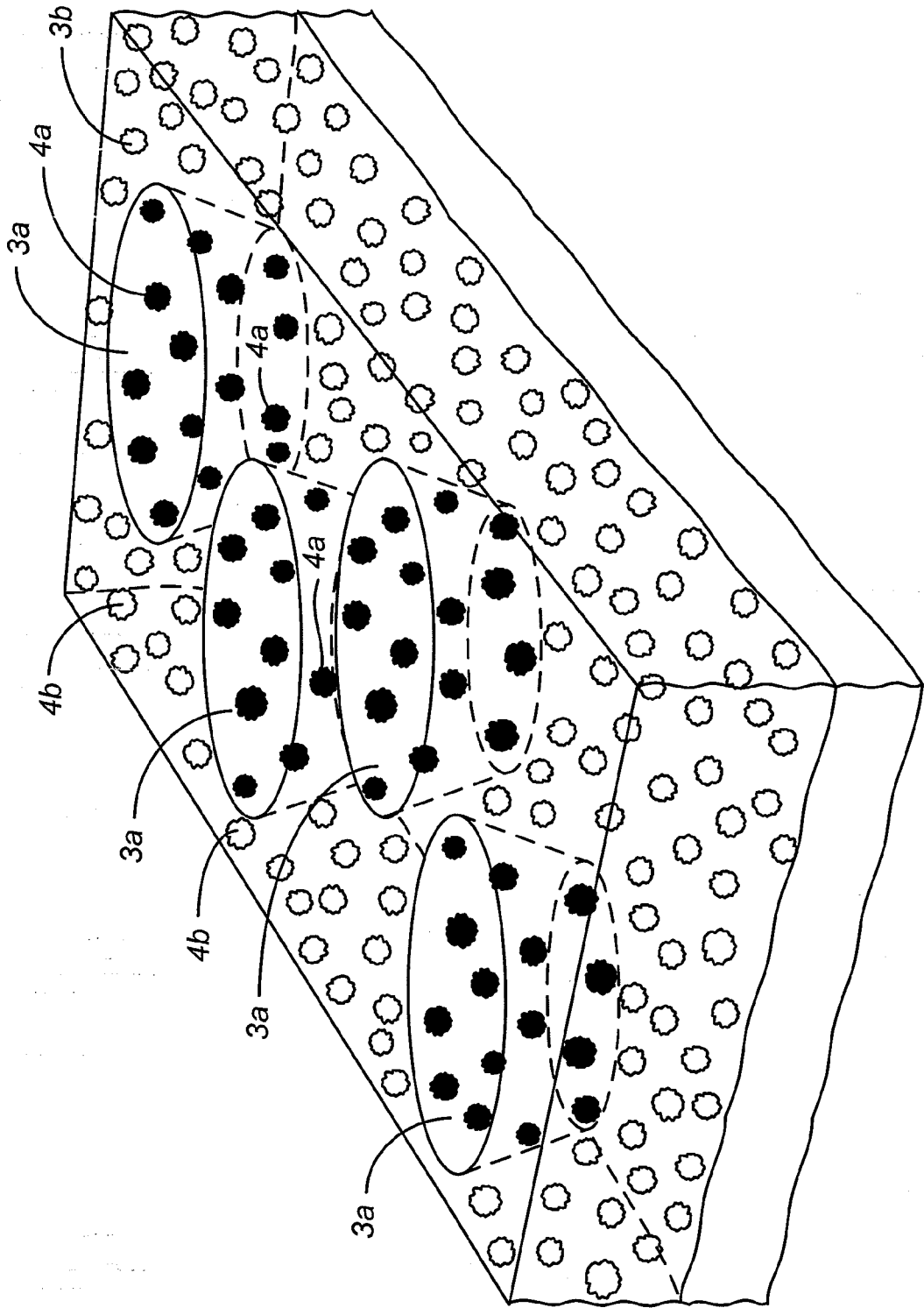
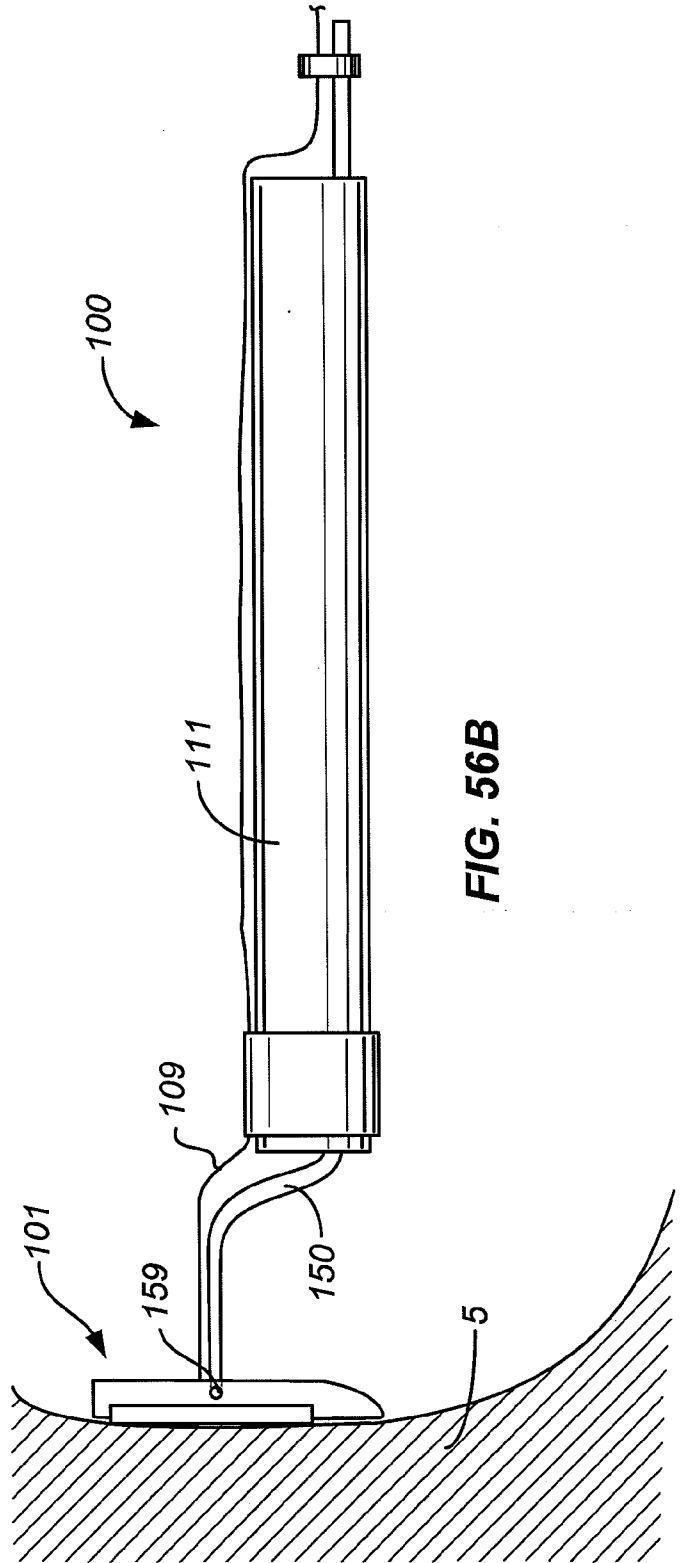
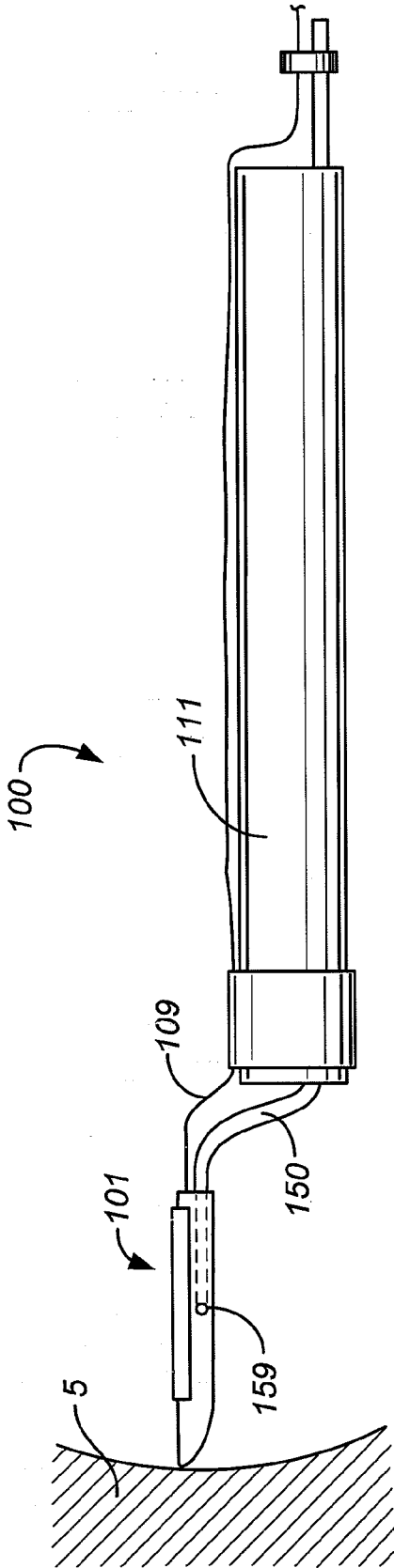

FIG. 55



38/39

FIG. 57A

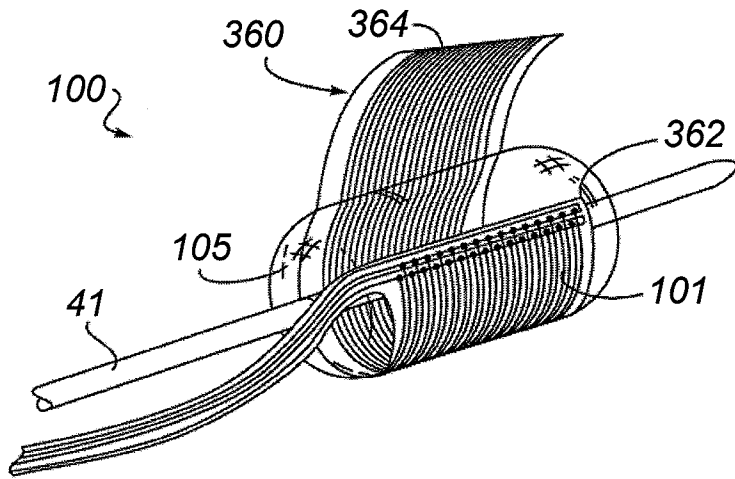

FIG. 57B

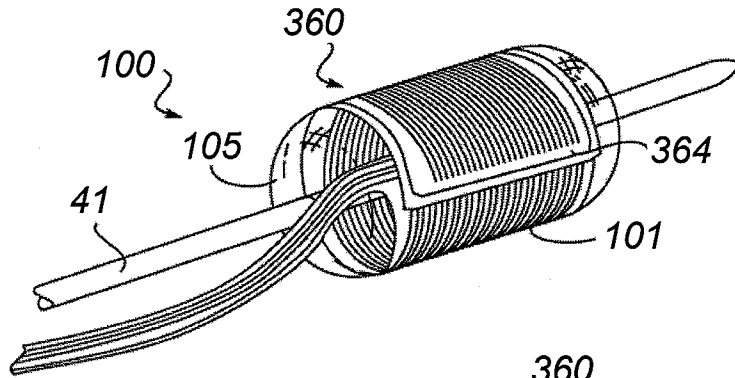

FIG. 57C

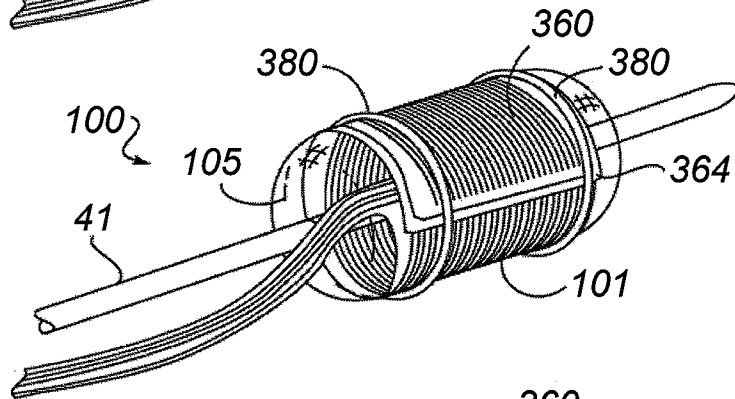
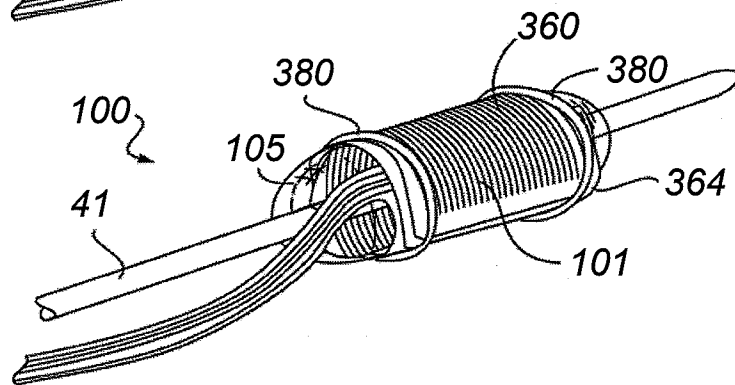

FIG. 57D



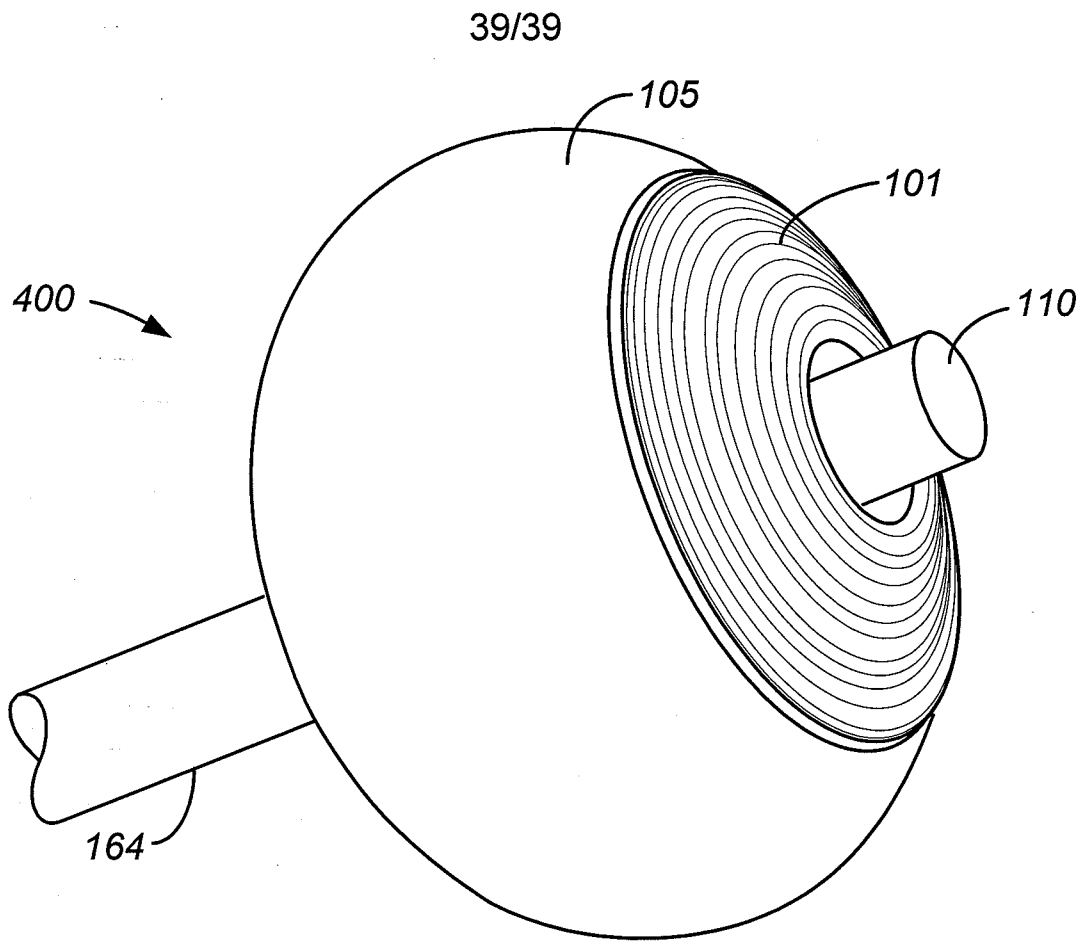

FIG. 58A

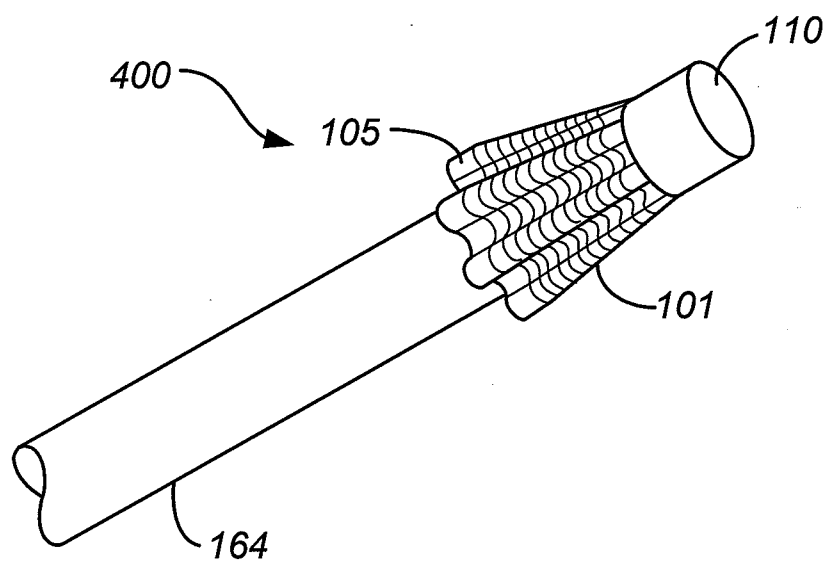

FIG. 58B

INTERNATIONAL SEARCH REPORT

International application No
PCT/US2008/069243

C(Continuation). DOCUMENTS CONSIDERED TO BE RELEVANT		
Category*	Citation of document, with indication, where appropriate, of the relevant passages.	Relevant to claim No.
X	<p>WO 2007/061984 A (BARRX INC [US]; UTLEY DAVID S [US]; GARABEDIAN ROBERT [US]; WALLACE MI) 31 May 2007 (2007-05-31) paragraphs [0006], [0007], [0015], [0073] - [0078] figures 14,15,19,21 abstract</p> <p style="text-align: center;">-----</p>	36-45

INTERNATIONAL SEARCH REPORT

International application No.
PCT/US2008/069243

Box No. II Observations where certain claims were found unsearchable (Continuation of Item 2 of first sheet)

This international search report has not been established in respect of certain claims under Article 17(2)(a) for the following reasons:

1. Claims Nos.: 1-35, 46-60
because they relate to subject matter not required to be searched by this Authority, namely:
Rule 39.1(iv) PCT - Method for treatment of the human or animal body by surgery
Rule 39.1(iv) PCT - Method for treatment of the human or animal body by therapy
2. Claims Nos.:
because they relate to parts of the international application that do not comply with the prescribed requirements to such an extent that no meaningful international search can be carried out, specifically:
3. Claims Nos.:
because they are dependent claims and are not drafted in accordance with the second and third sentences of Rule 6.4(a).

Box No. III Observations where unity of invention is lacking (Continuation of item 3 of first sheet)

This International Searching Authority found multiple inventions in this international application, as follows:

1. As all required additional search fees were timely paid by the applicant, this international search report covers all searchable claims.
2. As all searchable claims could be searched without effort justifying an additional fees, this Authority did not invite payment of additional fees.
3. As only some of the required additional search fees were timely paid by the applicant, this international search report covers only those claims for which fees were paid, specifically claims Nos.:
4. No required additional search fees were timely paid by the applicant. Consequently, this international search report is restricted to the invention first mentioned in the claims; it is covered by claims Nos.:

Remark on Protest

- The additional search fees were accompanied by the applicant's protest and, where applicable, the payment of a protest fee.
- The additional search fees were accompanied by the applicant's protest but the applicable protest fee was not paid within the time limit specified in the invitation.
- No protest accompanied the payment of additional search fees.

INTERNATIONAL SEARCH REPORT

Information on patent family members

International application No

PCT/US2008/069243

Patent document cited in search report	A1	Publication date	AU	Patent family member(s)	Publication date
US 2003153905	A1	14-08-2003	AU	3824102 A	31-07-2003
WO 0069376	A	23-11-2000	AU	5275600 A	05-12-2000
			EP	1180004 A1	20-02-2002
			US	2008108988 A1	08-05-2008
			US	2005183732 A1	25-08-2005
WO 2007061984	A	31-05-2007	AU	2006318617 A1	31-05-2007
			CA	2630565 A1	31-05-2007
			EP	1956993 A2	20-08-2008