

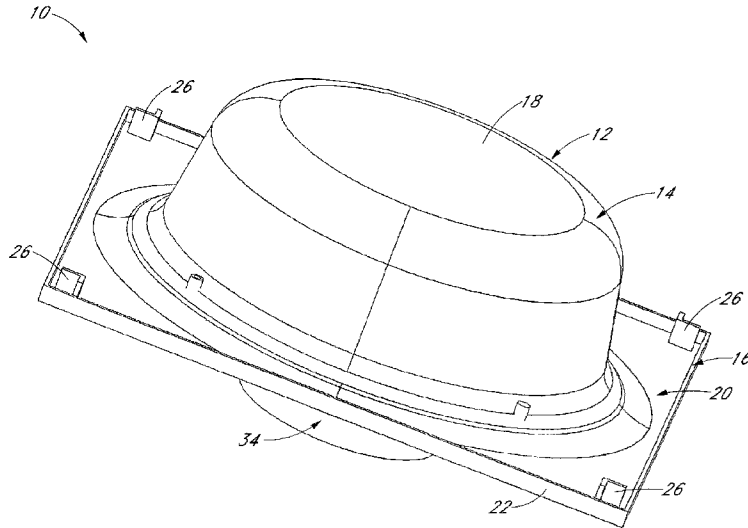

(22) Date de dépôt/Filing Date: 2014/12/18
(41) Mise à la disp. pub./Open to Public Insp.: 2015/06/19
(45) Date de délivrance/Issue Date: 2022/04/19
(30) Priorité/Priority: 2013/12/19 (US61/918,602)

(51) Cl.Int./Int.Cl. *F04D 25/08* (2006.01),
F04D 25/06 (2006.01), *F24F 7/007* (2006.01)
(72) Inventeur/Inventor:
AVEDON, RAYMOND B., US
(73) Propriétaire/Owner:
AIRIUS IP HOLDINGS, LLC, US
(74) Agent: BERESKIN & PARR LLP/S.E.N.C.R.L.,S.R.L.

(54) Titre : DISPOSITIFS, SYSTEMES ET PROCESSES DE DEPLACEMENT D'AIR EN COLONNE
(54) Title: COLUMNAR AIR MOVING DEVICES, SYSTEMS AND METHODS



(57) Abrégé/Abstract:

An air moving system includes an air moving device including a housing member, a rotary fan assembly, and an opening for connection with an airflow duct, the housing including a plurality of air intake vents. A first volume of air can enter the housing through the opening and a second volume of air can enter the housing through the plurality of intake vents. The rotary fan assembly directs the first and second volumes of air.

COLUMNAR AIR MOVING DEVICES, SYSTEMS AND METHODS

ABSTRACT OF THE DISCLOSURE

An air moving system includes an air moving device including a housing member, a rotary fan assembly, and an opening for connection with an airflow duct, the housing including a plurality of air intake vents. A first volume of air can enter the housing through the opening and a second volume of air can enter the housing through the plurality of intake vents. The rotary fan assembly directs the first and second volumes of air.

COLUMNAR AIR MOVING DEVICES, SYSTEMS AND METHODS

BACKGROUND OF THE INVENTIONS

Field of the Inventions

[0001] The present application relates generally to systems, devices and methods for moving air that are particularly suitable for creating air temperature de-stratification within a room, building, or other structure.

Description of the Related Art

[0002] The rise of warm air and the sinking of cold air can create significant variation in air temperatures between the ceiling and floor of buildings with conventional heating, ventilation and air conditioning systems. Air temperature stratification is particularly problematic in any spaces with any ceilings such as warehouses, gymnasiums, offices, auditoriums, hangers, commercial buildings, offices, residences with cathedral ceilings, agricultural buildings, and other structures, and can significantly increase heating and air conditioning costs. Structures with both low and high ceiling rooms can often have stagnant or dead air, as well, which can further lead to air temperature stratification problems.

[0003] One proposed solution to air temperature stratification is a ceiling fan. Ceiling fans are relatively large rotary fans, with a plurality of blades, mounted near the ceiling. The blades of a ceiling fan have a flat or airfoil shape. The blades have a lift component that pushes air upwards or downwards, depending on the direction of rotation, and a drag component that pushes the air tangentially. The drag component causes tangential or centrifugal flow so that the air being pushed diverges or spreads out. Conventional ceiling fans are generally ineffective as an air de-stratification device in relatively high ceiling rooms because the air pushed by conventional ceiling fans is not maintained in a columnar pattern from the ceiling to the floor, and often disperses or diffuses well above the floor.

[0004] Another proposed solution to air temperature stratification is a fan connected to a vertical tube that extends substantially from the ceiling to the floor. The fan

can be mounted near the ceiling, near the floor or in between. This type of device can push cooler air up from the floor to the ceiling or warmer air down from the ceiling to the floor. Such devices, when located away from the walls in an open space in a building, interfere with floor space use and are not aesthetically pleasing. When confined to locations only along the walls of an open space, such devices may not effectively circulate air near the center of the open space. Examples of fans connected to vertical tubes are disclosed in U.S. Patent No. 3,827,342 to Hughes, and U.S. Patent No. 3,973,479 to Whiteley.

[0005] A more practical solution is a device, for example, with a rotary fan that minimizes a rotary component of an air flow while maximizing axial air flow quantity and velocity, thereby providing a column of air that flows from a high ceiling to a floor in a columnar pattern with minimal lateral dispersion without a physical transporting tube. Examples of this type of device are described in U.S. Patent Application No. 12/130,909, filed May 30, 2008, and U.S. Patent No. 8616842, filed March 16, 2010.

SUMMARY OF THE INVENTION

[0006] An aspect of at least one of the embodiments disclosed herein includes the realization that it would be beneficial to have a columnar air moving device that has a low vertical profile, such that the device can fit into the ceiling structure of a building without extending below the ceiling to an extent that it is distracting or obstructive, and can fit within two generally horizontal ceiling structures.

[0007] Another aspect of at least one of the embodiments disclosed herein includes the realization that it would be beneficial to have a columnar air moving device that is designed specifically to fit within a ceiling grid structure, such that it is easy to install, remove, and replace the columnar air moving device if required.

[0008] Another aspect of at least one of the embodiments disclosed herein includes the realization that rooms within a building often have support beams or other structures that can make it difficult to install a columnar air moving device (or devices) within the room and direct the air to a pre-defined area. It would be advantageous to have a columnar air moving device that is configured to have a nozzle or other structure that can be

rotated or moved, so as to direct the column of air towards a desired area generally away from an area directly below the columnar air moving device.

[0009] Thus, in accordance with at least one embodiment described herein, an air moving system can comprise a ceiling structure comprising a first ceiling level forming a base portion of the ceiling, the first ceiling level having a plurality of grid cells, each grid cell bordered by a grid cell periphery structure, the ceiling structure further comprising a second ceiling level separated from the first ceiling level by a first height, an air moving device positioned at least partially within one of the grid cells in the first ceiling level, the air moving device comprising a housing member forming an interior space within the air moving device, the housing member having a top surface, the housing member being positioned within the ceiling structure such that the top surface is located between the first and second ceiling levels, a lip member forming an outer peripheral edge of air moving device, at least part of the lip member supported by the grid cell periphery structure, the housing member comprising a plurality of air vents for directing a volume of air into the interior space of the air moving device, a rotary fan assembly mounted in the interior space, the rotary fan assembly comprising an impeller and a plurality of blades, the rotary fan assembly configured to direct the volume of air within the interior space, and a nozzle communicating with and extending downwardly from the rotary fan assembly, the nozzle comprising a structure for further directing the volume of air out of the air moving device.

[0010] In accordance with at least another embodiment, an air moving device can comprise a housing member forming an interior space within the air moving device, the housing member comprising a plurality of air vents for directing a volume of air into the interior space of the air moving device, a rotary fan assembly mounted in the interior space, the rotary fan assembly comprising an impeller and a plurality of blades, the rotary fan assembly configured to direct the volume of air within the interior space, and a nozzle communicating with and extending downwardly from the rotary fan assembly, the nozzle comprising a structure for further directing the volume of air out of the air moving device, wherein the air moving device comprises a longitudinal axis, the housing member comprises an opening for insertion of the nozzle, and the nozzle comprises at least one spherical surface

configured to fit within the opening such that the nozzle can be adjusted preferably at various angles relative to the longitudinal axis.

[0011] In accordance with at least one embodiment described herein, an air moving device can include a housing member forming an interior space within the air moving device, the housing member having a first opening for fluidly connecting the interior space with an air flow duct and for directing a first volume of air from the air flow duct into the interior space, and a second opening having a plurality of air vents for directing a second volume of air into the interior space of the housing member. The air moving device can also include a rotary fan assembly mounted in the interior space, the rotary fan assembly having an impeller and a plurality of blades, the rotary fan assembly configured to direct the first and second volumes of air within the interior space.

[0012] In accordance with at least one embodiment described herein, an air moving device can include a housing member forming an interior space within the air moving device, the housing member having an opening that fluidly connects the interior space with air outside of the housing; a ceiling support structure connected to the housing member and forming an outer peripheral edge of the air moving device; and an air vent grill assembly configured to be positioned at least partially within the housing member, the air vent grill assembly having an outer rim, a plurality of air vents for directing a volume of air into the interior space of the air moving device, and at least one projection configured to releasably attach to the ceiling support structure, the projection including a hinge that allows the air vent grill assembly to rotate relative to the ceiling support structure.

[0013] In accordance with at least one embodiment described herein, a method of removing an air vent grill assembly from an air moving device can include: disconnecting a first portion (e.g., an outer rim) of an air vent grill assembly from a ceiling support structure of an air moving device, wherein the air vent grill assembly comprises at least one projection extending from the first portion and releasably attached to the ceiling support structure; rotating the first portion about a hinge in the at least one projection; disconnecting the at least one projection from the ceiling support structure; and removing the air vent grill assembly from the ceiling support structure.

BRIEF DESCRIPTION OF THE DRAWINGS

[0014] These and other features and advantages of the present embodiments will become more apparent upon reading the following detailed description and with reference to the accompanying drawings of the embodiments, in which:

[0015] Figure 1 is a top perspective view of an air moving device in accordance with an embodiment;

[0016] Figure 2 is a bottom perspective view of the air moving device of Figure 1;

[0017] Figure 3 is a front elevation view of the device of Figure 1;

[0018] Figure 4 is a top plan view of the device of Figure 1;

[0019] Figure 5 is a bottom plan view of the device of Figure 1;

[0020] Figure 6 is a perspective, partial view of the device of Figure 1, taken along line 6-6 in Figure 3;

[0021] Figure 7 is a perspective, partial view of the device of Figure 1, taken along line 7-7 in Figure 3;

[0022] Figure 8 a perspective, partial view of the device of Figure 1, taken along line 8-8 in Figure 3;

[0023] Figure 9 is cross-sectional view of the device of Figure 1, taken along line 9-9 in Figure 3;

[0024] Figure 10 is a schematic, cross-sectional view of an air moving device in accordance with an embodiment;

[0025] Figure 11 is a schematic, perspective view of an air moving system in accordance with an embodiment;

[0026] Figure 12 is a schematic, front elevational view of the air moving system of Figure 11;

[0027] Figure 13 is a schematic front view of an air moving system in accordance with one embodiment;

[0028] Figure 14 is a schematic top perspective view of an upper housing section in accordance with one embodiment;

[0029] Figure 15 is a schematic bottom perspective view of the upper housing section of Figure 14;

[0030] Figure 16 is a top perspective view of an upper housing section in accordance with one embodiment;

[0031] Figure 17 is a side view of the upper housing section of Figure 16;

[0032] Figure 18 is a schematic perspective view of an air moving device in accordance with one embodiment;

[0033] Figure 19A is a top perspective view of a removable grill assembly in accordance with one embodiment;

[0034] Figure 19B is a view of the connecting projection of Figure 19A.

[0035] Figure 20 is a cross-sectional view of the air moving device of Figure 18, taken along the line 20-20;

[0036] Figure 21 is a schematic front perspective view of the air moving device of Figure 18 with a grill assembly in an open position;

[0037] Figure 22 is a schematic side view of the air moving device of Figure 21; and

[0038] Figure 23 is a schematic side view of the air moving device of Figure 22 with the grill assembly separated from the housing member.

DETAILED DESCRIPTION OF THE PREFERRED EMBODIMENTS

[0039] With reference to Figures 1-5, an air moving device 10 can comprise a housing member 12. The housing member 12 can form an outer shell of the air moving device 10, and can at least partially enclose an interior space within the air moving device 10. The housing member 12 can be formed from one or more sections. For example, the housing member 12 can comprise an upper housing section 14, and a lower housing section 16. In some embodiments the upper and lower housing sections 14, 16 can be attached to one another through use of fasteners, adhesive, or other structure. In some embodiments the upper housing section 14 can comprise a dome shape. In some embodiments, the upper housing section 14 can comprise a generally round, circumferentially-shaped structure, and the lower housing section 16 can comprise a generally rectangular-shaped structure. In some

embodiments the lower housing section 16 can form an outer periphery of the housing member 12. In some embodiments, the dome shaped upper housing section 14 and rectangular-shaped lower housing section 16 can be integrally formed as a single piece.

[0040] The housing member 12 can include a top surface 18. In some embodiments the top surface 18 can include or be attached to a support member. The support member can include, for example, a ring-shaped structure (e.g. an eye-bolt as illustrated in Figure 10). In some embodiments, the housing member 12 can be hung by the support member, and/or can be attached to another structure with the support member. In some embodiments, and as described further below, the top surface 18, and/or any support member formed from or attached to top surface 18, can be configured to rest between two generally horizontal ceiling structures within an air moving system.

[0041] With reference to Figures 1-5, the housing member 12 can comprise a ceiling support structure 20. The ceiling support structure 20 can form part of the lower housing section 16. The ceiling support structure 20 can be a separate component attached to the housing member 12. In some embodiments, the ceiling support structure 20 can comprise a lip member. The ceiling support structure 20 can include an outer peripheral edge 22. The outer peripheral edge 22 of the ceiling support structure 20 can form a generally rectangular structure around the air moving device 10, though other shapes are also possible. The outer peripheral edge 22 can form an outer peripheral edge of the air moving device 10. The ceiling support structure 20 can also include a lower surface 24. At least a portion of the lower surface 24 can be configured to rest upon one or more ceiling structures when the air moving device 10 is mounted in a ceiling. The lower surface 24 can be a generally flat surface, though other surfaces are also possible.

[0042] With continued reference to Figures 1-5, the ceiling support structure 20 can include one or more seismic connect tabs 26. The seismic connect tabs 26 can be used to connect the air moving device 10 to one or more ceiling structures in a ceiling. The seismic connect tabs 26 can permit movement of the air moving device 10 relative to one or more ceiling structures during the event of an earthquake or other similar event.

[0043] With continued reference to Figures 1-5 and 9, the housing member 12 can comprise at least one air vent 28. The air vent or vents 28 can be configured to direct a

volume of air into the interior space of the air moving device 10. For example, the housing member 12 can comprise a plurality of air vents 28 in the lower housing section 16. The plurality of air vents 28 can be spaced directly below the ceiling support structure 20. In some embodiments the air vents 28 can be separated by air vent guides 30. The air vent guides 30 can comprise ring-like structures extending generally circumferentially along the lower housing section 16. In some embodiments the outer diameters of the air vent guides 30 can decrease moving downwardly away from the ceiling support structure 20.

[0044] The air vent guides 30 can be connected to air vent face plates 32. The air vent face plates 32 can be spaced circumferentially around the lower housing section 16. The air vent face plates 32, in conjunction with the air vent guides 30, can be configured to direct a volume of air inwardly through the air vents 28, and up into the interior space defined by the housing member 12. The air vent face plates 32 can be solid structures that divide the air vents 28 into sections or portions.

[0045] With continued reference to Figures 1-4, the air moving device 10 can comprise a nozzle 34. The nozzle 34 can communicate with and extend downwardly from the housing member 12. The nozzle 34 can comprise a structure for directing a volume of air out of the air moving device 10. For example, the nozzle 34 can comprise a structure for directing a volume of air out of the air moving device 10 that has previously entered through the plurality of air vents 28. In some embodiments, the nozzle 34 is attached to the housing member 12.

[0046] With reference to Figures 6 and 9, the air moving device 10 can comprise a rotary fan assembly 36 mounted within the interior space. The rotary fan assembly 36 can comprise an impeller 38 and a plurality of blades 40. The rotary fan assembly 36 can be configured to direct a volume of air that has entered through the plurality of air vents 28 downwardly into the nozzle 34. The rotary fan assembly 36 can push, or force, a volume of air downwardly within the interior space of the air moving device 10. The rotary fan assembly 36 can comprise a motor. The rotary fan assembly 36 can comprise at least one electrical component. The rotary fan assembly 36 can be mounted generally above the plurality of air vents 28, such that the volume of air entering the plurality of air vents 28 is required to travel upwardly within the interior space of the air moving device 10 before it can

enter the rotary fan assembly 36. In some embodiments, the rotary fan assembly 36 can be mounted to the lower housing section 16. The nozzle 34 can communicate with and extend downwardly from the rotary fan assembly 36. In some embodiments, the nozzle 34 is attached to the rotary fan assembly 36.

[0047] With continued reference to Figures 7-9, the air moving device 10 can include additional structures that facilitate de-stratification. For example, the nozzle 34 of the air moving device 10 can comprise at least one stator vane 42. The stator vanes 42 can be positioned equidistantly in a circumferential pattern within the nozzle 34. The stator vanes 42 can further direct the volume of air that has entered through the plurality of air vents 28 and has moved into the rotary fan assembly 36 and further down into the nozzle 34. For example, the stator vanes 42 can be used to straighten a volume of air within the nozzle 34. The stator vanes 42 can be used to force a volume of air to move in a generally columnar direction downwardly towards the floor of a building or other structure, with minimal lateral dispersion, similar to the devices described for example in U.S. Patent No. 12/130,909, and U.S. Patent Application No. 12/724,799. In some embodiments, the nozzle 34 can have no stator vanes 42. In some embodiments, the stator vanes can be straight. In some embodiments, the stator vanes can be curved or include a curved portion.

[0048] With reference to Figure 9, in some embodiments the stator vanes 42 can comprise one or more cutouts 44. The cutouts 44 can create space for insertion, for example, of an ionization cell (i.e. a PHI cell). The ionization cell can be used to increase the air quality. The cutouts 44 can form a void or opening in the middle of the nozzle 34, and the ionization cell (not shown) can be inserted into the opening for example during manufacturing. The volume of air moving through the air moving device 10 can run past, alongside, or through the ionization cell, and be treated.

[0049] With continued reference to Figures 3 and 9, in some embodiments the air moving device 10 can comprise a longitudinal axis L that runs through a middle of the air moving device 10. The housing member 12 can comprise an opening 46 for insertion of the nozzle 34, and the nozzle 34 can comprise at least one spherical surface 48 configured to fit within the opening 46 such that the nozzle 34 can be adjusted angularly relative to the longitudinal axis L. For example, the nozzle 34 can rest within the opening 46, such that the

spherical surface 48 contacts the housing member 12, and is not rigidly attached to the housing member 12. In this manner, the housing member 12 can act as a gimbol, allowing pivoted rotational and/or tilting movement of the nozzle 34. The nozzle 34 can be moved at an angle or angles relative the longitudinal axis L, so as to direct the column of air leaving the air moving device 10 towards different directions. In some embodiments, the nozzle 34 can be vertical or angled at least 10 degrees relative to the longitudinal axis L in one or more directions. In some embodiments, the nozzle 34 can be angled at least 15 degrees relative to the longitudinal axis L in one or more directions. In some embodiments the nozzle 30 can be angled at least 20 degrees relative to the longitudinal axis L in one or more directions. In some embodiments, the nozzle 34 can be angled at least 45 degrees relative to the longitudinal axis L in one or more directions. In some embodiments the nozzle 34 can self-lock in place once it has been repositioned. For example, the weight of the nozzle 34, and/or the coefficients of friction of the materials used to create the nozzle 34 and housing member 12, can be such that the nozzle 34 can frictionally lock itself in place in various positions. In some embodiments, the nozzle 34 and/or housing member 12 can incorporate one or more mechanical or other types of mechanisms for locking the nozzle 34 in place once it has been repositioned.

[0050] While use of a spherical surface on the nozzle 30 is described and illustrated, other types of mechanisms could also be used to permit relative movement of the nozzle 30, and/or to allow the nozzle 30 to be locked in place in various angular positions.

[0051] In some buildings, there are support beams, ductwork, conduit, wiring, or other structures that would otherwise block the flow of a columnar air moving device, or make it difficult for an air moving device to direct air to a desired area. Therefore, at least one benefit achieved by having a nozzle 34 that can be repositioned is the fact that the air moving device 10 can be positioned in or below a ceiling, some distance away from an area in need of de-stratification, and the nozzle 34 can simply be adjusted so as to direct the column of air towards that area of need.

[0052] With continued reference to Figure 9, the air moving device 10 can further comprise at least one anti-swirl member 50. The anti-swirl member 50 can be located within the interior space of the air moving device 10 formed by the housing member 12. In some

embodiments, one or more anti-swirl members 50 can be attached to an interior surface of the upper housing section 14. The anti-swirl members 50 can be used to slow down and/or inhibit swirling of air within the interior space located above the rotary fan assembly 36. For example air can be swirling turbulently, at a top of the air moving device 10 after it has entered the device. The anti-swirl members 50 can extend into the space where the air is moving and slow the air down, and/or redirect the air, so that the air is directed more linearly down towards the nozzle 34. It can be desirable to slow down and/or inhibit swirling of air, such that the air can be directed more easily in a generally columnar pattern down through the nozzle 34 with greater ease and efficiency. The anti-swirl members 50 can be used to inhibit turbulence within the air moving device 10. In some embodiments, the anti-swirl members 50 can comprise one or more ribs. The ribs can extend along an inside surface of the housing member 12. The ribs can inhibit a swirling pattern of air.

[0053] In some embodiments, the air moving device 10 can be a self-contained unit, not connected to any ductwork, tubing, or other structure within a room or building. The air moving device 10 can be a stand-alone de-stratification device, configured to de-stratify air within a given space.

[0054] In some embodiments, the air moving device 10 can have an overall height (extending from the top of the housing member 12 to the bottom of the nozzle 34) that ranges from between approximately one foot to four feet, though other ranges are also possible. For example, in some embodiments the air moving device 10 can have an overall height that ranges from approximately one feet to three feet. In some embodiments the housing member 12 can have an overall outside diameter that ranges from approximately 8 inches to 30 inches, though other ranges are also possible. For example, in some embodiments the housing member 12 can have an overall outside diameter that ranges from approximately 12 inches to 24 inches. In some embodiments, the nozzle 30 can have an outside diameter that ranges between approximately five inches to twelve inches, though other ranges are possible. For example, in some embodiments the nozzle 30 can have an outside diameter that ranges from between approximately eight to ten inches. In some embodiments the air moving device 10 can have a motor with an overall power that ranges between approximately 720 and 760 watts, though other ranges are possible. In some

embodiments the air moving device 10 can have a motor with an overall power that can vary from approximately 10 to 740 watts.

[0055] With reference to Figures 11 and 12, an air moving system 110 can comprise a first ceiling level 112 forming a base portion of a ceiling in a building or room. The first ceiling level 112 can comprise a plurality of grid cells 114. Each of the grid cells 114 can be bordered by at least one grid cell periphery structure 116. In some embodiments, at least a portion of the grid cell periphery structure 116 can have a t-shaped cross section. In some embodiments, the grid cells 114 can comprise an open space between the grid cell periphery structures 116. The grid cells 114 can be generally rectangular. In some embodiments the grid cells 114 are approximately 24 inches by 24 inches in size, though other sizes and shapes are also possible.

[0056] In some embodiments, the ceiling support structure 20 can be configured to rest on or be attached to one or more grid cell periphery structures 116. For example, in some embodiments the air moving device 10 can rest on two grid cell periphery structures 116. In some embodiments the air moving device can rest on four grid cell periphery structures 116. In some embodiments, the grid cell periphery structures 16 can be configured to support the ceiling support structure 20 and air moving device 10. In some embodiments, the grid cell periphery structures 16 are attached to the ceiling support structure 20, for example with at least one fastener. In some embodiments the grid cells 114 can have generally the same outer peripheral profile as the ceiling support structure 20, such that the ceiling support structure 20 is configured to rest on the surrounding grid cell periphery structures 116, and the air moving device 10 fits easily within a single grid cell 114. As described above, seismic connect tabs 26 can be used to provide further connection.

[0057] With reference to Figure 12, the air moving system 110 can further comprise a second ceiling level 118. The second ceiling level 118 can be separated from the first ceiling level 112 by a height H. In some embodiments, both the first and second ceiling levels 112, 118 are generally horizontal structures. In some embodiments the first and second ceiling levels 112, 118 are parallel to one another. As described above, and as illustrated in Figure 12, an air moving device 10 can be configured to fit within the air moving system 10 such that the top surface 18 is located between the first and second ceiling

levels 112, 118. The low vertical profile of the air moving device 10, and in particular the upper housing section 14, advantageously enables the air moving device to fit within this space between the first and second ceiling levels 112, 118.

[0058] Overall, the air moving system 110 can permit multiple air moving devices 10 to be supported by or attached to the grid cell periphery structures 116. The air moving devices 10 can be removed, replaced, or moved in the air moving system 110. If required, and as described above, the nozzles 34 can be moved, pivoted, and/or rotated, depending on where it is desired to direct air within a building or room having an air moving system 110.

[0059] In some embodiments, the air moving device system 110 can comprise a solid ceiling structure (e.g. a drywall structure). A portion of the ceiling structure can be removed to make room for the air moving device 10. For example, a portion of drywall or other material can be cut out, and the air moving device 10 can be supported by and/or mounted to the ceiling structure in the air moving device system 110, with at least a portion of the air moving device 10 located within the cut-out portion.

[0060] In various embodiments, an air moving device can be configured to connect to an airflow conduit or duct, such as those used as part of a heating, ventilation, and air conditioning (HVAC) system; a heating, ventilation, air conditioning, and refrigeration (HVACR) system; or other environmental control system. In such embodiments, the air moving device can be configured to direct air from the airflow conduit to a desired location. For example, in some embodiments an air moving device can be configured to direct warm air from an airflow conduit toward the entrance of a building. This can help keep the floor of the entrance dry and help ensure that individuals entering the building immediately experience the conditioned air.

[0061] In some embodiments, an air moving device can also help maintain pressure in the airflow conduit or duct. For example, where an air moving device is connected to a conduit or duct toward the end of the conduit or duct (or other location where pressure tends to fall), a rotary fan assembly in the air moving device can create a negative pressure that draws air to the end of the conduit or duct. Further, operating a rotary fan assembly in an air moving device while operating an HVAC (or other environmental control

system) can lead to efficient movement of air since both the fan assembly and pressure within the HVAC conduits help move air. Additionally, if one of the fan assembly or the HVAC system is not activated, the other of the fan assembly or the HVAC system can still help drive air flow. For example, if the HVAC system is not activated, the fan assembly can draw air into the air moving device from a room or other location where the device is located and allow the air moving device to direct the air to a desired location. In some embodiments, the fan assembly can also draw air into the air moving device from the HVAC conduit when the HVAC system is not activated. Similarly, if the fan assembly is not activated, the HVAC system can direct air through the air moving device.

[0062] Figure 13 illustrates one embodiment of an air moving device that has been configured to connect to an HVAC or other environmental control system. In some embodiments, an upper housing section 114 of the air moving device can include stubbing or a projection 160 that can be configured to attach to a conduit or duct 115 of the HVAC or other environmental control system. In some embodiments, the projection can connect directly to the conduit or duct. In some embodiments (e.g., where the position of the air moving device is not aligned with the conduit or duct), the projection can connect to a flexible attachment tubing or duct 117 that connects the projection to the conduit 115. In some embodiments, a securing device 119, such as a coil or band, can be used to secure the attachment tubing or duct 117 to the projection. In some embodiments, the upper housing section 114 can have an opening without any projection and that receives a projection from the conduit or duct 115 or from the attachment tubing or duct 117.

[0063] In some embodiments, the upper housing section 114 can be configured to have a projection 160 positioned according to the particular geometry needed for the housing member to connect to a conduit or duct 115. Figures 14 and 15 illustrate one embodiment of an upper housing section 114 that includes a projection 160 at a top of the upper housing section. The projection can have an opening 162 that can allow fluid communication between the upper housing section and an airflow duct. Figures 16 and 17 illustrate an embodiment of an upper housing section 114 with a projection 160 that extends laterally from a side of the upper housing section. In some embodiments, an opening in the projection can be sized to fit standard conduit connection points. For example, in some embodiments

the opening can have a diameter of 6 inches, 8 inches, 10 inches, or 12 inches. In some embodiments it can have other diameters. In some embodiments, it can be configured to match the particular conduit to which it will connect.

[0064] The upper housing section 114 of Figures 13-17 can be used and configured according to any embodiments discussed herein. For example, in some embodiments an air moving device that connects to a conduit or duct can also include a rotary fan assembly and at least one air vent configured to draw a volume of air from outside of the conduit and outside of the device into the interior space of the air moving device. Additionally, components not specifically called out can be considered to operate like similar components described elsewhere herein. Further, components called out with similar numbers can be considered to operate similarly unless otherwise described. For example, in some embodiments an upper housing section 114 can include one or more anti-swirl members 150 that can operate similarly to the anti-swirl members 50 discussed above.

[0065] In some embodiments, as further illustrated in Figures 16 and 17, an upper housing section 114 can include an inset portion 164 on a top of the housing member. The inset portion can define guide walls 166 in an interior of the housing member that can help direct airflow from the outer regions of the housing toward a center of the housing from where it can be directed out of the housing, such as through a nozzle. In some embodiments, the guide walls can direct airflow through a fan assembly before the air exits the housing. Any of the various embodiments described herein can be adapted to include an inset portion 164 and/or guide walls 166.

[0066] In some embodiments, it can be desirable for an air moving device to be configured to allow for the removal of various components so that they can be cleaned, adjusted, repaired, maintained, or otherwise modified as desired. Figures 18-23 relate to such embodiments. The components and features discussed with respect to Figures 18-23 can be used and configured according to any embodiments discussed herein. Components not specifically called out can be considered to operate like similar components described elsewhere herein. Further, components called out with similar numbers can be considered to operate similarly unless otherwise described. For example, in some embodiments an upper

housing section 214 or ceiling support structure 220 can include one or more seismic connect tabs 226 that can operate similarly to the seismic connect tabs 26 discussed above.

[0067] Figure 18 illustrates one embodiment of an air moving device 210 that includes a removable grill assembly 270 to assist with cleaning, adjustment, repair, or other modifications of the air moving device 210. The grill assembly can include a plurality of air vents 228 that can direct a volume of air into the interior space of the air moving device 210. The air vents can be separated by air vent guides 230. In some embodiments, the air vent guides can be circumferential, as described above. In some embodiments, as illustrated, the air vent guides 230 can extend radially. Radially extending guides 230 can reduce interference with a volume of air moving into the interior of the air moving device 210.

[0068] In some embodiments, the grill assembly 270 can be releasably secured to the housing member 212, such as by attaching to the lower housing section 216. Any form of releasable attachment can be used, such as clips, bolts, screws, interlocking components, etc. As shown, in some embodiments screws 278 can be used to secure the grill assembly 270. The screws can be inserted through an outer rim 272 of the grill assembly 270 and into the lower housing section 216, such as in a ceiling support structure 220.

[0069] In some embodiments, the grill assembly 270 can also include a connecting projection 280 that can include an articulation, such as a hinge 282. The hinge can allow the grill assembly 270 to rotate out of a closed position within the housing member 212 while still remaining connected to the housing member 212. This can allow an operator or technician to clean or otherwise service components (e.g., the motor, rotary fan, vanes) within the interior of the housing member 212 and/or clean or otherwise service components of the grill assembly 270 without having to completely remove the grill assembly 210 and/or housing 212 from the ceiling. The hinge 282 can be a tool-less hinge (e.g., a hinge capable of rotation with respect to and attachment/removal from the ceiling or ceiling support structure without use of tools).

[0070] Figure 19A illustrates a top view of a grill assembly 270 and Figure 19B illustrates a connecting projection 280 of Figure 19A. In some embodiments, as shown, the connecting projection 280 can include a proximal, wider section 284 and a distal, narrower section 286. The distal section can include the hinge 282 and an elongate connection

member 288, such as a pin, that is attached to the distal section 286. Figure 20 illustrates a cross-sectional view of one embodiment of an air moving device 210 that includes a removable grill assembly 270. In some embodiments, when the grill assembly is in a closed position as shown, the connecting projection 280 can be rotated at the hinge 282. Preferably, in the closed position the grill assembly 270 can be flush or generally flush with a lower housing section 216, such as at a ceiling support structure 220. In some embodiments, as illustrated, the grill assembly does not have a nozzle. In some embodiments, the grill assembly 270 may include a nozzle according to any of the nozzle embodiments discussed above.

[0071] In some embodiments, the grill assembly 270, including any connecting projection 280, can be completely removed from the housing member 212. Figures 21-23 illustrate various steps to removing a grill assembly. Figure 21 is a front view and Figure 22 is a side view of an air moving device 210 with a grill assembly 270 rotated from a closed to an open position. Figure 23 is a side view of an air moving device 210 with a grill assembly 270 completely removed from the housing member.

[0072] With reference to Figures 21 and 22, in some embodiments, before rotating the grill assembly 270, any connecting mechanisms (e.g., screws) between the grill assembly and the housing member 212 are removed or released. The grill assembly 270 can then be rotated about the hinge 282 into the open position. In some embodiments, the ceiling support structure 220 of the housing member can include a seat 223 that can be sized and configured to receive a corresponding lip 274 of the outer rim 274 of the grill assembly.

[0073] In some embodiments, the grill assembly 270 can include a rotary fan assembly 236, such that the fan assembly can be removed with the grill assembly 270 for easy cleaning, repair, maintenance, etc. This can decrease the cost associated with maintaining the air moving devices within a building as fewer people and working hours are required to remove and maintain the grill assembly, including a fan assembly, and because the whole air moving device does not need to be removed for maintenance. In some embodiments, the fan assembly can be plugged into an outlet either within or outside of the housing member 212 with a cord long enough to allow the fan assembly 236 to rotate as illustrated. In some embodiments, the grill assembly 270 can be separate from the fan

assembly 236 and can be removed independently. Preferably, when the grill assembly 270 and fan assembly 236 are removed together, they can be later separated to allow for specific maintenance tasks. In some embodiments, the fan assembly 236 can include at least one spherical surface 248 that can be configured to fit within an opening 246 of the grill assembly to thereby allow the grill assembly 270 to act as a gimbal, as described above.

[0074] In some embodiments, as illustrated for example in Figure 22, the ceiling support 220 can include one or more openings or slots 221 configured to receive the connecting projections 280 when the grill assembly 270 is in a closed position. Preferably, as shown in Figure 18, in the closed position the connecting projections 180 can be flush or generally flush against the lower surface of the ceiling support 220. The openings 221 can have a first, wider portion 225 and a second, narrower portion 227. In some embodiments, the wider portion 225 can be approximately the same width as the wider section 284 of the connecting projection 280. In some embodiments, the narrow portion 227 can be approximately the same width as the narrow section 286 of the connecting projection.

[0075] Preferably, the connection member 288 at a distal end of the connecting projection 280 has a width wider than that of the narrow portion 227, but not as wide as that of the wide portion 225. Thus, when the grill assembly 270 has been rotated into the position shown in Figure 22, the connection member 288 cannot pass through the narrow portion 227 and the grill assembly is prevented from being separated from the housing member 212. However, the grill assembly 270 can be translated laterally until the connecting projection 280 is aligned with the wide portion 225 of the opening 221. Where the connection member 288 is narrower than the width of the wide portion 225, the connection member can pass through the opening 221 and the grill assembly 270 can be removed from the housing member 212, as shown in Figure 23.

[0076] The grill assembly 270 can then be cleaned, further taken apart, repaired, or otherwise modified and then re-attached to the housing member 212. To re-attach, the connecting projection 280 is merely inserted through the wider portion 225 of the opening 221, the device is translated laterally until the connecting projection is at an outer end with the narrow portion 227, and then the grill assembly is rotated at the hinge until it is in a closed position, such as that shown in Figure 20. It will be understood that the foregoing

disassembly/maintenance methods may be performed while the air moving device 210 is installed in a ceiling. For example, the grill assembly 270 can be swung downward from the lower housing section 216 while the air moving device 210 is installed within the ceiling.

[0077] The terms “approximately”, “about”, and “substantially” as used herein represent an amount close to the stated amount that still performs a desired function or achieves a desired result. For example, the terms “approximately”, “about”, and “substantially” may refer to an amount that is within less than 10% of, within less than 5% of, within less than 1% of, within less than 0.1% of, and within less than 0.01% of the stated amount.

[0078] Although these inventions have been disclosed in the context of certain preferred embodiments and examples, it will be understood by those skilled in the art that the present inventions extend beyond the specifically disclosed embodiments to other alternative embodiments and/or uses of the inventions and obvious modifications and equivalents thereof. In addition, while several variations of the inventions have been shown and described in detail, other modifications, which are within the scope of these inventions, will be readily apparent to those of skill in the art based upon this disclosure. It is also contemplated that various combinations or sub-combinations of the specific features and aspects of the embodiments can be made and still fall within the scope of the inventions. It should be understood that various features and aspects of the disclosed embodiments can be combined with or substituted for one another in order to form varying modes of the disclosed inventions. Thus, it is intended that the scope of at least some of the present inventions herein disclosed should not be limited by the particular disclosed embodiments described above.

CLAIMS

1. An air moving device comprising:
 - a housing member forming an interior space within the air moving device, the housing member having an opening that fluidly connects the interior space with air outside of the housing;
 - a ceiling support structure connected to the housing member and forming an outer peripheral edge of the air moving device;
 - an air vent grill assembly configured to be positioned at least partially within the housing member, the air vent grill assembly comprising a plurality of air vents for directing a volume of air into the interior space of the air moving device, and at least one projection configured to releasably attach to the ceiling support structure, the projection including a tool-less hinge that allows the air vent grill assembly to rotate relative to the ceiling support structure to a downward position when the air moving device is positioned at least partially within a ceiling structure, wherein the air vent grill assembly is supported by the tool-less hinge positioned when the air vent grill assembly is in the downward position, but wherein the tool-less hinge is configured to enable the air vent grill assembly to be removable from the ceiling support structure without use of tools; and
 - a rotary fan assembly including an impeller mounted on the air vent grill assembly within the interior space of the housing member, wherein the rotary fan assembly and impeller are configured to rotate with the air vent grill assembly when the air vent grill assembly rotates relative to the ceiling support structure about the tool-less hinge;
 - wherein the ceiling support structure comprises at least one attachment opening configured to receive at least a portion of the at least one projection, and wherein the at least one attachment opening comprises a first portion having a first width and a second portion having a second width less than the first width.
2. The air moving device of claim 1, wherein the at least one projection comprises an elongate connector at one end, the elongate connector having a width less than the first width but greater than the second width.

3. The air moving device of claim 1, wherein the at least one projection comprises a first portion having a first width and a second portion having a second width less than the first width of the at least one projection.

4. The air moving device of claim 3, wherein the first width of the at least one projection is approximately equal to the first width of the at least one attachment opening, and wherein the second width of the at least one projection is approximately equal to the second width of the at least one attachment opening.

5. The air moving device of claim 1, further comprising one or more flow straighteners configured to straighten the volume of air to output the volume of air from the air moving device in a substantially columnar manner.

6. An air moving device comprising:

a housing member forming an interior space within the air moving device, the housing member having an opening that fluidly connects the interior space with air outside of the housing;

a ceiling support structure connected to the housing member and forming an outer peripheral edge of the air moving device;

an air vent grill assembly configured to be positioned at least partially within the housing member, the air vent grill assembly comprising a plurality of air vents for directing a volume of air into the interior space of the air moving device, and at least one projection configured to releasably attach to the ceiling support structure, the projection including a proximal portion connected to a distal portion by a first hinge, wherein the projection when releasably attached to the ceiling support structure thereby forms a tool-less second hinge that allows the air vent grill assembly to rotate relative to the ceiling support structure from a horizontal position to a downward position when the air moving device is positioned at least partially within a ceiling structure of a building, wherein the air vent grill assembly is supported by the tool-less second hinge when the air vent grill assembly is positioned in the

downward position, and wherein the tool-less second hinge is configured to enable the air vent grill assembly to be removable from the ceiling support structure without use of tools; and

a rotary fan assembly including an impeller mounted on the air vent grill assembly within the interior space of the housing member, wherein the rotary fan assembly and impeller are configured to rotate with the air vent grill assembly when the air vent grill assembly rotates relative to the ceiling support structure about the tool-less second hinge and the rotary fan assembly being operable in the horizontal position without being connected to ductwork or tubing.

7. The air moving device of claim 6, wherein the ceiling support structure comprises at least one attachment opening configured to receive at least a portion of the at least one projection.

8. The air moving device of claim 6, wherein the at least one attachment opening comprises a first portion having a first width and a second portion having a second width less than the first width.

9. The air moving device of claim 8, wherein the at least one projection comprises an elongate connector at one end, the elongate connector having a width less than the first width but greater than the second width.

10. The air moving device of claim 8, wherein the at least one projection comprises a first portion having a first width and a second portion having a second width less than the first width of the at least one projection.

11. The air moving device of claim 8, wherein the first width of the at least one projection is approximately equal to the first width of the at least one attachment opening, and wherein the second width of the at least one projection is approximately equal to the second width of the at least one attachment opening.

12. The air moving device of claim 6, further comprising one or more flow straighteners configured to straighten the volume of air to output the volume of from the air moving device in a substantially columnar manner.

13. A method of cleaning an air moving device, the method comprising:
disconnecting a first portion of an air vent grill assembly from a ceiling support structure of an air moving device, wherein the air vent grill assembly comprises at least one projection extending from the first portion and releasably attached to the ceiling support structure, and wherein the air vent grill assembly comprises a rotary fan assembly;
rotating the first portion about a hinge in the at least one projection, wherein the first portion of the air vent grill assembly is configured to detach from the ceiling support structure at the hinge without using tools; and
cleaning the impeller without requiring removal of any further structure from the air moving device.

14. The method of claim 13, wherein the first portion of the air vent grill assembly is configured to detach from the ceiling support structure at the hinge without using tools by disconnecting the at least one projection from the ceiling support structure without using tools.

15. The method of claim 13, wherein the ceiling support structure comprises at least one opening configured to receive the at least one projection.

16. The method of claim 14, wherein disconnecting the at least one projection from the ceiling support structure comprises translating the air vent grill assembly laterally.

17. The method of claim 13, wherein disconnecting the first portion of the air vent grill assembly comprises removing screws joining the first portion to the ceiling support structure.

18. The method of claim 14, further comprising unplugging the rotary fan assembly before removing the air vent grill assembly from the ceiling support structure.
19. The method of claim 13, further comprising disconnecting the at least one projection from the ceiling support structure to thereby allow for removal of the air vent grill assembly and rotary fan assembly from the ceiling support structure.
20. The method of claim 13, wherein the impeller is located within a rounded enclosure having a first end adjacent the air vent grill assembly and a second opposite open end.
21. The method of claim 20, wherein cleaning comprises accessing the impeller via the open end of the enclosure.
22. A method of cleaning an air moving device, the method comprising:
rotating in a first direction an air vent grill assembly and impeller about a tool-less hinge relative to a ceiling support structure to expose the impeller for cleaning, wherein the air vent grill assembly is configured to detach from the ceiling support structure at the tool-less hinge without using tools;
cleaning the impeller; and
rotating in a second direction the air vent grill assembly and impeller about the tool-less hinge relative to the ceiling support structure to secure the air vent grill assembly with the ceiling support structure.
23. The method of claim 22, wherein the impeller is located within a rounded enclosure having a first end adjacent the air vent grill assembly and a second opposite open end.
24. The method of claim 23, further comprising cleaning the impeller via the open end of the enclosure.

25. The method of claim 22, wherein the tool-less hinge comprises at least one projection extending from the air vent grill assembly releasably attached to the ceiling support structure.
26. The method of claim 22, further comprising disconnecting the air vent grill assembly and impeller from the ceiling support structure.

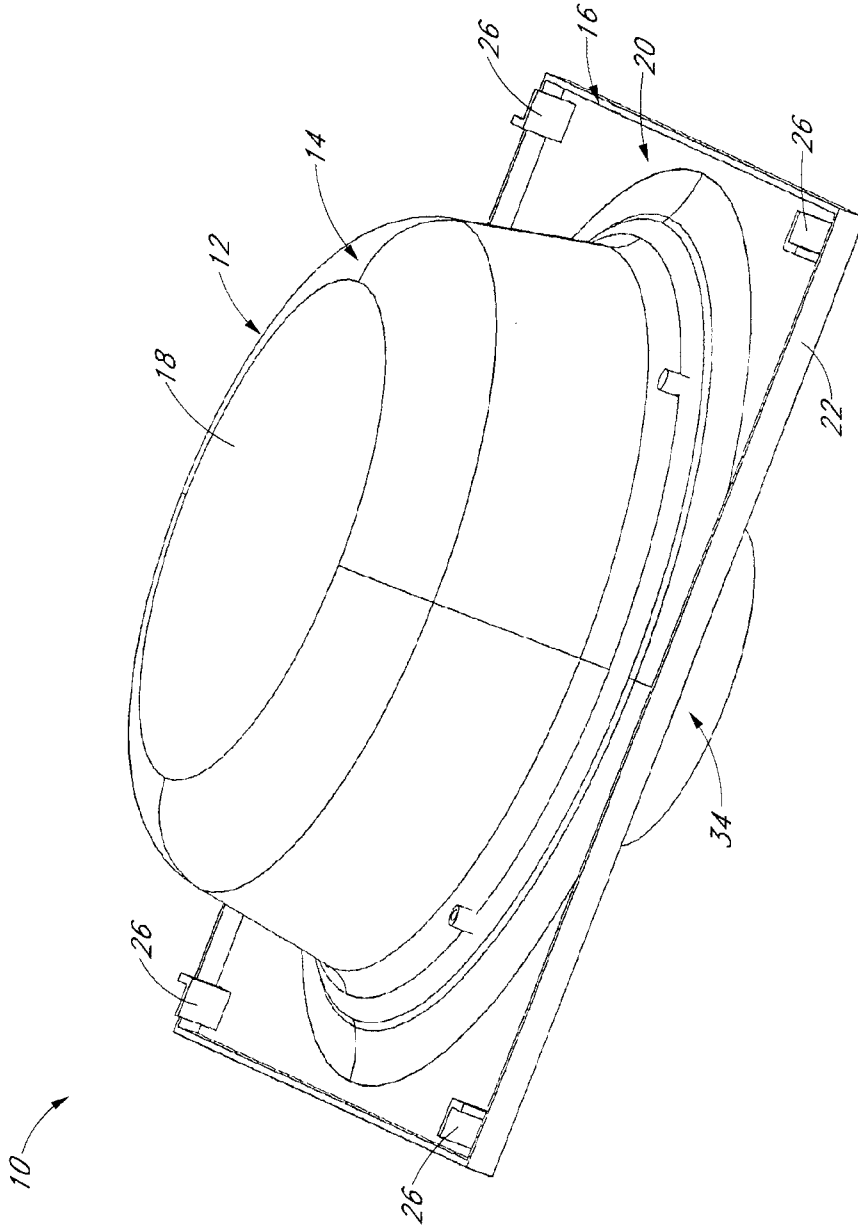

FIG. 1

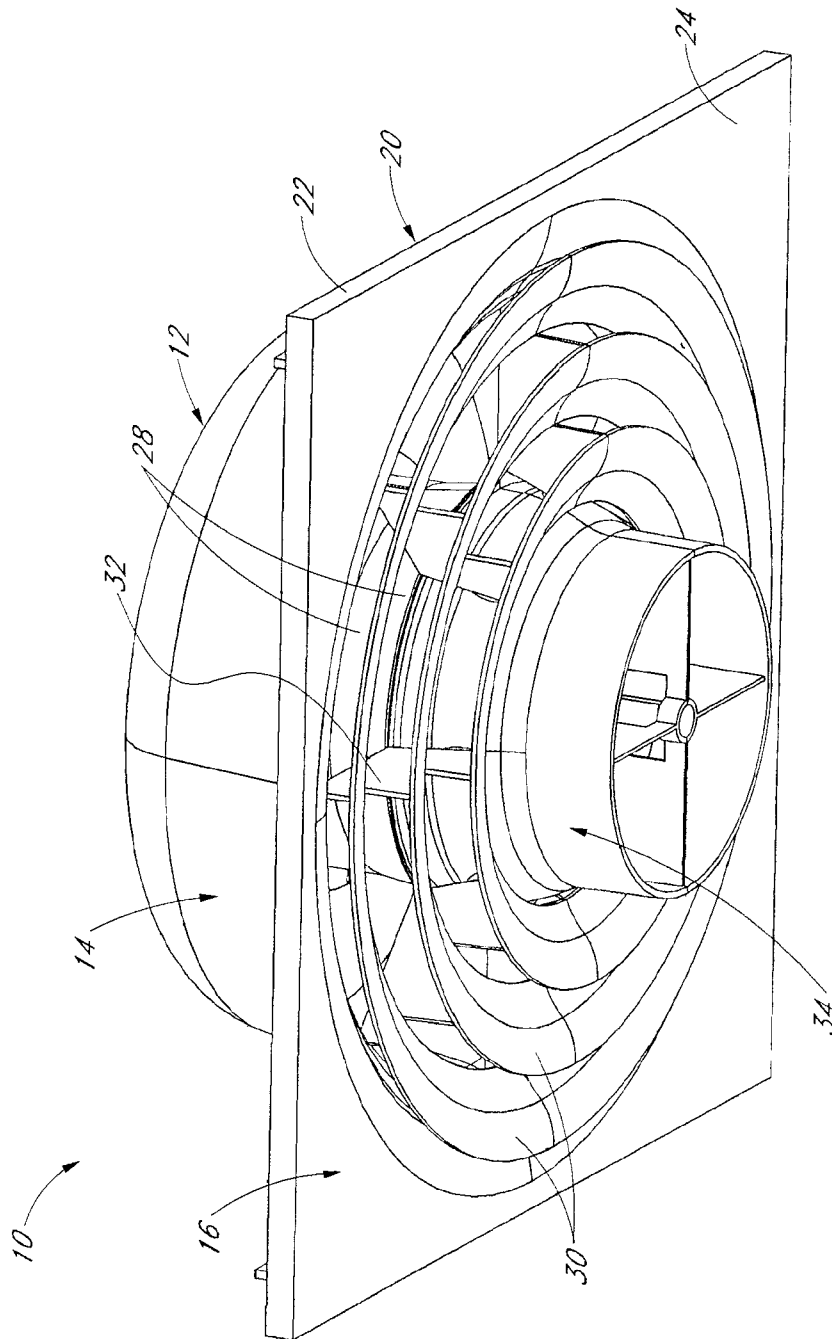

FIG. 2

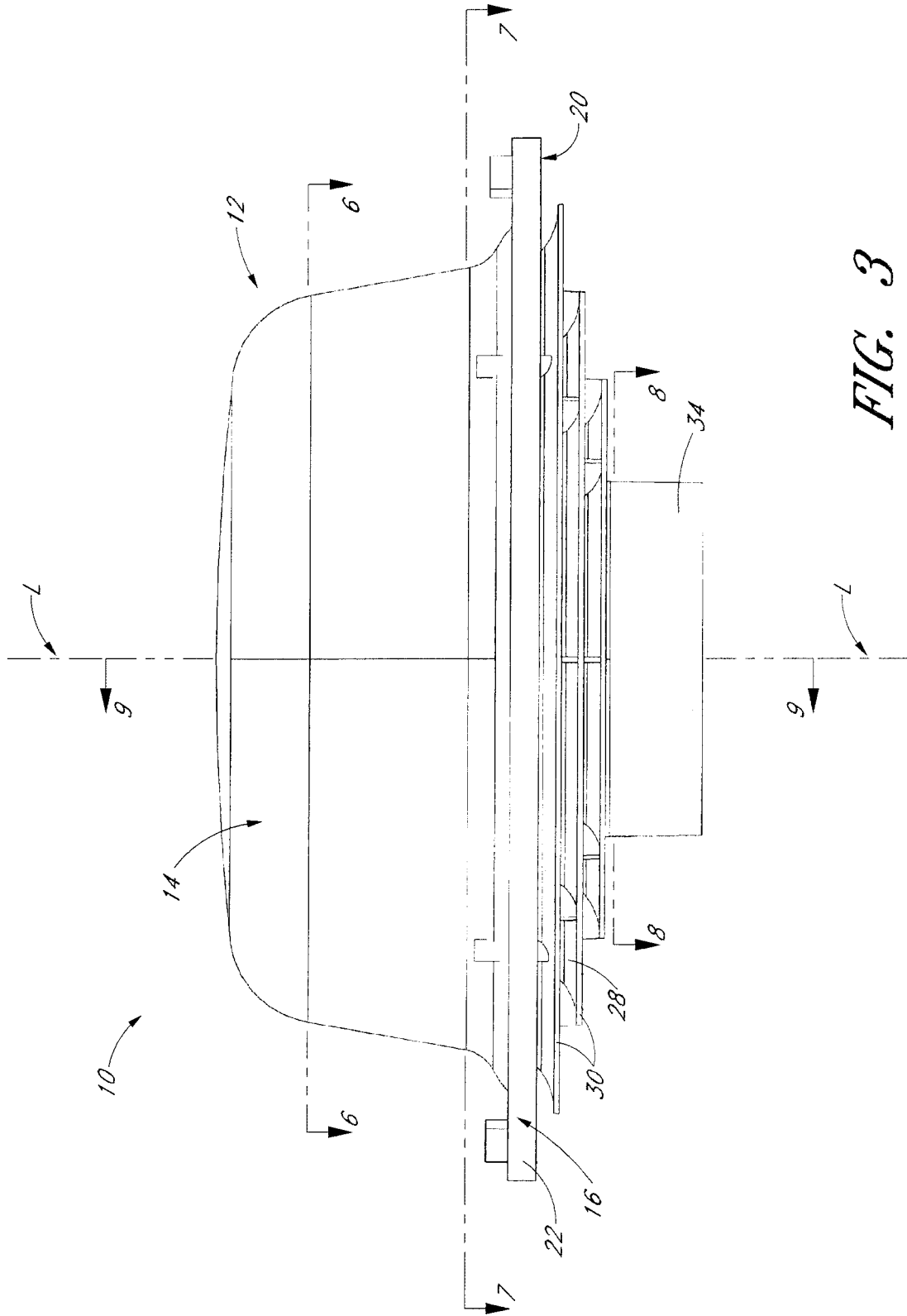

FIG. 3

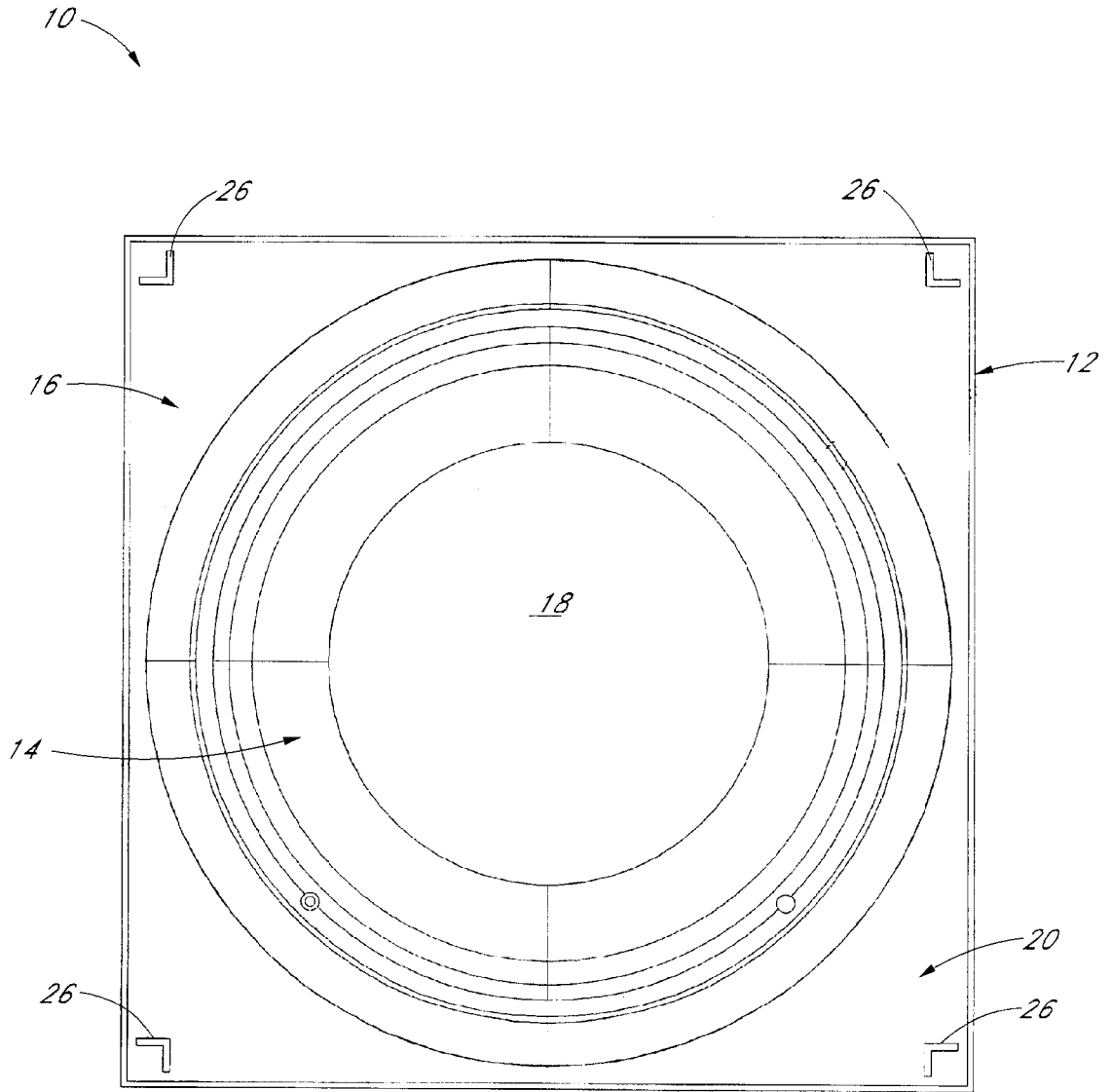

FIG. 4

5/22

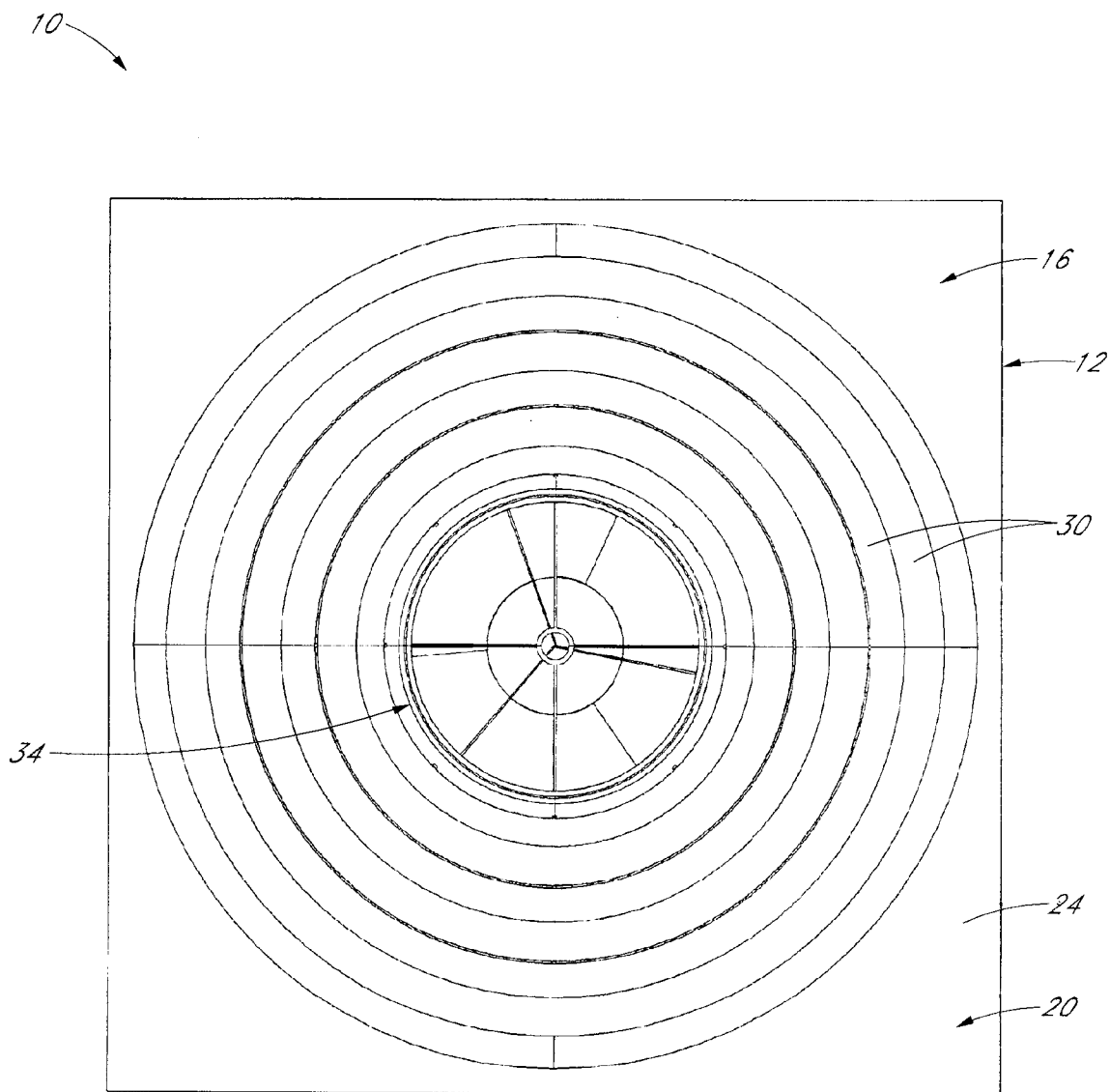

FIG. 5

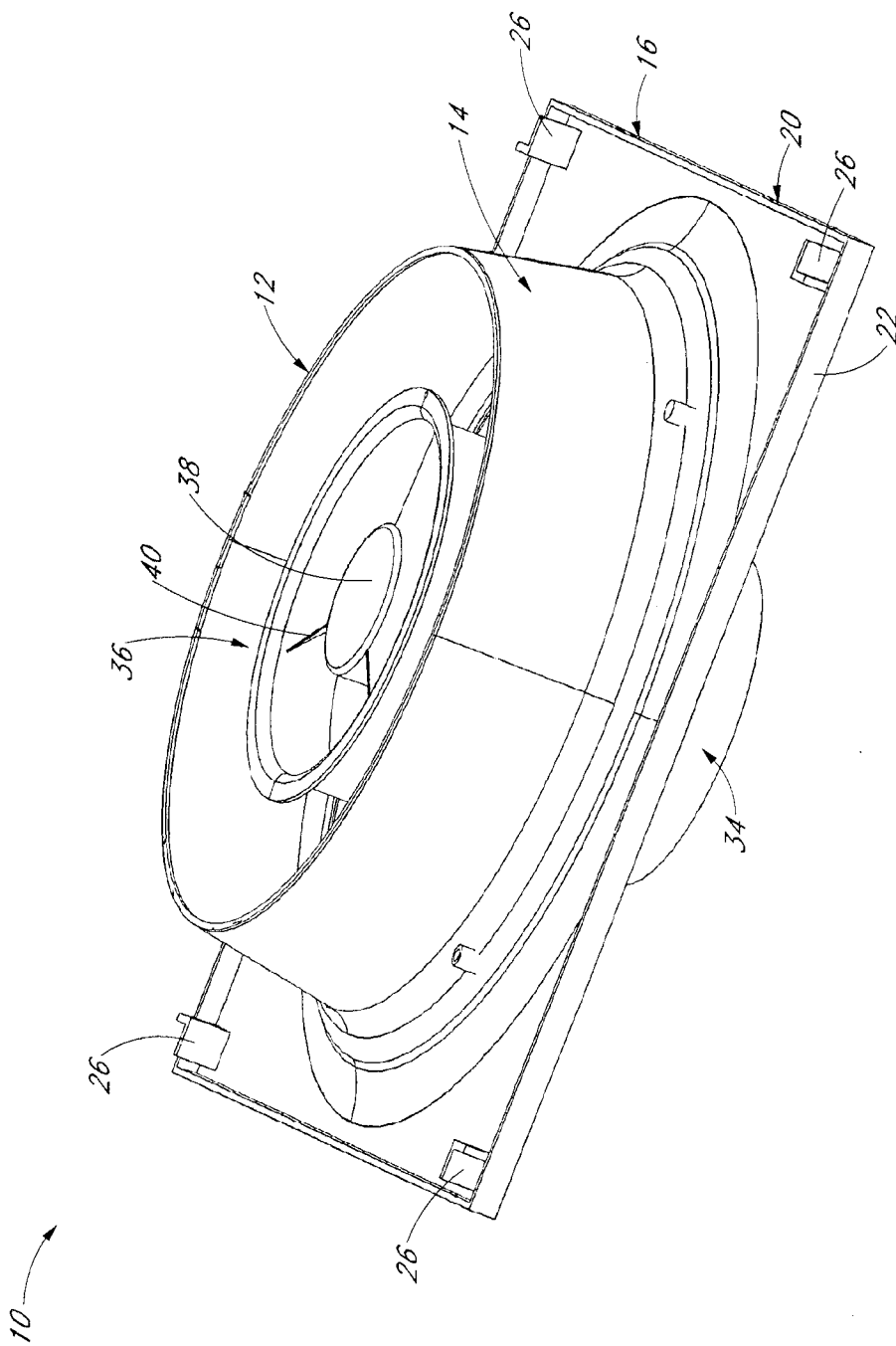

FIG. 6

7/22

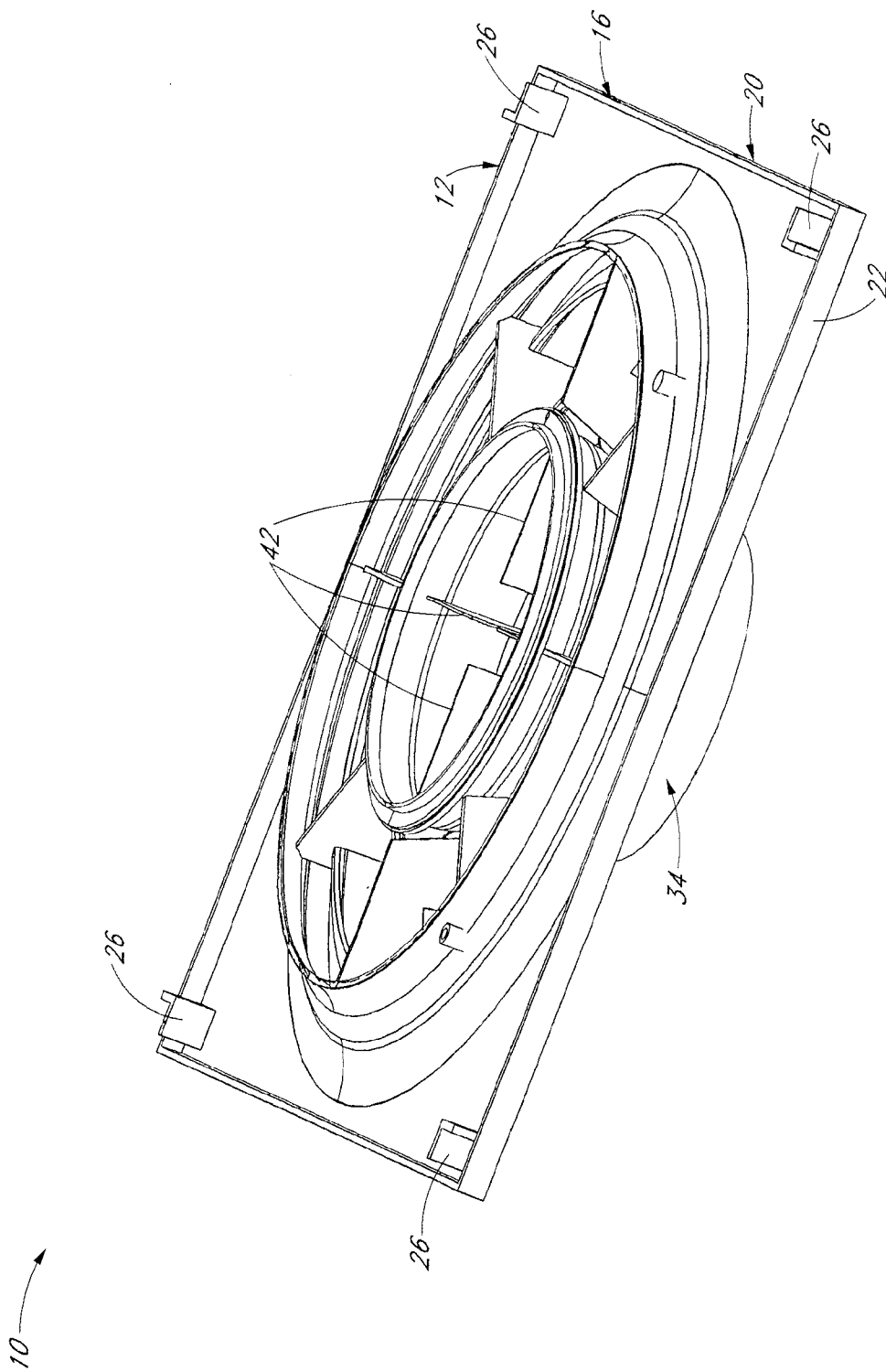

FIG. 7

8/22

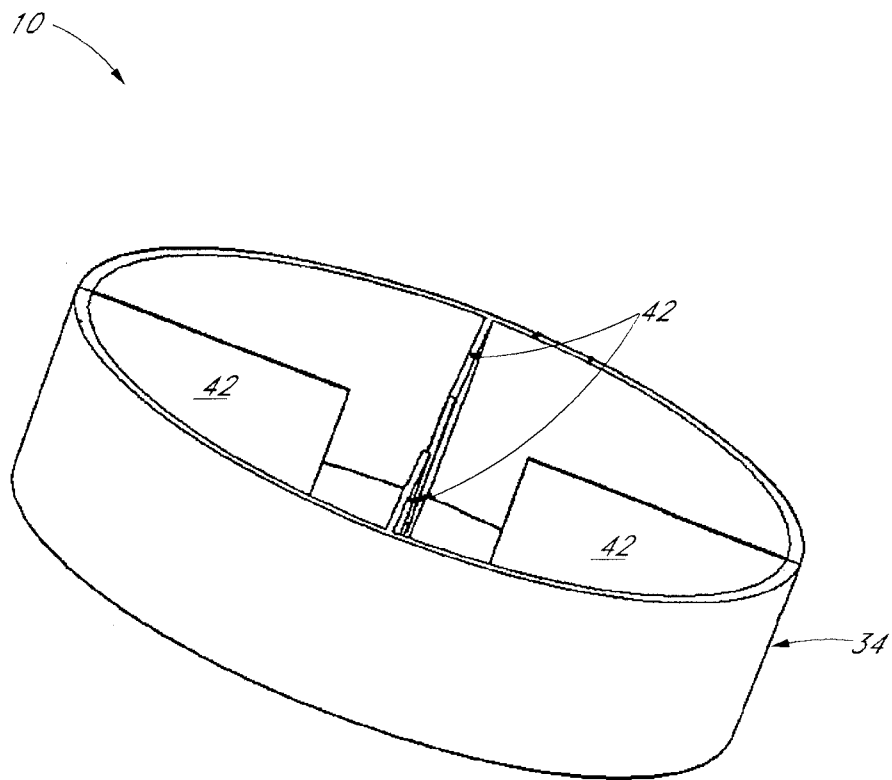
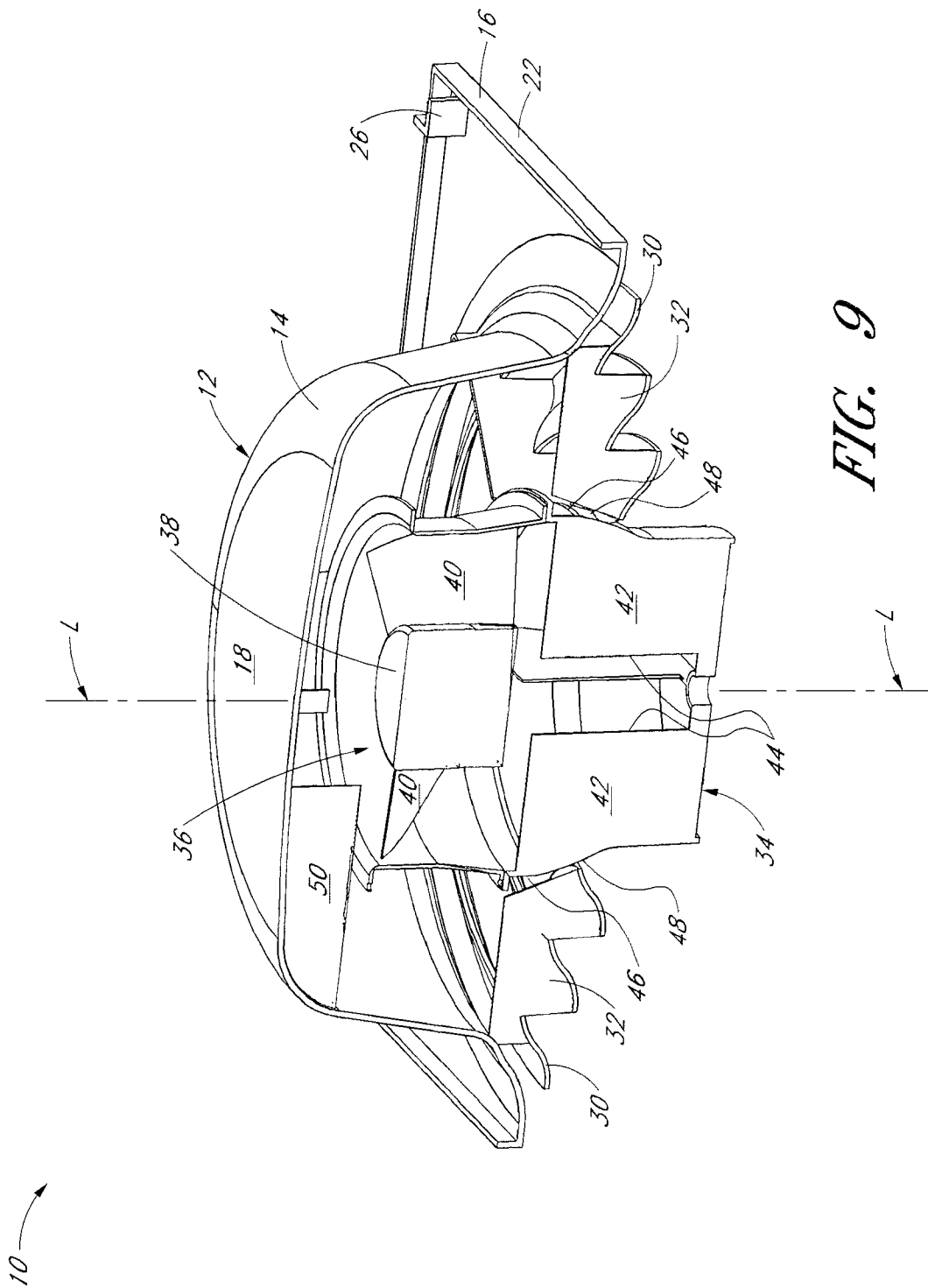

FIG. 8

9/22



10/22

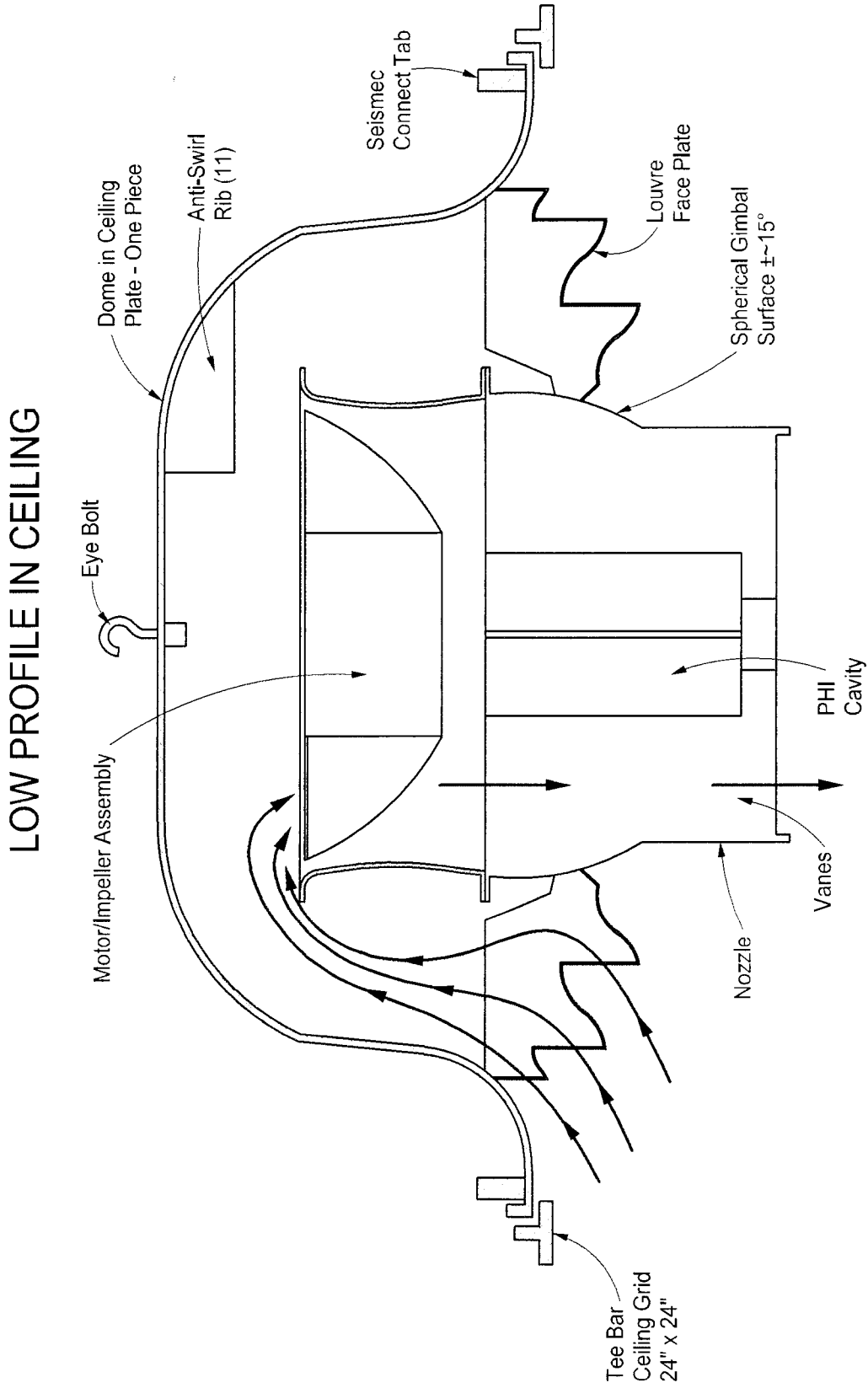

FIG. 10

11/22

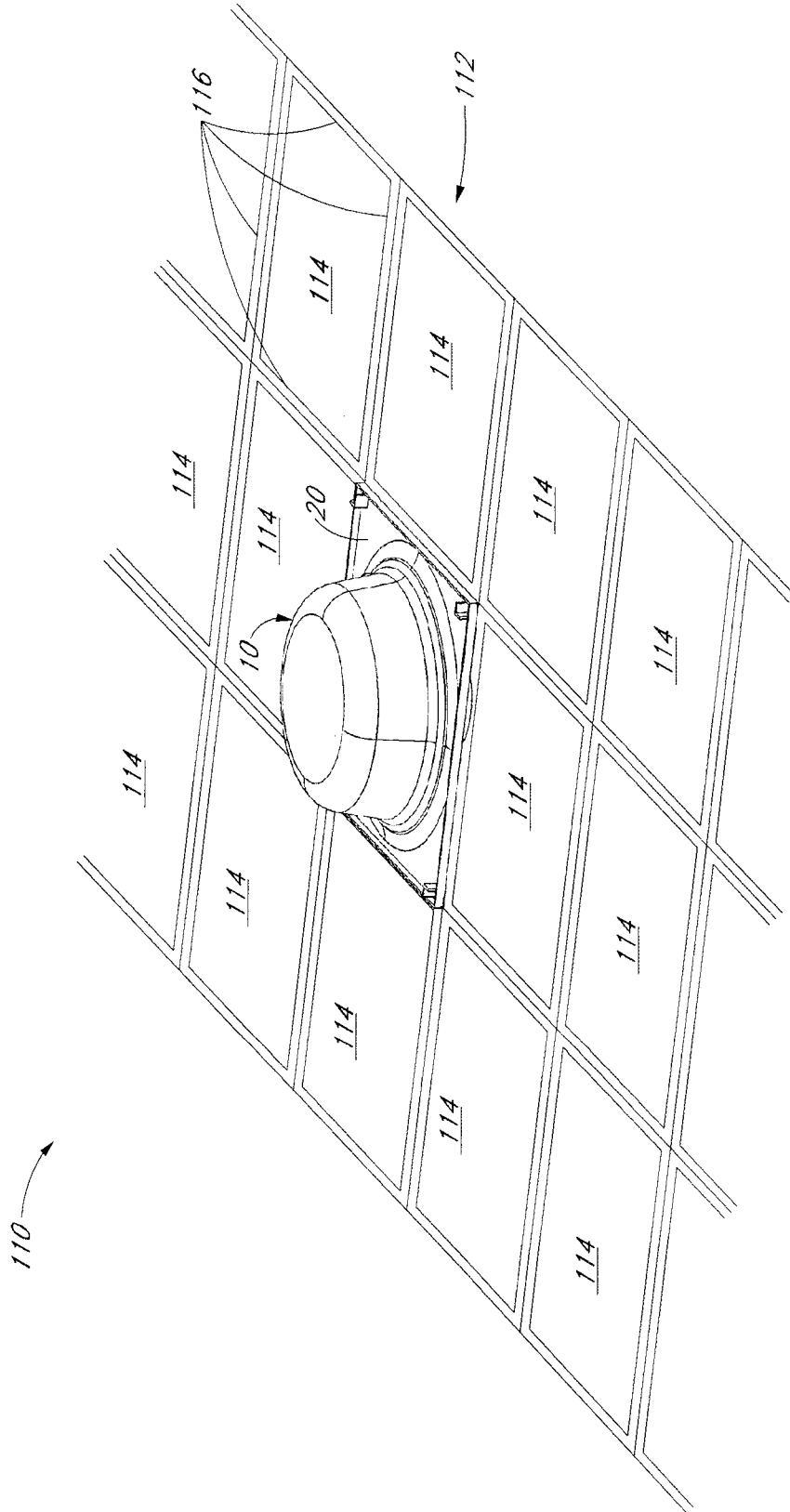

FIG. 11

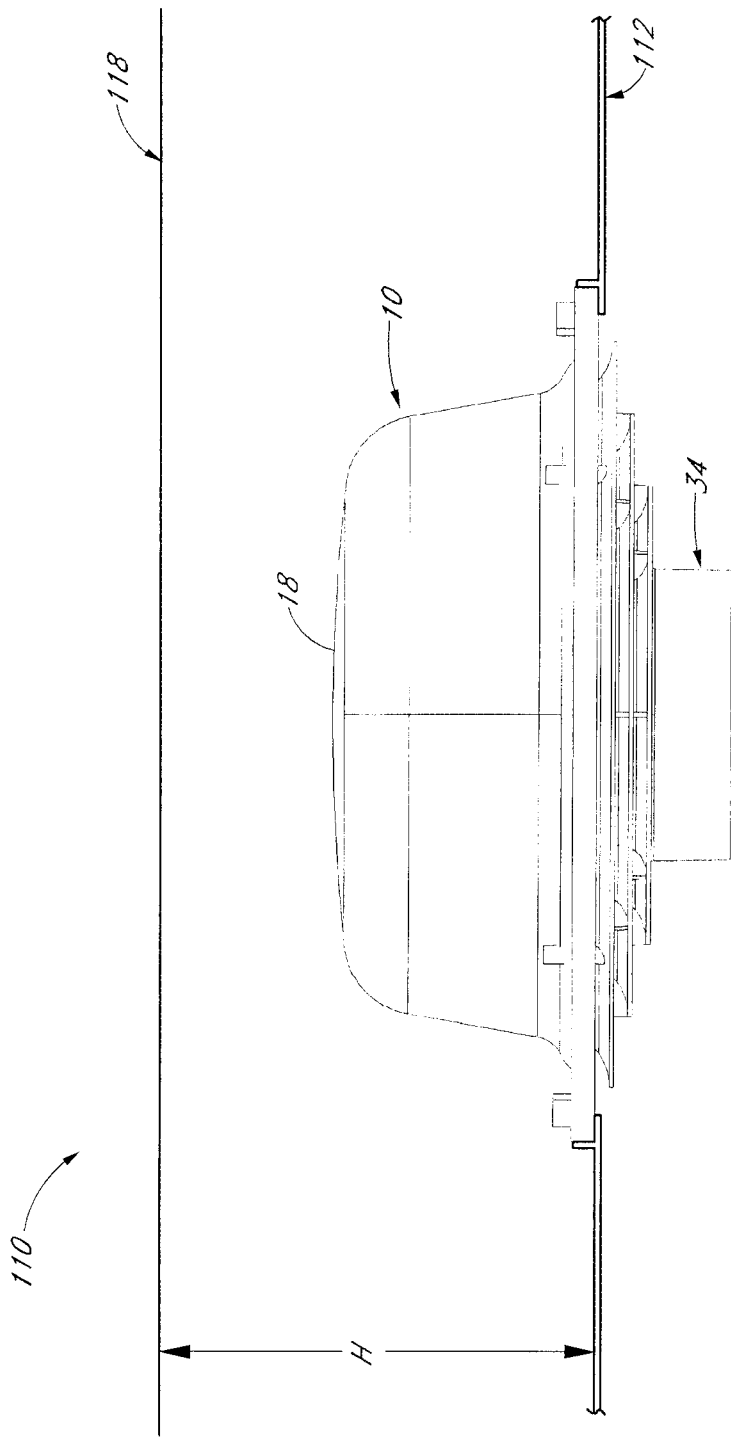

FIG. 12

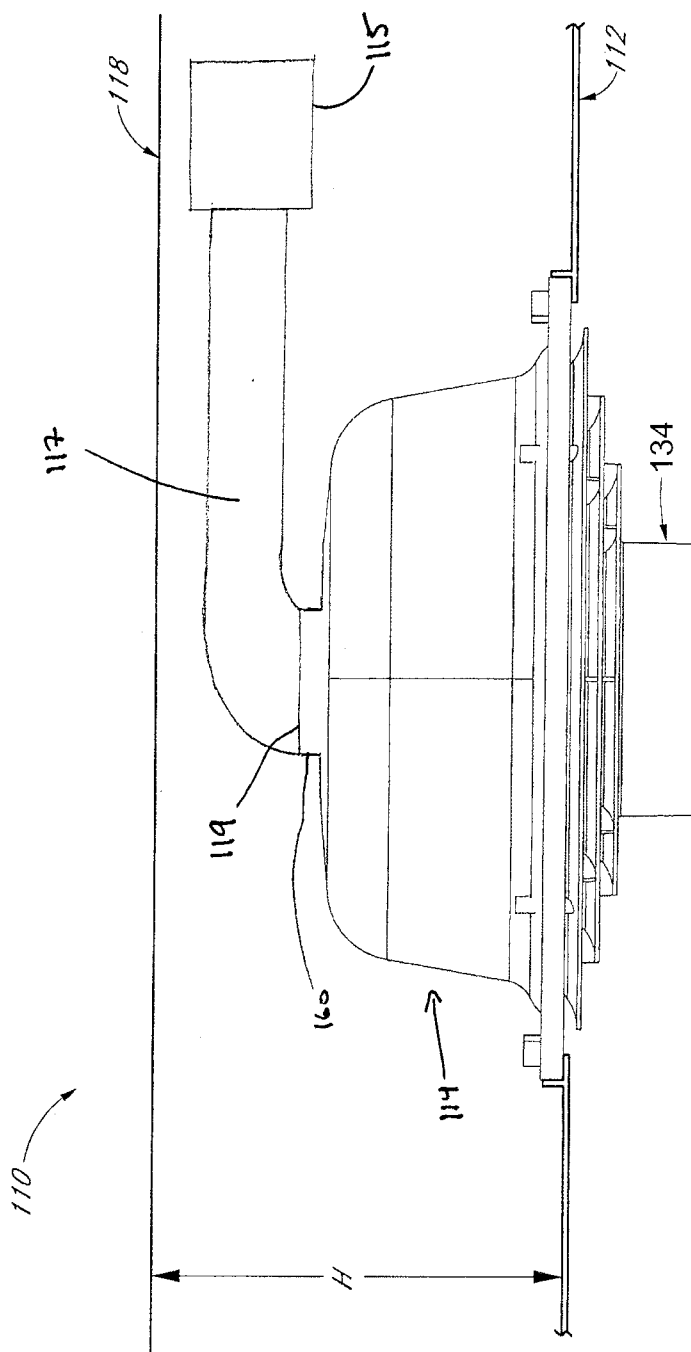

FIG. 13

14/22

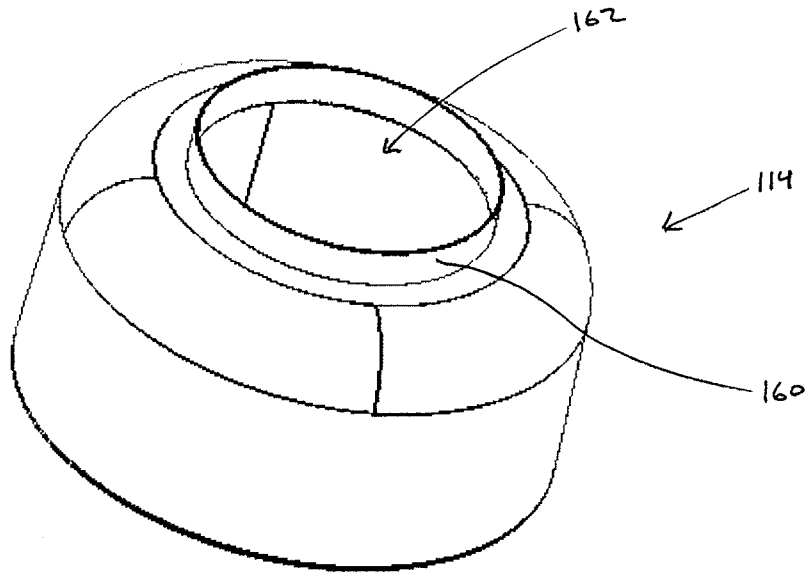

FIGURE 14

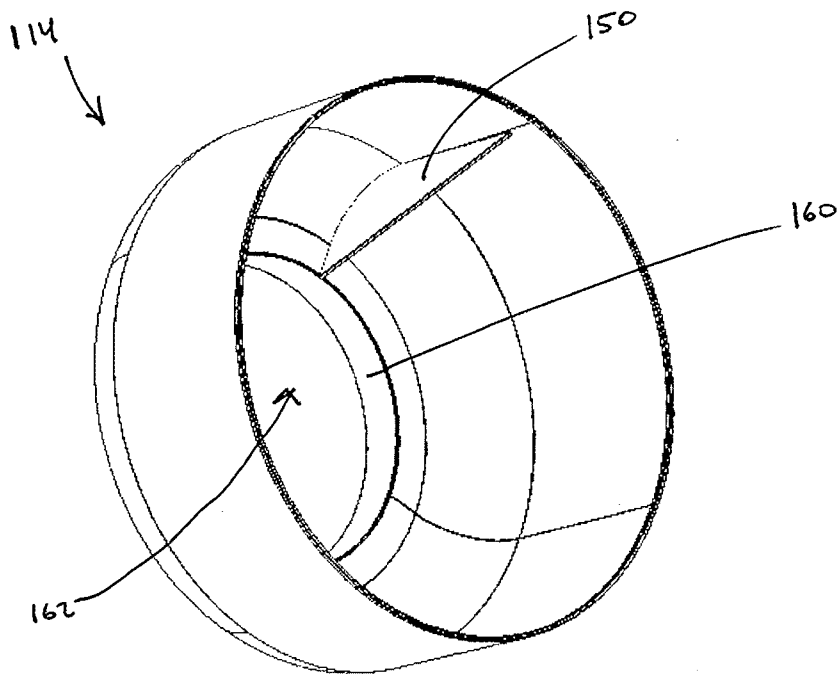

FIGURE 15

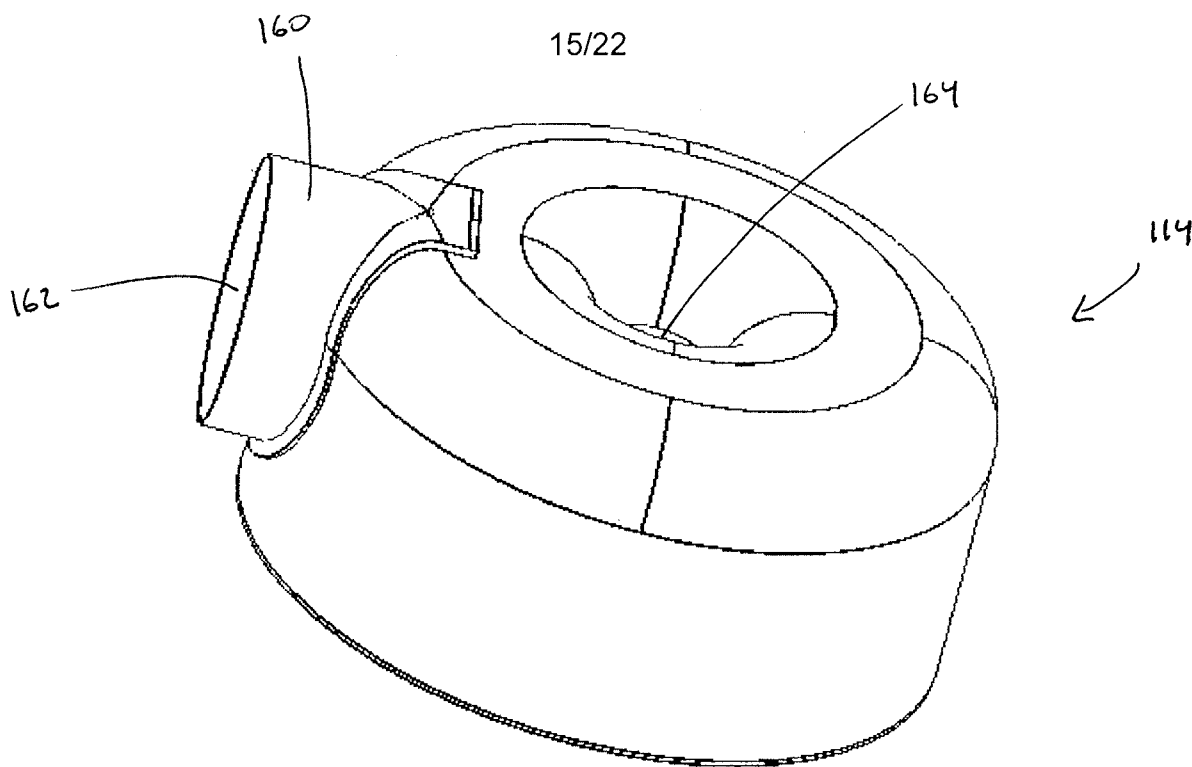

FIGURE 16

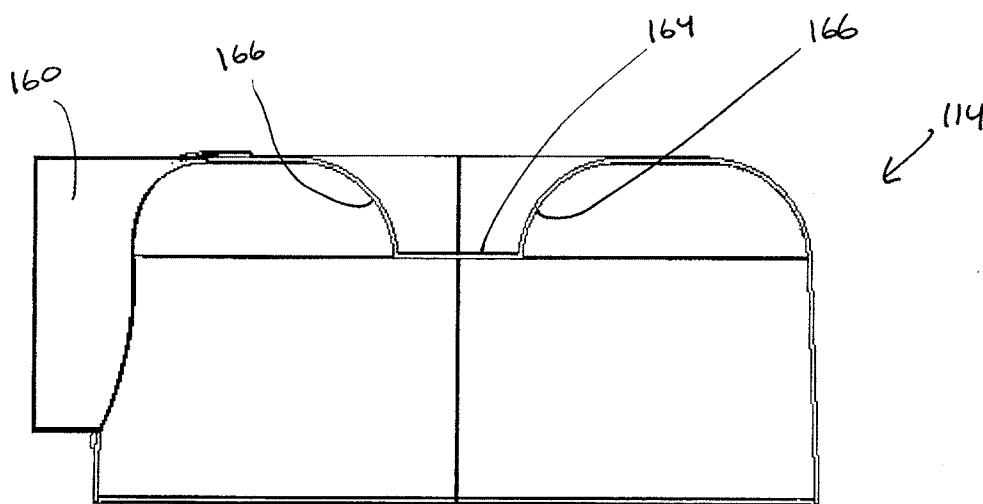

FIGURE 17

16/22

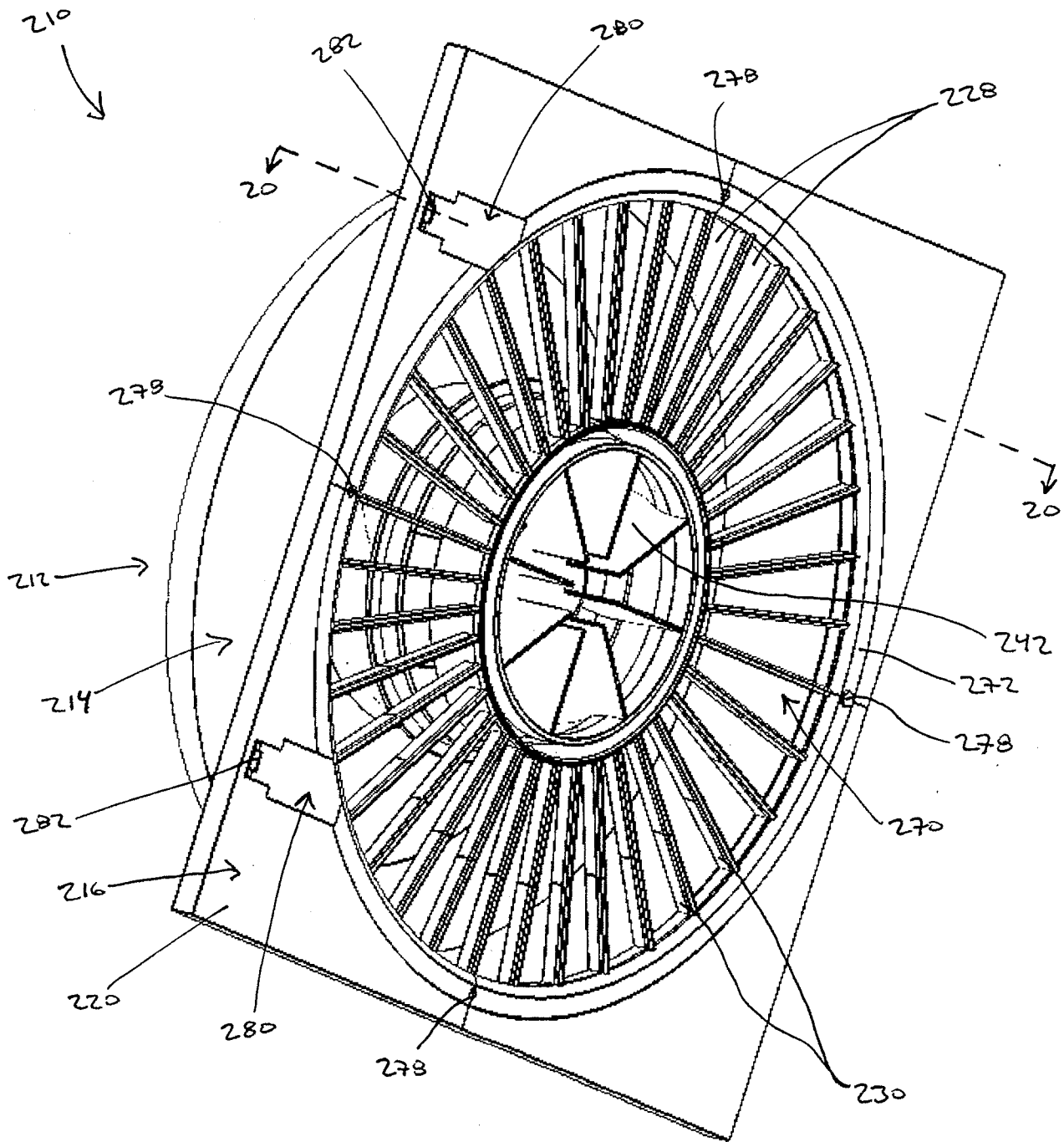

FIGURE 18

17/22

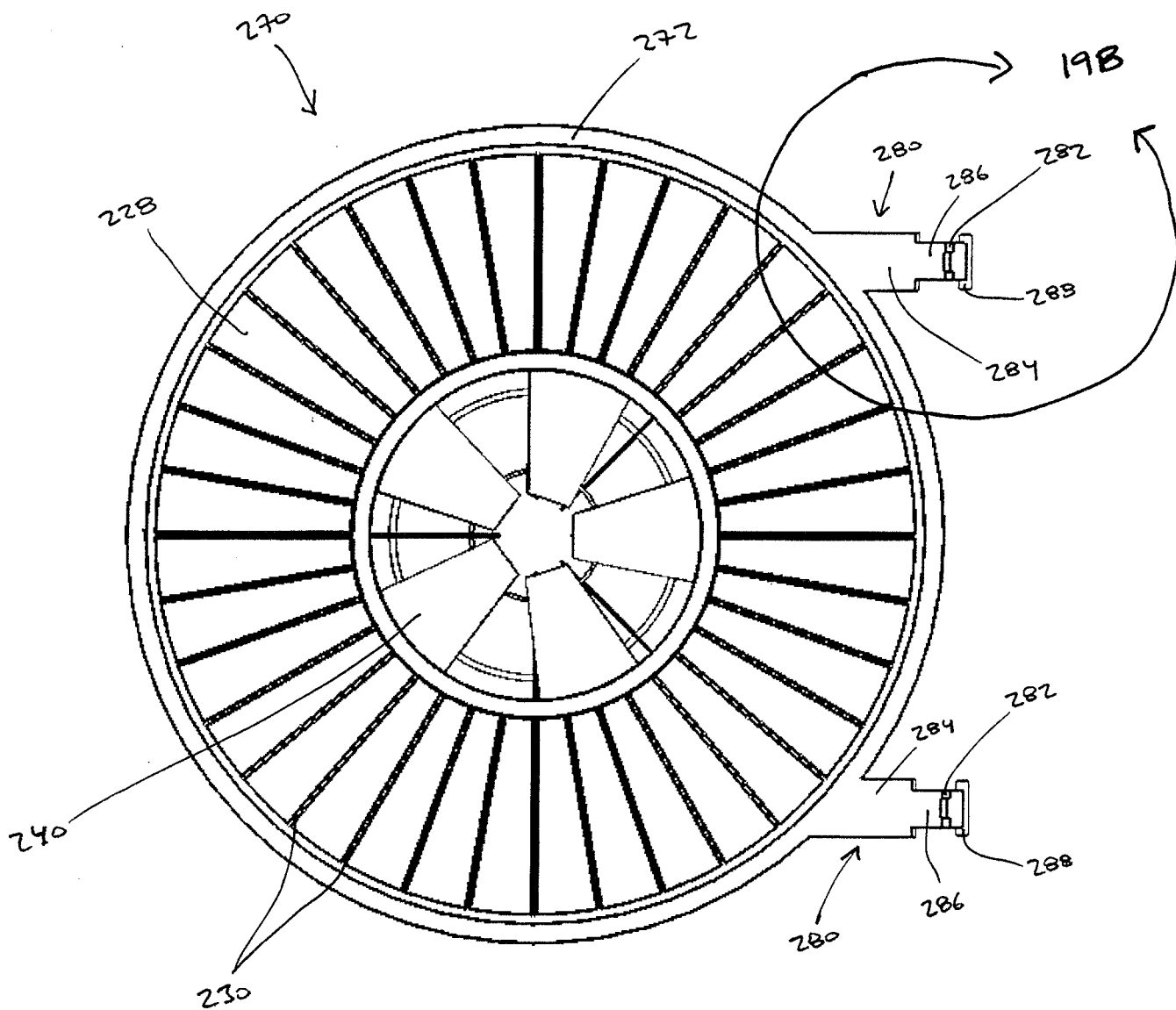

FIGURE 19A

18/22

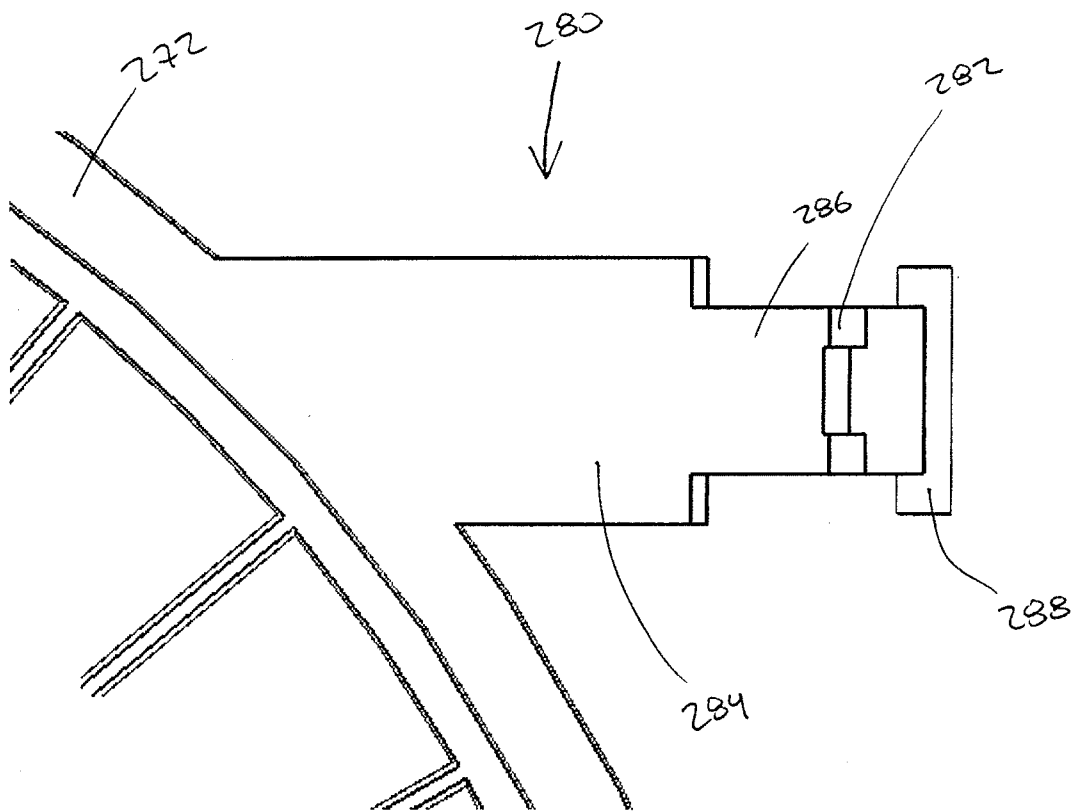

FIGURE 19B

20/22

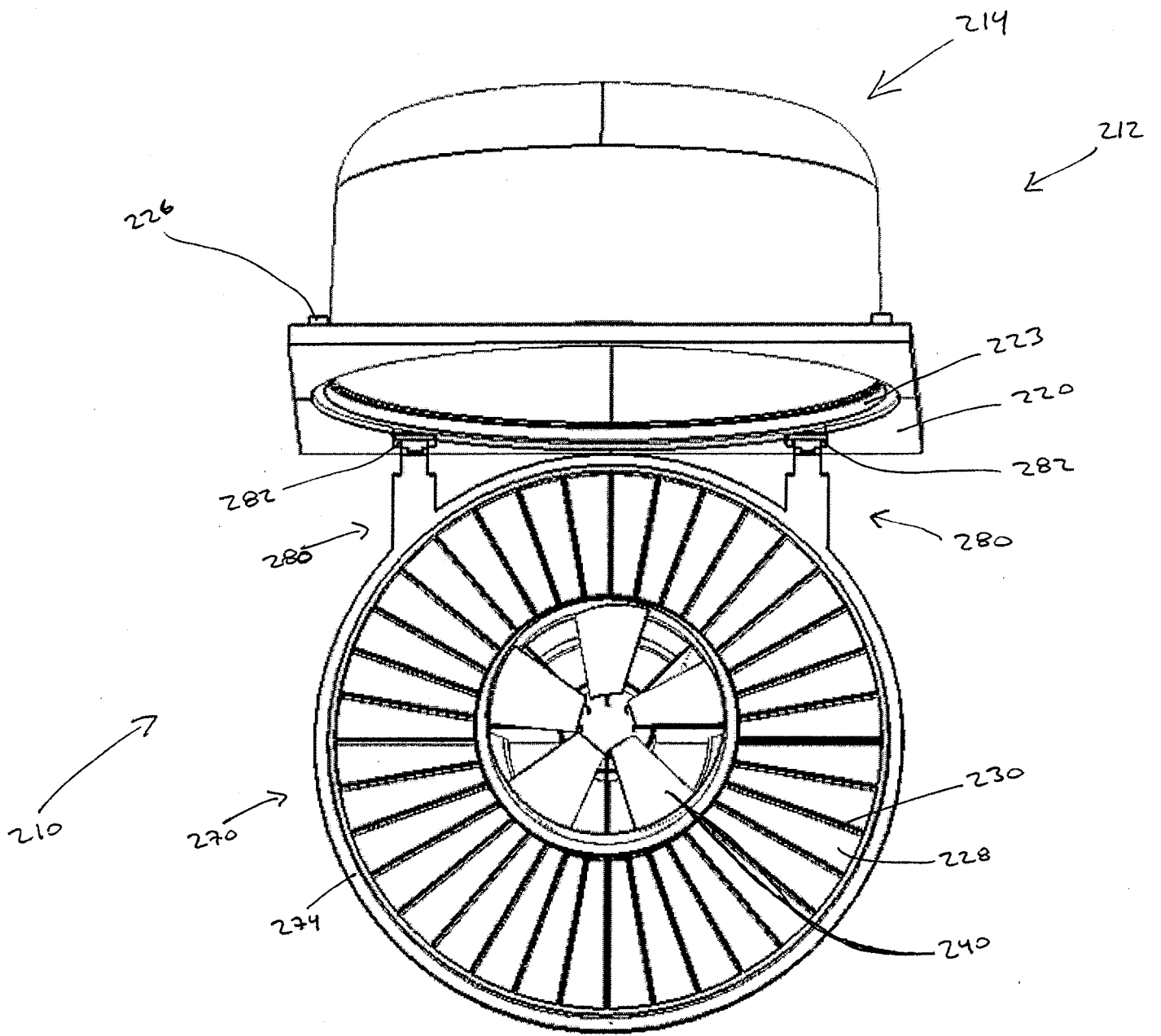

FIGURE 21

21/22

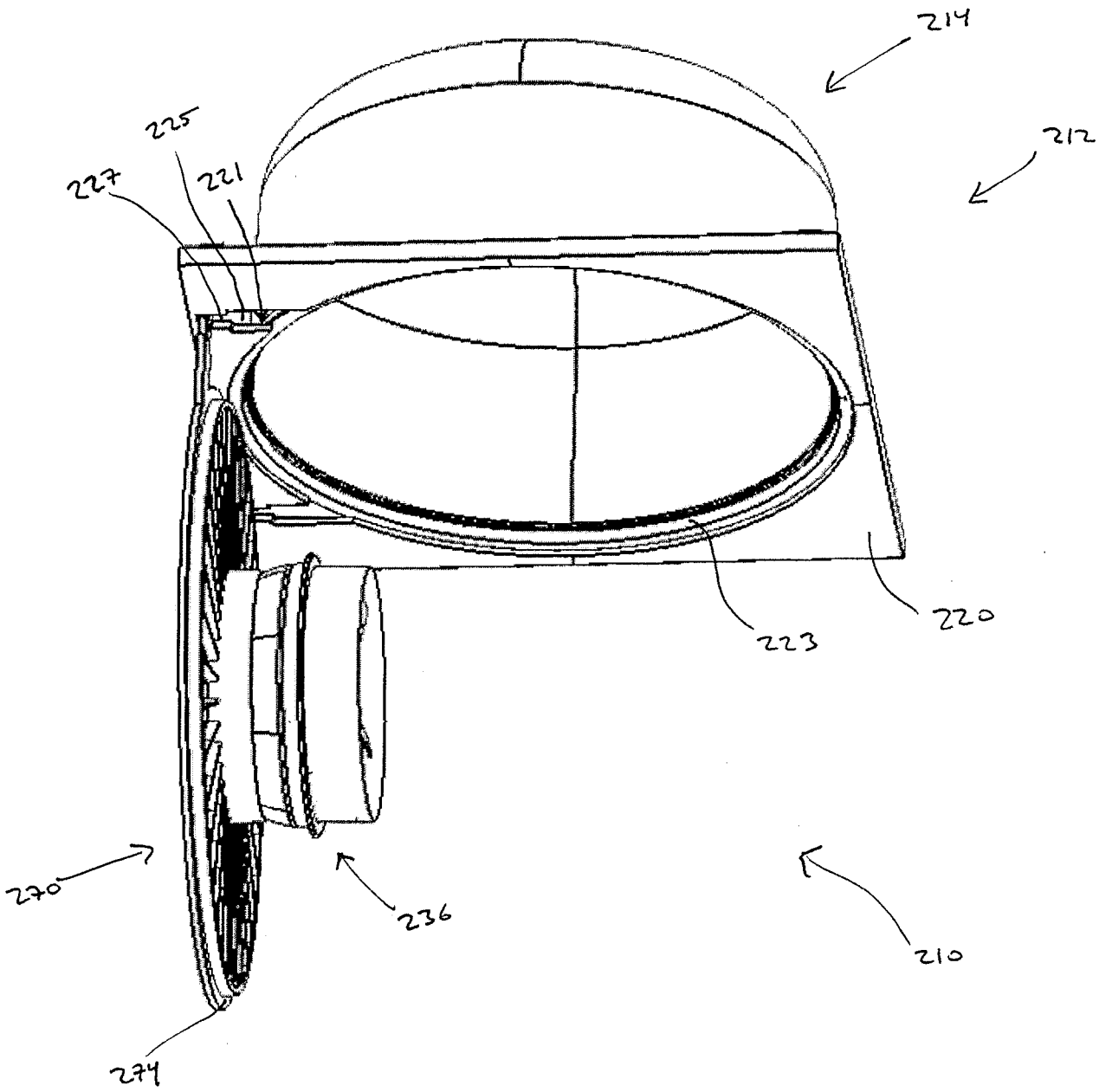

FIGURE 22

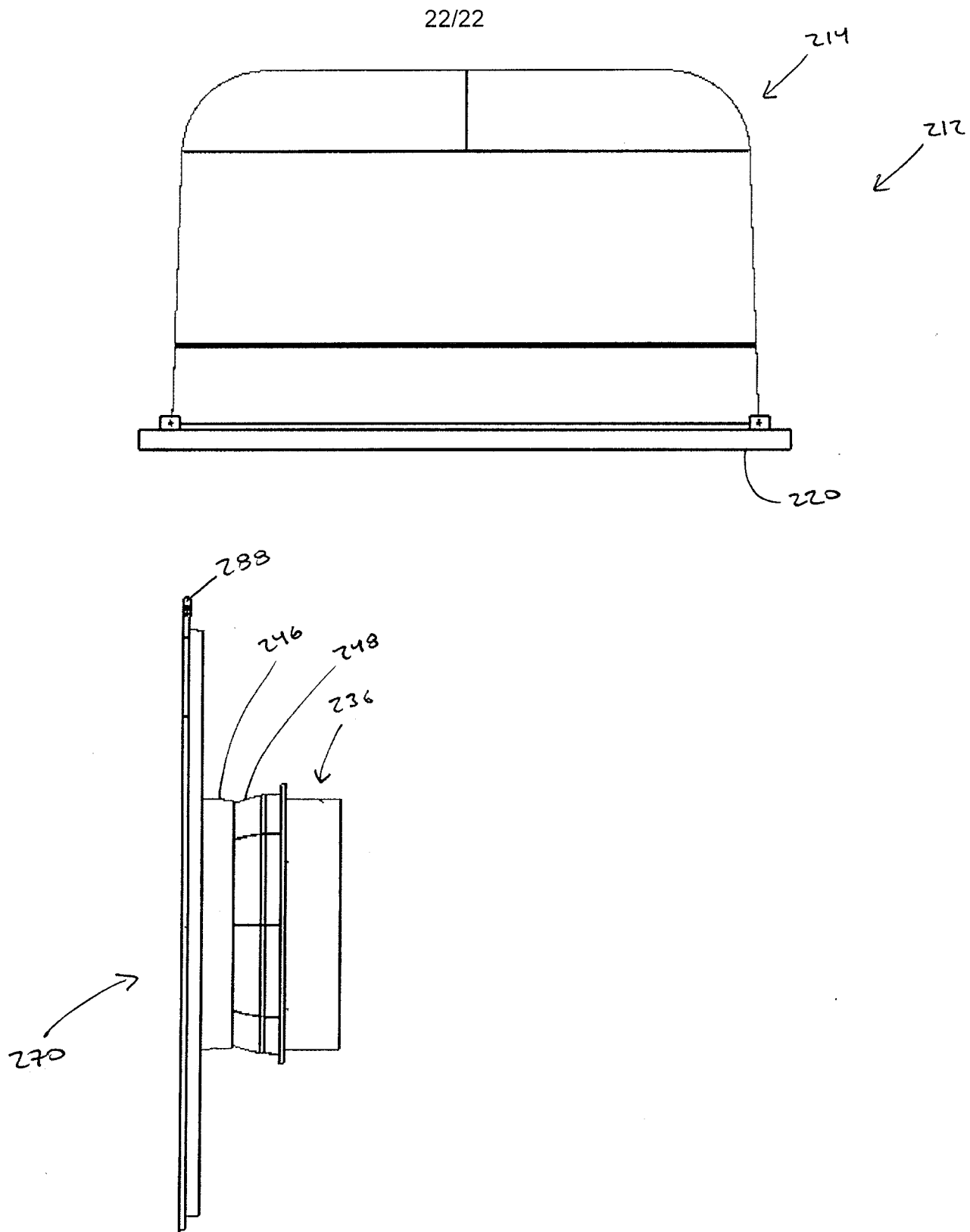

FIGURE 23

