



US00D995377S

(12) **United States Design Patent**  
**Grand**

(10) **Patent No.:** **US D995,377 S**

(45) **Date of Patent:** **\*\* Aug. 15, 2023**

- (54) **FRONT BUMPER**
- (71) Applicant: **Jaguar Land Rover Limited**, Coventry (GB)
- (72) Inventor: **Simon Grand**, Whitley Coventry (GB)
- (73) Assignee: **Jaguar Land Rover Limited**, Whitley Coventry (GB)
- (\*\*) Term: **15 Years**
- (21) Appl. No.: **29/834,257**
- (22) Filed: **Apr. 11, 2022**

D627,278 S \* 11/2010 Komuro ..... D12/169  
 D629,341 S \* 12/2010 Choi ..... D12/169  
 8,608,214 B2 \* 12/2013 Wallace ..... B60R 19/50  
 293/155  
 D711,793 S \* 8/2014 Nagasaka ..... D12/169  
 (Continued)

*Primary Examiner* — Richard E Chilcot  
 (74) *Attorney, Agent, or Firm* — Wood Herron & Evans LLP

(57) **CLAIM**

The ornamental design for a front bumper, as shown and described.

**DESCRIPTION**

FIG. 1 is a front left elevated perspective view of a front bumper according to the present invention.  
 FIG. 2 is a front left perspective view thereof.  
 FIG. 3 is a rear right elevated perspective view thereof.  
 FIG. 4 is a rear right perspective view thereof.  
 FIG. 5 is a front view thereof.  
 FIG. 6 is a rear view thereof.  
 FIG. 7 is a left side view thereof.  
 FIG. 8 is a right side view thereof.  
 FIG. 9 is a top view thereof.  
 FIG. 10 is a bottom view thereof; and,  
 FIG. 11 is another front view of the front bumper shown in FIGS. 1-10, but with the front bumper mounted on a vehicle, and the rest of the vehicle shown in de-emphasized and half-tone portions to illustrate environmental structure. These portions form no part of the claimed design. More particularly, in FIG. 11, the inventive front bumper is shown within the outer broken line, and the elements shown outside the outer broken line form no part of the claimed invention, but are instead included to show environmental structure. The outer broken line forms an unclaimed boundary of the design. The smaller internal broken lines also serve as unclaimed boundaries of the claimed design, and form no part thereof.

**Related U.S. Application Data**

- (62) Division of application No. 29/656,363, filed on Jul. 12, 2018, now Pat. No. Des. 950,435.

**Foreign Application Priority Data**

- Jan. 12, 2018 (EM) ..... 004663839
- Apr. 25, 2018 (EM) ..... 005248622
- Jul. 5, 2018 (EM) ..... 005438009

(51) **LOC (14) Cl.** ..... **12-16**

(52) **U.S. Cl.**  
 USPC ..... **D12/169**  
 CPC ..... **B60R 19/02** (2013.01)

(58) **Field of Classification Search**

USPC ..... D12/86-98, 163-169, 190, 196  
 CPC ..... B60R 19/02; B60R 19/04; B62D 25/08  
 See application file for complete search history.

**References Cited**

**U.S. PATENT DOCUMENTS**

- D614,547 S \* 4/2010 Schell ..... D12/163
- D614,548 S \* 4/2010 Oya ..... D12/169
- D617,700 S \* 6/2010 Nishio ..... D12/169
- D624,470 S \* 9/2010 Takahashi ..... D12/169
- D626,472 S \* 11/2010 Loeb ..... D12/169
- D626,473 S \* 11/2010 Mueller ..... D12/169

**1 Claim, 11 Drawing Sheets**

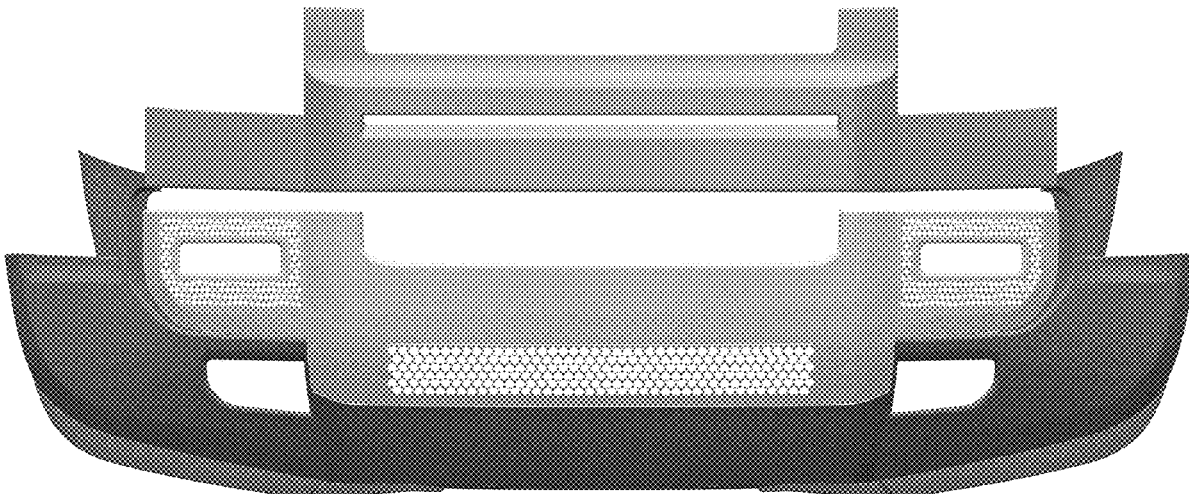

(56)

References Cited

U.S. PATENT DOCUMENTS

D711,794 S *	8/2014	Okamura	D12/169	D893,368 S *	8/2020	Oh	D12/169
D745,837 S *	12/2015	Smith	D12/169	D896,713 S *	9/2020	Choi	D12/169
D775,010 S *	12/2016	Kim	D12/169	D898,633 S *	10/2020	Patel	D12/169
9,688,227 B2 *	6/2017	Cepollaro	B60Q 1/20	D898,634 S *	10/2020	Patel	D12/169
D792,292 S *	7/2017	Spencer	D12/169	D900,678 S *	11/2020	Grand	D12/91
D800,615 S *	10/2017	Park	D12/169	D901,334 S *	11/2020	Grand	D12/91
D801,886 S *	11/2017	Toriyama	D12/169	D901,344 S *	11/2020	Kim	D12/169
D829,619 S *	10/2018	Kim	D12/169	D902,806 S *	11/2020	Oh	D12/169
D829,620 S *	10/2018	Lim	D12/169	D904,265 S *	12/2020	Battams	D12/196
D834,471 S *	11/2018	Hill	D12/169	D909,931 S *	2/2021	Toriyama	D12/169
D839,149 S *	1/2019	Wheel	D12/169	D910,505 S *	2/2021	Wheel	D12/169
D843,899 S *	3/2019	Nakajima	D12/169	D910,506 S *	2/2021	Wheel	D12/169
D844,509 S *	4/2019	Grewer	D12/169	D911,877 S *	3/2021	Grand	D12/91
D860,050 S *	9/2019	Grewer	D12/91	D913,158 S *	3/2021	Grand	D12/91
D860,886 S *	9/2019	Hong	D12/169	D915,958 S *	4/2021	Lee	D12/169
D861,551 S *	10/2019	Grand	D12/169	D917,353 S *	4/2021	Lee	D12/169
D862,316 S *	10/2019	Melikian	D12/169	D918,792 S *	5/2021	Koo	D12/169
D865,588 S *	11/2019	Hong	D12/169	D919,514 S *	5/2021	Trim	D12/169
D870,610 S *	12/2019	Tonello	D12/169	D922,277 S *	6/2021	Kim	D12/169
D871,280 S *	12/2019	Trim	D12/169	D922,278 S *	6/2021	Kim	D12/169
D874,363 S *	2/2020	Patel	D12/82	D931,771 S *	9/2021	Koyama	D12/169
D875,603 S *	2/2020	Grand	D12/91	D941,188 S *	1/2022	Grand	D12/92
D875,604 S *	2/2020	Grand	D12/91	D943,470 S *	2/2022	Trim	D12/169
D875,605 S *	2/2020	Grand	D12/91	D950,435 S *	5/2022	Grand	B60R 19/02
D875,606 S *	2/2020	Grand	D12/91				D12/169
D886,692 S *	6/2020	Yokoi	D12/169	D958,001 S *	7/2022	Grand	D12/91
D890,043 S *	7/2020	Choi	D12/169	D958,002 S *	7/2022	Grand	D12/91
D892,687 S *	8/2020	Kim	D12/169	2008/0079271 A1 *	4/2008	Maruko	B60R 19/52
D892,688 S *	8/2020	Oh	D12/169				293/102
D893,367 S *	8/2020	Kim	D12/169	2009/0243340 A1 *	10/2009	Goldsberry	B60R 19/50
							296/191

\* cited by examiner

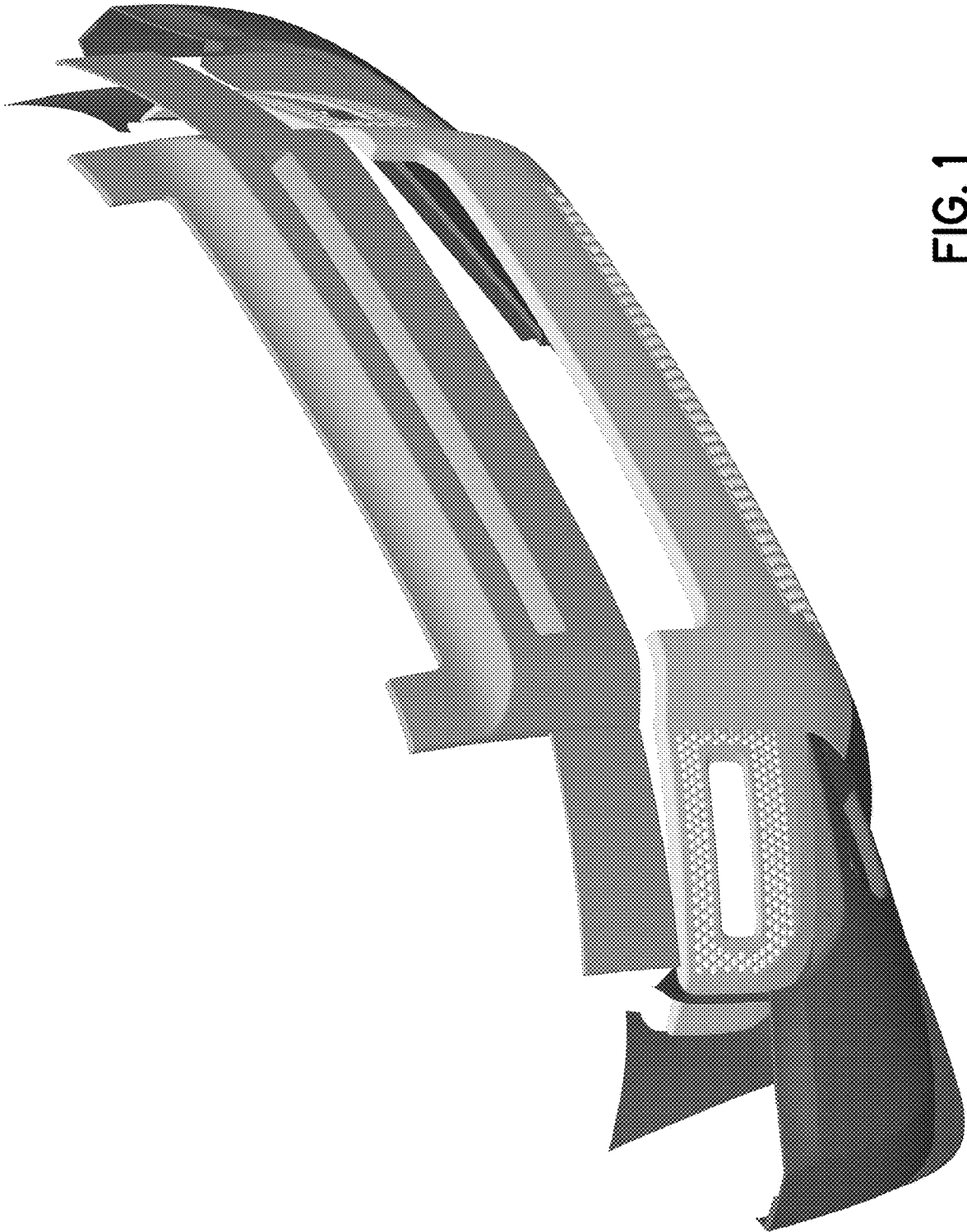

FIG. 1

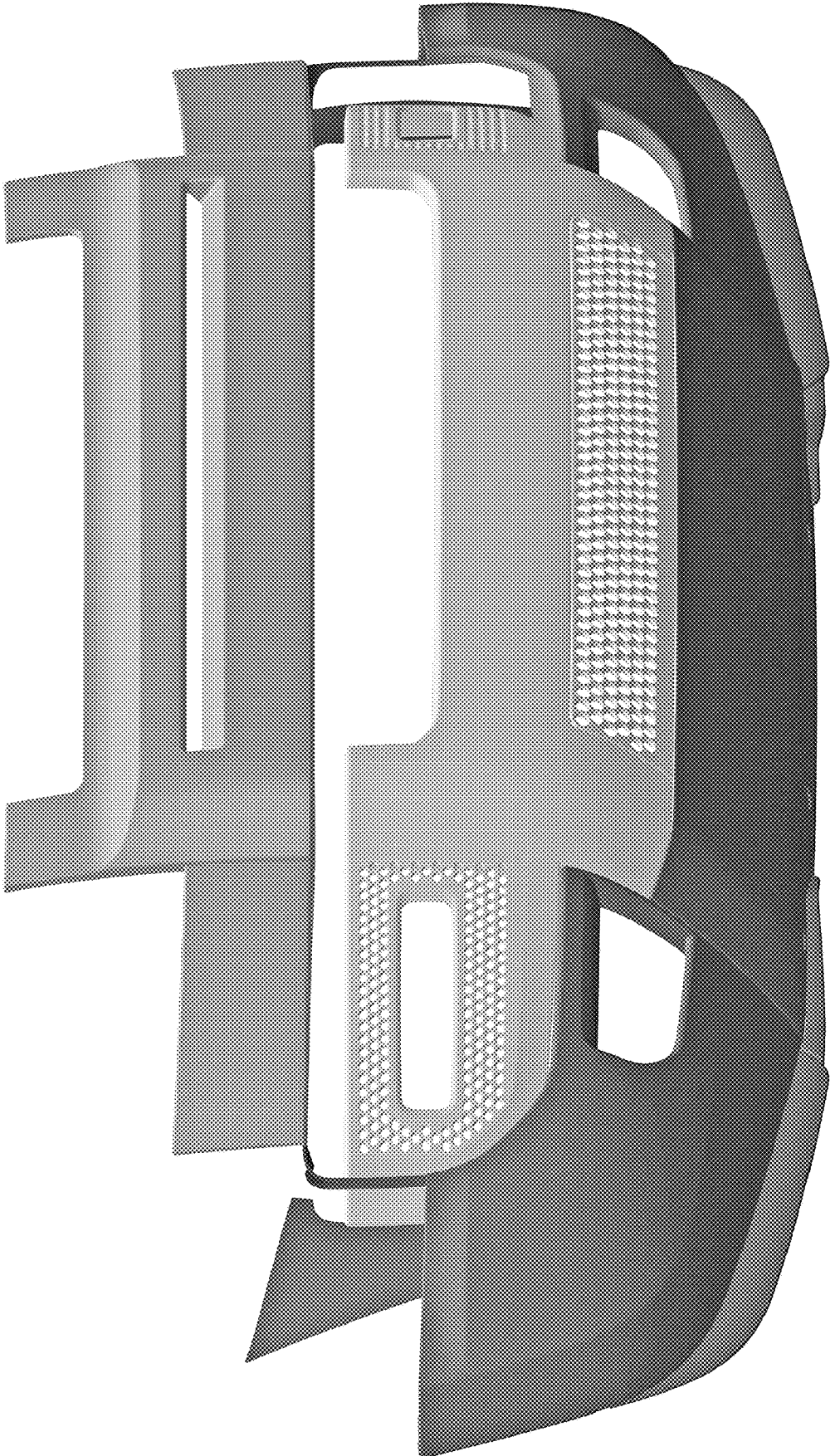

FIG. 2

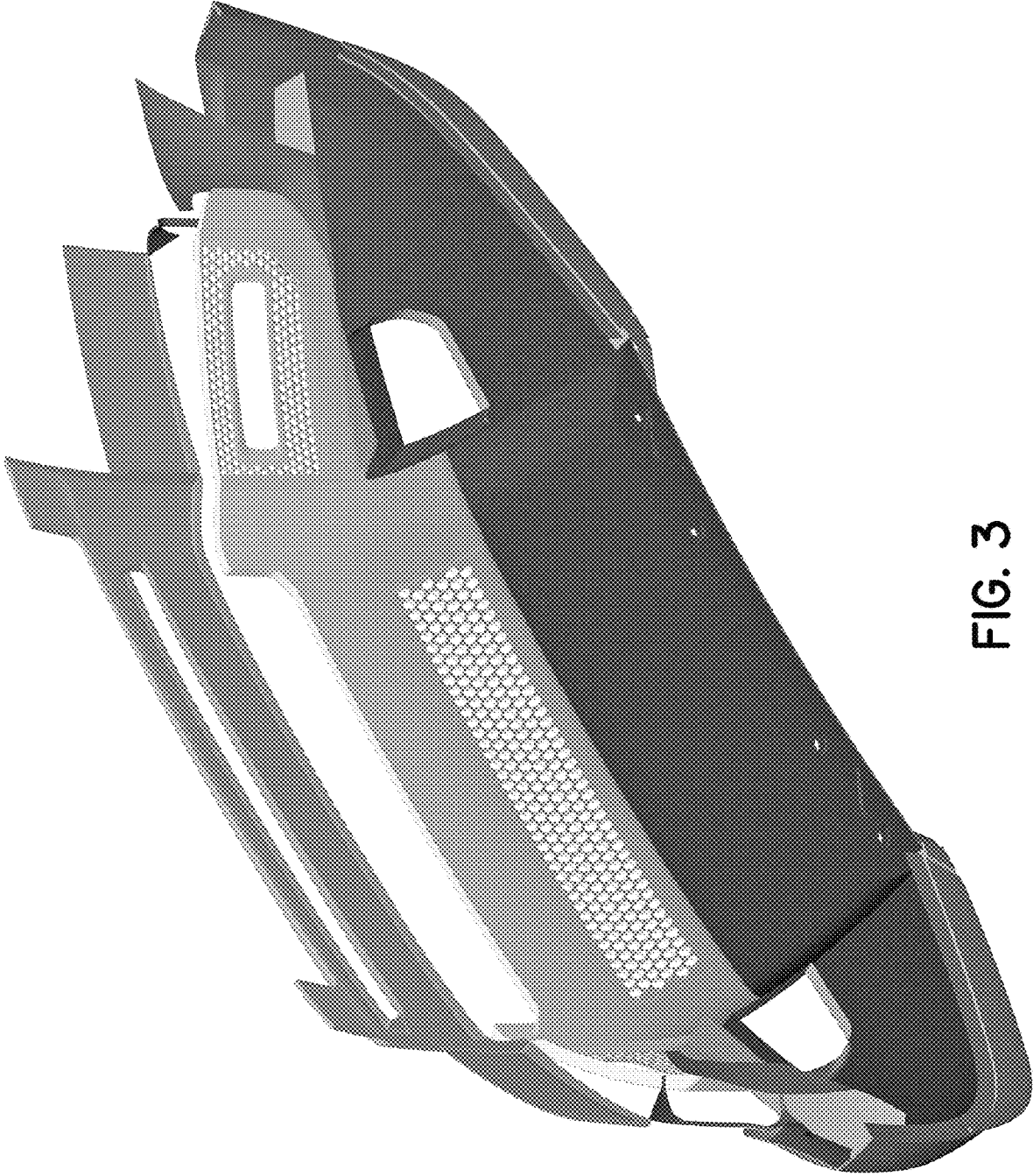

FIG. 3

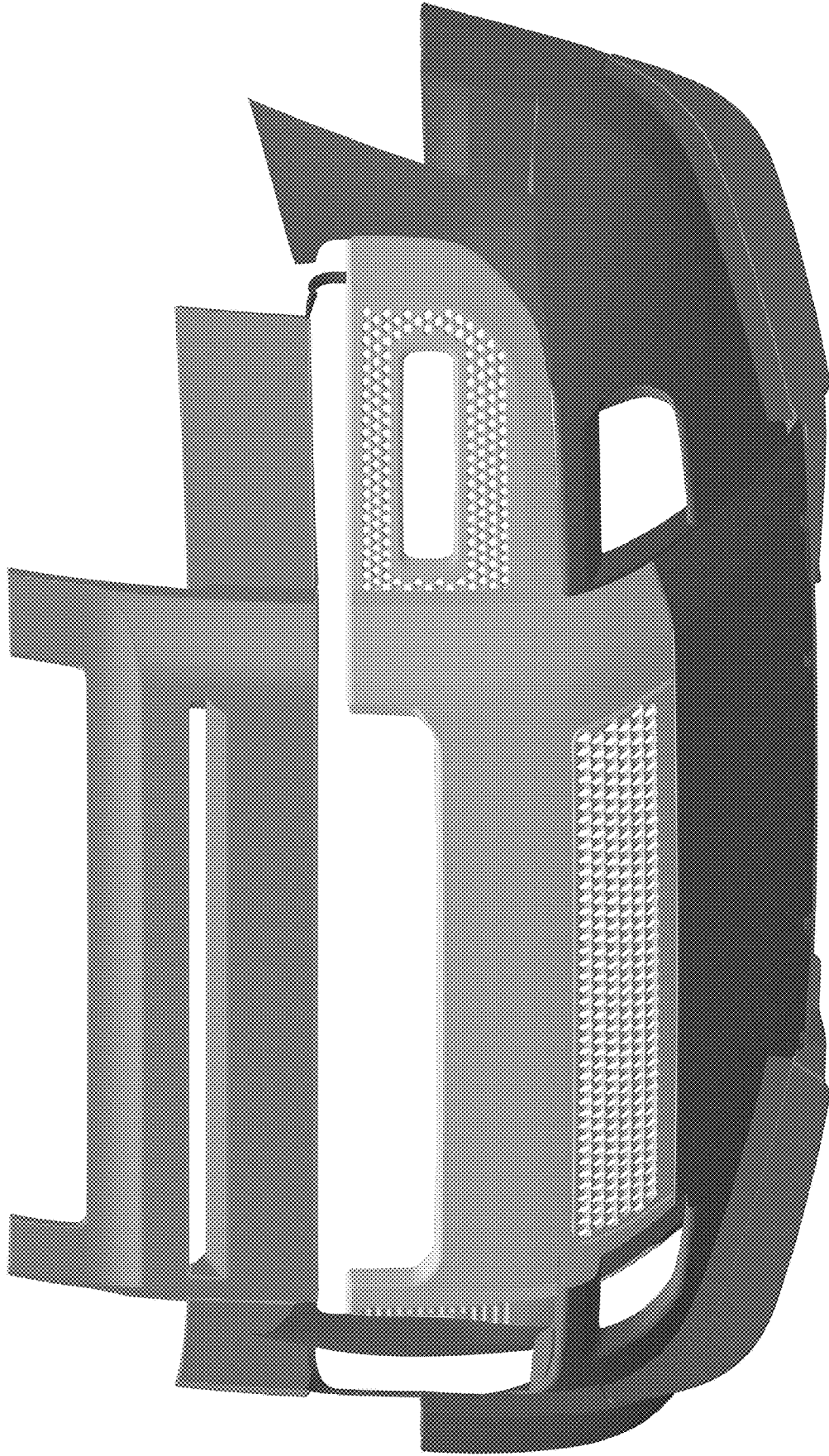

FIG. 4

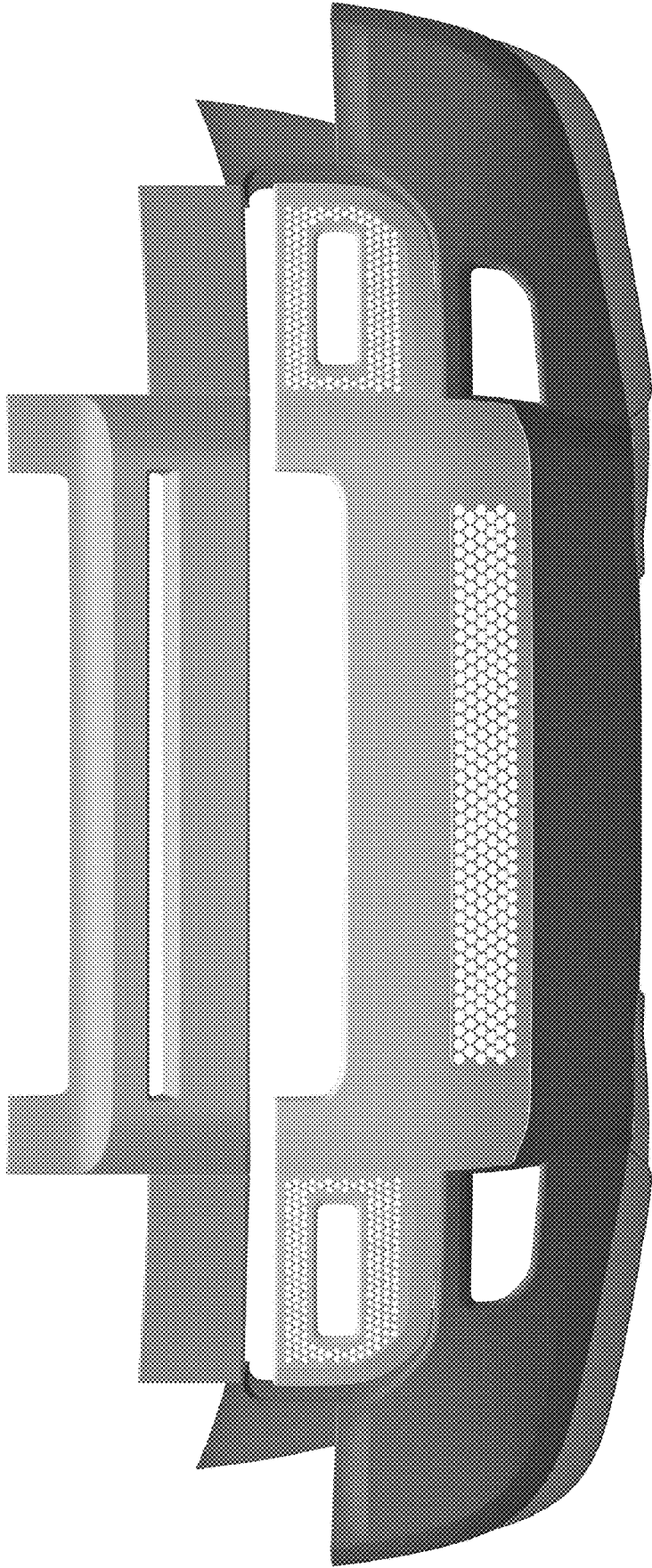

FIG. 5

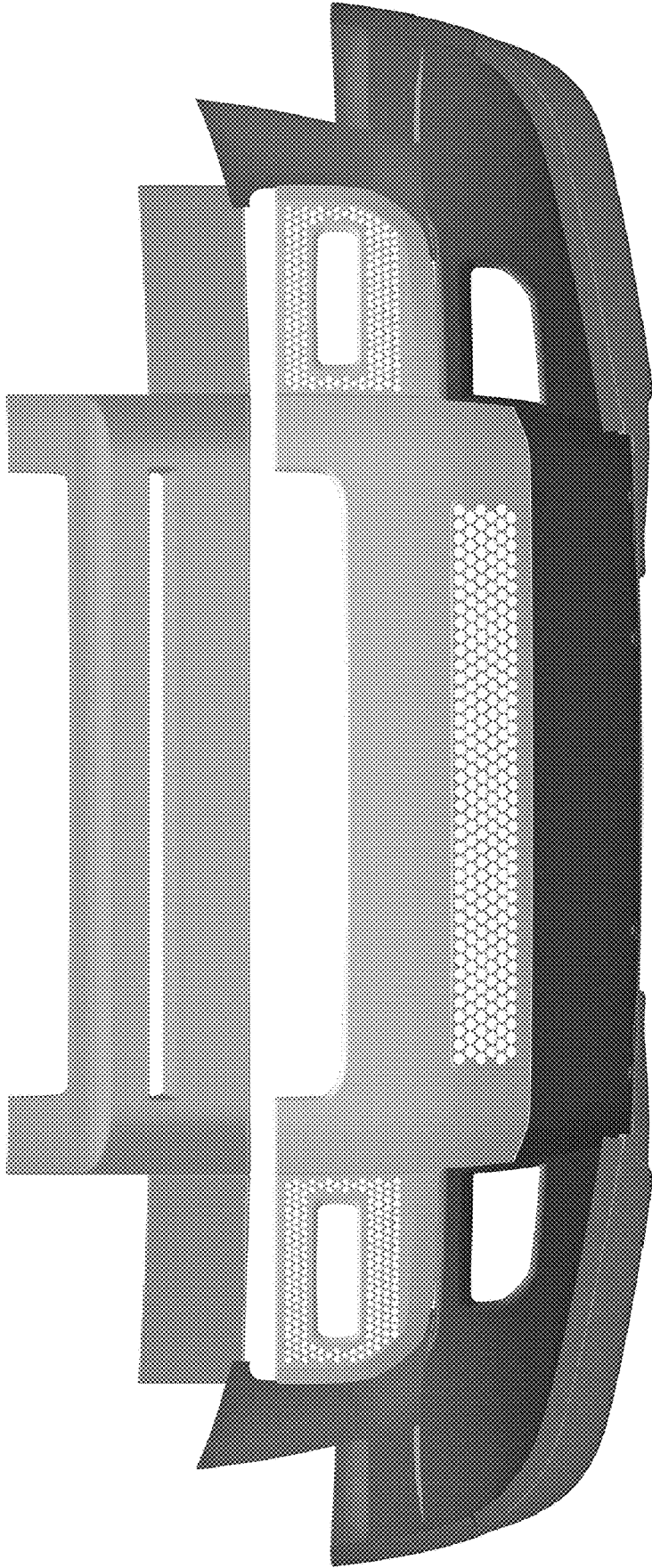

FIG. 6



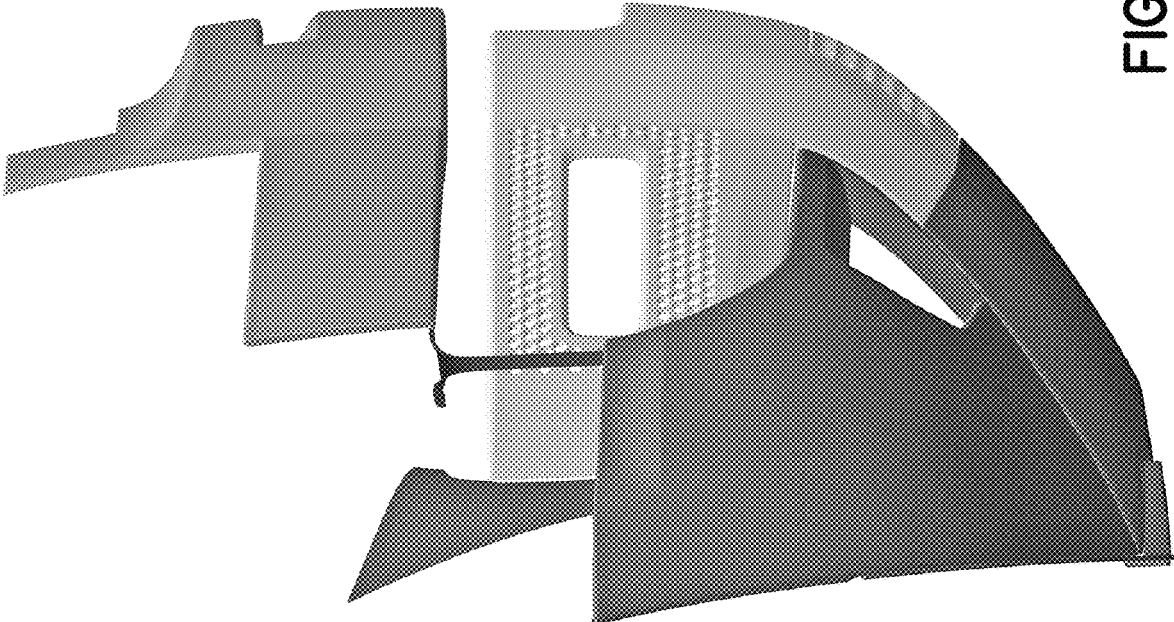

FIG. 7

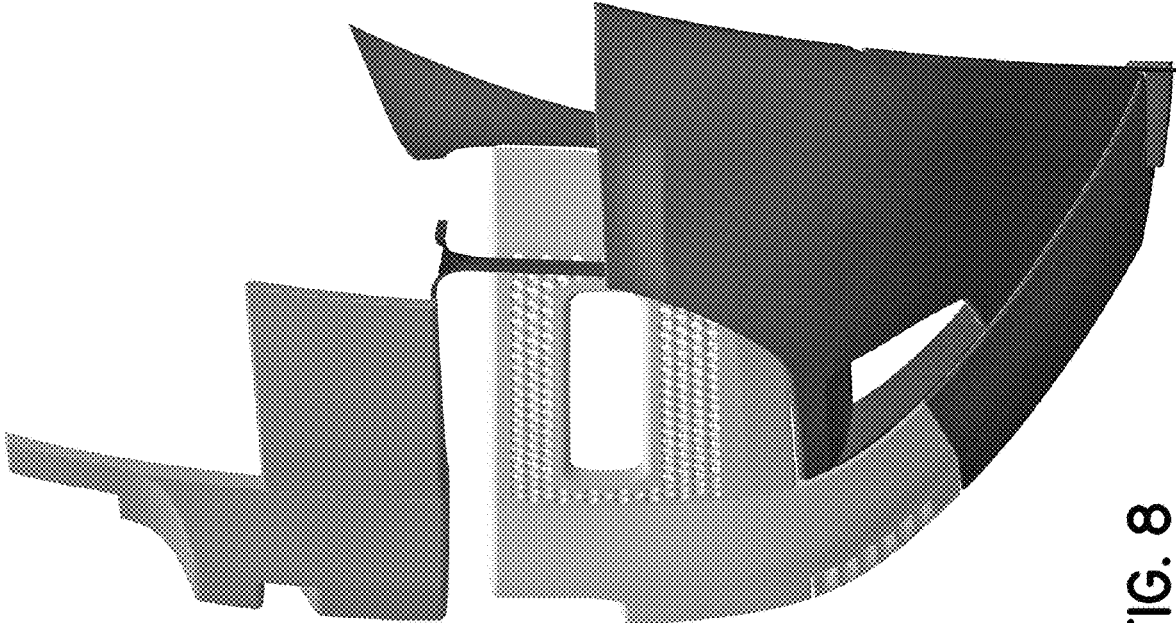

FIG. 8

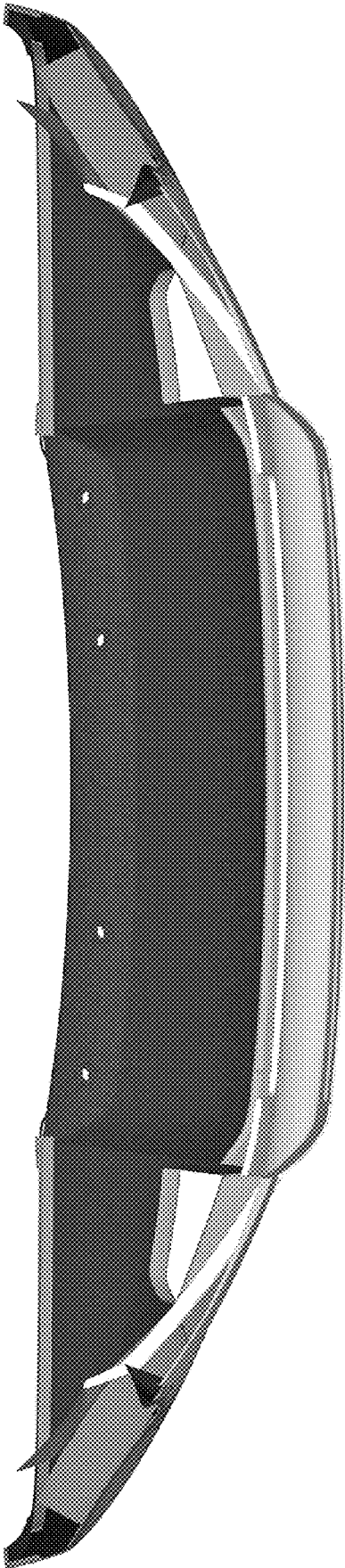

FIG. 9

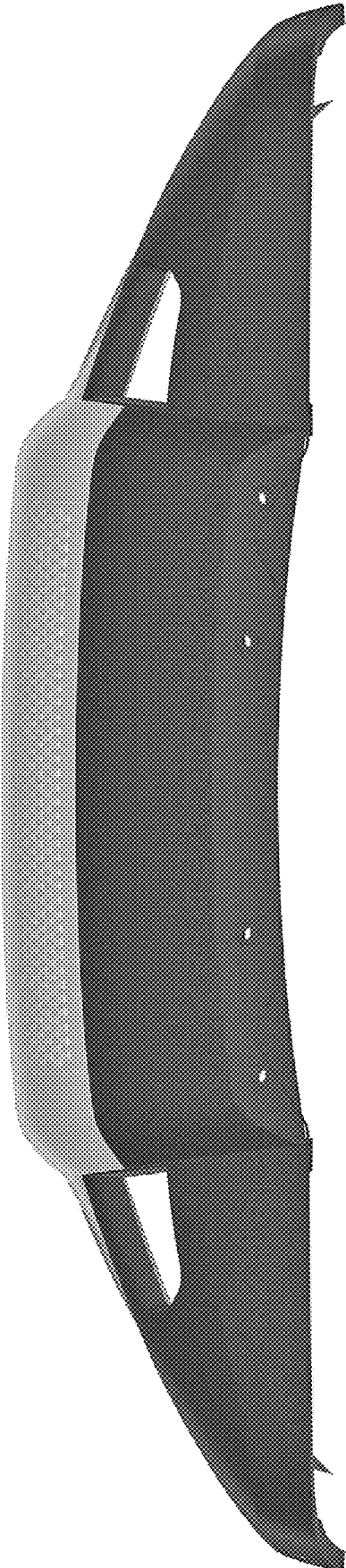

FIG. 10

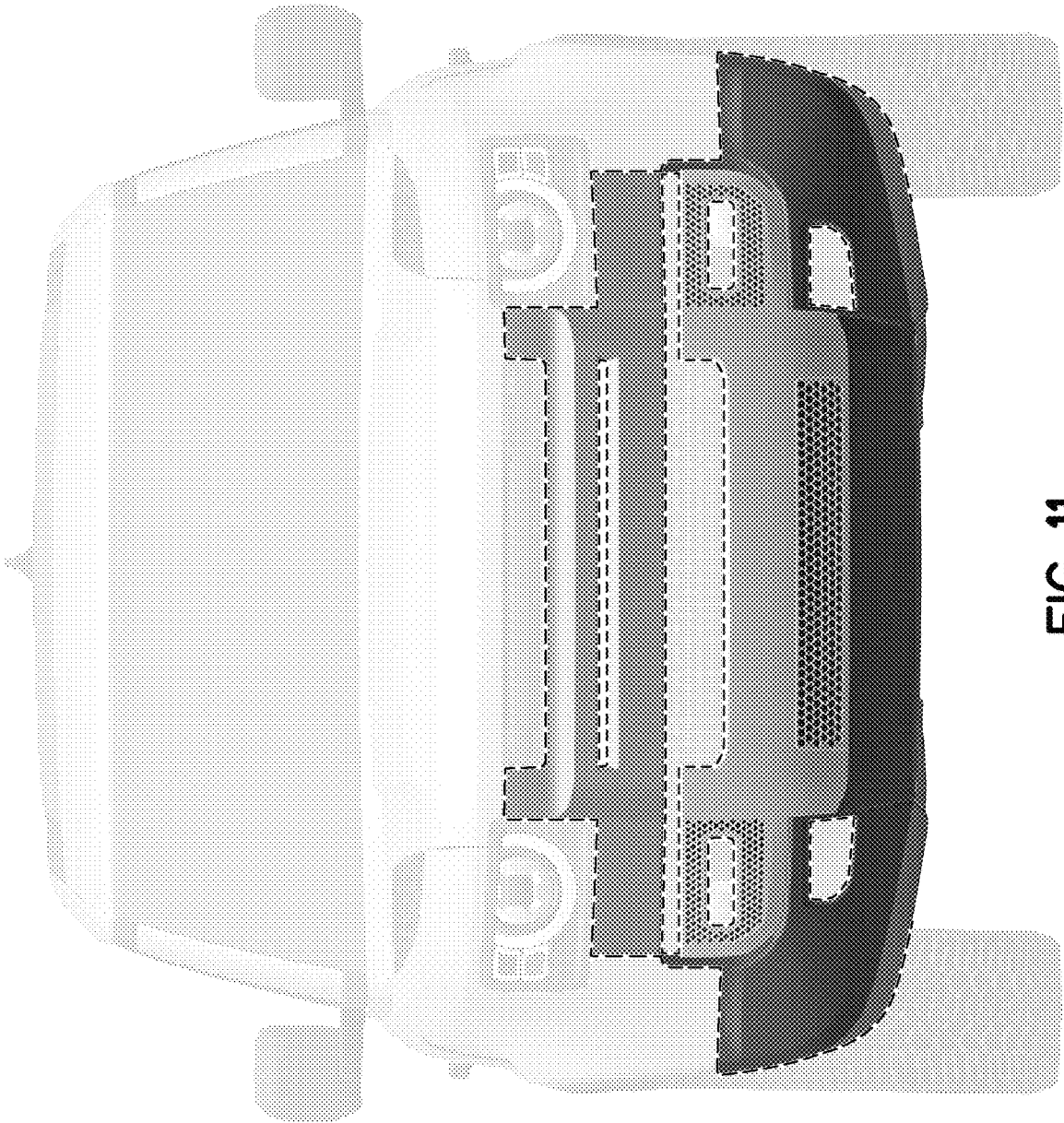

FIG. 11