

(19) AUSTRALIAN PATENT OFFICE

(54) Title
Squeeze-activated medical puncturing device

(51)⁶ International Patent Classification(s)
A61B 5/15 (2006.01) 20060101AFI2006061
A61B 5/15 7BMEP
PCT/US2005/014968

(21) Application No: 2005240071 (22) Application Date: 2005 .04 .29

(87) WIPO No: W005/107595

(30) Priority Data

(31) Number	(32) Date	(33) Country
60/568,369	2004 .05 .05	US

(43) Publication Date : 2005 .11 .17

(71) Applicant(s)
Becton, Dickinson and Company,

(72) Inventor(s)
Battles, Christopher A., DiCesare, Paul, Radziunas, Jeffrey

(74) Agent/Attorney
FB Rice, Level 23 44 Market Street, Sydney, NSW, 2000

(56) Related Art
US 5755733
US 4817603
US 4900311
EP 1219242
US 6136013
US 6626868
US 5540709
US 6719771
US 6432120
US 3760809
US 4869249
US 6248120
US 6168606

(12) INTERNATIONAL APPLICATION PUBLISHED UNDER THE PATENT COOPERATION TREATY (PCT)

(19) World Intellectual Property
Organization
International Bureau



(43) International Publication Date
17 November 2005 (17.11.2005)

PCT

(10) International Publication Number
WO 2005/107595 A1

- (51) International Patent Classification⁷: **A61B 5/15**, A61M 5/32 (74) Agent: **HIGHET, David, W.**; Becton Dickinson and Company, 1 Becton Drive, Franklin Lakes, NJ 07417-1880 (US).
- (21) International Application Number: PCT/US2005/014968
- (22) International Filing Date: 29 April 2005 (29.04.2005)
- (25) Filing Language: English
- (26) Publication Language: English
- (30) Priority Data: 60/568,369 5 May 2004 (05.05.2004) US
- (71) Applicant (for all designated States except US): **BECTON DICKINSON AND COMPANY** [US/US]; 1 Becton Drive, Franklin Lakes, NJ 07417-1880 (US).
- (72) Inventors; and
- (75) Inventors/Applicants (for US only): **RADZIUNAS, Jeffrey** [US/US]; 1125 Durham Road, Wallingford, CT 04692 (US). **DICESARE, Paul** [US/US]; 68 Wells Hill Road, Easton, CT 06612 (US). **BATTLES, Christopher, A.** [US/US]; 78 Olive Street, Apt. #432, New Haven, CT 06510 (US).
- (81) Designated States (unless otherwise indicated, for every kind of national protection available): AE, AG, AI, AM, AT, AU, AZ, BA, BB, BG, BR, BW, BY, BZ, CA, CI, CN, CO, CR, CU, CZ, DE, DK, DM, DZ, EC, EE, EG, ES, FI, GB, GD, GE, GH, GM, HR, HU, ID, IL, IN, IS, JP, KE, KG, KM, KP, KR, KZ, LC, LK, LR, LS, LT, LU, LV, MA, MD, MG, MK, MN, MW, MX, MZ, NA, NI, NO, NZ, OM, PG, PH, PL, PT, RO, RU, SC, SD, SE, SG, SK, SL, SM, SY, TJ, TM, TN, TR, TT, TZ, UA, UG, US, UZ, VC, VN, YU, ZA, ZM, ZW.
- (84) Designated States (unless otherwise indicated, for every kind of regional protection available): ARIPO (BW, GH, GM, KE, LS, MW, MZ, NA, SD, SI, SZ, TZ, UG, ZM, ZW), Eurasian (AM, AZ, BY, KG, KZ, MD, RU, TJ, TM), European (AT, BE, BG, CH, CY, CZ, DE, DK, EE, ES, FI, FR, GB, GR, HU, IE, IS, IT, LT, LU, MC, NL, PL, PT, RO, SE, SI, SK, TR), OAPI (BF, BJ, CF, CG, CI, CM, GA, GN, GQ, GW, ML, MR, NE, SN, TD, TG).

[Continued on next page]

(54) Title: SQUEEZE-ACTIVATED MEDICAL PUNCTURING DEVICE

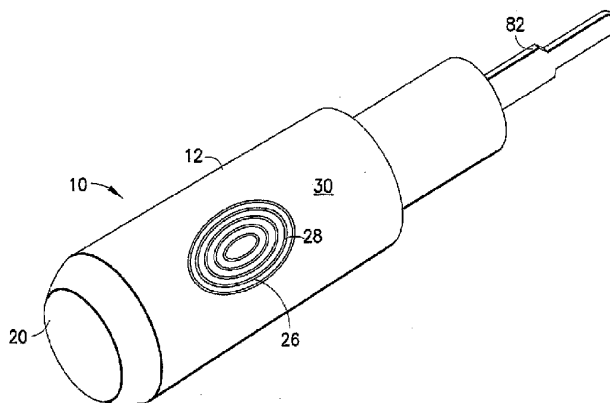

(57) Abstract: The medical puncturing device (10) includes a housing (12) having a proximal end (18) and a distal end (16) and a skin puncturing assembly (14) within the housing. The skin puncturing assembly includes a movable carrier (50) and a skin puncturing element (52). The skin puncturing element is adapted to puncture the skin of a patient. The carrier is movable from a retracted position wherein a distal tip of the skin puncturing element is disposed within the housing, to a puncturing position wherein the distal tip is exposed to puncture the skin of the patient. The carrier is moved from the retracted position to the puncturing position upon radial deformation of the housing. An internal guide (42) may be provided within the housing for guiding the movement of the carrier from the retracted position to the puncturing position.

WO 2005/107595 A1



Declaration under Rule 4.17:

— of inventorship (Rule 4.17(iv)) for US only

Published:

— with international search report

For two-letter codes and other abbreviations, refer to the "Guidance Notes on Codes and Abbreviations" appearing at the beginning of each regular issue of the PCT Gazette.

SQUEEZE-ACTIVATED MEDICAL PUNCTURING DEVICE

5

BACKGROUND OF THE INVENTION

1. Field of the Invention

present invention relates generally to medical puncturing devices, commonly
10 referred to as lancets, used to take blood samples from patients and, more specifically,
to a medical puncturing device that ensures sterility before use, and safe and secure
disposal after use.

2. Description of Related Art

Medical puncturing devices are used in the medical field for puncturing the
15 skin of a patient to obtain a capillary blood sample from the patient. Certain diseases,
such as diabetes, require that the patient's blood be tested on a regular basis to
monitor, for example, the patient's blood sugar levels. Additionally, test kits, such as
cholesterol test kits, often require a blood sample for analysis. The blood collection
20 procedure usually involves pricking a finger or other suitable body part in order to
obtain the blood sample. Typically, the amount of blood needed for such tests is
relatively small and a small puncture wound or incision normally provides a sufficient
amount of blood for these tests.

Various medical puncturing devices are commercially available to hospitals,
clinics, doctors' offices, and the like, as well as to individual consumers. Such devices
25 typically include a sharp-pointed member such as a needle, or a sharp-edged member
such as blade, that is used to make a quick puncture wound or incision in the patient's
skin in order to provide a small outflow of blood. It is often physiologically and
psychologically difficult for many people to prick their own finger with a hand-held
needle or blade. As a result, medical puncturing devices have evolved into automatic
30 devices that puncture or cut the skin of the patient upon the actuation of a triggering
mechanism. In some devices, the needle or blade is kept in a standby position until it

is triggered by the user, who may be a medical professional in charge of drawing blood from the patient, or the patient himself or herself. Upon triggering, the needle or blade punctures or cuts the skin of the patient, for example on the finger. Often, a spring is incorporated into the device to provide the "automatic" force necessary to
5 puncture or cut the skin of the patient.

It is important in the medical field that such medical puncturing devices or lancets be in a sterile condition before use. Today, medical puncturing devices or lancets are manufactured and packaged in a sterilized condition before they are distributed to medical professionals and members of the public who have a need for
10 such devices. The sterile packaging maintains the sterility of the device, ensuring that the surrounding environment does not contaminate it until use. In addition, it is also of increasing importance that the user or another person does not come into contact with the needle or blade after use of the device. With the concern over blood-borne diseases, medical professionals are required to take great care with medical devices
15 that come into contact with the blood of patients. Thus, an important aspect of medical puncturing device/lancet design is concerned with preventing the needle or blade of the device from wounding the user or another person after the blood sample is drawn from the patient. Once used, the needle or blade should be shielded to prevent the needle or blade from wounding the user or another person handling the
20 device. Moreover, the medical puncturing device or lancet should be disposable to eliminate the chances of disease transmission due to the needle or blade being used on more than one person. In this regard, the medical puncturing device or lancet should ideally be designed for one firing, and have safety features to prevent reuse.

Advances have been made in recent years to increase safety in operating and
25 handling used medical puncturing devices. For example, medical puncturing devices are currently available which are single shot devices that feature automatic ejection and retraction of the puncturing or cutting element from and into the device. Examples of such medical puncturing devices are disclosed in U.S. Patent Nos. 6,432,120; 6,248,120; 5,755,733; and 5,540,709.

30 U.S. Patent No. 6,432,120 to Teo discloses a lancet assembly that includes a lancet holder, which contains a spring-loaded lancet structure. The spring-loaded

lancet structure includes a single spring that effects the ejection and retraction of a lancet needle upon the triggering of the structure. U.S. Patent No. 6,248,120 to Wyszogrodzki discloses a puncturing device comprised of a housing, shielding portion, a piston with a puncturing tip, and drive and return springs that eject and retract the piston, respectively, upon the breakage of internal wing elements in the housing. U.S. Patent No. 5,755,733 to Morita discloses a lancet assembly that includes a combined holder and lancet structure. The lancet structure includes a lancet member with a puncturing tip and a compressible spring member that causes the lancet member to puncture the skin of a patient upon actuation of a pair of actuating arms.

U.S. Patent No. 5,540,709 to Ramel discloses a lancet device that includes a housing enclosing a slidable trigger, which is used to trigger a compressed spring that powers a piercing lancet member to pierce the skin of a patient. The housing includes a pair of internal fingers that engage the body of the lancet member, which are then released of engagement with the lancet member body by axial force applied by the user to the slidable trigger. Other medical puncturing devices or lancets known in the art are disclosed in U.S. Patent Nos. 4,869,249 and 4,817,603. The devices disclosed in these references include a cap that is used to protect the needle or to keep the needle sterile.

U.S. Patent Nos. 6,136,013 to Marshall et al. and 6,719,771 to Crossman disclose a lancet device that includes a housing with a trigger integral with the housing in the form of a tongue provided by a U-shaped cut in the housing. The tongue is deformable inwardly and when depressed, passes through an aperture (e.g. cut-out, gap, or opening) in the housing and causes release or disengagement of a piercing lancet member to pierce the skin of a patient.

Other medical puncturing devices or lancets known in the art are disclosed in U.S. Patent Nos. 4,869,249 and 4,817,603. The devices disclosed in these references include a cap that is used to protect the needle or to keep the needle sterile.

Any discussion of documents, acts, materials, devices, articles or the like which has been included in the present specification is not to be taken as an admission that any or all of these matters form part of the prior art base or were common general knowledge in the field relevant to the present invention as it existed before the priority date of each claim of this application.

SUMMARY OF THE INVENTION

Throughout this specification the word "comprise", or variations such as "comprises" or "comprising", will be understood to imply the inclusion of a stated element, integer or step, or group of elements, integers or steps, but not the exclusion of any other element, integer or step, or group of elements, integers or steps.

In view of the foregoing, a need generally exists in the medical field for an improved medical puncturing device that ensures sterility before use, and safe and secure disposal after use. Additionally, a need exists in the medical field for a simple, inexpensive, reliable, self-activating, and disposable medical puncturing device for use in collecting blood samples. Moreover, there is a need for a medical puncturing device in which production of puncture wounds and/or incisions is consistent and well-controlled.

In one aspect, there is provided a medical puncturing device, comprising:

a deformable housing, wherein at least a portion of the deformable housing includes a continuous cross-section, wherein a portion of the continuous cross-section includes at least one point of deformation; and

a skin puncturing element disposed within the housing and maintained in a retracted first position against a biasing force prior to deformation of the deformable housing through an interference engagement between the deformable housing and a skin puncturing element, wherein a tip of the skin puncturing element is disposed within the deformable housing,

wherein, upon deformation of the housing at the at least one point of deformation, the skin puncturing element is movable from the first position to a second position causing the tip to be exposed..

4A

In accordance with another aspect, there is provided a medical puncturing device, comprising:

5 a deformable housing having a proximal end and a distal end, wherein at least a portion of the deformable housing includes a continuous cross-section, wherein a portion of the continuous cross-section includes at least one point of deformation;

10 a skin puncturing assembly disposed within the housing and comprising a movable carrier and a skin puncturing element mounted to the carrier, the skin puncturing element comprising a distal tip for puncturing the skin of a patient, the carrier movable from a retracted position wherein the sharp distal tip is disposed within the housing to a puncturing position wherein the distal tip is exposed to puncture the skin of the patient, the carrier being maintained in the retracted position against a biasing force prior to deformation of the deformable housing;

15 wherein one of the housing and carrier includes at least one detent in interference engagement with at least one engagement formed in the other of the housing and carrier for securing the carrier in the retracted position against the biasing force; and

20 wherein radial deformation of the housing causes the at least one detent to move out of interference engagement with the at least one engagement, such that the carrier is moved from the retracted position to the puncturing position.

In yet another aspect of the invention, there is provided a medical puncturing device, comprising:

25 a deformable housing wherein at least a portion of the deformable housing includes a continuous cross-section, wherein a portion of the continuous cross-section includes at least one point of deformation; and

30 a skin puncturing element disposed within the housing and maintained in a retracted first position against a biasing force prior to deformation of the deformable housing through an interference engagement between the deformable housing and a skin puncturing element, wherein a tip of the skin puncturing element is disposed within the deformable housing,

wherein, upon radial deformation of the housing, the skin puncturing element is movable from the first position to a second position causing the tip to be exposed.

5 BRIEF DESCRIPTION OF THE DRAWINGS

- FIG. 1 is a perspective view of a medical puncturing device in accordance with the present invention, showing the device with a removable tip guard;
- FIG. 2 is a perspective view of the medical puncturing device shown in FIG. 1 viewed from an opposite side of the device;
- 10 FIG. 3 is an elevational view of the medical puncturing device shown in FIGS. 1 and 2;
- FIG. 4 is a longitudinal cross-sectional view of the medical puncturing device shown in FIGS. 1 and 2;
- FIG. 5 is a cross-sectional view taken along line 5-5 in FIG. 4;
- FIG. 6 is a cross-sectional view of the medical puncturing device shown in FIGS. 1 and
- 15 2 prior to actuation of the device and with the tip guard removed;
- FIG. 7 is a cross-sectional view taken along line 7-7 in FIG. 6, showing the direction of forces applied to actuate the device;
- FIG. 8 is a cross-sectional view of the medical puncturing device shown in FIGS. and 2, showing the device immediately after actuation with a skin piercing element of the
- 20 device exposed momentarily to pierce the skin of a patient;
- FIG. 9 is a cross-sectional view of the medical puncturing device shown in FIGS. 1 and 2, showing the device after actuation with the skin piercing element returned into the body of the device;
- FIG. 10 is a cross-sectional view of an alternative configuration of the medical
- 25 puncturing device of the present invention;
- FIG. 11 is a cross-sectional view of an alternative embodiment of the medical puncturing device of the present invention; and
- FIG. 12 is a cross-sectional view taken along line 12-12 in FIG. 11, showing the
- 30 direction of forces applied to actuate the device.

DETAILED DESCRIPTION OF THE INVENTION

For purposes of the description hereinafter, the terms “upper”, “lower”, “right”, “left”, “vertical”, “horizontal”, “top”, “bottom”, and derivatives thereof shall relate to the invention as it is oriented in the drawing figures. However, it is to be understood that the invention may assume many alternative variations and step sequences except where expressly specified to the contrary. It is also to be understood that the specific devices and processes illustrated in the attached drawings and described in the following text are simply exemplary embodiments of the invention. Hence, specific dimensions and other physical characteristics related to the embodiments disclosed hereinafter are not to be considered limiting.

Referring to FIGS. 1-5, a medical puncturing device or lancet **10** (hereinafter “puncturing device **10**”) in accordance with the present invention is generally illustrated. The puncturing device **10** generally includes a housing **12** and a skin puncturing assembly **14** disposed within the housing **12**. The housing **12** is preferably a generally tubular structure having a distal end **16** and a proximal end **18**. The housing **12** is preferably open-ended at the distal and proximal ends **16, 18**. An end cap **20** may be provided at the proximal end **16** of the housing **12** to close the proximal end **18** of the housing **12**. Alternatively, the housing **12** may be formed to have a closed proximal end **18** instead of the end cap **20** illustrated in FIG. 4. The closed proximal end **18** of the housing **12** would be integrally formed with the remainder of the body of the housing **12** in this variation of the puncturing device **10**. As shown in FIG. 4, the housing distal end **16** may be formed with an internally-extending portion **22**. The internally-extending portion **22** defines a recess or pocket **24** for housing a spring or other biasing element as discussed further herein.

Preferably, the housing **12** is made of a resiliently deformable material, such as suitable medical grade plastic, which allows the housing to be deformed radially toward a central axis **L** of the housing **12**, to actuate the puncturing device **10** as discussed herein. The end cap **20** may also be made of a similar material to the housing **12**. The housing **12** may have any suitable cross-sectional shape, such as oval, circular, or polygonal. However, because the housing **12** is intended to be

grasped between the fingertips of the user of the puncturing device 10, the cross-sectional shape of the housing 12 is preferably selected so that the housing 12 is easily manipulated by the user's fingertips. An oval or circular cross-sectional shape for the housing 12 best fits this requirement and is presently preferred. Additionally, the housing 12 is formed with finger pads 26 provided on opposing sides of the housing 12 for grasping by the user of the puncturing device 10. The finger pads 26 illustrated in FIGS. 1-3 are formed as concentric oval rings 28 and are raised from an outer or external surface 30 of the housing 12 to provide gripping surfaces for the user of the puncturing device 10. The finger pads 26 provide a tactile indication of where the user of the puncturing device 10 should place his or her fingertips to actuate the puncturing device 10 in the manner described in detail herein.

The end cap 20, if present, is engaged with the housing 12 by a frictional, snap-fit type of engagement. Once engaged with the housing 12, the frictional engagement between the end cap 20 and housing 12 is of sufficient strength to substantially prevent the end cap 20 from being removed easily from the housing 12 to reduce the ability of a user of the puncturing device 10 to tamper with the puncturing device 10 after manufacturing. In particular, the end cap 20 includes a circumferential detent 32 that cooperates with a circumferential recess 34 formed in an internal surface 36 of the housing 12. To further secure the connection between the end cap 20 and housing 12, a medical-type adhesive may be provided in the recess 34 during the assembling process for the puncturing device 10, thereby adhesively securing the detent 32 in the recess 34.

The housing 12 is further formed with opposing internal pockets 40 formed by opposing internally-extending portions 41 of the housing 12. The internal pockets 40 are adapted to restrain the movement of the skin puncturing assembly 14 within the housing 12, as discussed herein. Additionally, the housing 12 is formed with internal guides 42 for guiding the movement of the skin puncturing assembly 14 within the housing 12, once the skin puncturing assembly 14 is released of engagement with the internal pockets 40. The guides 42 are preferably in the form of internal guide tracks 44. The guide tracks 44 may be formed integrally with the housing 12, and generally extend along the internal surface 36 of the housing 12. The guide tracks 44 generally

extend from an area proximate to the end cap 20 to a distal portion 46 of the housing 12, where the diameter of the housing 12 is reduced or necked inward. The distal portion 46 of the housing 12 generally encompasses or surrounds the internally-extending portion 22 of the housing 12 discussed previously. The internal pockets 40 and guides 42 are formed in the housing 12 along respective transverse axes S_1 , S_2 ,
5 which are oriented approximately perpendicular to each other (i.e., about 90° apart) for proper operation of the puncturing device 10, as discussed herein. The fingerpads 26 are formed generally along axis S_2 to ensure proper operation of the puncturing device 10, as discussed herein, but may be formed along axis S_1 in an alternative embodiment
10 of the puncturing device 10 shown in FIGS. 11 and 12.

As shown in the Fig. 5 (as well as Figs. 7, 10 and 12), a cross-section view cut through the housing at the location point wherein radial deformation causes release of interfering engagement is continuous in nature, such that cuts or gaps in the housing are not necessary for causing release of the interfering engagement holding the carrier
15 in the retracted position. Having cuts or gaps in the housing can be disadvantageous and may add to the molding complexity of puncture devices. By providing a housing that is continuous in nature at a radial deformation point allows for simplified molding of housing components for puncturing devices. Additionally, since gaps or cuts in the housing are not needed or may be reduced, blood that remains on the sharp distal tip
20 after use is further protected from leaking out of the housing through gaps or cuts that sometimes exist in the lancet housing.

The skin puncturing assembly 14 is disposed within the housing 12 as illustrated in FIG. 4. The skin puncturing assembly 14 is generally comprised of an elongated carrier member 50 (hereinafter "carrier 50") and a skin puncturing element
25 52. The skin puncturing element 52 may be a needle, blade, or like puncturing or cutting element, and includes a sharp distal tip 54 for puncturing or cutting the skin of a patient from which a blood sample is to be taken. The carrier 50 is movably mounted in the housing 12 as discussed herein. The carrier 50 preferably has a generally cylindrical shape to fit within the preferred oval or circular-shaped cross-sectional shape of the housing 12. However, other cross-sectional shapes for the
30 carrier 50, such as polygonal, are also within the scope of the present invention.

The carrier **50** includes a first or distal end **56** and a second or proximal end **58**. The distal end **56** faces the distal end **16** of the housing **12**. Likewise, the proximal end **58** of the carrier **50** faces the proximal end **18** of the housing **12** and the end cap **20**. The body of the carrier **50** is formed with a substantially cylindrical-shaped distal portion **60** and a substantially cylindrical-shaped proximal portion **62** extending from the distal and proximal ends **56**, **58** of the carrier **50**, respectively. The skin puncturing element **52** generally extends from the distal end **56** of the carrier **50** and is received within a central bore **64** formed within the distal portion **60** of the carrier **50**. The skin puncturing element **52** may be secured in the central bore **64** by a medical grade adhesive or by other means customary in the medical field. The skin puncturing element **52** is depicted in the Figures of this disclosure as a needle. However, as indicated previously, the skin puncturing element **52** is not necessarily limited to a needle or other puncturing-type element, but could also be a blade for causing an incision-type wound in the skin of a patient when the puncturing device **10** is activated.

The carrier **50** is further preferably formed with two opposing pairs of detents **66**, **68** that are used to secure the carrier **50** in a pre-actuated state in the housing **12** and guide the movement of the carrier **50** in housing **12** when the puncturing device **10** is actuated by a user. First pair of detents **66** engages or cooperates with the internal pockets **40** in the housing **12** to secure the carrier **50** in the pre-actuated or "retracted" position, as shown in FIG. 4. The second pair of detents or guide elements **68** engages or cooperates with the internal guides **42** and, more particularly, the guide tracks **44** in the housing **12** to guide the movement of the carrier **50** from the retracted position as shown in FIG. 4 to an extended or puncturing position, which is illustrated in FIG. 8 discussed herein. As shown in FIG. 5, the carrier **50** is formed such that the two pairs of opposing detents **66**, **68** form a crosshair-type configuration with the housing **12**, and extend along orthogonal axes S_1 , S_2 , respectively.

The guides **42** (i.e., guide tracks **44**) and detents or guide elements **68** cooperating therewith are entirely optional in the puncturing device **10**, but this arrangement is preferred because it improves the reliability and performance of the puncturing device **10** by guiding the movement of the carrier **50** within the housing

12. Additionally, while embodiments of the present invention are described herein with reference to two opposing pairs of detents **66**, **68**, it will be appreciated that only one detent **66** engaging or co-acting with one internal pocket **40** is necessary to inhibit movement of the carrier **50** relative to the housing **12** for proper functioning of the puncturing device **10**. Similarly, the second pair of detents or guide elements **68** may be reduced to a single detent or guide element **68** engaging or co-acting with a single guide **42** (i.e., guide track **44**) in accordance with the present invention.

It will be appreciated that the locations of the detents **66** and internal pockets **40** may be reversed in accordance with an embodiment of the present invention, as generally illustrated in FIG. 10. Thus, the detents **66** could be made to extend from the internal surface or wall **36** of the housing **12** and cooperate with internal pockets **40** formed in the body of the carrier **50**. Likewise, the locations for the guide elements **68** and guides **42** (i.e., guide tracks **44**) may be reversed in accordance with the present invention. The guide elements **68** could be made to extend from the internal surface or wall **36** of the housing **12** and cooperate with guide tracks **44** formed in the body of the carrier **50**. Such reversals of locations are within the skill of those skilled in the art.

Referring again to FIGS. 1-5, the puncturing device **10** further includes a drive or firing spring **70** disposed in the housing **12** which, when activated, moves the puncturing assembly **14** within the housing **12**, and provides the force necessary to puncture the skin of a patient when the puncturing device **10** is used in a blood-drawing or collecting procedure. More particularly, the drive spring **70** is adapted to move the carrier **50** within the housing **12** from the retracted position shown in FIG. 4 to the extended or puncturing position, shown in FIG. 8 discussed herein, wherein the skin puncturing element **52** extends outward from the distal end **16** of the housing **12**, and the sharp distal tip **54** of the skin puncturing element **52** is exposed for causing a puncturing or incision-type wound in the skin of the patient.

The drive spring **70** is generally received at least partially about the proximal portion **62** of the carrier **50** and extends between the proximal portion **62** of the carrier **50** and an inner surface or side **72** of the end cap **20**. The inner side **72** of the end cap **20** may include a centering protrusion **74** to maintain the positioning of the drive

spring 70 prior to actuation of the puncturing device 10. As shown in FIG. 4, the drive spring 70 is preferably held in a compressed state within the housing 12 prior to actuation of the puncturing device 10 by interference engagement between the detents 66 on the carrier 50 and the internal pockets 40 in the housing 12. The proximal portion 62 of the carrier 50 is preferably tapered toward the central axis L, such that drive spring 70 is held securely on the proximal portion 62 by a frictional engagement therewith to maintain the drive spring 70 in the compressed state. A medical adhesive or a simple mechanical fastener may further be used to secure the drive spring 70 to the proximal portion 62. The crosshair configuration of the detents 66, 68 shown in FIG. 5 may further help maintain the drive spring 70 in the compressed state.

The puncturing device 10 optionally further includes a return or retraction spring 76 disposed in the housing 12 to provide the force necessary to generally return the skin puncturing assembly 14 to a static condition within the housing 12 after the puncturing device 10 is actuated by a user. More particularly, the retraction spring 76 provides the force necessary to return the carrier 50 to a position within the housing 12 wherein the skin puncturing element 52 and the sharp distal tip 54 thereof are fully contained within the housing 12. Generally, during actuation of the puncturing device 10, the drive spring 70 moves the carrier 50 from the retracted position (FIG. 4) wherein the sharp distal tip 54 of the puncturing element 52 is disposed within the housing 12 to the exposed or puncturing position (FIG. 8) wherein the sharp distal tip 54 emerges from the distal end 16 of the housing 12 for causing a puncturing or incision-type wound in the skin of a patient. The retraction spring 76 is generally used to return the carrier 50 to a position within the housing 12 wherein the skin puncturing element 52 is fully contained within the housing 12.

The retraction spring 76 is generally received about the distal portion 60 of the carrier 50 and extends between the distal portion 60 and the distal end 16 of the housing 12. In particular, a proximal end 78 of the retraction spring 76 is connected to the distal portion 60 of the carrier 50 and a distal end 80 of the retraction spring 76 is preferably seated in the pocket 24 formed by the internally-extending portion 22 of the housing 12. The retraction spring 76 generally acts between the distal portion 60 of the carrier 50 and the distal end 16 of the housing 12. The retraction spring 76 is in a

generally uncompressed state prior to actuation of the puncturing device **10** as shown in FIG. 4. The proximal and distal ends **78, 80** of the retraction spring **76** may be secured to the distal portion **60** of the carrier **50** and in the pocket **24**, respectively, by a suitable medical grade adhesive, if desired. Otherwise, a simple frictional engagement between the proximal and distal ends **78, 80** and the distal portion **60** of the carrier **50** and the pocket **24**, respectively, is all that is necessary to secure the retraction spring **76** to the carrier **50** and housing **12** in accordance with the present invention.

The skin puncturing assembly **14** may further include a protective tip guard **82** connected to the carrier **50**. The tip guard **82** may be formed integrally with the body of the carrier **50**, but includes a notched connection **84** with the distal end **56** of the carrier **50**. The notched connection **84** is entirely optional and the skin puncturing element **82** may be received in a central bore in the tip guard **82**, and be maintained therein by frictional engagement with the central bore in the tip guard **82**. The tip guard **82** extends outward from the distal end **16** of the housing **12** as shown in FIGS. 1-4. The notched connection **84** enables the user of the puncturing device **10** to break the integral connection between the tip guard **82** and carrier **50**, and remove the tip guard **82** prior to actuating the puncturing device **10**. The tip guard **82** ensures that the sharp distal tip **54** of the puncturing element **52** remains sterile before use and, further, protects the user against accidental puncture wounds that could be caused by inadvertent or premature actuation of the puncturing device **10**. The tip guard **82** may be removed by simply pulling on the tip guard **82** and/or moving the tip guard **82** in a side-to-side manner in the open distal end **16** of the housing **12** until the notched connection **84** with the carrier **50** breaks, as is well-known in the art.

The assembly of the puncturing device **10** is a simple and straight forward process. The housing **12** is first provided and, as discussed previously, includes the open distal and proximal ends **16, 18**. Next, the retraction spring **76** may be inserted into the open proximal end **16** of the housing **12**, such that the distal end **80** of the retraction spring **76** is received in the pocket **24** formed at the distal end **16** of the housing **12**. Once the retraction spring **76** is in place, the skin puncturing assembly **14** may be inserted into the open proximal end **18** of the housing **12**. The skin puncturing

assembly 14 is generally inserted into the housing 12 so that the detents 66, 68 engage the internal pockets 40 and guides 42 (i.e., guide tracks 44), respectively. The retraction spring 76 may be pre-assembled to the carrier 50, so that the retraction spring 76 is placed in position in the housing 12 during the same insertion step as the skin puncturing assembly 14. The internal pockets 40 and guides 42 ensure the skin puncturing assembly 14 is properly loaded into the housing.

With the retraction spring 76 and skin puncturing assembly 14 in place within the housing 12, the drive spring 70 may be inserted into the housing 12 through the open proximal end 18 of the housing 12. The drive spring 70 is received about the proximal portion 62 of the carrier 50 and extends from the proximal portion 62 towards the open proximal end 18 of the housing 12. The housing proximal end 18 is then closed with the end cap 20. The drive spring 70 is generally placed in a compressed, pre-actuated state within the housing 12 by affixing the end cap 20 to the housing proximal end 18. The assembled puncturing device 10 is now ready for use.

Referring to FIGS. 5-9, the sequence of actuation for the puncturing device 10 will now be discussed. FIG. 6 shows the puncturing device 10 in a pre-actuated state in a similar manner to FIG. 4 discussed previously, but with the tip guard 82 removed. In the pre-actuated state, the detents 66 of the carrier 50 are in interference engagement with the internal pockets 40 in the housing 12. The engagement of the detents 66 in the pockets 40 maintains the drive spring 70 in a compressed state between the end cap 20 and the proximal portion 62 of the carrier. Additionally, in the pre-actuated state, the retraction spring 76 extends between the distal portion 60 of the carrier 50 and the pocket 24 formed at the distal end 16 of the housing 12, but does not exert substantial force between these elements until the puncturing device 10 is actuated.

To actuate the puncturing device 10, the user grasps the housing 12 between the thumb and forefinger, preferably with the thumb and forefinger substantially engaging the fingerpads 26 on the external surface 30 of the housing 12. The user then placed the distal end 16 of the housing 12 in contact with the body part where a blood sample is to be taken. The fingerpads 26 are generally oriented along axis S_2 , which passes through the guides 42. Thus, the fingerpads 26 generally coincide with the guides 42 as shown in FIG. 7. The user then exerts inward or radial force, as

represented by arrows 90 in FIG. 7, on the housing 12 by squeezing the fingerpads 26 together. This simultaneously causes the housing 12 to deform or expand along axis S_1 , as represented by arrows 92 in FIG. 7. As the housing 12 deforms or expands along axis S_1 , the detents 66 engaging the internal pockets 40 are released from interference engagement with the internal pockets 40, thereby allowing the carrier 50 to move within the housing 12.

Once the interference engagement between the detents 66 and internal pockets 40 is released, the compressed drive spring 70 is also released. The drive spring 70 automatically biases or drives the carrier 50 toward the distal end 16 of the housing 12. The guides 42 (i.e., guide tracks 44) in the housing 12 guide the movement of the carrier 50 in the housing 12 toward the distal end 16 of the housing 12.

FIG. 8 shows the released movement of the carrier 50 in the housing 12. The carrier 50 is released from the retracted position or configuration shown in FIG. 6 and moves to the puncturing position or configuration shown in FIG. 8, wherein the puncturing element 52 extends from the distal end 16 of the housing 12 and the sharp distal tip 54 of the puncturing element 52 is fully exposed for piercing or cutting the skin of a patient. The carrier 50 is released by a simple act of squeezing the fingerpads 26 together to radially deform the housing 12. The direction of movement of the carrier 50 in the housing 12 is identified by arrow 94 in FIG. 8. In the puncturing position or configuration shown in FIG. 8, the skin puncturing element 52 of the skin puncturing assembly 14 reaches its maximum extension from the distal end 16 of the housing 12 and is driven under the force of the drive spring 70 into the skin of the patient (not shown). The drive spring 70 preferably has sufficient stored energy to cause the sharp distal tip 54 of the skin puncturing element 52 to pierce the skin of a person or animal once the carrier 50 is released from internal engagement with the housing 12.

FIG. 9 shows the ultimate disposition of the carrier 50 within the housing 12 after the puncturing device 10 has been activated. As the carrier 50 reaches the puncturing position wherein the sharp distal tip 54 of the skin puncturing element 52 is fully exposed, the retraction spring 76 is compressed between the distal portion 60 of the carrier 50 and the distal end 16 of the housing 12, as shown in FIG. 8. The

compression of the retraction spring 76 provides a return or retraction force that acts on the carrier 50 to move the carrier 50 in a return or retraction direction in the housing 12 as identified with arrow 96 in FIG. 9, which returns or retracts the skin puncturing element 52 and the sharp distal tip 54 thereof fully into the housing 12.

5 The retraction spring 76 thereafter prevents the re-emergence of the skin puncturing element 52 from the housing 12. If desired, a distal end cap 98 may be provided to enclose the distal end 16 of the housing 12 to further ensure that the skin puncturing element 52 will not extend outward from the housing 12 after the puncturing device 10 has been activated. The retraction spring 76 may be eliminated in the puncturing device 10 and the drive spring 70 used alone in the puncturing device 10. In this embodiment, tension force in the drive spring 70 is preferably sufficient to return the carrier 50 to the retracted position or configuration shown in FIG. 9. The variation of the puncturing device 10 having reversed locations for the detents 66 and internal pockets 40 operates in substantially the same manner to the procedure described

15 hereinabove.

FIGS. 11 and 12 show an alternative embodiment of the puncturing device 10, which is substantially similar in structure to the puncturing device 10 shown in FIGS. 1-9. The alternative embodiment of the puncturing device 10 generally modifies the interfering detent structure provided between the carrier 50 and the housing 12

20 described previously. In particular, the detents 66 on the carrier 50 are now preferably formed with respective hook elements or engagement members 100. The hook elements or engagement members 100 are preferably formed integrally with the detents 66 and the body of the carrier 50. The opposing internally-extending portions 41 of the housing 12 define hook-receiving openings 102 for receiving the hook elements or engagement members 100. The hook elements or engagement members 100 are generally adapted to engage the internally-extending portions 41 to maintain the carrier 50 in the retracted position within the housing 12. In operation, to allow the carrier 50 to move from the retracted position to the extended or puncturing position, the user of the puncturing device 10 will apply inward radial pressure on the

25 housing 12 along axis S_1 (i.e., the long radius of the housing 12), as represented by arrows 104 in FIG. 12. For this purpose, the fingerpads 26 may be oriented

30

substantially along axis S_1 rather than axis S_2 . As radial pressure is applied, the housing 12 will deform along axis S_2 (i.e., the short radius of the housing 12) by expanding along axis S_2 . As the housing 12 deforms along axis S_2 , the hook elements or engagement members 100 disengage from the internally-extending portions 41 of the housing 12, thereby releasing the carrier 50 to move distally in the housing 12 to the extended or puncturing position. As will be appreciated, the locations of the hook elements or engagement members 100 and hook-receiving openings 102 may be reversed in accordance with the present invention. Thus, the detents 66 may define the hook-receiving openings 102 and the internally-extending portions 41 of the housing 12 may be formed with the hook elements or engagement members 100. The puncturing device 10 will operate in an identical manner as that described hereinabove with such a reversal, which is within the skill of those skilled in the art.

While the present invention was described with reference to preferred embodiments of the medical puncturing device, those skilled in the art may make modifications and alterations to the present invention without departing from the scope and spirit of the invention. Accordingly, the above detailed description is intended to be illustrative rather than restrictive. The invention is defined by the appended claims, and all changes to the invention that fall within the meaning and range of equivalency of the claims are to be embraced within their scope.

THE CLAIMS DEFINING THE INVENTION ARE AS FOLLOWS:

1. A medical puncturing device, comprising:
a deformable housing, wherein at least a portion of the deformable housing
5 includes a continuous cross-section, wherein a portion of the continuous cross-section
includes at least one point of deformation; and
a skin puncturing element disposed within the housing and maintained in a
retracted first position against a biasing force prior to deformation of the deformable
housing through an interference engagement between the deformable housing and a
10 skin puncturing element, wherein a tip of the skin puncturing element is disposed
within the deformable housing,
wherein, upon deformation of the housing at the at least one point of
deformation, the skin puncturing element is movable from the first position to a second
position causing the tip to be exposed.
15
2. The medical puncturing device of claim 1, further comprising:
a carrier configured to move within the housing,
wherein the skin puncturing element is mounted to the carrier and moves in
concert with the carrier.
20
3. The medical puncturing device of claim 2, further comprising at least one guide
within the housing for guiding the movement of the skin puncturing element from the
first position to the second position.
- 25 4. The medical puncturing device of claim 3, wherein the at least one guide comprises:
at least one guide element provided on one of the housing and carrier; and
at least one guide track cooperating with the at least one guide element and
formed in the other of the housing and carrier for guiding the movement of the carrier
from the first position to the second position.
30
5. The medical puncturing device of any one of claims 2 to 4, further comprising:
at least one detent provided on one of the housing and carrier; and
at least one engagement formed in the other of the housing and carrier
cooperating with said at least one detent,
35 wherein the at least one engagement secures the carrier in the first position until
deformation of the housing.

- 5 6. The medical puncturing device of any one of claims 2 to 5, further comprising a drive spring disposed within the housing and acting between the carrier and a proximal end of the housing, the drive spring adapted to move the carrier from the first position to the second position upon deformation of the housing.
7. The medical puncturing device of claim 6, wherein the drive spring is integral with at least one of the housing and the carrier.
- 10 8. The medical puncturing device of any one of claims 2 to 7, further comprising a retraction spring disposed within the housing and acting between the carrier and the distal end of the housing, the retraction spring adapted to return the carrier to a position within the housing wherein the housing encompasses the skin puncturing element after the carrier reaches the second position.
- 15 9. The medical puncturing device of any one of claims 2 to 8, wherein an external surface of the housing comprises opposing finger pads for grasping by a user of the device and applying radial force to the housing to deform the housing.
- 20 10. The medical puncturing device of any one of claims 2 to 9, wherein the housing comprises opposing external finger pads for applying radial force to deform the housing, and wherein the carrier comprises at least one detent cooperating with at least one engagement in the housing for securing the carrier in the first position until deformation of the housing, the opposing finger pads located along an axis oriented
- 25 approximately perpendicular to an axis passing substantially through the at least one internal pocket to release the at least one detent from the at least one internal pocket upon deformation of the housing.
- 30 11. The medical puncturing device of any one of the preceding claims, wherein the continuous cross section is defined by a plane normal within 20° from a longitudinal axis through the puncturing device.
- 35 12. A medical puncturing device, comprising:
a deformable housing having a proximal end and a distal end, wherein at least a portion of the deformable housing includes a continuous cross-section, wherein a portion of the continuous cross-section includes at least one point of deformation;

5 a skin puncturing assembly disposed within the housing and comprising a
movable carrier and a skin puncturing element mounted to the carrier, the skin
puncturing element comprising a distal tip for puncturing the skin of a patient, the
carrier movable from a retracted position wherein the sharp distal tip is disposed within
the housing to a puncturing position wherein the distal tip is exposed to puncture the
skin of the patient, the carrier being maintained in the retracted position against a
biasing force prior to deformation of the deformable housing;

10 wherein one of the housing and carrier includes at least one detent in
interference engagement with at least one engagement formed in the other of the
housing and carrier for securing the carrier in the retracted position against the biasing
force; and

15 wherein radial deformation of the housing causes the at least one detent to move
out of interference engagement with the at least one engagement, such that the carrier is
moved from the retracted position to the puncturing position.

13. The medical puncturing device of claim 12, further comprising at least one internal
guide for guiding the movement of the carrier from the retracted position to the
puncturing position.

20 14. The medical puncturing device of claim 13, wherein the at least one internal guide
comprises at least one guide element provided on one of the housing and carrier and
cooperating with the at least one guide track formed in the other of the housing and
carrier for guiding the movement of the carrier from the retracted position to the
puncturing position.

25 15. The medical puncturing device of claim any one of claims 12 to 14, further
comprising a drive spring disposed within the housing and acting between the carrier
and the proximal end of the housing, the drive spring adapted to move the carrier from
the retracted position to the puncturing position upon deformation of the housing.

30 16. The medical puncturing device of claim 15, further comprising a spring disposed
within the housing and acting between the carrier and the distal end of the housing, the
spring adapted to return the carrier to a position within the housing wherein the housing
encompasses the skin puncturing element after the carrier reaches the puncturing
35 position.

17. The medical puncturing device of claim 12, further comprising a drive spring disposed within the housing and acting between the carrier and the proximal end of the housing, the drive spring adapted to move the carrier from the retracted position to the puncturing position upon deformation of the housing and having sufficient tension
- 5 force to return the carrier to a position within the housing wherein the housing encompasses the skin puncturing element after the carrier reaches the puncturing position.
18. The medical puncturing device of any one of claims 12 to 17, wherein an external
- 10 surface of the housing comprises opposing finger pads for applying radial force to deform the housing, the opposing finger pads located along and oriented approximately perpendicular to an axis passing substantially through the at least one internal pocket upon deformation of the housing.
19. The medical puncturing device of any one of claims 12 to 18, wherein the skin
- 15 puncturing element comprises at least one of a needle and a blade.
20. The medical puncturing device of any one of claims 12 to 19, wherein the at least
- 20 one engagement comprises a pocket.
21. A medical puncturing device, comprising:
- a deformable housing wherein at least a portion of the deformable housing
- includes a continuous cross-section, wherein a portion of the continuous cross-section
- includes at least one point of deformation; and
- 25 a skin puncturing element disposed within the housing and maintained in a retracted first position against a biasing force prior to deformation of the deformable housing through an interference engagement between the deformable housing and a skin puncturing element, wherein a tip of the skin puncturing element is disposed
- within the deformable housing,
- 30 wherein, upon radial deformation of the housing, the skin puncturing element is movable from the first position to a second position causing the tip to be exposed.
22. The medical puncturing device of claim 21, further comprising: a carrier configured
- 35 to move within the housing, wherein the skin puncturing element is mounted to the carrier and moves in concert with the carrier.

23. The medical puncturing device of claim 22, further comprising at least one guide within the housing for guiding the movement of the skin puncturing element from the first position to the second position.

5 24. The medical puncturing device of claim 22 or claim 23, further comprising: at least one detent provided on one of the housing and carrier; and at least one engagement formed in the other of the housing and carrier cooperating with said at least one detent, wherein the at least one engagement secures the carrier in the first position until deformation of the housing.

10 25. The medical puncturing device of any one of claims 21 to 24, wherein an external surface of the housing comprises opposing finger pads for grasping by a user of the device and applying radial force to the housing to deform the housing.

15

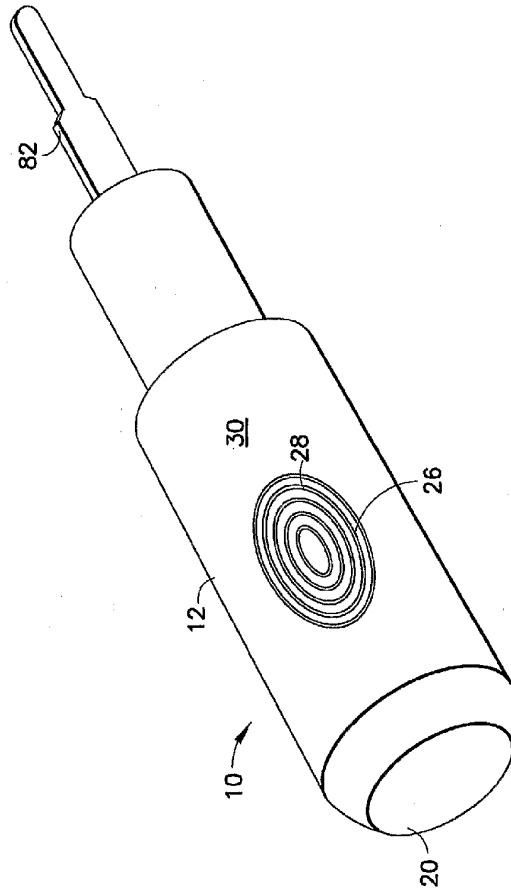

FIG. 1

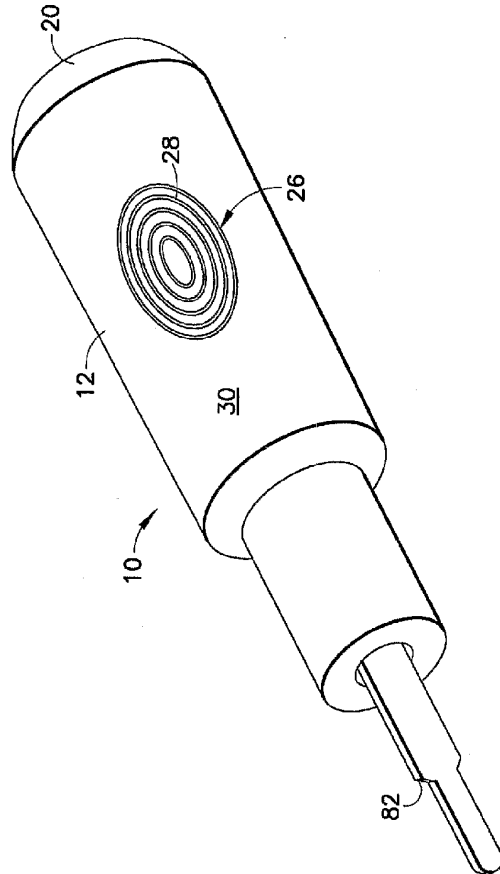

FIG. 2

3/9

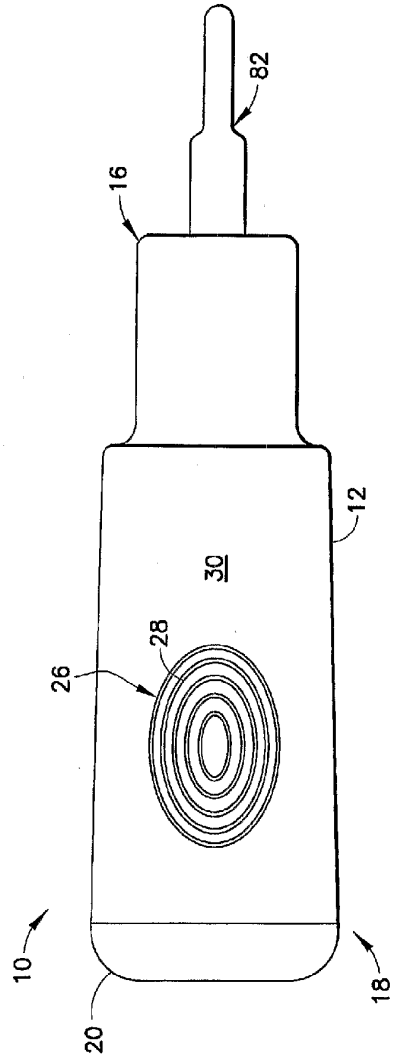

FIG. 3

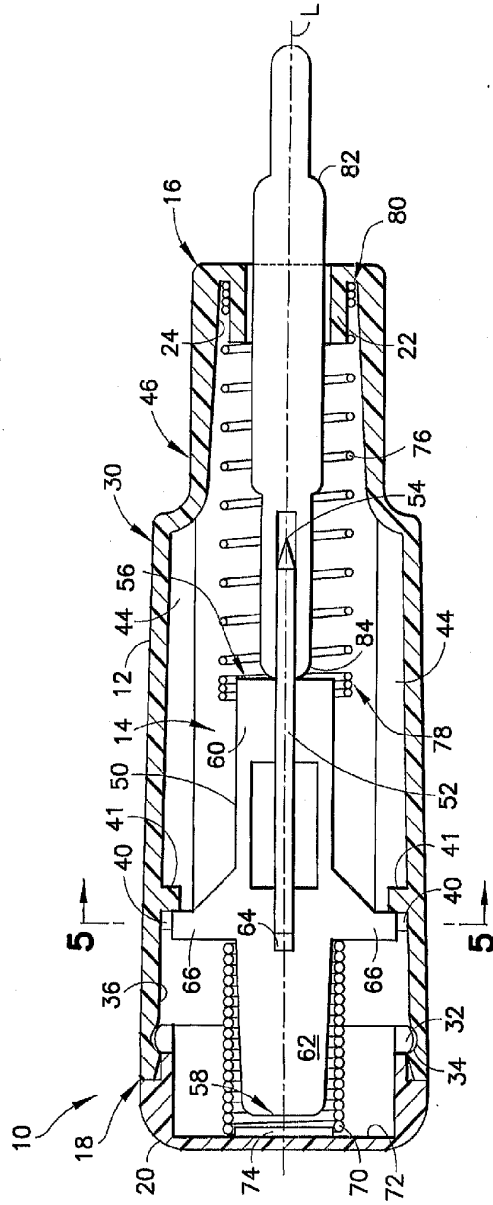

FIG. 4

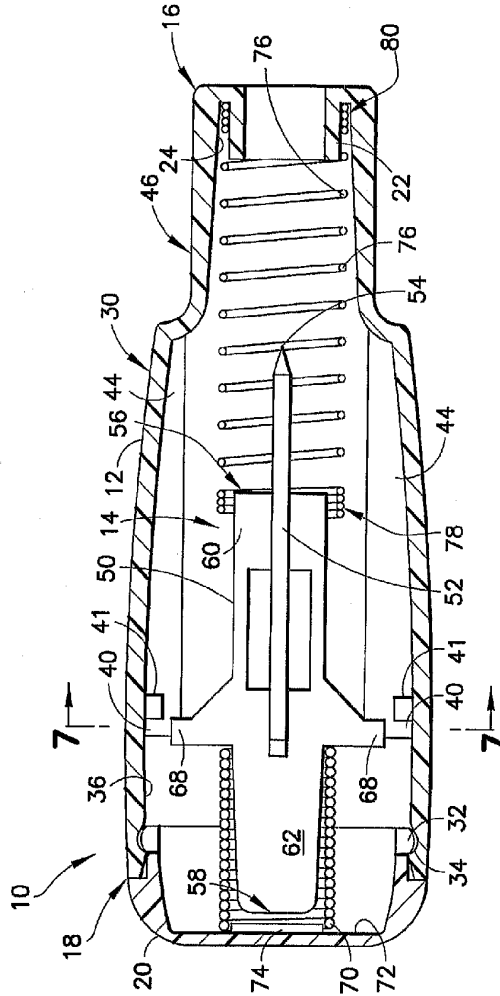

FIG. 6

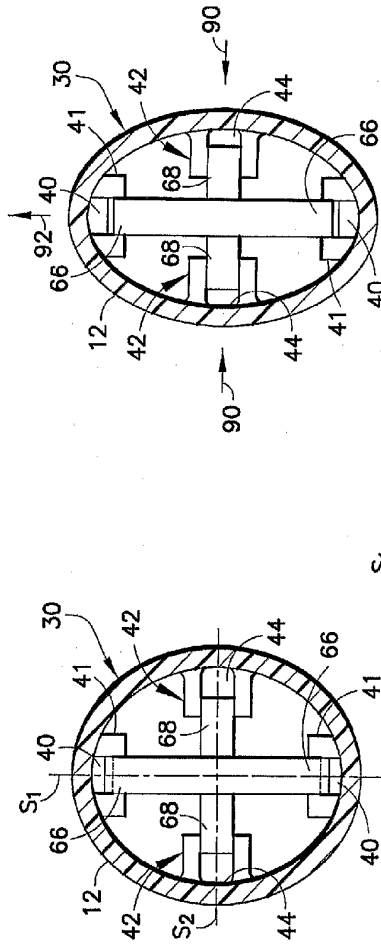

FIG. 5

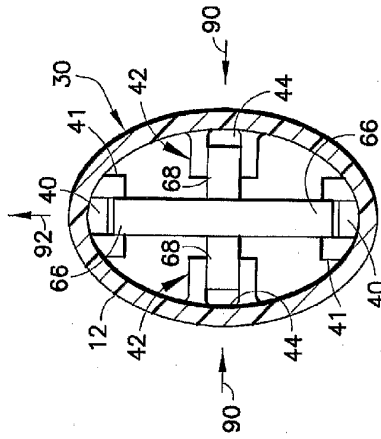

FIG. 7

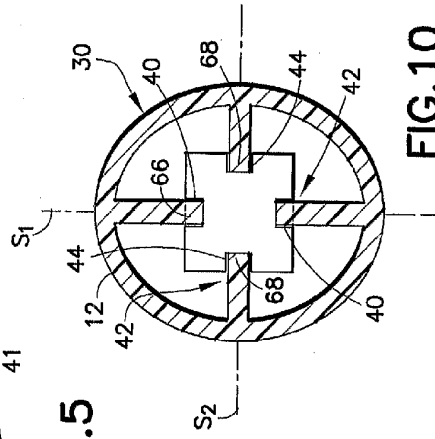

FIG. 10

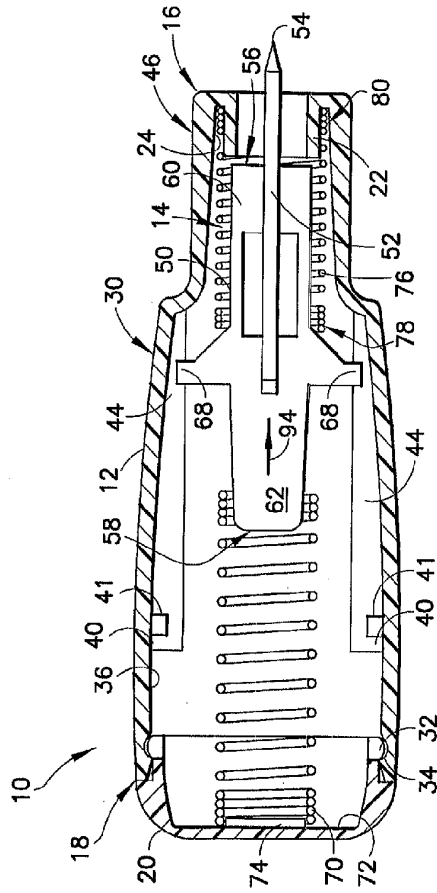

FIG. 8

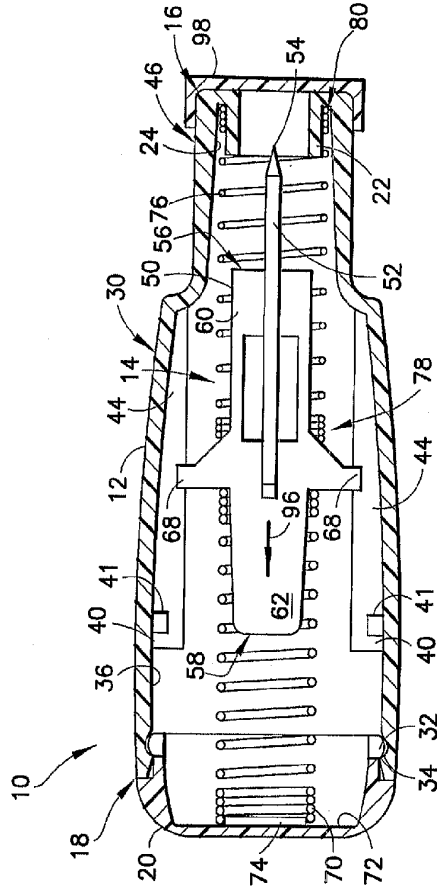

FIG. 9

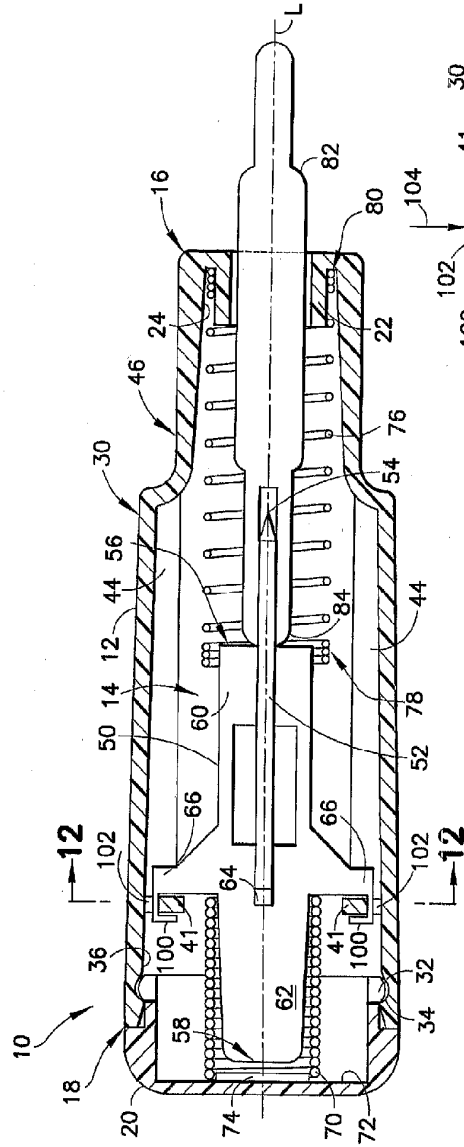

FIG. 11

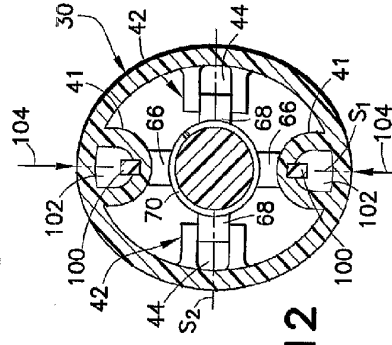

FIG. 12