



(11) **EP 2 259 270 A2**

(12) **EUROPEAN PATENT APPLICATION**

(43) Date of publication:
08.12.2010 Bulletin 2010/49

(51) Int Cl.:
H01B 7/285 (2006.01)

(21) Application number: **10164629.7**

(22) Date of filing: **01.06.2010**

(84) Designated Contracting States:
AL AT BE BG CH CY CZ DE DK EE ES FI FR GB GR HR HU IE IS IT LI LT LU LV MC MK MT NL NO PL PT RO SE SI SK SM TR
Designated Extension States:
BA ME RS

(72) Inventors:
• **Fjellberg, Jan Tore**
2070 Råholt (NO)
• **Brynildsen, Olav Trygg**
2150 Årnes (NO)
• **Dzubur, Mensudin**
2150 Årnes (NO)

(30) Priority: **02.06.2009 NL 1037007**

(71) Applicant: **Draka Comteq B.V.**
1083 HJ Amsterdam (NL)

(74) Representative: **Algemeen Octrooi- en Merkenbureau**
P.O. Box 645
5600 AP Eindhoven (NL)

(54) **Cable element, data transmission cable, method for manufacturing and use of data transmission cable.**

(57) The present invention relates to a cable element for high frequency data transmission comprising one single twisted pair of insulated electrical conductors surrounded by a first shielding layer thereby forming a first space between said twisted pair of insulated electrical conductors and an inner surface of said first shielding

layer.

An object of the present invention is to provide an improved data transmission cable comprising cable elements that can be used in outdoor conditions preferably without impairing data transmission performance of the cable.

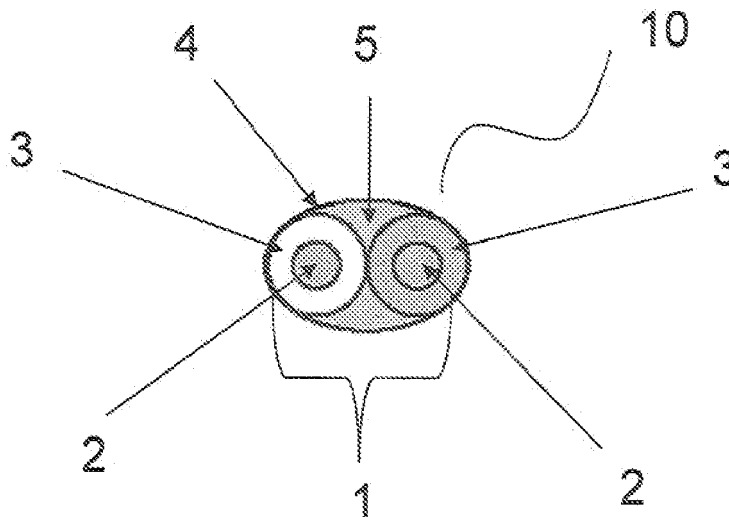

Figure 1

EP 2 259 270 A2

Description

[0001] The present invention relates to a cable element for high frequency data transmission comprising one single twisted pair of insulated electrical conductors surrounded by a first shielding layer thereby forming a first space between said twisted pair of insulated electrical conductors and an inner surface of said first shielding layer.

[0002] EP 0 572 173 relates to a communication cable having waterblocking capabilities. Such a cable has a plurality of metallic conductors, and one such cable comprises a plurality of individual copper conductors configured as twisted pairs. A plurality of these twisted pair conductors are tightly bundled together to create a series of units, wherein each unit is separately helically wrapped with a hydrophilic, water-absorptive yarn. The cable includes a core comprising one or more pairs of insulated metallic conductors, wherein a hydrophobic material is used as a filling compound to occupy any voids or interstices remaining within the core.

[0003] EP 0 586 158 relates to a cable comprising a plurality of longitudinally extending transmission media including a core having a plurality of insulated metallic conductor pairs, wherein the conductors may be grouped together in units and the units assembled together into the core. Binders are used to bind together the conductors, wherein the core is disposed within a plastic material which is wrapped. The core is filled with a superabsorbent polymer in powder form.

[0004] GB 2 164 198 relates to an optical fibre cable comprising a plurality of insulated wires stranded together and impregnated with a water-repellent medium and having on its surface a dusting of a water blocking powder. The coated wire bundle is surrounded in turn by an inner protective sheath of plastics materials extruded over the bundle, a metallic barrier strip and an outer plastics sheath extruded around the barrier strip.

[0005] US 6,686,537 and US 6,815,611 discloses high-performance data cables wherein on each twisted pair cable a lateral wrapped shielding tape is used, which shielding tape is bound with a fabric or metal binder to meet impedance/RL, attenuation uniformity and capacitance unbalance. By utilising this lateral wrapped shield most of the trapped air that is normally found in shielded twisted pair cables is eliminated.

[0006] US 2005/0077066 discloses a cable having a plurality of individually shielded twisted pairs, each individually shielded twisted pair including a shield comprised of multiple layers with a first surface and a second surface opposite the first surface. The shield has a first longitudinally extending side and a second longitudinally side. The shield is oriented around the twisted pair with a lateral fold or "cigarette wrap" fold. A portion of the laterally wrapped shield is bonded to itself. By bonding a portion of the shield to itself the shield forms a semi-rigid tube which encompasses the twisted pair.

[0007] The space between the twisted pair of insulated

electrical conductors and the first shielding layer in the cables according to the prior art is filled with air. When such prior art cables are used under outdoor conditions water may diffuse or leak into this space between the twisted pair of insulated electrical conductors and the first shielding layer. As a result of the ingres of water data transmission, especially at high frequencies, may be disturbed or even lost. The disturbance or loss of data transmission is ascribed to a too high level of dielectric loss (L), defined as the product of the relative dielectric permittivity (E) and the dissipation factor (D). This dielectric loss depends on the frequency and temperature at which the cable element is operated.

[0008] In this respect it is noted that this loss or disturbance of data transmission does not necessarily mean that the cable can no longer conduct electrical current.

[0009] A further problem associated with outdoor use of cables according to the prior art is that cable performance may be jeopardised due to application of outside forces or movements.

[0010] An object of the present invention is to provide an improved data transmission cable comprising cable elements that can be used in outdoor conditions preferably without impairing data transmission performance of the cable.

[0011] Another object of the invention is to provide a data transmission cable which is resistant to deformation.

[0012] The present invention is **characterised in that** at least part of the first space between the single twisted pair and an inner surface of the first shielding layer comprises a water blocking compound.

[0013] The presence of the water blocking compound in the first space blocks water from penetrating in the first space of the cable element. Likewise, even under circumstances where water would enter part of the first space, the water blocking compound will prevent further penetration inside the cable element in longitudinal direction thereof.

[0014] The present inventors have surprisingly found that a certain increase in dielectric loss, which loss increase is the result of the presence of the water blocking compound in the first space between the twisted pair of insulated electrical conductors and an inner surface of the first shielding layer, will not result in significant loss of data transmission performance.

[0015] Due to the presence of the water blocking compound the present inventors have also found that a cable element according to the present invention is more resistant to mechanical deformation.

[0016] Both these properties make the cable elements suitable for use in both indoor and outdoor data transmission cables.

[0017] In a preferred embodiment the relative dielectric permittivity of the water blocking compound is less than or equal to 4 and even more preferably less than or equal to 3 at the frequency and temperature at which the element is operated. Operating temperatures may be specified to be between -40 °C and 70 °Celsius.

[0018] When the relative dielectric permittivity is lower than or equal to 3 there is, when compared to the cable elements according to the prior art, no need to adjust the thickness of the insulation layer that surrounds the electrical conductors.

[0019] In a further preferred embodiment the dissipation factor of the water blocking compound is lower than or equal to 0.001 at the frequency and temperature at which the cable element is operated. If the dissipation factor of the water blocking compound is higher than 0.001, transmission loss increases towards an unacceptable level. The water blocking compound may be in the form of a gel such as for example a petroleum based gel or a silicone based gel, or in the form of a hotmelt.

[0020] A hotmelt as used hereinafter is defined as a material which at room temperature is a solid, whereas it can flow upon elevated temperatures, for example temperatures above 80 ° or even above 100 °Celsius.

[0021] In a preferred embodiment the water blocking compound is a hotmelt and more preferably a hotmelt adhesive. A hotmelt adhesive binds to both the insulated electrical conductors of the twisted pair and the first shielding layer.

[0022] In a further preferred embodiment the hotmelt is an elastomer-based adhesive. Preferably the hotmelt is a polyurethane or polyacrylate based material.

[0023] Such embodiment allows the cable element to be even more resistant to mechanical deformation, which results in more reliable data transmission behaviour, i.e. disturbance or loss of data transmission as a result of mechanical loads applied on the data transmission cable are reduced to a minimum.

[0024] A further advantage of a hotmelt is that such a material is relatively easy to handle when compared to for example gels. This is particularly relevant for the craftsman who has to splice or connectorise a cable in the field. He can remove the hotmelt from the twisted pair relatively easy without having the risk of soiling his hands, tools or clothes.

[0025] Yet another advantage of using a hotmelt material is that such a material can be processed relatively easy and enables production speeds comparable to those of conventional unfilled cable elements.

[0026] In this respect it is noted that the water blocking compound in the cable element of the present invention should not be confused with a water swellable material. More in particular, the present water blocking material is not a water swellable material.

[0027] A water swellable material will swell under the influence of water and thereby effectively block penetration of water both in radial and longitudinal direction of a cable or cable element. When first applied in a cable element during its manufacturing process, such water swellable materials may not result in disturbance or loss of data transmission at the operational frequency and temperature. However, when in use, the water swellable material may absorb water and as a result the overall composition of the thus obtained water swellable material

contains water.

[0028] Consequently the relative dielectric permittivity of the thus swollen water swellable material increases resulting in an increase of the dielectric loss to an unacceptable level, more in particular to values significantly above 0.01. Such values are too high in practice and may result in disturbance or loss of signal.

[0029] In a further preferred embodiment the first shielding layer is at least partly in contact with the single twisted pair of insulated electrical conductors. The single first shielding layer thus surrounds the single twisted pair relatively tightly, however still forms a first space between an inner surface of the first shielding layer and an outer surface of the single twisted pair of insulated electrical conductors. The first shielding layer is applied around the single twisted pair of insulated electrical conductors for the purpose of electrical shielding, more in particular for the purpose of reducing crosstalk phenomena.

[0030] The present invention is restricted to a cable element wherein the two insulated electrical conductors are twisted around and in intimate contact with each other in longitudinal direction. Such construction comprises additionally a shielding layer, said shielding layer surrounding only one single twisted pair of insulated electrical conductors.

[0031] Preferably the first shielding layer consists of or comprises an electrically conductive material, preferably a metal.

[0032] Embodiments of suitable shielding layers are aluminum laminated plastic foils. Further exemplary embodiments of the shielding layer are represented by the screening sheet as disclosed in US 2006/004896 or the shield system disclosed in WO 2006/105166. All these embodiments are hereby specifically incorporated by reference.

[0033] In yet another preferred embodiment the water blocking compound completely fills the first space along the length of the cable element, thereby making it impossible at any location along the length of the cable element for water to enter the first space.

[0034] The present invention further relates to a data transmission cable comprising at least one cable element according to the present invention wherein said at least one cable element is surrounded by an extruded outer sheath, the outer sheath defining a second space between an inner surface of the outer sheath and an outer surface of the at least one cable element.

[0035] In a specific embodiment the data transmission cable according to the invention consists of four cable elements.

[0036] The data transmission cable according to the invention may further comprise a second shielding layer surrounding the at least one cable element wherein said second shielding layer is surrounded by the outer sheath.

[0037] The second shielding layer should not be confused with the first shielding layer surrounding the twisted pair of insulated electrical conductors. The second shielding layer is not to be considered a part of the cable

element and also does not directly surround the single twisted pair of insulated electrical conductors. In the embodiment where the data transmission cable comprises more than one cable element the second shielding layer surrounds all the cable elements.

[0038] In the second space at least one water swellable and/or at least one water blocking material may further be present. The present inventors found that in the presence of such further water swellable and/or water blocking materials an even more robust and waterproof cable is obtained.

[0039] The data transmission cable and accordingly the cable elements according to the invention operate at relative high frequencies of at least 1 MHz preferably in a range from 1 to 1000 MHz more preferably from 100 to 1000 MHz.

[0040] For example, the data transmission cable according to the invention may be of the type Cat. 5, Cat. 5e, Cat. 6, Cat. 6a, Cat. 7, Cat. 7a as defined in international standard IEC 61156-5.

[0041] Typically the data transmission cable according to the invention does not contain strengthening or reinforcing elements such as longitudinal dielectric strength members, aramid yarns, glass reinforced rods and the like.

[0042] The data transmission cable according to the invention may be used as such, i.e. require no further circumferential layers or sheaths.

[0043] The data transmission cable according to the invention allows use at least partially in outdoor conditions, i.e. in conditions where the cable may be exposed to water or humidity at varying temperatures.

[0044] The present invention will now be described by means of the following figures which should not be construed as limiting in any way.

Fig. 1 shows a data communication cable element according to the present invention

Fig. 2 shows an embodiment of a data communication cable according to the present invention.

Fig. 3 shows a schematic representation of a production line for the manufacturing of cable element according to the present invention.

[0045] Figure 1 shows a schematic representation of a cable element 10 according to the present invention comprising one single twisted pair of two insulated electrical conductors 1, hereinafter referred to as twisted pair 1. Each of the two insulated electrical conductors of twisted pair 1 comprises a conductive core 2 covered by a layer of insulation 3. The two insulated electrical conductors of twisted pair 1 pair are twisted around and consequently in intimate contact with each other in longitudinal direction. No other conductors or elements form part of twisted pair 1.

[0046] Conductive core 2 may have a diameter ranging from approximately 400 μm to 700 μm , depending on the application. Conductive core 2 may be of the solid

type, i.e. consisting of a single wire of conductive material. In an alternative embodiment conductive core 2 is of the stranded type, wherein several strands of conductive material are stranded. For example, conductive core 2 may consist of seven strands where six strands are laid around a central strand.

[0047] Conductive core 2 sometimes referred to as core wire or wire is of an electrical conductive material, preferably a metal such as copper, plated copper, copper alloy or aluminum.

[0048] Insulation layer 3 may be made of a polymer material or a polymer compound comprising a polymer material such as polyethylene, polypropylene, ethylene-propylene copolymers, polyvinylchloride, fluor plastics such as polytetrafluorethylene. A polymer compound in this context should be understood to mean a polymer material whereto one or more additives are added. Examples of such additives are UV stabilisers, antioxidants, pigments, dyes, flame retardant additives and filler materials like talc and fused silica.

[0049] Insulation layer 3 may be solid or may be foamed, i.e. contain small air pockets. The wall thickness of insulation layer 3 may be between 200 and 600 μm depending on the application. Insulation layer 3 may be applied on conductive core 2 by means of extrusion and completely surrounds and is preferably in direct contact with conductive core 2.

[0050] Twisted pair 1 is surrounded by first shielding layer 4 defining first space 5 between first shielding layer 4 and twisted pair 1. From Figure 1 its clear that first space 5 basically consists of two distinct areas and as such first space 5 corresponds to the space enclosed by shielding layer 4 minus the space occupied by twisted pair 1. In the embodiment of Figure 1 shielding layer 4 is regarded as surrounding single twisted pair 1 directly.

[0051] According to the present invention a water blocking compound (not shown) is present in first space 5. In an exemplary embodiment the water blocking compound is a hotmelt adhesive marketed under the brand name INSTANT-FLEX X47 by National Starch & Chemical. This hotmelt material has proven to effectively block water and provide mechanical stability for cable element 10. In addition this hotmelt material is relatively easy to peel off by hand when an end of cable element 10 needs to be spliced or connectorised in the field. No solvent is necessary.

[0052] Figure 2 shows a data transmission cable 20 consisting of four cable elements 10 according to the present invention surrounded by second shielding layer 12. Cable elements 10 may be laid in parallel or may be stranded around each other either in the form of a helix or in an SZ configuration as known per se. Data transmission cable 20 is not restricted to the specific number of four cable elements 10, but any number can be used, e.g. two, four or even twenty cable elements 10 can be present within second shielding layer 12. In addition data transmission cable 20 can be grouped together with other data transmission cables 20 forming a communication

cable (not shown). Such a communication cable may comprise a central strength member wherein several data transmission cables 20 are stranded around in the form of a helix or in an SZ configuration, and eventually surrounded by an outer plastic sheath. Within such a communication cable the number of cable element 10 present in these data transmission cables 20 may differ from data transmission cable 20 to data transmission cable 20

[0053] Second shielding layer 12 may be in the form of a tape that has been wrapped around cable elements 10. In an alternative embodiment second shielding layer 12 in the form of a tape may be folded in longitudinal direction so as to form a tube like structure. Second shielding layer 12 comprises a conductive material, such as a metal and may be in the form of a braid of relative thin metal threads, for example made of copper.

[0054] Second shielding layer 12 and cable elements 10 are surrounded by outer sheath 11. Outer sheath 11 may be of a polymer material or a polymer compound comprising a polymer material such as polyethylene, polypropylene, ethylene-propylene copolymers, polyvinylchloride, polyurethane. In the embodiment shown in Figure 2, second shielding layer 12 is positioned tightly against the inner surface of outer sheath 11. It has to be understood that other configurations can also be envisaged which embodiments allow a certain radial distance between second shielding layer 12 and the inner wall of outer sheath 11.

[0055] Outer sheath 11 defines a second space 13 between an inner surface of outer sheath 11 and an outer surface of cable elements 10. Second space 13 corresponds to the space enclosed by outer sheath 11 minus the space occupied by cable elements 10 minus the space occupied by second shielding layer 12, if present.

[0056] Second space 13 may contain further water blocking and/or water swellable materials (not shown).

[0057] Figure 3 schematically shows a production line for use in a method for manufacturing of the cable elements according to the present invention.

[0058] First shielding layer 4 in the form of a tape is combined with one single twisted pair 1 and fed to die 30. By means of die 30 a water blocking compound is applied on the combined first shielding layer 4 and twisted pair 1. After application of the water blocking compound in die 30 the combined first shielding layer 4, twisted pair 1 and water blocking compound is fed to a folding device or folding die 31. In folding device 31 the tape forming first shielding layer 4 is folded in such a manner that a cable element 10 is obtained, wherein twisted pair 1 and the water blocking compound are surrounded by first shielding layer 4, wherein the water blocking compound is present in the first space created by the first shielding layer 4 and the twisted pair 1. It should be understood that the present invention is not limited to a first shielding layer manufactured in this way and that other methods known in the art may be applied.

[0059] Several production lines as described above may be operated in parallel for simultaneous manufac-

turing of several cable elements 10. The cable elements 10 thus manufactured may then be combined in parallel, helix or SZ configuration, optionally provided with a second shielding layer 12, water blocking and/or water swellable materials and finally provided with outer sheath 11 by means of extrusion so as to form data transmission cable 20.

10 Claims

1. Cable element for high frequency data transmission comprising one single twisted pair of insulated electrical conductors surrounded by a first shielding layer thereby forming a first space between said single twisted pair and an inner surface of said first shielding layer, **characterised in that,** at least part of said first space comprises a water blocking compound.
2. Cable element according to claim 1 wherein the water blocking compound has a relative dielectric permittivity E lower than or equal to 4, preferably lower than or equal to 3, at the frequency and temperature at which the cable element is operated.
3. Cable element according to one or more of the preceding claims 1-2 wherein the water blocking compound has a dissipation factor D lower than or equal to 0.001, at the frequency at which the cable element is operated.
4. Cable element according to one or more of the preceding claims 1-3 wherein the water blocking compound is a hotmelt, more preferably a hotmelt adhesive.
5. Cable element according to claim 4 wherein the hotmelt adhesive is an elastomer-based hotmelt adhesive.
6. Cable element according to one or more of the preceding claims 1-5 wherein the shielding layer is at least partly in contact with the single twisted pair of insulated electrical conductors.
7. Cable element according to one or more of the preceding claims 1-6 wherein the first shielding layer comprises an electrically conductive material, preferably metal.
8. Cable element according to one or more of the preceding claims 1-7 wherein the water blocking compound completely fills the first space along the length of the cable element.
9. Data transmission cable comprising at least one cable element according to any one or more of claims

1-8 wherein said at least one cable element is surrounded by an extruded outer sheath, the outer sheath defining a second space between an inner surface of the outer sheath and an outer surface of the at least one cable element.

5

10. Data transmission cable according to claim 9 further comprising a second shielding layer surrounding the at least one cable element, wherein said second shielding layer is surrounded by the outer sheath. 10
11. Data transmission cable according to one or more of the preceding claims 9-10 wherein at least one water swellable material and/or at least one water blocking material is present in said second space. 15
12. Data transmission cable according to one or more of preceding claims 9-11 operating at a frequency of at least 1 MHz. 20
13. Data transmission cable according to one or more of preceding claims 9-12 operating at a frequency in a range from 100 to 1000 MHz.
14. Data transmission cable according to one or more of the preceding claims 9-13 wherein the cable does not contain strengthening elements. 25
15. Use of the data transmission cable according one or more of preceding claims 9-14 for transmission of data under outdoor conditions. 30

35

40

45

50

55

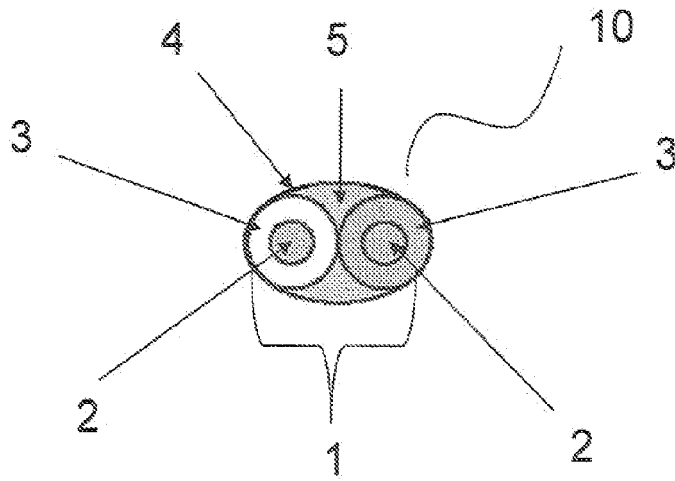

Figure 1

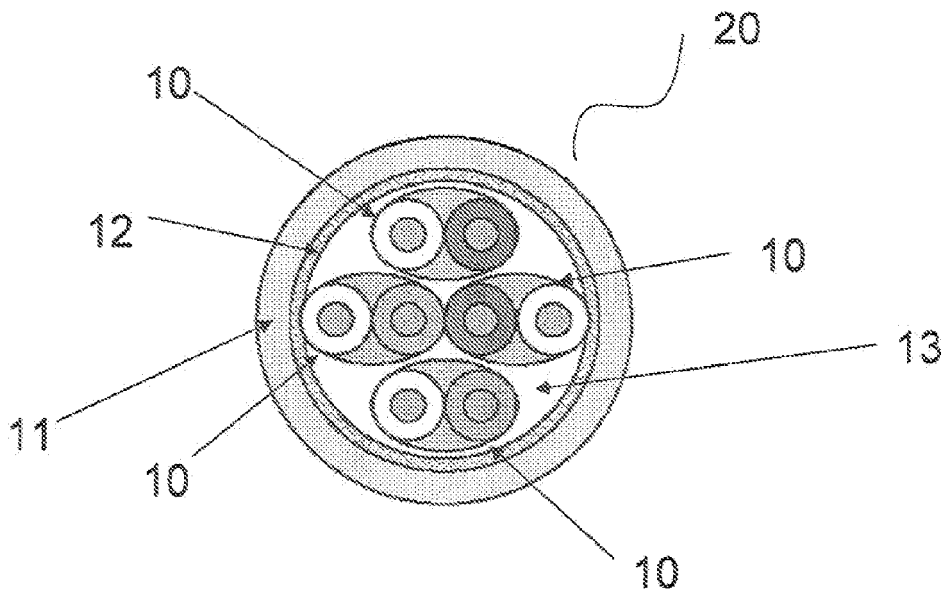

Figure 2

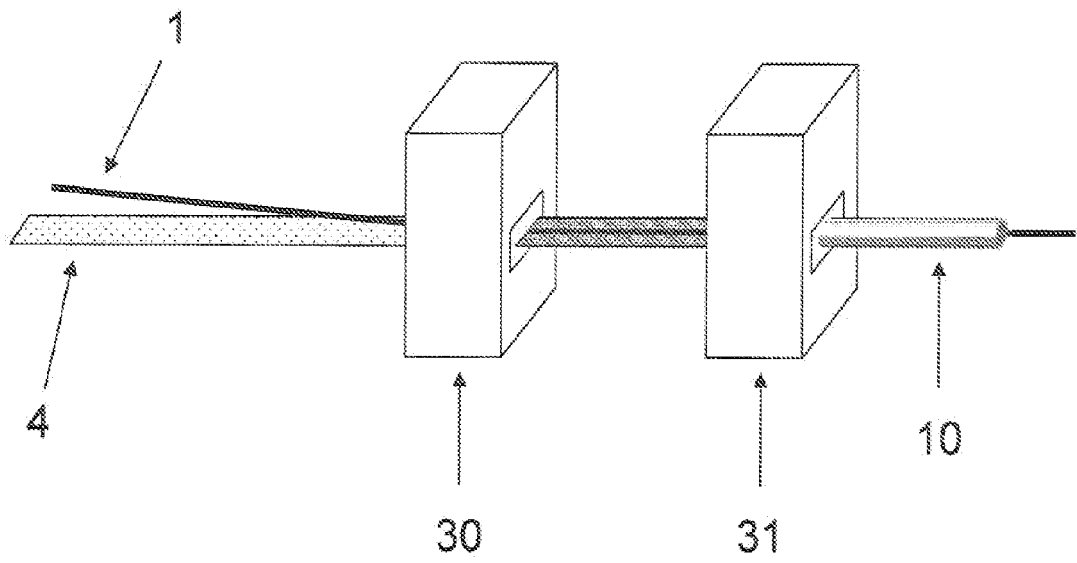

Figure 3

REFERENCES CITED IN THE DESCRIPTION

This list of references cited by the applicant is for the reader's convenience only. It does not form part of the European patent document. Even though great care has been taken in compiling the references, errors or omissions cannot be excluded and the EPO disclaims all liability in this regard.

Patent documents cited in the description

- EP 0572173 A **[0002]**
- EP 0586158 A **[0003]**
- GB 2164198 A **[0004]**
- US 6686537 B **[0005]**
- US 6815611 B **[0005]**
- US 20050077066 A **[0006]**
- US 2006004896 A **[0032]**
- WO 2006105166 A **[0032]**