

(12) **UK Patent Application** (19) **GB** (11) **2 218 401** (13) **A**
 (43) Date of A publication 15.11.1989

(21) Application No 8811125.7

(22) Date of filing 11.05.1988

(71) Applicant
S P Chemical Kabushiki Kaisha
 (Incorporated in Japan)
 95-5 Hijiriisshiki, Shizuoka-shi, Shizuoka-ken, Japan

(72) Inventor
Masao Enzu

(74) Agent and/or Address for Service
Appleyard Lees & Co
 15 Clare Road, Halifax, West Yorkshire, HX1 2HY,
 United Kingdom

(51) INT CL'
B65D 30/08 81/14

(52) UK CL (Edition J)
B8K KWX K2K1 K2M
A5R RBP RFB R6
B8P PE2C

(56) Documents cited
GB 1233701 A **GB 0943095 A** **GB 0911158 A**
US 4465188 A **US 4384602 A** **US 4323586 A**
US 4262801 A **US 4240556 A** **US 4155453 A**

(58) Field of search
 UK CL (Edition J) **B8K KAD KFD KWX**
 INT CL' **B65D**

(54) **Improvements in or relating to packages**

(57) A package, e.g. for a breakable article, in the form of a bag 1 or a sleeve 4 for placing in a box, is comprised of double-walled film material, the sealed space between the two film layers being fillable with a gas or liquid via a stopper 2. The invention is also applicable to water filled wet compresses and stanching and gyps for injuries.

FIG. 1

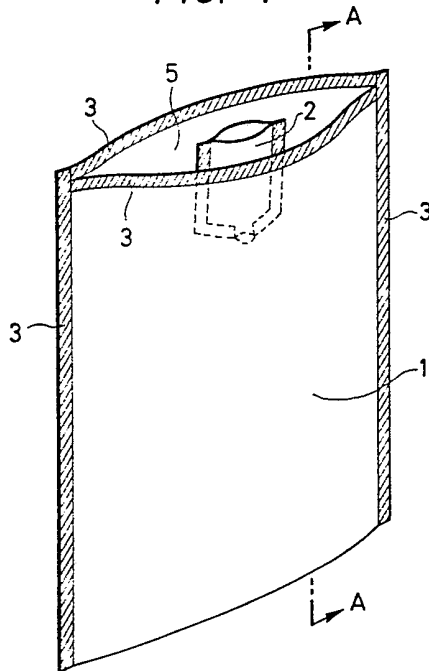
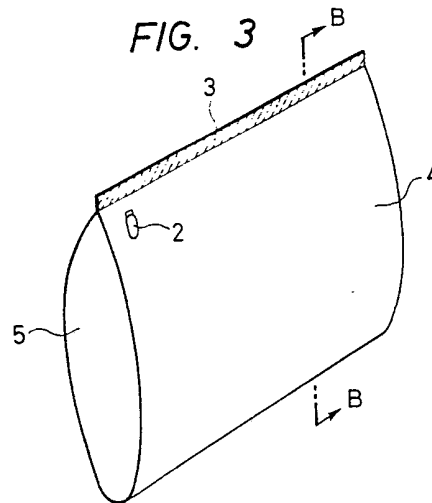

FIG. 3



GB 2 218 401 A

1/1

FIG. 1

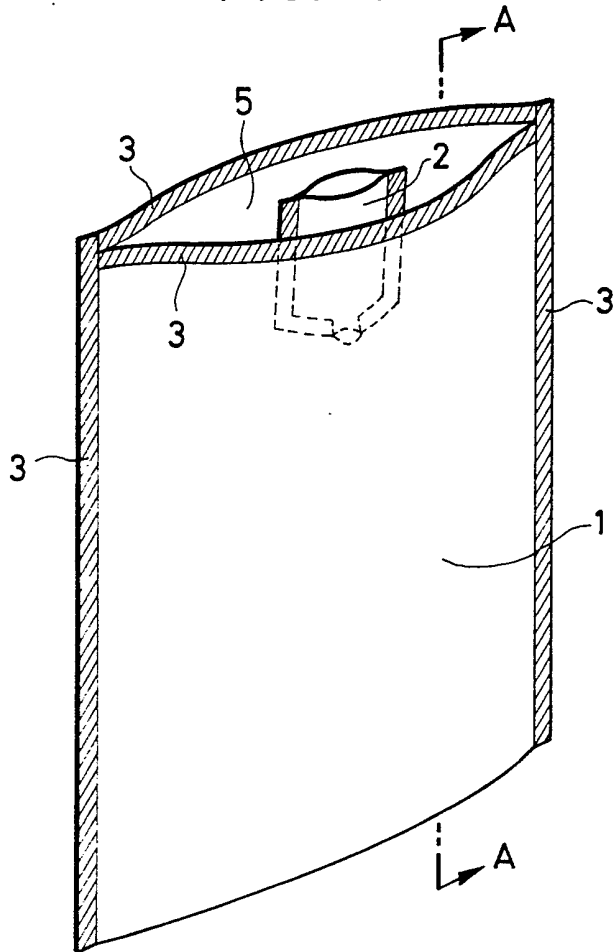

FIG. 2

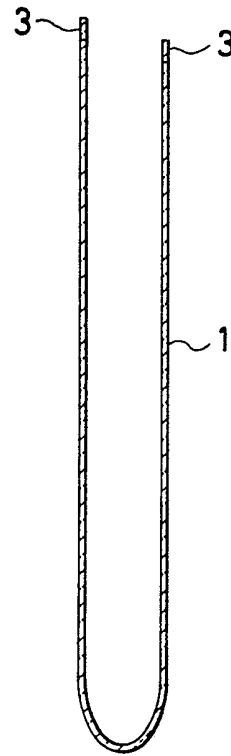

FIG. 3

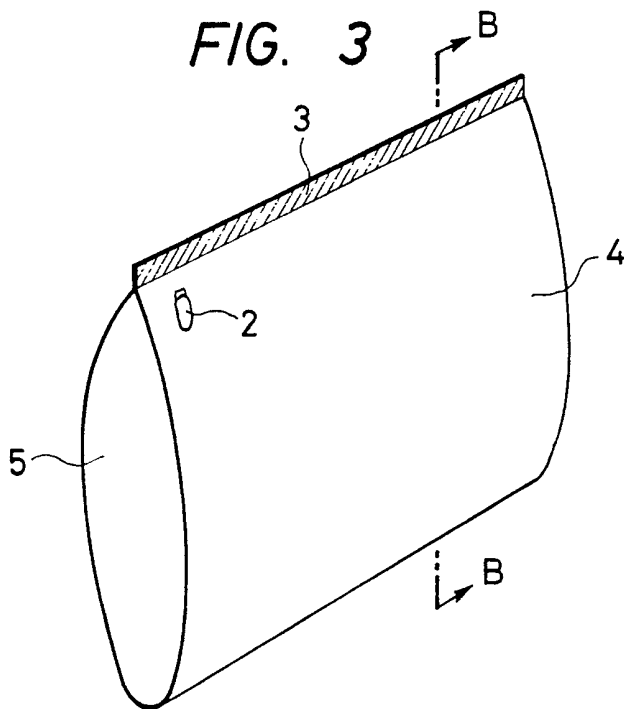
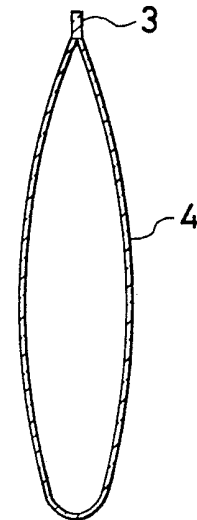

FIG. 4



IMPROVEMENTS IN OR RELATING TO PACKAGES.

BACKGROUND OF THE INVENTION

Field of the Invention

The present invention relates to packages and methods of packaging and in particular, although not exclusively to packages designed to accommodate articles which are easy to break or have complicated shapes or contours.

Statement of the Prior Art

Normally, articles are accommodated in corrugated cardboard boxes, containers and the like, which are all formed into a rectangular shape, except for special ones adapted for loading (unloading) and stability purposes.

Articles can take on various forms, and are often accommodated in the associated packages with a lot of gaps which have to be stopped with a filling material. Although depending upon the shape of the articles to be accommodated, a filling material larger in bulk volume than the article to be accommodated may be needed.

The filling material is usually light in weight, and their transportation and storage cost so much. Easy-to-break or expensive articles are now accommodated at increased wrapping costs in containers formed of styrol, etc., following their contours.

Thus, a simple replacement to the filling material has been desired.

SUMMARY OF THE INVENTION

In view of the foregoing, the present invention provides a package arrangement of a double structure in which a gas is poured in an internal space defined by a two-folded film, whereby the article accommodated is suspended in a shrunk state at the middle portion by an external pressure applied on the inner film.

According to one aspect of the present invention a package includes opposed sides, each side being comprised by a pair of films of flexible or soft material with means being provided for enabling fluid to be introduced into, or discharged from a sealed space defined between each of the pair of films.

The means for enabling fluid to be introduced into, or discharged from the sealed space comprises stopper means. A single stopper means into which fluid may be introduced into, or discharged from the sealed space defined between each of the pair of films may be provided.

There may be a single sealed space common to the pair of films on the opposed sides.

The package may include a pair of closed sides, and one open end and one closed end. Alternatively the package may have open ends and closed sides.

The package may be formed by superposing one film on top of another and then bonding or sealing the four-ply portions at both ends of the sheets together. The sides of the superposed sheets at least may be bonded or sealed together prior to the four-ply ends being bonded

or sealed together.

According to a further aspect of the present invention, a package is provided in which two rectangular films, each formed of a flexible or soft material, are superposed upon each other with the upper and lower bond edges being in alignment, and the four-ply portions at both ends are bonded together to form a bag body of a double structure, said bag body being provided in its one portion with a stopper means for pouring or discharging a gas or liquid in or from an internal space defined by the two-ply film.

According to a further aspect of the present invention, a package in which two rectangular films, each formed of a flexible or soft material, are superposed upon each other with its both side ends being bonded together, thereby forming a tubular body, or a tube member formed of a flexible or soft material is folded on itself with its both open ends being bonded together in alignment, thereby forming a cylindrical body, each of said bodies being provided in its one portion with a stopper means for pouring or discharging a gas or liquid in or from an internal space defined by the two-ply film.

According to another aspect of the present invention, a method of packaging an article or articles includes locating the article or articles between opposed sides of a package, each side being comprised by a pair of films of flexible or soft material, and introducing fluid into a sealed space defined between each of the pair of films. The method may include introducing the fluid after the article or articles have been located between the opposed sides. The article or articles may

be located completely between the opposed sides of the package.

BRIEF DESCRIPTION OF THE DRAWINGS

The feature(s) of the present invention will become apparent from the following detailed description with reference to the accompanying drawings, which are given for the purpose of illustration alone, and in which:-

Figure 1 is a perspective view illustrating schematically one embodiment of the package according to the present invention.

Figure 2 is a sectional view taken along the line A-A of Figure 1,

Figure 3 is a perspective view illustrating schematically another embodiment of the package according to the present invention, and

Figure 4 is a sectional view taken along the line B-B of Figure 2.

DETAILED DESCRIPTION OF THE INVENTION

Reference will now be made to the embodiments illustrated.

Referring to Figure 1, a bag body generally shown at 1 is provided with a stopper means 2 and a bond edge area 3. Thus, the bag body 1 is provided at its one portion with the stopper means 2, on which any limitation is not imposed in connection with its

structure and mounting position.

For instance, the stopper means 2 may be formed of a flexible or soft material, as defined in Claim 2 of my copending application Serial No. 911,352/

Referring to Figure 3, a cylindrical body generally shown at 4 is provided with openings 5 on its both sides. After an article has been placed in the body 4 through each opening 5, a gas such as air is poured and filled therein through a stopper means 2. The gas filled exerts an external pressure to the inner film, so that the article is suspended at the middle of the body 4 in a manner similar to a vacuum packed one.

In use, the article is accommodated in the cylindrical body 4, while the gas is poured and filled therein through the stopper means 2, and the thus expanded body 4 is placed in, e.g., a corrugated cardboard container of a length equal to the outer diameter thereof.

As mentioned above, the articles can be closely fixed in place regardless of their shapes or contours, since air is used as the filling material. Especially because they are in a simple film form before use, the costs needed for their transportation and storage are much lower than the conventional.

Especially when it is desired to accommodate a precious article in the present package, while completely preventing it from contacting air for the purpose of avoiding its oxidation, a large portion of the opening in the package receiving that article is bonded together, leaving a small ventilation hole. Then, if the gas is

poured in the package through the stopper means, the air is discharged from within the package through that ventilation hole with the result that it is shrunk. Thus, the obtained effect is comparable to that achieved by vacuum-packing.

Once the articles has been accommodated in the package, usually, the opening(s) remains open, viz., need not be closed.

Alternatively, the present package may be used as the first-aid stanching and gyps material for injuries, or the wet-compress material for sprains, if it is filled with water. Thus, the present packages are applicable not only to industrial purposes but also to wide areas of dally life as represented by considerable cut-downs in the transportation and storage costs.

CLAIMS

1. A package including opposed sides, each side being comprised by a pair of films of flexible or soft material with means being provided for enabling fluid to be introduced into, or discharged from a sealed space defined between each of the pair of films.

2. A package as claimed in Claim 1 in which the means for enabling fluid to be introduced into or discharged from the sealed space comprises stopper means.

3. A package as claimed in Claim 2 in which there is a single stopper means into which fluid may be introduced into or discharged from the sealed space defined between each of the pair of films.

4. A package as claimed in any preceding claim in which there is a single sealed space common to the pair of films on the opposed sides.

5. A package as claimed in any preceding claim including a pair of closed sides and one open end and one end closed.

6. A package as claimed in any of Claims 1 to 4 including open ends and closed sides.

7. A package as claimed in any preceding claim which has been formed by superposing one film on top of another and then bonding or sealing the four-ply portions at both ends of the sheets together.

8. A package as claimed in Claim 7 in which the sides of the superposed sheets at least are bonded or

sealed together prior to the four-ply ends being bonded or sealed.

9. A package in which two rectangular films, each formed of a flexible or soft material, are superposed upon each other with the upper and lower bond edges being in alignment, and the four-ply portions at both ends are bonded together to form a bag body of a double structure, said bag body being provided in its one portion with a stopper means for pouring or discharging a gas or liquid in or from an internal space defined by the two-ply film.

10. A package in which two rectangular films, each formed of a flexible or soft material, are superposed upon each other with its both side ends being bonded together, thereby forming a tubular body, or a tube member formed of a flexible or soft material is folded on itself with its both open ends being bonded together in alignment, thereby forming a cylindrical body, each of said bodies being provided in its one portion with a stopper means for pouring or discharging a gas or liquid in or from an internal space defined by the two-ply film.

11. A package substantially as herein described with reference to, and as shown in Figures 1 and 2 or Figures 3 and 4 of the accompanying drawings.

12. A method of packaging an article or articles including locating the article or articles between opposed sides of a package, each side being comprised by a pair of films of flexible or soft material and introducing fluid into a sealed space defined between each of the pair of films.

13. A method as claimed in Claim 12 including introducing the fluid into the sealed space after the article or articles have been located between the opposed sides.

14. A method as claimed in Claim 12 or 13 in which the article or articles are located completely between the opposed sides of the package.

15. A method of packaging an article or articles substantially as herein described with reference to, or as shown in Figures 1 and 2 or Figures 3 and 4 of the accompanying drawings.

16. A method of packaging as claimed in any of Claims 12 to 15 using a package as claimed in any of Claims 1 to 11.