



- (51) International Patent Classification:
B60S 5/04 (2006.01)
- (21) International Application Number:
PCT/US2016/065117
- (22) International Filing Date:
6 December 2016 (06.12.2016)
- (25) Filing Language: English
- (26) Publication Language: English
- (30) Priority Data:
62/272,166 29 December 2015 (29.12.2015) US
- (71) Applicant: BRIDGESTONE AMERICAS TIRE OPERATIONS, LLC [US/US]; 535 Marriott Drive, Nashville, Tennessee 37214 (US).
- (72) Inventors: DUNCAN, Anthony B.; 1454 Fixler Road, Wadsworth, Ohio 44281 (US). BOTELLO, Sergio A.; 200 Guyler Lane, Del Rio, Texas 78840 (US).
- (74) Agents: JUPINA, Matthew W. et al.; 10 East Firestone Blvd., Akron, Ohio 44317 (US).
- (81) Designated States (unless otherwise indicated, for every kind of national protection available): AE, AG, AL, AM,

AO, AT, AU, AZ, BA, BB, BG, BH, BN, BR, BW, BY, BZ, CA, CH, CL, CN, CO, CR, CU, CZ, DE, DJ, DK, DM, DO, DZ, EC, EE, EG, ES, FI, GB, GD, GE, GH, GM, GT, HN, HR, HU, ID, IL, IN, IR, IS, JP, KE, KG, KN, KP, KR, KW, KZ, LA, LC, LK, LR, LS, LU, LY, MA, MD, ME, MG, MK, MN, MW, MX, MY, MZ, NA, NG, NI, NO, NZ, OM, PA, PE, PG, PH, PL, PT, QA, RO, RS, RU, RW, SA, SC, SD, SE, SG, SK, SL, SM, ST, SV, SY, TH, TJ, TM, TN, TR, TT, TZ, UA, UG, US, UZ, VC, VN, ZA, ZM, ZW.

- (84) Designated States (unless otherwise indicated, for every kind of regional protection available): ARIPO (BW, GH, GM, KE, LR, LS, MW, MZ, NA, RW, SD, SL, ST, SZ, TZ, UG, ZM, ZW), Eurasian (AM, AZ, BY, KG, KZ, RU, TJ, TM), European (AL, AT, BE, BG, CH, CY, CZ, DE, DK, EE, ES, FI, FR, GB, GR, HR, HU, IE, IS, IT, LT, LU, LV, MC, MK, MT, NL, NO, PL, PT, RO, RS, SE, SI, SK, SM, TR), OAPI (BF, BJ, CF, CG, CI, CM, GA, GN, GQ, GW, KM, ML, MR, NE, SN, TD, TG).

Published:

— with international search report (Art. 21(3))

(54) Title: AIR DISTRIBUTION SYSTEM FOR RAPID TIRE INFLATION

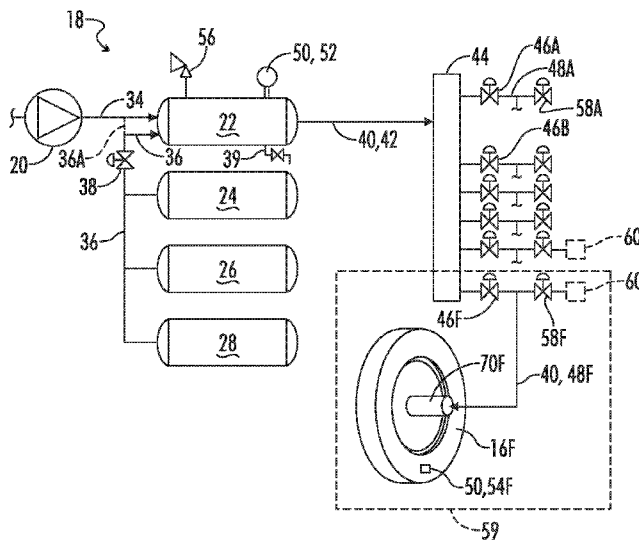

FIG. 3

(57) Abstract: A tire inflation system is provided for a vehicle supported by a plurality of inflatable tires. The system includes a compressor carried on the vehicle, and an air storage tank carried on the vehicle and connected to the compressor for storing compressed air. A plurality of automatically operable fill valves are provided, each fill valve being associated with a respective one of the tires so that each tire is communicated with the air storage tank via a separate one of the fill valves to increase inflation pressure in the tire when its respective fill valve is in an open position. A controller is operably associated with all of the fill valves. The controller has a multiple tire rapid inflation mode in which the fill valves associated with at least two of the tires are maintained in their open positions for an initial period until pressure in the air storage tank and the at least two tires substantially equalizes, and for a subsequent period during which the compressor provides additional inflation air to the at least two tires.

WO 2017/116628 A1

UNITED STATES PATENT APPLICATION

(PROVISIONAL 37 C.F.R. §1.53(c))

AIR DISTRIBUTION SYSTEM FOR RAPID TIRE INFLATION

BACKGROUND OF THE INVENTION

1. Field of the Invention

[0001]The present disclosure relates generally to a method and apparatus for adjusting air pressure within a tire. More particularly, but not by way of limitation, the system provides for the rapid change between a field ready pressure and a road ready pressure for large agricultural tires when the agricultural vehicles on which the tires are used move from a field environment to a road environment and vice versa.

2. Description of the Prior Art

[0002]Large self-propelled agricultural equipment such as a tractor, combine harvester or high clearance sprayer spends most of its operational time in or around a cultivated field. As a result, the tires of the equipment are often adapted to address common concerns arising from using heavy machinery over a cultivated field. One of the common concerns is soil compaction. As large equipment travels over a given field, the soil beneath the equipment's tires will be compacted to increase in density. This soil compaction may be harmful to the production or yield of the field. As soil compaction increases, the yield will often decrease. In order to combat this problem, it is common for equipment operators to reduce the air pressure of the tires when the equipment is in the field. Experience has shown that a reduced tire air pressure can reduce the level of soil compaction in the field. As a result it can also increase the production and efficiency of the field.

[0003]While this reduced tire air pressure may be preferable in the field environment, an elevated tire pressure is still preferable when the equipment is traveling over a typical paved road. The elevated tire pressure allows each tire to roll more efficiently and achieve a higher maximum velocity. With many users being forced to transport their large agricultural equipment extended distances from one field to another, speed and efficiency during transport is important. However, the time needed to inflate or deflate a typical tire is often a hindrance to the ability to rapidly and efficiently move the agricultural equipment from the field environment to the road environment.

[0004]What is needed then is an improved tire inflation system addressing these concerns.

SUMMARY OF THE INVENTION

[0005] In one embodiment a tire inflation system is provided for a vehicle supported by a plurality of inflatable tires. The system includes a compressor carried on the vehicle, and an air storage tank carried on the vehicle and connected to the compressor for storing compressed air. A plurality of automatically operable fill valves are provided. Each fill valve is associated with a respective one of the tires so that each tire is communicated with the air storage tank via a separate one of the fill valves to increase inflation pressure in the tire when its respective fill valve is in an open position. A controller is operably associated with all of the fill valves, the controller having a multiple tire rapid inflation mode in which the fill valves associated with at least two of the tires are maintained in their open positions for an initial period until pressure in the air storage tank and the at least two tires substantially equalizes, and for a subsequent during which the compressor provides additional inflation air to the at least two tires.

[0006] In another embodiment a method of rapid inflation of a plurality of tires of a vehicle is provided. The method may include the steps of:

- (a) providing on the vehicle a compressed air tank system;
- (b) providing on the vehicle an air compressor;
- (c) providing a plurality of automated fill valves, each fill valve being associated with a respective one of the tires so that each tire can be communicated with the air tank system via a separate one of the fill valves;
- (d) storing compressed air from the compressor in the air tank system at a storage pressure; and
- (e) under control of a multiple tire rapid inflation mode of a controller, opening the fill valves associated with at least two of the tires and maintaining the fill valves associated with the at least two tires in their open positions during an initial period until pressure in the air tank system and the at least two tires substantially equalizes, and during a subsequent period during which the compressor provides additional inflation air to the at least two tires.

[0007] The multiple tire rapid inflation mode may be configured such that during the subsequent period the compressor provides the additional inflation air to the at least two tires through the air storage tank.

[0008] The multiple tire rapid inflation mode may be an all tire rapid inflation mode in which all of the fill valves are maintained in their open positions for the initial period until pressure

in the air storage tank and all of the tires substantially equalizes, and for the subsequent period during which the compressor provides additional inflation air to all of the tires.

[0009] Preferably each of the fill valves is a non-throttling on-off valve selectively movable between a discrete open position and a discrete closed position.

[0010] The fill valves may be solenoid operated fill valves.

[0011] The controller may have a manual mode in which a human operator can separately control each of the fill valves to separately inflate each of the tires.

[0012] The system may include a plurality of tire pressure sensors, one of the tire pressure sensors being disposed in each of the tires, each tire pressure sensor being configured to wirelessly transmit pressure data, and the controller may be configured to receive the pressure data from the tire pressure sensors.

[0013] The system may include a plurality of automatically operable dump valves, each dump valve being associated with a respective one of the tires so that each tire is vented via a separate one of the dump valves to decrease inflation pressure in the tire when its respective dump valve is in an open position.

[0014] Each of the fill valves and each of the dump valves may be separate solenoid operated valves, with each tire having associated therewith one of the fill valves located in an inflation air line between the air storage tank and the respective tire, and with each of the dump valves being communicated with an open exhaust zone and with the air inflation line between the respective fill valve and the tire.

[0015] The controller may have an all tire rapid deflation mode in which all of the dump valves are initially in their open positions, and in which each separate dump valve is then closed when the inflation pressure in its respective tire drops to a set low pressure level.

[0016] The controller may include an input device configured such that a human operator can enter a low pressure setting and a high pressure setting into the controller. The controller may be configured in the multiple tire rapid inflation mode to maintain the fill valves associated with the at least two tires in their open positions until inflation pressure in the at least two tires reaches the high pressure setting.

[0017] The system may include a tank pressure sensor communicated with the air storage tank. The controller may be operably associated with the tank pressure sensor to receive signals indicative of air pressure in the air storage tank and the controller may be configured to control inflation pressure in the tires based upon the signals from the tank pressure sensor.

[0018] Each of the fill valves may be incorporated in a three-way valve having the open position, a dump position in which the respective tire is vented to decrease inflation pressure

in the tire, and a blocked position in which there is no flow of air to or from the tire through the three-way valve.

[0019]The system may include an inflation air main line connected to the storage tank, and a manifold connected to the inflation air main line. Each of the fill valves may be connected to the manifold so that each fill valve is communicated with the air storage tank through the manifold and the inflation air main line. The system may include a plurality of separate inflation air branch lines, each fill valve being communicated with its respective tire by one of the separate inflation air branch lines.

[0020]In one embodiment the inflation air main line may comprise one and only one tubular conduit communicating the air storage tank with the manifold.

[0021]The vehicle may include a tractor having at least first and second axles and a trailer having at least a third axle, wherein the compressor and air storage tank are carried on the tractor, and at least one of the fill valves is communicated with a tire of the tractor and at least one of the fill valves is communicated with a tire of the trailer.

[0022]The air storage tank system may include a main air storage tank and may further include an auxiliary air storage tank, both carried on the vehicle.

[0023]Numerous objects features and advantages of the present invention will be readily apparent to those skilled in the art upon a reading of the following disclosure when taken in conjunction with the accompanying drawings.

BRIEF DESCRIPTION OF THE DRAWINGS

[0024]Fig. 1 is a schematic plan view of a vehicle comprising a tractor and a trailer, and including a tire inflation system. The trailer may be an agricultural implement.

[0025]Fig. 2 is a schematic elevation view of the tractor of Fig. 1.

[0026]Fig. 3 is a schematic view of the compressor, the air storage tanks, the various supply and inflation lines, the fill and dump valves, and the connection thereof to a representative one of the tires.

[0027]Fig. 4 is a schematic illustration, similar to that portion of Fig. 3 contained in dashed lines, illustrating an alternative embodiment for the fill and dump valves. In the embodiment of Fig. 4 a single three-way valve replaces the separate fill valve and dump valve arrangement of Fig. 3.

[0028]Fig. 5 is a schematic illustration of the controller and its interconnection with the various sensors and control valves of Fig. 3.

[0029] Fig. 6 is a graphical representation of air pressures stored in the air storage tank and of inflation pressure provided to the tires as a function of time.

DETAILED DESCRIPTION

Definitions

[0030] Following are definitions of selected terms employed herein. The definitions include various examples and/or forms of components that fall within the scope of a term and that may be used for implementation. The examples are not intended to be limiting. Both singular and plural forms of terms may be within the definitions.

[0031] "Air" is understood to mean any inflating fluid suitable for use within a tire, including, but not limited to, gases containing some amount of nitrogen or oxygen. Consequently, "air pressure" is understood to mean the fluid pressure caused at least partially by the "air" contained within a body.

[0032] "Signal" may include any meaning as may be understood by those of ordinary skill in the art, including at least an electric or magnetic representation of current, voltage, charge, temperature, data or a state of one or more memory locations as expressed on one or more transmission mediums, and generally capable of being transmitted, received, stored, compared, combined or otherwise manipulated in any equivalent manner.

[0033] To the extent that the term "includes" or "including" is used in the specification or the claims, it is intended to be inclusive in a manner similar to the term "comprising" as that term is interpreted when employed as a transitional word in a claim. Furthermore, to the extent that the term "or" is employed (e.g., A or B) it is intended to mean "A or B or both." When the applicants intend to indicate "only A or B but not both" then the term "only A or B but not both" will be employed. Thus, use of the term "or" herein is the inclusive, and not the exclusive use. See, Bryan A. Garner, *A Dictionary of Modern Legal Usage* 624 (2d. Ed. 1995). Also, to the extent that the terms "in" or "into" are used in the specification or the claims, it is intended to additionally mean "on" or "onto." Furthermore, to the extent the term "connect" is used in the specification or claims, it is intended to mean not only "directly connected to," but also "indirectly connected to" such as connected through another component or multiple components.

[0034] Terms such as "a," "an," and "the" are not intended to refer to only a singular entity, but rather include the general class of which a specific example may be used for illustration. The terminology herein is used to describe specific embodiments of the invention, but their usage does not delimit the invention, except as set forth in the claims.

[0035] Referring now to Figs. 1 and 2 a vehicle 10 is shown which may include a tractor 12 and a trailer 14. The trailer 14 may be a trailer for hauling goods, or it may be another agricultural implement including but not limited to freewheeling agricultural implements including corn planters, tillage equipment, disc implements, rippers, field cultivators, air seeders and the like.

[0036] The tractor 12 includes first and second front tires 16A and 16B associated with a front axle 17, and first and second rear tires 16C and 16D associated with a rear axle 19. The trailer may include first and second trailer tires 16E and 16F associated with a trailer axle 21. It will be understood that the vehicle 10 may include other arrangements and may include more than the six tires shown or less.

[0037] A tire inflation system 18 is mounted on the vehicle 10, and is schematically illustrated in Fig. 3. The tire inflation system includes a compressor 20 carried on the tractor 12. A main air storage tank 22 and a plurality of auxiliary air storage tanks 24, 26 and 28 are also carried on the tractor 12. As best seen in Fig. 2, the air storage tanks may be mounted on a roof 30 of the tractor 12 with a mounting bracket 32. A compressed air supply main line 34 communicates the compressor 20 with the main air storage tank 22. A compressed air supply auxiliary line 36 is shown in Fig. 3 to communicate the auxiliary air storage tanks 24, 26 and 28 with the main air storage tank 22. Optionally, as shown in dashed lines at 36A in Fig. 3, the compressed air supply auxiliary line 36 could be connected to the compressed air supply main line 34. In general, the compressed air supply auxiliary line can be described as being communicated with at least one of the compressed air supply main line 34 and the main air storage tank 22.

[0038] An automated shut off valve 38 is disposed in the compressed air supply auxiliary line 36.

[0039] A condensate drain 39 may also be provided on each of the tanks as shown in Fig. 3 for main storage tank 22.

[0040] An inflation air line 40 communicates the main air storage tank 22 with at least one of the tires 16A-16F. The inflation air line 40 may be described as including an inflation air main line 42 which connects the main air storage tank 22 to a manifold 44.

[0041] In the embodiment illustrated in Fig. 3, the inflation air main line 42 is illustrated as comprising one and only one tubular conduit 42 communicating the main air storage tank 22 with the manifold 44. Optionally, in some embodiments the inflation air main line 42 could comprise multiple tubular conduits communicating one or more storage tanks with the manifold 44, or with multiple manifolds associated with the various fill valves.

[0042] A plurality of automatically operable fill valves 46A-46F are connected to the manifold 44. Each fill valve is communicated with a respective one of the tires 16A-16F by a separate inflation air branch line 48A-48F. The inflation air branch lines 48A-48F may be considered part of the inflation air line 40.

[0043] An inflation pressure sensor 50 is arranged to detect an inflation pressure provided to the at least one of the tires 16A-16F. In one embodiment, the inflation pressure sensor 50 includes a tank pressure gauge 52 communicated with the main air supply tank 22 or optionally communicated with the inflation air main line 42. Optionally, the inflation pressure sensor 50 may include a plurality of tire pressure sensors 54A-54F, each of the tire pressure sensors 54 being disposed in one of the tires 16A-16F, with each tire pressure sensor configured to wirelessly transmit pressure data. The tire pressure sensors 54 may be conventional Tire Pressure Monitoring System (TPMS) sensors.

[0044] The inflation air branch lines such as 48F communicate air to their associated tires such as 16F via rotary unions such as union 70F schematically illustrated in Fig. 3.

[0045] Preferably, the rotary unions 70 are communicated with the interior cavities of their respective tires 16 via a pilot type inflation valve. Such valves communicate with two pneumatic circuits of the rotary union 70. A large bore circuit provides a flow path for inflation air, and a smaller bore circuit supplies pilot air pressure to a pilot valve of the inflation valve. The pilot valve is located in the inflation valve and acts to separate the tire cavity from the outside. When the pilot circuit is unpressurized, the inflation valve is closed and the tire 16 cannot leak through the inflation valve plumbing. Pressurizing the pilot valve of the inflation valve forces the inflation valve to open so that the tire cavity is connected to the inflation path through the rotary union 70. The advantage of this arrangement is that the tire cannot leak due to damage to the pressure tubing and the rotary union 70 can remain unpressurized most of the time, thus improving seal life. Such pilot actuated inflation valves are particularly useful when using internal TPMS sensors such as 54A-54F.

[0046] Thus, each of the fill valves 46A-46F is communicated with the main air storage tank 22 through the manifold 44 and the inflation air main line 42, and each fill valve is communicated with its respective tire by one of the separate inflation air branch lines 48A-48F.

[0047] A pressure relief valve 56 may be mounted on the main air storage tank 22.

[0048] In Fig. 3, the details of the valving associated with tire 16F are schematically illustrated within the dashed box 59. The details associated with the valving corresponding to each of the other tires is similarly constructed. As noted, the fill valve 46F is an automated fill valve and it

communicates its associated tire 16F with the main air storage tank 22 when the fill valve 46F is in an open position. The fill valve 46F may be a solenoid operated valve having an open position and a closed position. The fill valve 46F may be described as a non-throttling on-off valve selectively moveable between a discrete open position and a discrete closed position.

[0049] Also associated with each of the tires is an automatically operable dump valve 58A-58F, respectively. Each of the dump valves such as 58F may also be a separate solenoid operated valve which may be described as a non-throttling on-off valve selectively moveable between a discrete open position and a discrete closed position. One example of valves suitable for use as fill valves 46A-F and dump valves 58A-F is an Air Engine 4F valve available from AirBagIt.com. Each of the dump valves such as 58F is connected to its associated inflation air branch line such as 48F between its associated fill valve 46F and tire 16F. The dump valve 58F is also communicated with an open exhaust zone 60 which may for example be the atmosphere.

[0050] Thus, when fill valve 46F is open and dump valve 58F is closed, compressed air may be provided to the tire 16F to further inflate the same from the compressed air storage tank 22. To deflate the tire 16F, the fill valve 46F is closed and the dump valve 58F is opened.

[0051] Thus, each of the tires 16A-F is associated with a respective one of the dump valves 58A-58F, so that each tire is vented to an open exhaust zone 60 to decrease inflation pressure in the tire when its respective dump valve 58A-58F is in an open position.

[0052] Fig. 4 shows an alternative version of the structure within the dashed box 59 of Fig. 3, in which a single three-way valve 62F has been substituted for the arrangement of separate fill valve 46F and dump valve 58F described above regarding Fig. 3.

[0053] In Fig. 4, the three-way valve 62F is illustrated schematically as having an open position 64 in which the manifold 44 is communicated with the tire 16F, a dump position 66 in which the respective tire 16F is vented to open exhaust zone 60 to decrease inflation pressure in the tire, and a blocked position 68 in which there is no flow of air to or from the tire 16F through the three-way valve 62F.

The Control System

[0054] Referring now to Fig. 5, a control system for the tire inflation system 18 is schematically illustrated. A controller 72 is operably associated with all of the fill valves 46A-46F, the dump valves 58A-58F, the automated shut off valve 38, and various other components of the tire inflation system 18.

[0055] Controller 72 includes a processor 74, a computer readable memory medium 76, a data base 78 and an input/output module or control panel 80 having a display 82.

[0056] The term “computer-readable memory medium” as used herein may refer to any non-transitory medium 76 alone or as one of a plurality of non-transitory memory media 76 within which is embodied a computer program product 84 that includes processor-executable software, instructions or program modules which upon execution may provide data or otherwise cause a computer system to implement subject matter or otherwise operate in a specific manner as further defined herein. It may further be understood that more than one type of memory media may be used in combination to conduct processor-executable software, instructions or program modules from a first memory medium upon which the software, instructions or program modules initially reside to a processor for execution.

[0057] “Memory media” as generally used herein may further include without limitation transmission media and/or storage media. “Storage media” may refer in an equivalent manner to volatile and non-volatile, removable and non-removable media, including at least dynamic memory, application specific integrated circuits (ASIC), chip memory devices, optical or magnetic disk memory devices, flash memory devices, or any other medium which may be used to stored data in a processor-accessible manner, and may unless otherwise stated either reside on a single computing platform or be distributed across a plurality of such platforms. “Transmission media” may include any tangible media effective to permit processor-executable software, instructions or program modules residing on the media to be read and executed by a processor, including without limitation wire, cable, fiber-optic and wireless media such as is known in the art.

[0058] The term “processor” as used herein may refer to at least general-purpose or specific-purpose processing devices and/or logic as may be understood by one of skill in the art, including but not limited to single- or multithreading processors, central processors, parent processors, graphical processors, media processors, and the like.

[0059] The controller 72 receives input data from the various sensors such as tank pressure sensor 52 and the various tire pressure sensors 54A-54F, all of which are schematically shown in Fig. 5. The controller may receive various other inputs regarding other operating parameters of the vehicle 10.

[0060] Based upon various operational modes which may be defined by the computer programming product 84 the controller 72 generates various control signals which may be communicated to the automated shut off valve 38, the automated fill valves 46A-46F, and the automated dump valves 58A-58F as schematically illustrated via dashed communication lines 90, 91 and 93 in Fig. 5. Any of the communication lines 90, 91 and 93 may be hard wired or they may be wireless communication.

[0061] In order to provide for rapid inflation of the tires, two sources of compressed air are provided, namely the compressed air tank system including main air storage tank 22 and auxiliary storage tanks 24, 26 and 28, and a second air source, namely the compressor 20.

[0062] Depending upon the relative volumes of the tires, the tank system, and the output capacity of the compressor, the relative portions of the tire filling capacity provided by the stored compressed air in the tank system as compared to the additional compressed air provided over time from the compressor will vary.

[0063] For a given set of tires, and for a desired fill time between a given low pressure and high pressure, the selection of storage tank capacity and compressor output rate will determine the relative contributions to inflation capabilities from the stored compressed air and the additional compressed air.

[0064] Typically, the initial inflation boost provided from stored compressed air when the fill valves 46A-46F are open will equalize with the tires within a few seconds, and then the additional time required for the compressor to bring the inflation pressure up to the desired final pressure will depend on the output rate of the compressor 20.

[0065] The tire inflation system 18 described above is particularly well adapted for a rapid inflation of tires from a low pressure level to a high pressure level, such as for example to increase the inflation pressure of the tires of an agricultural vehicle from the low pressure level at which it preferably operates in the agricultural field, to a higher pressure level suitable for moving the agricultural vehicle along the public highways to a different location. To that end, the controller 72 can be operated in any one of several different operational modes which take advantage of the functional features of the tire inflation system 18 described above in order to increase the speed at which a given system can inflate the tires of an agricultural vehicle. Several such modes of operation are described below, emphasizing various features of the tire inflation system 18. These various modes may be used individually or in combination. In general all of the modes described below can be described as rapid inflation modes, and each takes advantage of the ability of the system 18 to initially communicate stored compressed air from a storage tank to the tire or tires being inflated to raise the pressure in the tires from an initial level to an intermediate level, and to subsequently continue to increase the pressure in the tires from the intermediate level achieved with the stored compressed air to a final level achieved with the assistance of additional compressed air coming from the compressor 20.

Rapid Inflation Mode 1 - Isolation of Auxiliary Storage Tanks

[0066] A first rapid inflation mode takes advantage of the presence of the automated shut off valve 38 in the compressed air supply auxiliary line 36, and its ability to isolate the auxiliary compressed air storage tanks 24, 26 and 28 from the compressor 20 after those auxiliary storage tanks have been utilized to initially boost the inflation pressure of the tire or tires being inflated.

[0067] Fig. 6 is a graphical representation of this rapid inflation mode and it shows time on the horizontal scale and pressure on the vertical scale. The solid line curve is representative of the pressure in the main storage tank 22, and the dashed line curve is representative of the pressure in the tire or tires 16 being inflated.

[0068] Beginning at time T_0 the pressure in the tire or tires being inflated is represented as $PTIRE_{0,1}$ and that pressure is at the low pressure level for the tires at which they would be operating in the agricultural field. At time T_0 the pressure in the main storage tank 22 is at $PTANK_{0,1}$ which is the storage pressure in the tank 22 and also within the auxiliary tanks 24, 26 and 28. The pressure in the storage tanks and particularly main storage tank 22 may be monitored by the tank pressure sensor 52 which communicates with the controller 72.

[0069] If separate TPMS sensors 54A-54F are used, the controller 72 may be configured to receive pressure data from the tire pressure sensors 54 and to use that as an indication of both tank pressure and tire pressure instead of the signals from tank pressure sensor 52. Furthermore, the controller 72 may base its actions on a combination of the pressure signals from tank pressure sensor 52 and tire pressure sensors 54.

[0070] At time T_0 , the automated shut off valve 38 is open so that the storage capacity of auxiliary compressed air tanks 24, 26 and 28 is added to that of the main compressed air storage tank 22 to define a storage volume of the storage tank system comprised of all of the operable storage tanks combined.

[0071] At time T_1 one or more of the fill valves 46A-46F are opened to communicate the storage tank system with one or more of the tires 16A-16F to be inflated. In a relatively short interval of time, such as for example a few seconds, in the time interval from T_1 to T_2 , the pressure in the tank storage system will drop and the pressure in the tire or tires being inflated will rise until they are substantially equalized at a pressure shown as $PTANK_2/PTIRE_2$ at time T_2 . During this operation, the compressor 20 will be on and will be adding additional air to the compressed air storage tank system. Once the pressure in main storage tank 22 and the tire or tires being inflated equalizes, then the pressure in both the storage tank system and the tires will begin to gradually increase as seen in both the solid line curve 86 and the dashed curve 88 to the right of time T_2 .

[0072] The controller 72 is monitoring the pressure in the tank 22 via tank pressure sensor 52 and can determine when the pressure in tank 22 has reached its lowest level and has begun to increase, indicating that the low point in the curve 86 has been reached. At that time, the controller 72 sends a control signal to automated shut off valve 38 via control line 90 seen in Fig. 5 to close the valve 38 thereby isolating the auxiliary tanks 24, 26 and 28 from the compressor 20 while the compressor 20 continues to provide additional compressed air to the main storage tank 22 and thus to the tire or tires being inflated.

[0073] By isolating the auxiliary storage tanks 24, 26 and 28, which may be described as a majority portion of the storage volume of the tank system, the speed with which the tire or tires being inflated can be raised to their desired final pressure $PTIRE_3$ is increased, because the compressor 20 is not required to raise the pressure within the auxiliary storage tanks to the higher pressure level.

[0074] Thus again with reference to Fig. 6, the tank storage pressure shown by curve 86 and the tire inflation pressure shown by dashed curve 88 will more gradually rise and remain substantially equal as shown in Fig. 6 from time T_2 to time T_3 .

[0075] At time T_3 , when the controller 72 detects that the pressure $PTIRE_3$ has been achieved in the tire or tires being inflated, then the operative fill valves 44A-46F will be closed, and the shut off valve 38 will be reopened, so that the compressor 20 may repressurize the entire tank system including main tank 22 and auxiliary tanks 24, 26 and 28 back to the tank storage pressure $PTANK_{0,1}$. This is schematically represented by the portion of solid line curve 86 between times T_3 and T_4 in Fig. 6.

[0076] In one aspect, the rapid inflation mode just described with regard to Fig. 6 can be described as being performed by the controller 72 having a rapid inflation mode configured to initially communicate stored compressed air from both the main air storage tank 22 and the auxiliary storage tanks 24, 26 and 28 to the tire or tires 16 being inflated, and to then close the automated shut off valve 38 so that additional compressed air from the compressor 20 is communicated to the tire or tires being inflated without repressurizing the auxiliary air storage tanks 24, 26 and 28.

[0077] This can also be described as closing the automated shut off valve 38 after pressure in the main air storage tank 22 and the tire or tires being inflated substantially equalizes as shown by the intersection of curves 86 and 88 at time T_2 in Fig. 6.

[0078] As previously noted, the controller 72 includes an input/output module 80, which may be more generally described as an input device configured such that a human operator can enter a low pressure setting such as the pressure $PTIRE_{0,1}$ in Fig. 6, and a high pressure setting such as

the pressure $PTIRE_3$ in Fig. 6, into the controller 72. Thus the rapid inflation mode of controller 72 just described is configured such that the automated shut off valve remains closed and the fill valves 46 associated with the tire or tires being inflated remain open, until the inflation pressure in the tire or tires being inflated reaches the high pressure setting $PTIRE_3$.

[0079] It is noted that in the system illustrated in Fig. 4, the closure of the automated shut off valve 38 isolates the auxiliary tanks from the compressor 20, but the compressor 20 still communicates with the tire 16 via the main storage tank 22. Although it is possible in an alternative embodiment of the invention to also have the compressor 20 also bypass the main compressed air storage tank 22, it is generally preferable to keep some storage capacity as represented by the main air storage tank 22 in order to provide some surge protection to the pneumatic system and to prevent short cycling of the compressor 20 on and off as it seeks to maintain a desired pressure in the inflation line 40. Thus, additional inflation air provided to the tire or tires 16 after the initial inflation boost provided from the compressed air in the storage tank system, is still provided through the main storage tank 22 which may be described as being at least a portion of the compressed air storage tank system.

Methods of Performing the Rapid Inflation Mode 1

[0080] The methods involved in using Rapid Inflation Mode 1 just described may be described as follows:

- (a) providing on the vehicle 10 the compressed air tank system 22, 24, 26, 28 for storing compressed air, the tank system defining a storage volume;
- (b) providing on the vehicle 10 the air compressor 20;
- (c) storing compressed air from the compressor 20 in the tank system 22, 24, 26, 28 at a storage pressure $PTANK_{0,1}$;
- (d) increasing an inflation pressure of at least one of the tires 16A-16F from an initial tire inflation pressure $PTIRE_{0,1}$ to an intermediate tire inflation pressure $PTIRE_2$ by communicating the tank system 22, 24, 26, 28 with the tire or tires 16A-16F being inflated; and
- (e) further increasing the inflation pressure of the tire or tires being inflated from the intermediate tire inflation pressure $PTIRE_2$ to a final tire inflation pressure $PTIRE_3$ with additional air from the compressor 20 while isolating at least a portion of the storage volume of the tank system, in this case the volume of auxiliary tanks 24, 26 and 28, from communication with the compressor 20.

[0081] The method may further include, after step (e), isolating the tire or tires 16A-16F which were being inflated, from the tank system 22, 24, 26 and 28, then communicating the entire storage volume of all of the tanks 22, 24, 26, 28 of the tank system with the compressor 20 and repressurizing the entire storage volume to the storage pressure $PTANK_{0,1}$.

[0082] In the method, during step (d), the pressure in tank 22 may be monitored with tank pressure sensor 52, and the isolation of the storage volume of auxiliary tanks 24, 26 and 28 by closing valve 38 may be performed after the monitored pressure in the tank system has reached a lowest pressure and begins to rise as shown by the lowest inflection point on the solid line curve 86 in Fig. 6.

[0083] As is apparent in Fig. 6, the lowest pressure that occurs in the tank system is substantially equal to the intermediate tire inflation pressure, which pressures are indicated as $PTANK_2$ and $PTIRE_2$ in the example of Fig. 6.

[0084] In addition to monitoring pressure in the tank system via tank pressure sensor 52, it may also be desired during the inflation process to directly monitor the inflation pressure in one or more of the tires 16 in real time while increasing the inflation pressure. This may be performed, for example, with a respective one of the tire pressure sensors 54 schematically illustrated in Figs. 4 and 5, which as noted above may be TPMS sensors which communicate wirelessly with the controller 72 as schematically illustrated in Fig. 5.

[0085] It is noted that the final tank pressure at time T_4 is represented in Fig. 6 as being equal to the initial tank pressure $PTANK_{0,1}$ which has previously been described as the tank storage pressure. Although the tank storage pressure is shown as being equal at the beginning and the end of the example in Fig. 6, it is not necessary for the tank storage pressure to always be a constant value. It may be changed as desired.

[0086] It is also noted that in the example of Fig. 6, the storage pressure in the tank system as represented by $PTANK_{0,1}$ is higher than the high inflation pressure setting $PTIRE_3$, which in turn is higher than the intermediate tire inflation pressure $PTIRE_2$, which is in turn higher than the low pressure setting $PTIRE_{0,1}$.

[0087] By isolating a substantial portion of the storage volume of the storage tank system by closing valve 38 at time T_2 , the time interval between time T_2 and T_3 to raise the inflation pressure of the tire or tires being inflated to the desired final level $PTIRE_3$ will be shorter than it would be if the valve 38 remained open thus requiring repressurization of the entire storage volume of the tank system to pressure $PTIRE_3$.

Rapid Inflation Mode 2 - Multiple Tire or All Tire Inflation

[0088] First it is noted that the multiple tire or all tire rapid inflation mode described below may be utilized either alone or in combination with the Rapid Inflation Mode 1 feature described above, namely the use of the automated shut off valve 38 to selectively isolate the auxiliary tanks after they have been discharged.

[0089] As previously noted, in the example shown in Fig. 1, the vehicle 10 includes two front tractor tires 16A and 16B, two rear tractor tires 16C and 16D, and two trailer tires 16E and 16F.

[0090] In some situations it will be desirable to inflate multiple ones of the tires simultaneously, or all of the tires simultaneously. For example, in one embodiment it might be desired to inflate only the front tractor tires 16A and 16B.

[0091] In another embodiment it might be desired to inflate only the rear tractor tires 16C and 16D.

[0092] In another embodiment it might be desired to inflate all of the tractor tires 16A-16D.

[0093] In another embodiment it might be desired to inflate the trailer tires 16E and 16F.

[0094] In another embodiment it might be desired to inflate all six tires 16A-16F together.

[0095] As previously noted, one scenario for use of the vehicle 10 with the tire inflation system 18 described herein is to increase the inflation pressure of all of the tires 16A-16F from a low pressure setting in which they are typically used in an agricultural field to a higher pressure setting in which they are typically run along the public roads. Similarly, upon reentering another agricultural field, it may be desirable to simultaneously deflate all of the tires from the higher pressure setting back to the lower pressure setting which is further described below.

[0096] There are many other situations, in which it may be desirable to change the inflation pressure of one or more of the tires. For example if the trailer 14 is carrying a variable load, it may be desired to increase the inflation pressure of the tires 16E and 16F as the load on the trailer 14 increases, and to decrease the inflation pressure in the tires 16E and 16F as the weight decreases.

[0097] Another situation which might create a need for a change in inflation pressure is a change in soil conditions in the field being treated.

[0098] In any of the situations suggested above, and many others, it may be desired to simultaneously inflate two or more of the tires 16A-16F together.

[0099] In such a multiple tire rapid inflation mode, the fill valves 46 associated with two or more of the tires 16 are maintained in their open positions for an initial period until pressure in the air storage tank system and the tires being inflated substantially equalizes, and for a subsequent period during which the compressor 20 provides additional inflation air to the tires being inflated.

[00100] This multiple tire rapid inflation mode may be utilized in conjunction with the use of the shut off valve 38 to isolate a portion of the compressed air storage tank system, or it may be used with a compressed air storage tank system of constant volume.

Methods of Implementation of Multiple Tire or All Tire Rapid Inflation Mode

[00101] The methods of operation utilizing the multiple tire or all tire rapid inflation mode just described above may also be described with regard to the schematic graphical representation of Fig. 6.

[00102] Such a method of rapid inflation of a plurality of tires 16 of the vehicle 10 may comprise steps of:

- (a) providing on the vehicle 10 a compressed air tank system 22, 24, 26, 28;
- (b) providing on the vehicle 10 an air compressor 20;
- (c) providing the plurality of automated fill valves 46A-46F, each fill valve being associated with a respective one of the tires 16A-16F so that each tire can be communicated with the air tank system via a separate one of the fill valves;
- (d) storing compressed air from the compressor 20 in the air tank system 22, 24, 26, 28 at a storage pressure $PTANK_{0,1}$; and
- (e) under control of a multiple tire rapid inflation mode of the controller 72, opening the respective fill valves 46 associated with the tires to be inflated and maintaining the respective fill valves 46 associated with the tires being inflated in their open positions during an initial period from T_1 to T_2 until pressure in the air tank system and the tires being inflated substantially equalizes at $PTANK_2/PTIRE_2$ at time T_2 as seen in Fig. 6, and continuing to maintain those fill valves in their open position during a subsequent period from time T_2 to T_3 during which the compressor 20 provides additional compressed air to the tires being inflated.

[00103] Once the inflation pressure in the plurality of tires being inflated reaches the desired upper setting $PTIRE_3$, then the fill valves 46 associated with the tires being inflated are closed and the compressor 20 continues to repressurize the tank system until the pressure in the tank system reaches again the storage pressure $PTANK_{0,1}$ as schematically illustrated in Fig. 6.

Rapid Deflation Mode

[00104] As previously noted, each of the tires 16A-16F has associated therewith a respective dump valve 58A-58F. When the dump valve 58 associated with a given one of the

tires is opened, it communicates the interior of the tire with an open exhaust zone 60 which may for example be atmospheric pressure.

[00105] It will be appreciated that due to the difference in size of some of the tires 16 as compared to others of the tires, and also because the tires may be at differing inflation pressures, even if all of the dump valves 58 are opened simultaneously to decrease the pressure in their respective tires, each tire may reach the desired lower pressure setting such as $PTIRE_{0,1}$ after a different elapsed time. Thus, in the rapid deflation mode it is preferable to individually monitor the pressure in each tire such as through the tire pressure sensors 54 and then to close each separate one of the dump valves 58A-58F when the inflation pressure in its respective tire drops to a desired low pressure level.

[00106] Thus, the controller 72 may be described as having an all tire rapid deflation mode in which all of the dump valves 58A-58F are initially in their open positions, and each separate dump valve 58A-58F is closed when the inflation pressure in its respective tire drops to a set low pressure such as for example $PTIRE_{0,1}$.

Manual Mode

[00107] The modes of operation described above may be referred to as automatic modes. In these automatic modes the human operator may enter an instruction in controller 72 to switch from the high pressure setting to the low pressure setting or from the low pressure setting to the high pressure setting, and the controller 72 will operate the various valves to accomplish the change.

[00108] Additionally, the controller 72 may include a manual mode in which the human operator may select any one of the fill valves 46 or dump valves 58 to be operated to separately inflate or separately deflate any selected one of the tires 16.

Selection of Components

[00109] To select and properly size the various components of the tire inflation system 18, a typical approach may be as follows.

[00110] First, the problem being addressed can be defined by determining the volume of the tires 16 which are to be inflated, the desired low pressure and high pressure settings of the tires, and the desired minimum inflation time within which it is necessary to inflate the tires from the low pressure setting to the high pressure setting.

[00111] Then, the two component choices which most affect the operation of the tire inflation system 18 and the time intervals depicted in Fig. 6, are the choice of the storage tank volume and the choice of the compressor 20 and its associated output rate.

[00112] The larger the storage volume of the compressed air storage tank system 22, 24, 26 and 28, the higher the intermediate pressure $PTIRE_2$ will be and the less additional pressurization will be necessary from the compressor 20.

[00113] It will be appreciated that generally speaking, the increase in pressure from $PTIRE_{0,1}$ to $PTIRE_2$, which is the time between T_1 and T_2 , will typically be very short on the order of a few seconds. The subsequent time interval from T_2 to T_3 to achieve the final tire inflation pressure $PTIRE_3$ will typically be substantially longer than the interval from T_1 to T_2 . The time from T_2 to T_3 will depend upon the additional pressure which must be provided from the compressor 20 and the output rate of the compressor 20 which determines how quickly it can achieve the desired final pressure within the entire volume of the plurality of tires being inflated.

[00114] There is of course an associated cost of large storage tank systems and of large compressor output capacities, along with related logistical problems of having sufficient room for the storage tank system and related equipment on the tractor 12.

[00115] If an expensive, large capacity compressor 20 is selected, then the need for a large capacity compressed air storage tank system is reduced. On the other hand, if a large capacity compressed air storage tank system is provided, then a smaller and less expensive compressor system may be selected and still provide inflation within acceptable time limits.

[00116] Other factors which will affect the performance of the tire inflation system may include the following.

[00117] In general, all components including piping, fittings, valving and the like should be selected so as to reduce flow restriction as much as possible.

[00118] It is preferable if the fill valves 46 and the dump valves 58 are high capacity quickly opened and closed valves such as solenoid actuated on/off type valves.

[00119] Of particular importance is the selection of the inflation air line 40, 42 and manifold 44 so that there is very low flow restriction between the compressed air storage tank system and the fill valves 46, and the selection of low flow restriction inflation air branch lines 48 between the fill valves 46 and their respective tires 16.

[00120] In general, the components may be selected to provide a tank equalization time from T_1 to T_2 of 10 seconds or less and a total inflation time from T_1 to T_3 of less than 10 minutes, preferably less than 5 minutes, and more preferably less than about one minute.

[00121] The components may also be selected to provide for changes between a field ready low pressure and a road ready high pressure in the following ranges. A field ready pressure in which the tire 10 is pressurized at a relatively low pressure so as to be utilized in a field and to reduce the compaction of the field by the tire, may comprise a pressure in a range of from 4 psi to 16 psi. A road ready pressure, on the other hand, will be at a relatively higher level which may for example involve inflating the tires to a road ready pressure in a range of from 20 psi to 40 psi. The preferred field ready pressures and road ready pressures above may be described as a field ready pressure that is in a range of from 20% to 50% of the road ready pressure, and more preferably wherein the field ready pressure is in a range of from 25% to 40% of the road ready pressure.

Example

[00122] One example of a tire inflation system 18 constructed in accordance with Fig. 3 utilizes four compressed air storage tanks 22, 24, 26 and 28 each having a capacity of 20 gallons. The rotary unions 70C and 70D used with the rear tractor tires 16C and 16D may be of the type which runs air tubing down the axle housing to the rotary union. The outer half of the rotary union is welded to the housing and the inner half of the union is connected to the spinning axle. Such unions are unique because their donut style fits around the axle. Tubing is then run from the spinning side of the rotary union through the wheel to the inlet valve on the wheel. This setup keeps the rotary union protected as it is mounted between the tractor and the wheel, and it is possible because the axle is exposed in that area.

[00123] The rotary unions used with the front tractor tires 16A and 16B and the trailer tires 16E and 16F may be of a different style due to the fact that those axles are not exposed. This type of rotary union is mounted outboard on the wheel. The union is mounted to a bracket on the wheel and is therefore the spinning half, with the stationary half of the union connected to the tubing connection to the tractor.

[00124] In this example, the low tire pressure setting may be selected as 10 psi and the high tire pressure setting may be selected as 20 psi. The combined tire volume in this example is substantially greater than the 80 gallon volume of the tank system. The storage pressure $PTANK_{0,1}$ selected for the compressed air storage tank system may be in the range of 65 to 70 psi.

[00125] With this example, it is possible to rapidly inflate all six tires from a low pressure of 10 psi to a high pressure of 20 psi in about 45 seconds. The time interval from T_1 to T_2 may be approximately 3 seconds and the time interval from T_2 to T_3 may be approximately 42 seconds.

[00126] Thus it is seen that the apparatus and methods of the present invention readily achieve the ends and advantages mentioned as well as those inherent therein. While certain preferred embodiments of the invention have been illustrated and described for purposes of the present disclosure, numerous changes in the arrangement and construction of parts and steps may be made by those skilled in the art, which changes are encompassed with the scope and spirit of the present invention as defined by the appended claims.

CLAIMS

What is claimed is:

1. A tire inflation system for a vehicle supported by a plurality of inflatable tires, the system comprising:

a compressor carried on the vehicle;

an air storage tank carried on the vehicle and connected to the compressor for storing compressed air;

a plurality of automatically operable fill valves, each fill valve being associated with a respective one of the tires so that each tire is communicated with the air storage tank via a separate one of the fill valves to increase inflation pressure in the tire when its respective fill valve is in an open position; and

a controller operably associated with all of the fill valves, the controller having a multiple tire rapid inflation mode in which the fill valves associated with at least two of the tires are maintained in their open positions for an initial period until pressure in the air storage tank and the at least two tires substantially equalizes, and for a subsequent period during which the compressor provides additional inflation air to the at least two tires.

2. The system of claim 1, wherein:

the multiple tire rapid inflation mode is configured such that during the subsequent period the compressor provides the additional inflation air to the at least two tires through the air storage tank.

3. The system of claim 1, wherein:

the multiple tire rapid inflation mode is an all tire rapid inflation mode in which all of the fill valves are maintained in their open positions for the initial period until pressure in the air storage tank and all of the tires substantially equalizes, and for the subsequent period during which the compressor provides additional inflation air to the all of the tires.

4. The system of claim 1, wherein:

each of the fill valves is a non-throttling on-off valve selectively movable between a discrete open position and a discrete closed position.

5. The system of claim 4, wherein:
each of the fill valves is a solenoid operated fill valve.
6. The system of claim 1, wherein:
the controller has a manual mode in which a human operator can separately control each of the fill valves to separately inflate each of the tires.
7. The system of claim 1, further comprising:
a plurality of tire pressure sensors, one of the tire pressure sensors disposed in each of the tires, each tire pressure sensor configured to wirelessly transmit pressure data; and
wherein the controller is configured to receive the pressure data from the tire pressure sensors.
8. The system of claim 1, further comprising:
a plurality of automatically operable dump valves, each dump valve being associated with a respective one of the tires so that each tire is vented via a separate one of the dump valves to decrease inflation pressure in the tire when its respective dump valve is in an open position.
9. The system of claim 8, wherein:
each of the fill valves and each of the dump valves are separate solenoid operated valves, each tire having associated therewith one of the fill valves located in an inflation air line between the air storage tank and the respective tire, and each of the dump valves being communicated with an open exhaust zone and with the inflation air line between the respective fill valve and the tire.
10. The system of claim 8, wherein:
the controller has an all tire rapid deflation mode in which all of the dump valves are initially in their open positions, and each separate dump valve is then closed when the inflation pressure in its respective tire drops to a set low pressure level.

11. The system of claim 1, wherein:
the controller includes an input device configured such that a human operator can enter a low pressure setting and a high pressure setting into the controller; and
the controller is configured in the multiple tire rapid inflation mode to maintain the fill valves associated with the at least two tires in their open positions until inflation pressure in the at least two tires reaches the high pressure setting.

12. The system of claim 11, further comprising:
a tank pressure sensor communicated with the air storage tank; and
wherein the controller is operably associated with the tank pressure sensor to receive signals indicative of air pressure in the air storage tank, and the controller is configured to control inflation pressure in the tires based upon the signals from the tank pressure sensor.

13. The system of claim 1, wherein:
each of the fill valves is incorporated in a three-way valve having the open position, a dump position in which the respective tire is vented to decrease inflation pressure in the tire, and a blocked position in which there is no flow of air to or from the tire through the three-way valve.

14. The system of claim 1, further comprising:
an inflation air main line connected to the air storage tank;
a manifold connected to the inflation air main line, each of the fill valves being connected to the manifold, so that that each fill valve is communicated with the air storage tank through the manifold and the inflation air main line; and
a plurality of separate inflation air branch lines, each fill valve being communicated with its respective tire by one of the separate inflation air branch lines.

15. The system of claim 14, wherein:
the inflation air main line comprises one and only one tubular conduit communicating the air storage tank with the manifold.

16. The system of claim 1, the vehicle including a tractor having at least first and second axles, and a trailer having at least a third axle, and wherein:
the compressor and air storage tank are carried on the tractor; and

at least one of the fill valves is communicated with a tire of the tractor and at least one of the fill valves is communicated with a tire of the trailer.

17. The system of claim 1, wherein:
the air storage tank is a main air storage tank; and
the system further comprises an auxiliary air storage tank carried on the vehicle and connected to the main air storage tank.

18. A method of rapid inflation of a plurality of tires of a vehicle, the method comprising:

- (a) providing on the vehicle a compressed air tank system;
- (b) providing on the vehicle an air compressor;
- (c) providing a plurality of automated fill valves, each fill valve being associated with a respective one of the tires so that each tire can be communicated with the air tank system via a separate one of the fill valves;
- (d) storing compressed air from the compressor in the air tank system at a storage pressure; and
- (e) under control of a multiple tire rapid inflation mode of a controller, opening the fill valves associated with at least two of the tires and maintaining the fill valves associated with the at least two tires in their open positions during an initial period until pressure in the air tank system and the at least two tires substantially equalizes, and during a subsequent period during which the compressor provides additional inflation air to the at least two tires.

19. The method of claim 18, wherein:
during the subsequent period of step (e) the compressor provides the additional inflation air to the at least two tires through at least part of the air tank system.

20. The method of claim 18, wherein:
in step (e) the multiple tire rapid inflation mode is an all tire rapid inflation mode in which all of the fill valves are maintained in their open positions for the initial period until pressure in the air storage tank and all of the tires substantially equalizes, and for the subsequent period during which the compressor provides additional inflation air to the all of the tires.

21. The method of claim 18, wherein:
during step (e) the controller monitors air pressure in the air tank system.
22. The method of claim 18, wherein:
during step (e) the controller monitors air pressure in the tires.
23. The method of claim 18, further comprising:
providing a plurality of automatically operated dump valves, each dump valve being associated with a respective one of the tires; and
selectively venting any one of the tires via a separate one of the dump valves to decrease inflation pressure in the selected tire.
24. The method of claim 18, further comprising:
providing a plurality of automatically operated dump valves, each dump valve being associated with a respective one of the tires; and
under control of an all tire rapid deflation mode of the controller, simultaneously venting all of the tires by opening all of the dump valves to decrease inflation pressure in the tires.
25. The method of claim 18, wherein:
in step (c), each of the fill valves is a three-way valve having an open position in which the respective tire is communicated with the air tank system, a dump position in which the respective tire is vented to decrease inflation pressure in the tire, and a blocked position in which there is no flow of air to or from the tire through the three-way valve.
26. The method of claim 18, wherein:
inputting a low pressure setting and a high pressure setting into the controller; and
in step (e), during the subsequent period maintaining the fill valves associated with the at least two tires in their open positions until inflation pressure in the at least two tires reaches the high pressure setting.
27. The method of claim 18, further comprising:
providing an inflation air main line connecting the compressed air tank system to a manifold, each of the fill valves being connected to the manifold; and

providing a plurality of separate inflation air branch lines, each fill valve being communicated with its respective tire by one of the separate inflation air branch lines, so that during step (e) inflation air flows to each of the at least two tires through the inflation air main line, the manifold and a respective one of the inflation air branch lines.

+

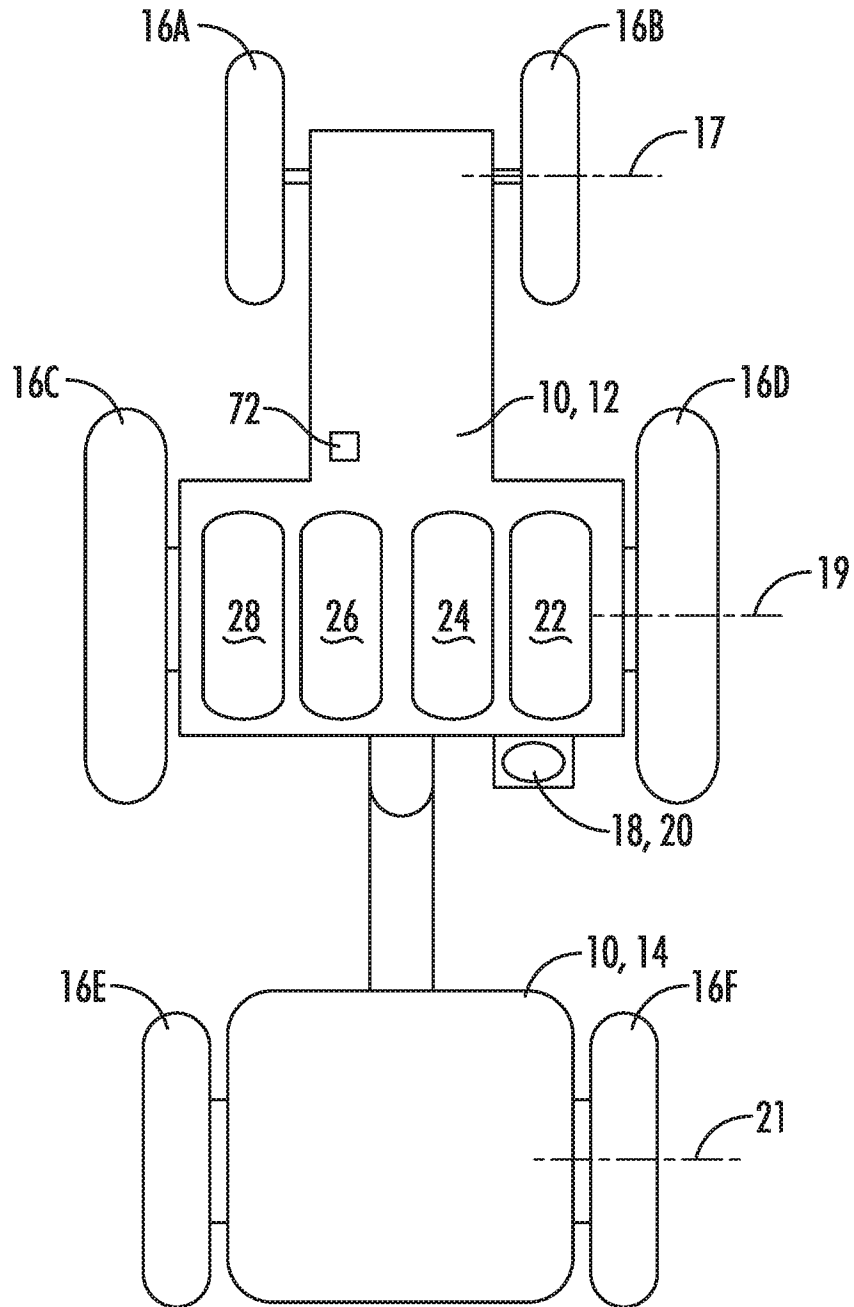

FIG. 1

+

+

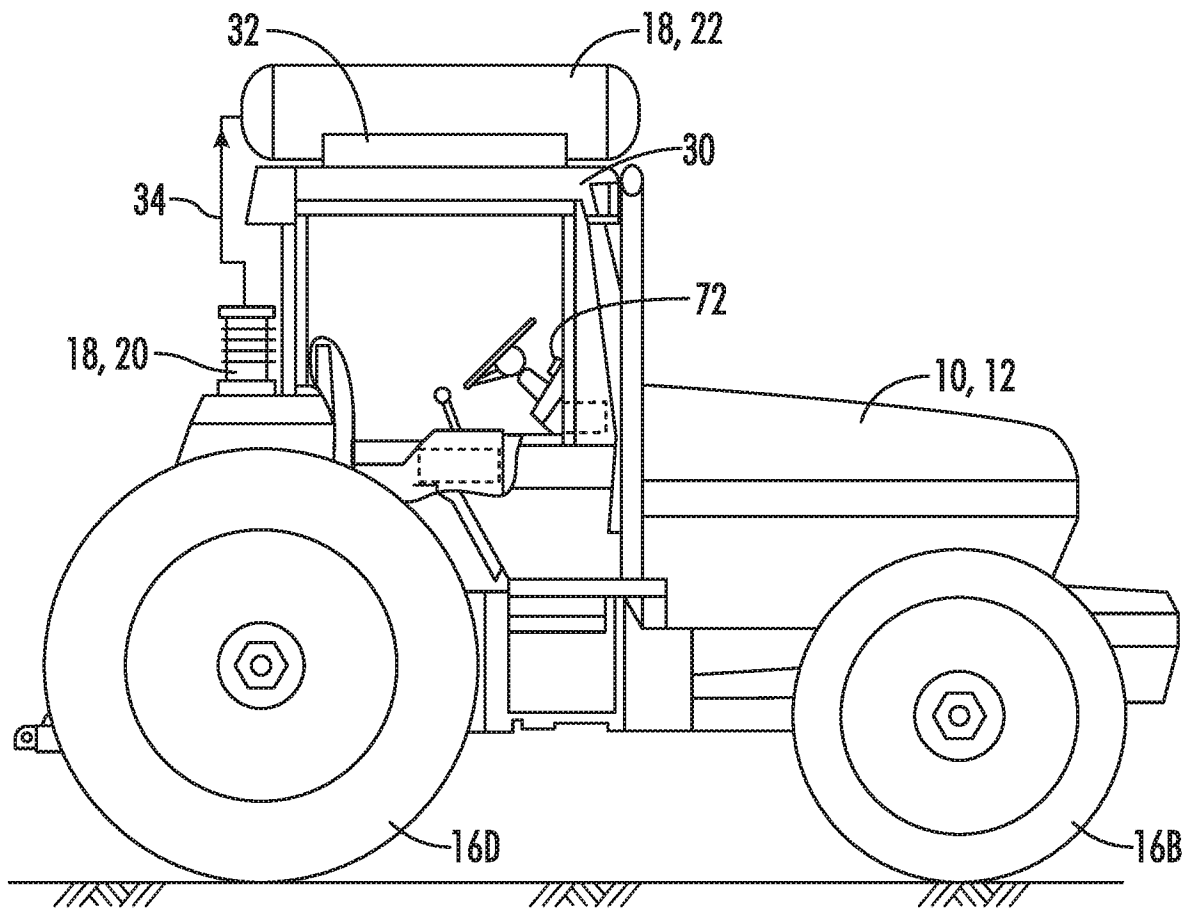

FIG. 2

+

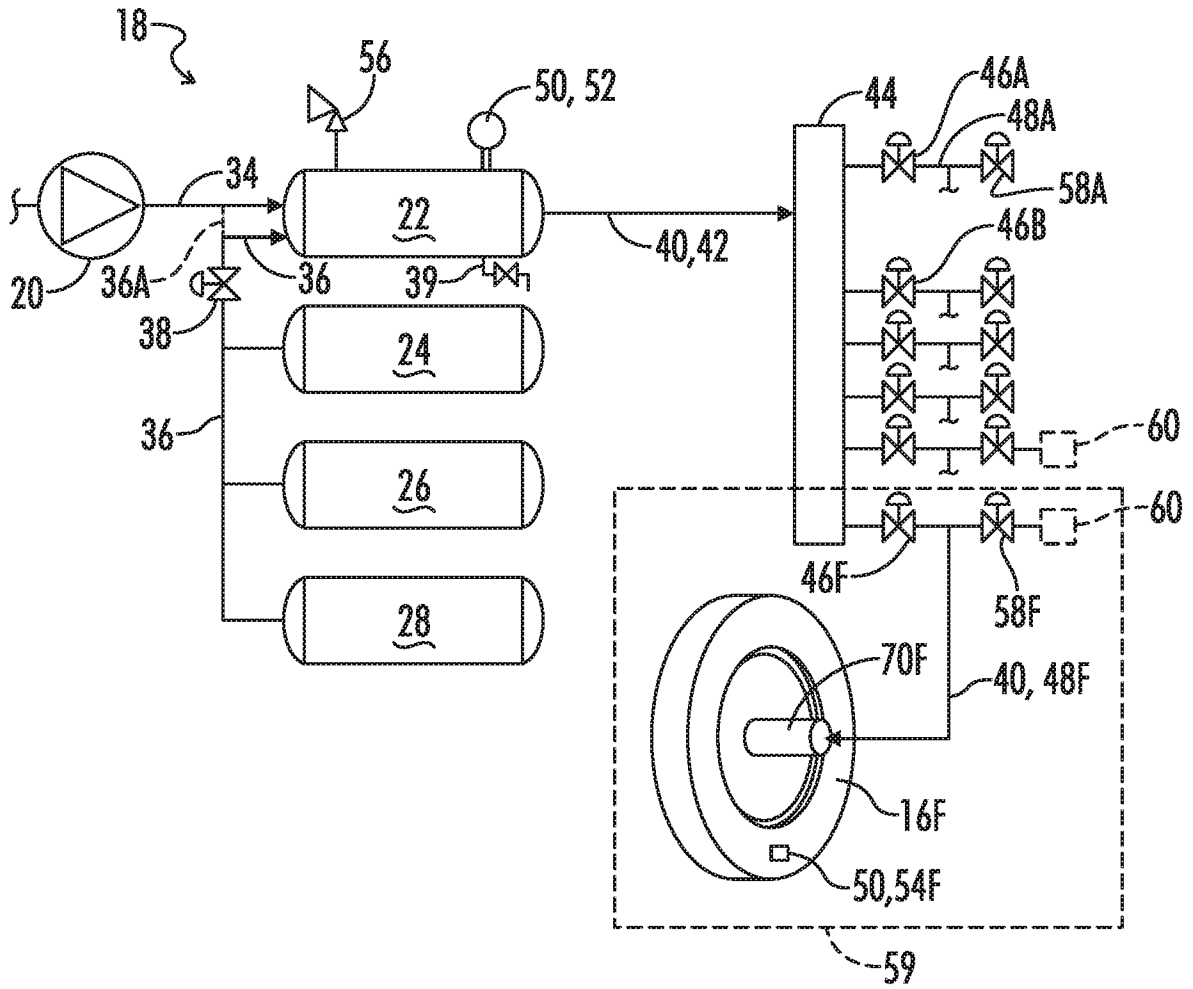

FIG. 3

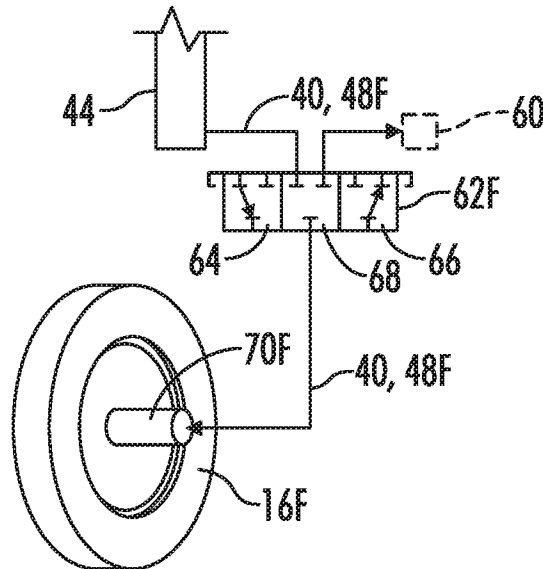

FIG. 4

4/5

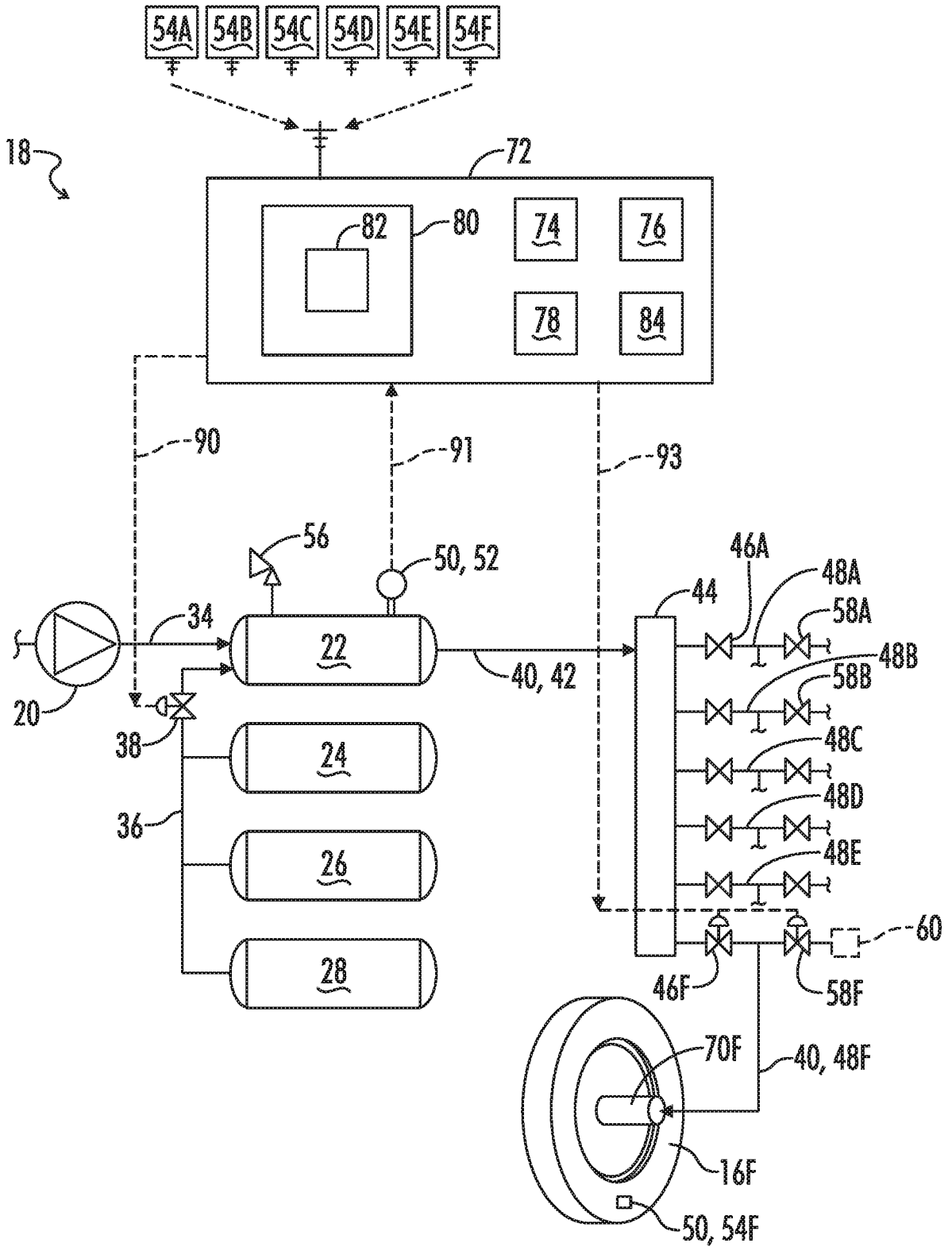

FIG. 5

+

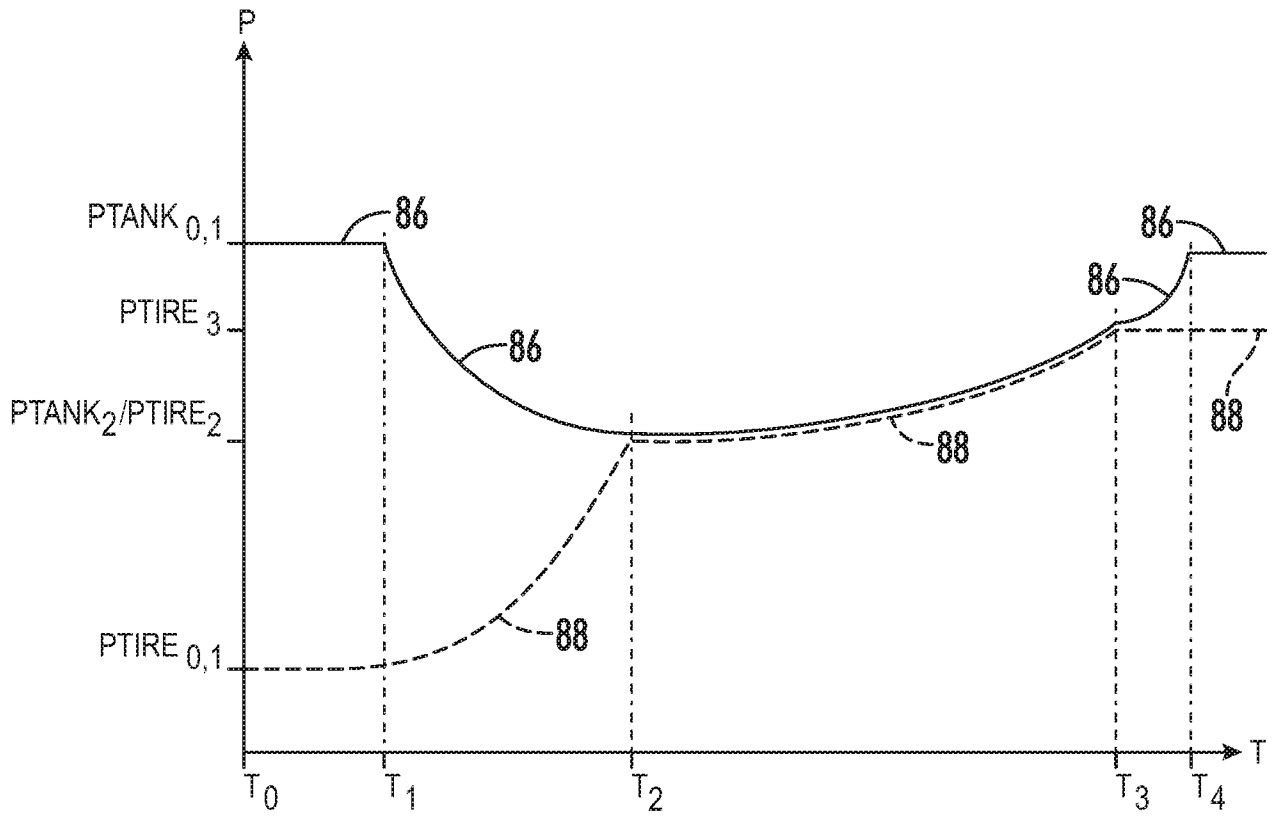

FIG. 6

+

A. CLASSIFICATION OF SUBJECT MATTER**B60S 5/04(2006.01)i**

According to International Patent Classification (IPC) or to both national classification and IPC

B. FIELDS SEARCHEDMinimum documentation searched (classification system followed by classification symbols)
B60S 5/04; B60C 23/00; B44C 3/06; G06F 11/10; B60C 23/10Documentation searched other than minimum documentation to the extent that such documents are included in the fields searched
Korean utility models and applications for utility models
Japanese utility models and applications for utility modelsElectronic data base consulted during the international search (name of data base and, where practicable, search terms used)
eKOMPASS(KIPO internal) & keywords: distribution, rapid inflation, air, tire, pressure, compressor, storage tank, and controller**C. DOCUMENTS CONSIDERED TO BE RELEVANT**

Category*	Citation of document, with indication, where appropriate, of the relevant passages	Relevant to claim No.
X	US 5587698 A (GENNA, ROBERT A.) 24 December 1996 See column 10, lines 28-60, column 14, lines 4-30, column 18, lines 23-64, claim 1, and figures 1-3, 14.	1-11, 13-20, 22-27
Y		12, 21
Y	WO 2008-142679 A2 (ELBER LLC et al.) 27 November 2008 See page 13, lines 15-26 and figure 4.	12, 21
A	US 5553647 A (JAKSIC, MIROSLAV) 10 September 1996 See abstract, column 2, line 15 - column 3, line 32, and figure 1.	1-27
A	US 8955566 B2 (LOEWE, RICHARD) 17 February 2015 See abstract, column 6, line 10 - column 8, line 51, and figures 2-7.	1-27
A	US 2012-0218095 A1 (ZHOU, JOE HUAYUE) 30 August 2012 See paragraphs [0045]-[0047] and figure 10.	1-27

 Further documents are listed in the continuation of Box C. See patent family annex.

* Special categories of cited documents:

"A" document defining the general state of the art which is not considered to be of particular relevance

"E" earlier application or patent but published on or after the international filing date

"L" document which may throw doubts on priority claim(s) or which is cited to establish the publication date of another citation or other special reason (as specified)

"O" document referring to an oral disclosure, use, exhibition or other means

"P" document published prior to the international filing date but later than the priority date claimed

"T" later document published after the international filing date or priority date and not in conflict with the application but cited to understand the principle or theory underlying the invention

"X" document of particular relevance; the claimed invention cannot be considered novel or cannot be considered to involve an inventive step when the document is taken alone

"Y" document of particular relevance; the claimed invention cannot be considered to involve an inventive step when the document is combined with one or more other such documents, such combination being obvious to a person skilled in the art

"&" document member of the same patent family

Date of the actual completion of the international search

20 March 2017 (20.03.2017)

Date of mailing of the international search report

20 March 2017 (20.03.2017)

Name and mailing address of the ISA/KR

International Application Division
Korean Intellectual Property Office
189 Cheongsa-ro, Seo-gu, Daejeon, 35208, Republic of Korea

Facsimile No. +82-42-481-8578

Authorized officer

LEE, Chang Ho

Telephone No. +82-42-481-8288

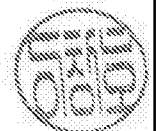

INTERNATIONAL SEARCH REPORT

Information on patent family members

International application No.

PCT/US2016/065117

Patent document cited in search report	Publication date	Patent family member(s)	Publication date
US 5587698 A	24/12/1996	None	
WO 2008-142679 A2	27/11/2008	IL 183313 A WO 2008-142679 A3	20/09/2007 25/02/2010
US 5553647 A	10/09/1996	WO 96-18514 A1	20/06/1996
US 8955566 B2	17/02/2015	CA 2586319 A1 CA 2586319 C CN 101111400 A CN 101111400 B EP 1817180 A2 EP 1817180 B1 JP 2008-519735 A US 2006-0102268 A1 US 2007-0107822 A1 US 2007-0151648 A1 US 2008-0135151 A1 US 2010-0288411 A1 US 2015-0114537 A1 US 7237590 B2 US 7357164 B2 US 7607465 B2 US 7784513 B2 WO 2006-053318 A2 WO 2006-053318 A3 WO 2008-106050 A1	18/05/2006 13/01/2015 23/01/2008 12/01/2011 15/08/2007 17/08/2011 12/06/2008 18/05/2006 17/05/2007 05/07/2007 12/06/2008 18/11/2010 30/04/2015 03/07/2007 15/04/2008 27/10/2009 31/08/2010 18/05/2006 01/03/2007 04/09/2008
US 2012-0218095 A1	30/08/2012	US 8564429 B2	22/10/2013