

(12) STANDARD PATENT
(19) AUSTRALIAN PATENT OFFICE

(11) Application No. **AU 2009206098 B2**

(54) Title
Interspinous spacer

(51) International Patent Classification(s)
A61F 2/44 (2006.01) **A61F 2/30** (2006.01)

(21) Application No: **2009206098** (22) Date of Filing: **2009.01.15**

(87) WIPO No: **WO09/091922**

(30) Priority Data

(31) Number	(32) Date	(33) Country
61/011,199	2008.01.15	US

(43) Publication Date: **2009.07.23**

(44) Accepted Journal Date: **2014.10.30**

(71) Applicant(s)
VertiFlex, Inc.

(72) Inventor(s)
Tebbe, Shawn;Altarac, Moti;Kim, Daniel H.

(74) Agent / Attorney
Shelston IP, L 21 60 Margaret St, Sydney, NSW, 2000

(56) Related Art
US 2007/0276370
US 5876404
US 2007/0161991
US 2007/0191837
US 2007/0213829
US 2007/0270824
FR 2888744
FR 2884136
US 2007/0093823
SU 988281
FR 2722980
FR 2681525



(51) International Patent Classification:
A61F 2/44 (2006.01) A61F 2/30 (2006.01)

(21) International Application Number:
PCT/US2009/031150

(22) International Filing Date:
15 January 2009 (15.01.2009)

(25) Filing Language: English

(26) Publication Language: English

(30) Priority Data:
61/011,199 15 January 2008 (15.01.2008) US

(63) Related by continuation (CON) or continuation-in-part (CIP) to earlier application:
US 61/011,199 (CIP)
Filed on 15 January 2008 (15.01.2008)

(71) Applicant (for all designated States except US): **VERTI-FLEX, INC.** [US/US]; 1351 Calle Avanzado, San Clemente, CA 92673 (US).

(72) Inventors; and

(75) Inventors/Applicants (for US only): **ALTARAC, Moti** [IL/US]; 67 Coriander, Irvine, CA 92603 (US). **TEBBE, Shawn** [US/US]; 2022 Estero Street, Oceanside, CA 92054 (US). **KIM, Daniel, H.** [US/US]; 227 East Cowan, Houston, TX 77007 (US).

(74) Agent: **LUKAS, Rimas**; 1351 Calle Avanzado, San Clemente, CA 92673 (US).

(81) Designated States (unless otherwise indicated, for every kind of national protection available): AE, AG, AL, AM, AO, AT, AU, AZ, BA, BB, BG, BH, BR, BW, BY, BZ, CA, CH, CN, CO, CR, CU, CZ, DE, DK, DM, DO, DZ, EC, EE, EG, ES, FI, GB, GD, GE, GH, GM, GT, HN, HR, HU, ID, IL, IN, IS, JP, KE, KG, KM, KN, KP, KR, KZ, LA, LC, LK, LR, LS, LT, LU, LY, MA, MD, ME, MG, MK, MN, MW, MX, MY, MZ, NA, NG, NI, NO, NZ, PG, PH, PL, PT, RO, RS, RU, SC, SD, SE, SG, SK, SL, SM, ST, SV, SY, TJ, TM, TN, TR, TT, TZ, UA, UG, US, UZ, VC, VN, ZA, ZM, ZW.

[Continued on next page]

(54) Title: INTERSPINOUS SPACER

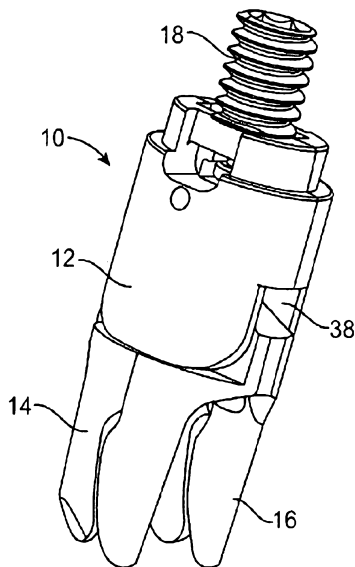

FIG. 1a

(57) Abstract: An implantable spacer for placement between adjacent spinous processes in a spinal motion segment is provided. The spacer includes a body defining a longitudinal passageway. A first arm and a second arm are connected to the body. Each arm has a pair of extensions and a saddle defining a receiving portion configured for seating a spinous process of a scoliotic spine or a spine with misaligned spinous processes. Each arm has a proximal camming surface and is capable of rotation with respect to the body. An actuator assembly is disposed inside the passageway and connected to the body. When advanced, a threaded shaft of the actuator assembly contacts the camming surfaces of arms to rotate them from an undeployed to a deployed configuration. In the deployed configuration, the distracted adjacent spinous processes are seated in the superior and inferior arms of the spacer. Variations adapted for scoliotic curves are provided.



(84) Designated States (unless otherwise indicated, for every kind of regional protection available): ARIPO (BW, GH, GM, KE, LS, MW, MZ, NA, SD, SL, SZ, TZ, UG, ZM, ZW), Eurasian (AM, AZ, BY, KG, KZ, MD, RU, TJ, TM), European (AT, BE, BG, CH, CY, CZ, DE, DK, EE, ES, FI, FR, GB, GR, HR, HU, IE, IS, IT, LT, LU, LV, MC, MK, MT, NL, NO, PL, PT, RO, SE, SI, SK, TR), OAPI (BF, BJ, CF, CG, CI, CM, GA, GN, GQ, GW, ML, MR, NE, SN, TD, TG).

Published:

- with international search report (Art. 21(3))
- before the expiration of the time limit for amending the claims and to be republished in the event of receipt of amendments (Rule 48.2(h))

(88) Date of publication of the international search report:

29 October 2009

INTERSPINOUS SPACER

CROSS-REFERENCE TO RELATED APPLICATIONS

[0001] This application claims priority to and the benefit of and is a continuation-in-part of U.S. Provisional Patent Application Serial No. 61/011,199 entitled "Interspinous spacer" filed on January 15, 2008 which is incorporated herein by reference in its entirety. This application also claims priority to and is a continuation-in-part of U.S. Patent Application Serial No. 12/338,793 entitled "Spacer insertion instrument" filed on December 18, 2008 which is a non-provisional of U.S. Provisional Patent Application Serial No. 61/008,418 entitled "Spacer insertion instrument" filed on December 19, 2007 which is incorporated herein by reference in its entirety. This application also claims priority to and is a continuation-in-part of U.S. Patent Application Serial No. 12/205,511 entitled "Interspinous spacer" filed on September 5, 2008 which is a non-provisional of U.S. Provisional Patent Application Serial No. 60/967,805 entitled "Interspinous spacer" filed on September 7, 2007 and a continuation-in-part of U.S. Patent Application Serial No. 12/220,427 entitled "Interspinous spacer" filed on July 24, 2008 which is a non-provisional of U.S. Provisional Patent Application Serial No. 60/961,741 entitled "Interspinous spacer" filed on July 24, 2007 and is a continuation-in-part of U.S. Patent Application Serial No. 12/217,662 entitled "Interspinous spacer" filed on July 8, 2008 which is a non-provisional of U.S. Provisional Patent Application No. 60/958,876 entitled "Interspinous spacer" filed on July 9, 2007 and a continuation-in-part of U.S. Patent Application Serial No. 12/148,104 entitled "Interspinous spacer" filed on April 16, 2008 which is a non-provisional of U.S. Provisional Patent Application Serial No. 60/923,971 entitled "Interspinous spacer" filed on April 17, 2007 and U.S. Provisional Patent Application Serial No. 60/923,841 entitled "Spacer insertion instrument" filed on April 16, 2007, all of which are hereby incorporated by reference in their entireties. This application is also a continuation-in-part of U.S. Patent Application Serial No. 11/593,995 entitled "Systems and methods for posterior dynamic stabilization of the spine" filed on November 7, 2006 and a continuation-in-part of U.S. Patent Application Serial No. 11/582,874 entitled "Minimally invasive tooling for delivery of interspinous spacer" filed on October 18, 2006 and a continuation-in-part of U.S. Patent Application Serial No. 11/314,712 entitled "Systems and methods for posterior dynamic stabilization of the spine" filed on December 20, 2005 and a continuation-in-part of U.S. Patent Application Serial No. 11/190,496 entitled "Systems and methods for posterior dynamic stabilization of the spine" filed on July 26, 2005 and a continuation-in-part of U.S. Patent Application Serial No. 11/079,006 entitled "Systems and methods for posterior dynamic

[0002] stabilization of the spine" filed on March 10, 2005 which is a continuation-in-part of U.S. Patent Application Serial No. 11/052,002 entitled "Systems and methods for posterior dynamic stabilization of the spine" filed on February 4, 2005 which is a continuation-in-part of U.S. Patent Application Serial No. 11/006,502 entitled "Systems and methods for posterior dynamic stabilization of the spine" filed on December 6, 2004 which is a continuation-in-part of U.S. Patent Application Serial No. 10/970,843 entitled "Systems and methods for posterior dynamic stabilization of the spine" filed on October 20, 2004, all of which are hereby incorporated by reference in their entireties.

[0003] Any discussion of the prior art throughout the specification should in no way be considered as an admission that such prior art is widely known or forms part of common general knowledge in the field.

BACKGROUND

[0004] With spinal stenosis, the spinal canal narrows and pinches the spinal cord and nerves, causing pain in the back and legs. Typically, with age, a person's ligaments may thicken, intervertebral discs may deteriorate and facet joints may break down — all contributing to the condition of the spine characterized by a narrowing of the spinal canal. Injury, heredity, arthritis, changes in blood flow and other causes may also contribute to spinal stenosis.

[0005] Doctors have been at the forefront with various treatments of the spine including medications, surgical techniques and implantable devices that alleviate and substantially reduce debilitating pain associated with the back. In one surgical technique, a spacer is implanted between adjacent spinous processes of a patient's spine. The implanted spacer opens the foramen and spinal canal, maintains the desired distance between vertebral body segments, and as a result, avoids impingement of nerves and relieves pain. For suitable candidates, an implantable interspinous spacer may provide significant benefits in terms of pain relief. However, there is a need for an implantable interspinous spacer for patients with adjacent spinous processes that are not aligned such as in patients suffering with scoliosis.

[0006] Scoliosis is the lateral or sideways curvature caused by congenital, neuromuscular, idiopathic, syndromic or postural conditions. An example of a scoliotic spine is shown in FIG. 12.

[0007] Any surgery is an ordeal. However, the type of device and how it is implanted has an impact. For example, one consideration when performing surgery to implant an interspinous spacer is the size of the incision that is required to allow introduction of the device. Small incisions and minimally invasive techniques are quick and generally preferred as they affect less tissue and result in speedier recovery times. As such, there is a need for interspinous spacers that work well with surgical techniques that are minimally invasive for a patient with misaligned spinous processes such as patients with scoliosis. The present invention sets forth such a spacer.

SUMMARY

[0008] In a first aspect, the invention provides an implant for placement between adjacent spinous processes in a spinal motion segment, the implant comprising:

- a body defining a longitudinal axis;

- a first arm connected to the body and configured to laterally stabilize the body with respect to a first spinous process when in a deployed configuration, wherein the first arm includes a pair of first extensions configured to receive the first spinous process between the first extensions; and

- a second arm connected to the body and configured to laterally stabilize the body with respect to a second spinous process when in a deployed configuration;

- a first bridge connected between the first extensions to define a first spinous process receiving portion, wherein the first pair of extensions are substantially parallel to a sagittal plane of the implant and the first bridge is angled with respect to the sagittal plane of the implant; and

- wherein the first and second arms are configured for placement between adjacent spinous processes in which at least one of the adjacent spinous processes has a projection in a coronal plane that is angled with respect to the sagittal plane.

[0009] Unless the context clearly requires otherwise, throughout the description and the claims, the words “comprise”, “comprising”, and the like are to be construed in an inclusive sense as opposed to an exclusive or exhaustive sense; that is to say, in the sense of “including, but not limited to”.

[0010] In a second aspect, the invention provides an implant for placement between adjacent spinous processes in a spinal motion segment, the implant comprising:

- a body defining a longitudinal axis;

a first arm connected to the body and configured to laterally stabilize the body with respect to a first spinous process when in a deployed configuration, wherein the first arm includes a pair of first extensions configured to receive the first spinous process between the first extensions; and

a second arm connected to the body and configured to laterally stabilize the body with respect to a second spinous process when in a deployed configuration, wherein the second arm includes a pair of second extensions configured to receive the second spinous process between the second extensions;

a first bridge connected between the first pair of extensions to define a first spinous process receiving portion;

a second bridge connected between the second pair of extensions to define a second spinous process receiving portion; and

wherein the first and second arms are configured for placement between the spinous processes in which at least one of the adjacent spinous processes has a projection in a coronal plane that is angled with respect to a sagittal plane of the implant, wherein the pair of first extensions and the pair of second extensions are substantially parallel to the sagittal plane of the implant and the first and second bridges are angled with respect to the sagittal plane of the implant.

[0011] In a third aspect, the invention provides an implant for placement between adjacent spinous processes in a spinal motion segment, the implant comprising:

a body defining a longitudinal axis;

a first arm connected to the body and configured to laterally stabilize the body with respect to a first spinous process when in a deployed configuration, wherein the first arm includes a pair of first extensions at a first fixed spaced apart relationship relative to one another and configured to receive the first spinous process between the first extensions; and

a second arm connected to the body and configured to laterally stabilize the body with respect to a second spinous process when in a deployed configuration, wherein the second arm includes a pair of second extensions at a second fixed spaced apart relationship relative to one another and configured to receive the second spinous process between the second extensions;

wherein the first and second arms are configured for placement between adjacent spinous processes in which at least one of the adjacent spinous processes has a projection in a coronal plane that is angled with respect to a sagittal plane of the implant, wherein each of the first extensions is permanently angled with respect to the sagittal plane of the implant and

each of the second extensions is permanently angled with respect to the sagittal plane of the implant.

[0012] In a fourth aspect, the invention provides an implant for placement between adjacent spinous processes in a spinal motion segment, the implant comprising:

a body defining a longitudinal axis;

a first arm connected to the body and configured to laterally stabilize the body with respect to a first spinous process when in a deployed configuration, wherein the first arm includes a pair of first extensions configured to receive the first spinous process between the first extensions; and

a second arm connected to the body and configured to laterally stabilize the body with respect to a second spinous process when in a deployed configuration, wherein the second arm includes a pair of second extensions configured to receive the second spinous process between the second extensions;

a first bridge connected between the first pair of extensions to define a first spinous process receiving portion;

a second bridge connected between the second pair of extensions to define a second spinous process receiving portion; and

wherein the first and second arms are configured for placement between adjacent spinous processes and which at least one of the adjacent spinous processes has a projection in a coronal plane that is angled with respect to a sagittal plane of the implant, wherein the pair of first extensions is angled with respect to the sagittal plane of the implant and the pair of second extensions is angled with respect to the sagittal plane of the implant and the first and second bridges are perpendicular to their respective extensions to which they are connected.

[0013] The specification also describes an implant for placement between adjacent spinous processes in a spinal motion segment comprising:

a body defining a longitudinal axis;

a first arm connected to the body; the first arm having a first pair of extensions defining a spinous process receiving portion for seating a superior spinous process therein; and

a second arm connected to the body; the second arm having a second pair of extensions defining a spinous process receiving portion for seating an inferior spinous process therein;

wherein the distance between the first pair of extensions is greater than the distance between the second pair of extensions, the first and second arms are configured for placement

between adjacent spinous processes in which at least one of the adjacent spinous processes has a projection in a coronal plane that is angled with respect to the sagittal plane, and the first pair of extensions are substantially parallel and the second pair of extensions are substantially parallel.

[0014] The specification further describes an implant for placement between adjacent spinous processes in a spinal motion segment comprising:

- a body defining a longitudinal axis;

- a first arm connected to the body; the first arm having a first pair of extensions defining a spinous process receiving portion for seating a superior spinous process therein;

- a second arm connected to the body; the second arm having a second pair of extensions defining a spinous process receiving portion for seating an inferior spinous process therein;

- a first bridge between the first pair of extensions;

- a second bridge between the second pair of extensions; and

wherein one extension of the first pair and one extension of the second pair that are adjacent to each other on the same side of the implant are both shorter than the other of the extensions, and the first and second arms are configured for placement between adjacent spinous processes in which at least one of the adjacent spinous processes has a projection in a coronal plane that is angled with respect to the sagittal plane.

[0015] The specification also describes an implant for placement between adjacent spinous processes in a spinal motion segment comprising:

- a body defining a longitudinal axis;

- a first arm connected to the body; the first arm having a first pair of extensions defining a spinous process receiving portion for seating a superior spinous process therein; and

- a second arm connected to the body; the second arm having a second pair of extensions defining a spinous process receiving portion for seating an inferior spinous process therein;

wherein one extension of the first pair and one extension of the second pair that are adjacent to each other on the same side of the implant are both shorter than the other of the extensions, wherein the first and second arms are angled with respect to each other such that the shorter extensions are angled towards each other, and the first and second arms are configured for placement between adjacent spinous processes in which at least one of the

adjacent spinous processes has a projection in a coronal plane that is angled with respect to the sagittal plane.

[0016] In a fifth aspect, the invention provides an implant for placement between a first spinous process and a second spinous process in a spinal motion segment, the implant comprising:

- a body defining a sagittal plane;

- a first arm rotatably coupled to the body and configured to rotate relative to the body about a first axis of rotation generally perpendicular to the sagittal plane such that the first arm moves from an undeployed configuration to a deployed configuration, the first arm is configured to laterally stabilize the body with respect to the first spinous process when in the deployed configuration, the first arm comprising a first pair of generally parallel extensions configured to receive the first spinous process when the first arm moves from the undeployed configuration to the deployed configuration; and

- a second arm rotatably coupled to the body and configured to rotate relative to the body about a second axis of rotation generally perpendicular to the sagittal plane such that the second arm moves from an undeployed configuration to a deployed configuration, the second arm is configured to laterally stabilize the body with respect to the second spinous process when in the deployed configuration;

- wherein the first and second arms are configured for placement between the first and second spinous processes in which the first pair of extensions are oriented at a non-parallel angle with respect to the sagittal plane in the deployed configuration.

[0017] In a sixth aspect, the invention provides an implant for placement between adjacent vertebrae in a spinal motion segment, the implant comprising:

- a body defining a sagittal plane;

- a first arm connected to the body, the first arm having a first pair of substantially parallel extensions defining a first spinous process receiving portion for seating a superior spinous process therein when the first arm rotates relative to the body about a first axis that is substantially perpendicular to the sagittal plane; and

- a second arm connected to the body, the second arm having a second pair of substantially parallel extensions defining a second spinous process receiving portion for seating an inferior spinous process therein when the second arm rotates relative to the body about a second axis that is substantially perpendicular to the sagittal plane;

- wherein a distance between the first pair of extensions is greater than a distance between the second pair of extensions; and

wherein when the first and second spinous process receiving portions seat the corresponding superior and inferior spinous process, each of the first and second pairs of extensions is oriented at an acute angle with respect to the sagittal plane.

[0018] In a seventh aspect, the invention provides an implant for placement between adjacent spinous processes in a spinal motion segment, the implant comprising:

a body defining a longitudinal axis;

a first arm connected to the body, the first arm having a first pair of extensions defining a spinous process receiving portion, wherein the first pair of extensions move superiorly and posteriorly as the first arm rotates relative to the body to seat a superior spinous process in the spinous process receiving portion when the longitudinal axis extends in an anterior-posterior direction; and

a second arm connected to the body, the second arm having a second pair of extensions defining a spinous process receiving portion, wherein the second pair of extensions move inferiorly and posteriorly as the second arm rotates relative to the body to seat an inferior spinous process in the spinous process receiving portion defined by the second pair of extensions;

wherein one extension of the first pair and one extension of the second pair that are adjacent to each other are both shorter than the other of the extensions; and

wherein the first and second arms are movable from an undeployed configuration in which the first and second arms are generally aligned with the longitudinal axis to a deployed configuration in which the first and second arms extend laterally away from the body at an angle generally perpendicular to the longitudinal axis.

[0019] According to one preferred aspect of the invention, an implant configured for placement between adjacent spinous processes in a spinal motion segment with a scoliotic curve and configured to laterally stabilize the spacer with respect to said adjacent spinous processes is provided.

[0020] An implant for placement between adjacent spinous processes in a spinal motion segment is provided. The implant preferably includes a body defining a longitudinal passageway through at least a portion of the body. A first arm connected to the body and capable of rotation with respect to the body. The first arm has a first pair of extensions and a first bridge defining a spinous process receiving portion for seating a first spinous process therein. The first arm has a first proximal camming surface. The implant further includes a second arm connected to the body and capable of rotation with respect to the body. The

second arm has a second pair of extensions and a second bridge defining a spinous process receiving portion for seating a second spinous process therein. The second arm has a second proximal camming surface. The implant further includes an actuator connected to the body. The actuator is configured such that the actuator is disposed inside the body and configured to move relative to the body and contact the camming surfaces of the arms to rotate them from a first configuration in which the arms are substantially parallel to the longitudinal axis of the body to a second configuration in which the first arm seats the first spinous process and the second arm seats the second spinous process. At least one of the first arm and second arm is configured to seat the spinous processes of a spinal motion segment with a scoliotic curve.

[0021] An implant for placement between adjacent spinous processes in a spinal motion segment is provided. The implant preferably includes a body defining a longitudinal axis. A first arm is connected to the body and has a first pair of extensions defining a spinous process receiving portion for seating a superior spinous process therein. The implant includes a second arm connected to the body. The second arm has a second pair of extensions defining a spinous process receiving portion for seating an inferior spinous process therein. One extension of the first pair and one extension of the second pair that are adjacent to each other on the same side of the spacer are both shorter than the other of the extensions.

[0022] An implant for placement between adjacent spinous processes in a spinal motion segment is provided. The implant preferably includes a body defining a longitudinal axis. A first arm is connected to the body having a first pair of extensions defining a spinous process receiving portion for seating a superior spinous process therein. A second arm is connected to the body. The second arm has a second pair of extensions defining a spinous process receiving portion for seating an inferior spinous process therein. The distance between the first pair of extensions is greater than the distance between the second pair of extensions to accommodate a generally wider lower or caudal end of a superior spinous process relative to a generally narrower upper or cephalad end of an inferior spinous process.

[0023] An implant for placement between adjacent spinous processes in a spinal motion segment is provided. The implant preferably includes a body defining a longitudinal axis. A first arm is connected to the body and configured to laterally stabilize the body with respect to a first spinous process when in a deployed configuration. A second arm is connected to the body and configured to laterally stabilize the body with respect to a second spinous process when in a deployed configuration. The first and second arms are configured for placement between

adjacent spinous processes in which at least one of the adjacent spinous processes has a projection in a coronal plane that is angled with respect to the sagittal plane.

BRIEF DESCRIPTION OF THE DRAWINGS

[0024] A preferred embodiment of the invention will now be described, by way of example only, with reference to the accompanying drawings in which:

[0025] FIG. 1a is a perspective view of a spacer according to the present invention.

[0026] FIG. 1b is a side view of a spacer according to the present invention.

[0027] FIG. 1c is a top view of a spacer according to the present invention.

[0028] FIG. 1d is a cross-sectional view of a spacer taken along line A-A of FIG. 1c according to the present invention.

[0029] FIG. 1e is an end view of a spacer according to the present invention.

[0030] FIG. 1f is an exploded view of a spacer according to the present invention.

[0031] FIG. 2a is a perspective view of a half of a body of a spacer according to the present invention.

[0032] FIG. 2b is a side view of half of a body of a spacer according to the present invention.

[0033] FIG. 2c is a perspective view of a half of a body of a spacer according to the present invention.

[0034] FIG. 2d is a side view of half of a body of a spacer according to the present invention.

[0035] FIG. 3a is a perspective view of a superior wing of a spacer according to the present invention.

[0036] FIG. 3b is a top view of a superior wing of a spacer according to the present invention.

[0037] FIG. 3c is a side view of a superior wing of a spacer according to the present invention.

[0038] FIG. 3d is a perspective view of an inferior wing of a spacer according to the present invention.

[0039] FIG. 3e is a bottom view of an inferior wing of a spacer according to the present invention.

[0040] FIG. 3f is a side view of an inferior wing of a spacer according to the present invention.

[0041] FIG. 4a is a side view of a spacer according to the present invention.

[0042] FIG. 4b is a side view of a spacer with wings partially deployed according to the present invention.

[0043] FIG. 4c is a side view of a spacer with wings in a deployed configuration according to the present invention.

[0044] FIG. 4d is a side view of a spacer with wings in a deployed and extended configuration according to the present invention.

[0045] FIG. 5a is a cross-sectional view of a spacer with wings in a partially deployed configuration according to the present invention.

[0046] FIG. 5b is a cross-sectional view of a spacer with wings in a deployed configuration according to the present invention.

[0047] FIG. 5c is a cross-sectional view of a spacer with wings in a deployed and extended configuration according to the present invention.

[0048] FIG. 6a is a semi-transparent view of a spacer with wings partially deployed according to the present invention.

[0049] FIG. 6b is a semi-transparent view of a spacer with wings in a deployed configuration according to the present invention.

[0050] FIG. 6c is a semi-transparent view of a spacer with wings in a deployed and extended configuration according to the present invention.

[0051] FIG. 7 is a partial cross-sectional view of a spacer according to the present invention located between two adjacent spinous processes.

[0052] FIG. 8 is a cross-sectional view of a spacer according to the present invention located between two adjacent spinous processes.

[0053] FIG. 9 is a cross-sectional view of a spacer according to the present invention located between two adjacent spinous processes.

[0054] FIG. 10 is a partial view of a spacer according to the present invention.

[0055] FIG. 11 is a partial view of a spacer and driving tool according to the present invention.

[0056] FIG. 12 is a posterior view of part of a spine with a scoliotic curve.

[0057] FIG. 13a is a side view of a spacer connected to an insertion instrument according to the present invention.

[0058] FIG. 13b is a side view of a spacer in a partially deployed configuration connected to an insertion instrument according to the present invention.

[0059] FIG. 13c is a side view of a spacer in a deployed configuration connected to an insertion instrument according to the present invention.

[0060] FIG. 13d is a side view of a spacer in a deployed and extended configuration connected to an insertion instrument according to the present invention.

[0061] FIG. 14 is a perspective view of a spacer in a deployed configuration according to the present invention implanted between adjacent spinous processes of two vertebral bodies.

DETAILED DESCRIPTION

[0062] With reference to FIGs. 1a-1f, various views of a spacer 10 according to the present invention are shown. The spacer 10 includes a body 12, a superior extension member, arm or wing 14, an inferior extension member, arm or wing 16, and an actuator assembly 18.

[0063] Turning now to FIGs. 2a-2d, the body will now be described. The body 12 is shown to have a clamshell construction with a left body piece 20 (shown in FIGs. 2a and 2b) joined to a right body piece 22 (shown in FIGs. 2c and 2d) to capture arms 14, 16 inside. With the right and left body pieces 20, 22 joined together, the body 12 is generally cylindrical. The spacer body 12 has a cross-sectional size and shape that allows for implantation between adjacent spinous processes and facilitates delivery into a patient through a narrow port or cannula.

[0064] The inside of the body 12 defines an arm receiving portion 24 and an actuator assembly receiving portion 26 with features formed in each of the left and right body pieces 20, 22 that together define the arm and actuator assembly receiving portions 24, 26. In one variation, the arm receiving portion 24 includes slots 28 that receive pins formed on the arms 14, 16 such that the pins rotate and/or translate inside the slots 28. The actuator assembly receiving portion 26 includes a threaded passageway 30. Other features include a tongue and groove for mating with the opposite clamshell.

[0065] The outside of the body 12 defines a ledge 32 along at least a portion of the periphery. Notches 34 are formed at opposite locations and are configured for pronged attachment to a spacer delivery instrument. When joined together, the left and right body pieces 20, 22 define a proximal opening 36 (as also seen in FIG. 1e) and a distal opening 38 (as also seen in FIG. 1a) in the body 12. A longitudinal scallop (not shown) extending from the proximal end of the spacer to the distal end is formed to facilitate placement of the spacer 10 between and to conform to the anatomy of adjacent spinous processes. In one variation, two oppositely located longitudinal scallops are formed in the outer surface of the body 12 such that, when implanted in a patient's spine, one scallop faces the superior spinous process and the other scallop faces the inferior spinous process. In one variation, the distance between oppositely located longitudinal scallops is approximately 8.0 millimetres imparting the spacer

10 with a low profile advantageous for insertion between closely spaced or "kissing" spinous processes.

[0066] Turning now to FIGs. 3a-3c, the superior arm 14 is shown and in FIGs. 3d-3f, the inferior arm 16 is shown. The superior and inferior arms 14, 16 include pins 40 for mating with the body 12, in particular, for mating with the slots 28 of the arm receiving portion 24. Each of the superior and inferior arms 14, 16 includes at least one camming surface 41, 43, respectively, for contact with the actuator assembly 18.

[0067] The superior and inferior arms 14, 16 include elongated superior extensions 42a, 42b and elongated inferior extensions 44a, 44b, respectively. Extensions 42a and 44a are located on the left adjacent to the left body piece 20 and extensions 42b and 44b are located on right adjacent to the right body piece 22. Superior extensions 42a, 42b extend substantially parallel to each other in both an undeployed configuration and in a fully-deployed configuration as do inferior extensions 44a, 44b. Extending between extensions 42a, 42b is a strut, bridge, bracket or saddle 46 that forms a superior substantially U-shaped configuration that is sized and configured to receive a superior spinous process. As seen in FIG. 3c, the anterior face of the superior extensions 14 includes a slight concavity or curvature 45 for conforming to the bony anatomy of the superior spinous process and or lamina. Extending between inferior extensions 44a, 44b is a strut, bridge, bracket or saddle 48 that forms an inferior substantially U-shaped configuration that is sized and configured to receive an inferior spinous process of a spinal motion segment. As seen in FIG. 3f, the anterior face of the inferior extensions 16 includes a slight convexity or curvature 47 for conforming to the bony anatomy of the inferior spinous process and/or lamina. In one variation, the length of the saddle 46 of the superior arm 14 is approximately 9.0 millimetres and the length of the saddle 48 of the inferior arm 16 is approximately 7.0 millimetres.

[0068] Also, the tip-to-tip distance of the superior extensions 42a, 42b is approximately 10.0 millimetres and the tip-to-tip distance of the inferior extensions 44a, 44b is approximately 9.0 millimetres. In sum, the seat comprising the saddle 46 and superior extensions 42a, 42b formed by the superior arm 14 is larger than the seat comprising the saddle 48 and inferior extensions 44a, 44b formed by the inferior arm 16. The larger superior seat of the spacer conforms closely to a wider lower end of the spinous process and the smaller inferior seat of the spacer conforms closely to a narrower upper end of the adjacent inferior spinous process when the spacer 10 is inserted between adjacent spinous processes as spinous processes are

naturally narrower on top and wider on the bottom and thereby providing greater lateral stability to the spacer with respect to the spinous processes.

[0069] The superior and inferior arms 14, 16 are movably or rotatably connected to the body 12, for example by hinge means or the like to provide rotational movement from an undeployed configuration to a deployed configuration that arcs through about a 90 degree range or more with respect to the body 12. The arms 14, 16 are rotationally movable between at least an undeployed, collapsed or folded state (as shown in FIGs. 1a-1e) and at least a fully deployed state (as shown in FIGs. 4c, 5c and 6c). In the undeployed state, the arm pairs 14, 16 are aligned generally or substantially axially (i.e., axially with the longitudinal axis defined by the body 12 or to the translation path into the interspinous space of the patient) to provide a minimal lateral or radial profile. The longitudinal axis X of the spacer 10 and body 12 is shown in FIG. 1c. In the deployed state, the arm pairs 14, 16 are positioned generally or substantially transverse to the collapsed position (i.e., transverse to the longitudinal axis defined by the body 12 or to the translation path into the interspinous space of the patient). In the deployed state, the arm pairs 14, 16 are positioned such that each of the U-shaped saddles are in a plane (or individual planes) or have a substantially U-shaped projection in a plane that is generally or substantially transverse to the longitudinal axis X defined by the body 12 or to the collapsed position or to the implantation path into the interspinous space of the patient. In one variation, the spacer 10 is configured such that the arms 14, 16 are linearly moveable or translatable within the same transverse plane from the deployed state (such as the state shown in FIGs. 4c, 5b and 6b) to and from an additionally extended state or second deployed state (such as the state shown in FIGs. 4d, 5c and 6c) characterized by an additional translation of at least one of the arms 14, 16 with respect to the body 12 along the direction of the arrows in FIG. 4d and 6c away from or towards the body 12. More specifically, the arms 14, 16 can be extended in the general vertical or lateral direction along an axis along the general length of the spine wherein the arms 14, 16 are extended away from each other and away from the body 12 as denoted by the arrows in FIG. 4d. The arms 14, 16 can be unextended in a direction towards each other and towards the body 12 for un-deployment or repositioning of the spacer 10 and shown by the arrows in FIG. 6c. This extended feature advantageously allows for the most minimally invasive configuration for the spacer without compromising the ability of the spacer 10 to seat and contain the spinous processes or to laterally stabilize the spacer relative to the spinous processes in between levels where the anatomy of the spinous processes is such that the interspinous process space increases in the anterior direction of the patient or without compromising the ability of the spacer to provide adequate distraction. The arms 14, 16 are connected to the body 12 and/or to each other in a

manner that enables them to be moved simultaneously or independently of each other, as well as in a manner that provides passive deployment and/or vertical extension or, alternatively, active or actuated deployment and/or vertical extension.

[0070] Turning back to FIG. 1f, the actuator assembly 18 will now be described. The actuator assembly 18 includes an actuator 48, shaft 50 and retainer 52. The actuator 48 includes a distal end 54 and a proximal end 56 and at least two bearing surfaces 58. The bearing surfaces 58 angle towards each other from the proximal end 56 to the distal end 54. The proximal end 56 of the actuator 48 includes a shaft receiving portion 60 configured to receive the shaft 50. In one variation, the shaft 50 is integrally formed with the actuator 48. The distal end 54 of the actuator 48 is further configured to engage the superior and inferior arms 14, 16 such that forward translation of the actuator 48 relative to the body 12 effects deployment of the arms into at least one deployed configuration. The actuator assembly 18 is at least partially disposed inside the body 12 and is configured to move with respect to the body 12.

[0071] Still referencing FIG. 1, the shaft 50 is substantially cylindrical in shape and includes a threaded outer surface for engagement with the threaded inner surface of the actuator assembly receiving portion 26 of the body 12. The threads on the inner surface of the body 12 are formed by the conjunction of both left and right body pieces 20, 22. The proximal end of the shaft 50 includes a hex socket 62 for receiving a driving tool. The distal end of the shaft 50 includes an actuator engagement portion 64 configured to connect to the actuator 48. The actuator engagement portion 64 as shown in FIG. 1 is a projection that slides into a channel 66 on the actuator 48. Once inserted into the channel 66, movement of the shaft 50 solely along the longitudinal axis of the spacer 10 will not release the shaft 50 from the actuator 48.

[0072] Still referencing FIG. 1, the retainer 52 is a circular ring preferably made of metal such as steel or titanium. The retainer 52 fits into a recess 68 formed on the inner surface of the body 12. When pressed into the recess 68, the retainer 52 secures the actuator 48 inside the passageway 30 of the body 12.

[0073] Assembly of the spacer 10 with reference to FIGs. 1a-1f will now be described. The arms 14, 16 are disposed in the arm receiving portion 24 of one body piece. The other of the left or right body piece 20, 22 is securely connected/welded to the one body piece thereby capturing the arms 14, 16 inside the arm receiving portion 24 such that the arms 14, 16 are capable of at least rotational movement with respect to the body 12 and in one variation,

capable of rotational movement and translation with respect to the body 12. The shaft 50 is connected to the actuator 48 and together inserted and threadingly connected into the passageway 30 of the body 12. The retainer 52 is passed over the proximal end of the shaft 50 and snapped into the recess 68 of the body 12 to secure the actuator assembly 18 inside the body 12 such that the actuator assembly 18 is capable of threaded translational movement with respect to the body 12.

[0074] To deliver and deploy the spacer 10 within the patient, the spacer 10 is releasably attached to a delivery instrument (not shown) at the proximal end of the spacer 10 via notches 34. The spacer 10 is provided or otherwise placed in its undeployed state as illustrated in FIG. 4a. In the undeployed state and attached to a delivery instrument, the spacer 10 is inserted into a port or cannula which has been operatively positioned in an interspinous space within a patient's back and the outside of the patient via a minimally invasive incision. In some circumstances it may not be necessary to use a cannula where the device is inserted through a larger opening in the skin. Where a cannula is employed, the spacer 10 is then advanced through the cannula to within the targeted interspinous space between two adjacent spinous processes. The spacer 10 is advanced beyond the end of the cannula or, alternatively, the cannula is pulled proximally to uncover the spacer 10 within. A driver such as a hex-shaped tool is inserted into the hex socket 62 of the spacer 10 and turned to advance the shaft 50 of the actuator assembly 18. As the shaft 50 advances within the passageway 30, the bearing surfaces 58 of the actuator 48 contact the superior and inferior camming surfaces 41, 43 of the superior and inferior arms 14, 16 forcing the arms 14, 16 to rotate about their pins 40 with respect to the body 12. The arms 14, 16 rotate through an arc of approximately 90 degrees into the deployed configuration in which the superior and inferior extensions 42a, 42b, 44a, 44b are substantially perpendicular to the longitudinal axis of the spacer 10 as shown in FIGs. 4c and 4d. In one variation, continued advancement of the actuator assembly 18 forces the arms 14, 16 outwardly in the direction of the arrows in FIG. 4d. Such outward translation is guided by the length and shape of the slots 28. Once deployed, the superior arm 14 seats the superior spinous process and the inferior arm 16 seats the adjacent inferior spinous process.

[0075] Referring now to FIGs. 4a-4d, the spacer 10 is shown in a closed, undeployed configuration (FIG. 4a), a partially deployed configuration or otherwise intermediary configuration (FIG. 4b), a deployed configuration (FIG. 4c) and a deployed and extended configuration (FIG. 4d). In FIGs. 4a-4d, the sagittal plane of the spacer 10 corresponds to the plane of the paper that bisects the spacer 10. In moving from an undeployed to a deployed configuration, the actuator assembly 18 and, in particular, the shaft 50 of the actuator

assembly moves distally with respect to the body to a position flush or almost flush with the proximal end of the body 12 or to a position completely inside the body 12 disappearing from sight providing a low profile for the spacer 10 along the longitudinal axis of the body 12.

[0076] Turning now to the cross-sectional views of the spacer 10 in FIGs. 5a-5c, as the shaft 50 advances within the passageway 30, the bearing surfaces 58 of the actuator 48 contact the superior and inferior camming surfaces 41, 43 of the superior and inferior arms 14, 16 turning the arms 14, 16 into rotation with respect to the body 12. Upon rotation, the bearing surfaces 58 of the actuator 48 slide with respect to the superior and inferior camming surfaces 41, 43 of the superior and inferior arms 14, 16. The arms 14, 16 rotate through an arc of approximately 90 degrees with respect to the body 12 into the deployed configuration (FIG. 5b) in which the superior and inferior extensions of the arms 14, 16 are substantially perpendicular to the longitudinal axis of the spacer 10 as shown in FIGs. 5b and with further actuation into a deployed and extended configuration as shown in FIG. 5c in which the arms 14, 16 have extended outwardly away from the body 12. The arms 14, 16 have a substantially U-shaped projection in a plane perpendicular to the longitudinal axis of the spacer 10 or a substantially U-shaped projection in a plane perpendicular to the longitudinal axis of the spacer 10.

[0077] Turning now to the semi-transparent views of the spacer 10 in FIGs. 6a-6c, the rotation of the pins 40 of the arms 14, 16 in the openings 28 of the body 12 is shown in moving from the configuration of FIG. 6a to the configuration of FIG. 6c. The translation of the pins 40 of the arms 14, 16 in the elongated portion of the slots 28 of the body 12 is shown in moving from the deployed configuration of FIG. 6b to the deployed and extended configuration of FIG. 6c in the direction of the arrows in FIG. 6c. Such outward translation with respect to the body 12 is guided by the length and shape of the slots 28. Reverse rotation of the spindle 86 moves the shaft 50 proximally with respect to the body 12 allowing the arms to close to any intermediary configuration between a deployed, configuration and an undeployed, closed configuration. This feature advantageously permits the surgeon to deploy and undeploy the spacer as needed to ease installation and positioning of the spacer with respect to patient anatomy.

[0078] Any of the spacers disclosed herein are configured for implantation employing minimally invasive techniques including through a small percutaneous incision and through the supraspinous ligament. Implantation through the supraspinous ligament involves selective dissection of the supraspinous ligament in which the fibres of the ligament are cut, separated or spread apart from each other in a manner to maintain as much of the ligament intact as

possible such as cutting, separating or spreading in a direction parallel to the orientation of the ligament fibres. This approach avoids crosswise dissection or cutting of the ligament and thereby reduces the healing time and minimizes the amount of instability to the affected spinal segment. While this approach is ideally suited to be performed through a posterior or midline incision, the approach may also be performed through one or more incisions made laterally of the spine with or without affect to the supraspinous ligament. Of course, the spacer may also be implanted in a lateral approach that circumvents the supraspinous ligament altogether.

[0079] Other variations and features of the various mechanical spacers are covered by the present invention. For example, a spacer may include only a single arm which is configured to receive either the superior spinous process or the inferior spinous process or laterally stabilize the body of the spacer with respect to the superior spinous process and/or with respect to the inferior spinous process. The surface of the spacer body opposite the side of the single arm may be contoured or otherwise configured to engage the opposing spinous process wherein the spacer is sized to be securely positioned in the interspinous space and provide the desired distraction of the spinous processes defining such space. The additional extension of the arm(s) subsequent to their initial deployment in order to seat or to effect the desired distraction between the vertebrae may be accomplished by expanding the body portion of the device instead of or in addition to extending the individual extension members 14, 16.

[0080] The extension arms of the subject device may be configured to be selectively movable subsequent to implantation, either to a fixed position prior to closure of the access site or otherwise enabled or allowed to move in response to normal spinal motion exerted on the device after deployment. The deployment angles of the extension arms may range from less than 90 degrees (relative to the longitudinal axis defined by the device body) or may extend beyond 90 degrees. Each extension member may be rotationally movable within a range that is different from that of the other extension members. Additionally, the individual superior and/or inferior extensions 42a, 42b, 44a, 44b may be movable in any direction relative to the strut or bridge extending between an arm pair or relative to the device body in order to provide shock absorption and/or function as a motion limiter, or serve as a lateral adjustment particularly during lateral bending and axial rotation of the spine. The manner of attachment or affixation of the extensions to the arms may be selected so as to provide movement of the extensions that is passive or active or both. In one variation, the saddle or distance between extensions 42a and 42b or between 44a and 44b can be made wider to assist in seating the spinous process and then narrowed to secure the spinous process positioned between

extensions 42a and 42b or between 44a and 44b. Spacers having different arm 14, 16 configurations will now be discussed.

[0081] Turning now to FIGs. 7-11, there is shown another variation of the spacer 10 according to the present invention wherein like numerals are used to describe like parts. The spacer 10 of FIGs. 7-11 is adapted for implantation into patients with adjacent spinous processes that are misaligned such as patients with scoliosis where the spine curves laterally forming an S-shaped or C-shaped curve. With reference to FIG. 12, there is shown a scoliotic spine. Cobb's angle is a measurement used for evaluation of curves in scoliosis on an anterior-posterior projection of the spine as shown in FIG. 12. When assessing a curve of the spine, the apical vertebra is first identified. The apical vertebra is the most likely displaced and rotated vertebra with the least tilted end plate. The end/transitional vertebra are then identified through the curve above and below. The end vertebrae are the most superior and inferior vertebrae which are least displaced and rotated and have the maximally tilted end plate. As shown in FIG. 12, a line is drawn along the superior end plate of the superior end vertebra and a second line drawn along the inferior end plate of the inferior end vertebra. If the end plates are indistinct the line may be drawn through the pedicles. The angle between these two lines (or lines drawn perpendicular to them) is measured as the Cobb angle. In S-shaped scoliosis where there are two contiguous curves the lower end vertebra of the upper curve will represent the upper end vertebra of the lower curve. Because the Cobb angle reflects curvature only in a single plane and fails to account for vertebral rotation it may not accurately demonstrate the severity of three dimensional spinal deformity. Generally, a Cobb angle of 10 is regarded as a minimum angulation to define scoliosis. In a normal spine the spinous processes of the spine are substantially aligned and lie in one plane, which for practical purposes will be defined as a sagittal plane. In particular, the projection of the spinous processes on a coronal plane will be substantially aligned with the sagittal plane. In a scoliotic spine, the spinous processes are angle with respect to the sagittal plane. In particular, the anterior-posterior projection of the spinous processes on a coronal plane will show at least one spinous process angled with respect to the sagittal plane.

[0082] FIG. 7 shows an anterior-posterior view of a partially cross-sectioned superior spinous process 108 and an adjacent inferior spinous process 110 between which the spacer 10 is implanted in a portion of a spine showing a scoliotic curve C convex to the left. The spacer 10 of FIG. 7 includes superior and inferior arms 14, 16 adapted to a scoliotic curve C that is convex to the left. The remaining components of the spacer 10 such as the body 12 and

actuator assembly 18 are similar if not identical to the same components described above with respect to FIGs. 1-6.

[0083] The superior and inferior arms 14, 16 include elongated superior extensions 42a, 42b and elongated inferior extensions 44a, 44b respectively. Extensions 42a and 44a are located on the left and extensions 42b and 44b are located on the right.

[0084] Superior extensions 42a, 42b extend substantially parallel to each other in both an undeployed configuration and fully deployed configuration as do inferior extensions 44a, 44b. As shown, extensions 42a, 42b, 44a, 44b are substantially parallel to the Y axis.

[0085] Extending between superior extensions 42a, 42b is a strut, bridge, bracket or saddle 46 that, together with superior extensions 42a, 42b, form a superior receiving portion or seat that is sized and configured to laterally stabilize the body 12 with respect to the superior spinous process 108 and in one variation configured to receive at least a portion of a superior spinous process 108. In previous embodiments described above, when in the fully deployed configuration, the bridge 46 is substantially perpendicular to the superior extensions 42a, 42b and substantially parallel to the X-Z plane where Z corresponds to the longitudinal axis of the spacer 10 extending into and out of the page. In the embodiment shown in FIG. 7, the bridge 46 is angled with respect to the superior extensions 42a, 42b to adapt to the convex left scoliotic curve C. The angled bridge 46 is integrally formed with the superior arm 14 or alternatively, the bridge 46 is a wedge-shaped insert adapted to modify a spacer 10 into a spacer 10 having an angled bridge 46. The plane of the bridge 46 in the transverse or X-Y plane forms an angle θ with the Y-Z plane that is between 0 and 90 degrees, preferably between 5 and 60 degrees.

[0086] The Y-Z plane, where Z corresponds to the longitudinal axis of the spacer 10 extending into and out of the page, is the sagittal plane of the spacer 10 and it may or may not correspond to the sagittal plane of the patient's body or spine. FIG. 7 shows the superior spinous process 108 and inferior spinous process 110 angled with respect to the sagittal plane with extensions 42 and 44 being substantially parallel to the sagittal plane.

[0087] Extending between inferior extensions 44a, 44b is a strut, bridge, bracket or saddle 48 that, together with inferior extensions 44a, 44b, form an inferior receiving portion that is sized and configured to laterally stabilize the body 12 with respect to the inferior spinous process 110 and in one variation configured to receive at least a portion of an adjacent inferior

spinous process 110. In previous embodiments described above, when in the fully deployed configuration, the bridge 48 is substantially perpendicular to the inferior extensions 44a, 44b and substantially parallel to the X-Z plane where Z corresponds to the longitudinal axis of the spacer 10 extending into and out of the page. In the embodiment shown in FIG. 7, the bridge 48 is angled with respect to the inferior extensions 44a, 44b or angle with respect to the sagittal plane to adapt to the convex left scoliotic curve C. The angled bridge 48 is integrally formed with the inferior arm 16 or alternatively, the bridge 48 is a wedge-shaped insert adapted to modify a spacer 10 into a spacer 10 having an angled bridge 48. The plane of the bridge 48 in the transverse or X-Y plane forms an angle θ with the Y-Z plane or sagittal plane that is between 0 and 90 degrees, preferably between 5 and 60 degrees.

[0088] As shown in FIG. 7, the angled bridges 46, 48 conform the spacer 10 to the scoliotic curve such that the superior and inferior spinous processes 108, 110 are seated in the superior and inferior arms 14, 16, or receiving portion of those arms, respectively, when in the deployed configuration. In another variation, the right superior extension 42b is slightly shorter in length relative to the left superior extension 42a to better accommodate the angled superior spinous process in a convex left scoliotic curve as shown in FIG. 7. Also, the right inferior extension 44b is slightly shorter in length relative to the left inferior extension 44a to better accommodate the angled inferior spinous process in the convex left scoliotic curve. Furthermore, only one of the bridges 46, 48 need be angled.

[0089] Turning now to FIG. 8, there is shown another variation of the spacer 10 according to the present invention wherein like numerals are used to describe like parts. The spacer 10 of FIG. 8 is adapted for implantation into patients with adjacent spinous processes that are misaligned such as patients with scoliosis where the spine curves laterally forming an S-shaped or C-shaped curve. FIG. 8 shows a superior spinous process 108 and an adjacent inferior spinous process 110 between which the spacer 10 is implanted in a portion of a spine showing a scoliotic curve C convex to the right. The spacer 10 of FIG. 8 includes superior and inferior arms 14, 16 configured to a scoliotic curve C that is convex to the right. The remaining components of the spacer 10 such as the body 12 and actuator assembly 18 of the spacer 10 are similar if not identical to the same components described above with respect to FIGs. 1-6.

[0090] The superior and inferior arms 14, 16 include elongated superior extensions 42a, 42b and elongated inferior extensions 44a, 44b, respectively. Extensions 42a and 44a are located on the left and extensions 42b and 44b are located on the right.

[0091] Superior extensions 42a, 42b extend substantially parallel to each other in both an undeployed configuration and fully deployed configuration as do inferior extensions 44a, 44b.

[0092] Still referencing FIG. 8, extending between superior extensions 42a, 42b is a strut, bridge, bracket or saddle 46 that, together with superior extensions 42a, 42b, form a superior receiving portion that is sized and configured to laterally stabilize the body 12 with respect to the superior spinous process 108 and in one variation receive a superior spinous process 108. As shown, extensions 42a, 42b, 44a, 44b are substantially parallel to the Y-Z plane. In previous embodiments described above, the bridge 46 is substantially perpendicular to the superior extensions 42a, 42b and substantially parallel to the X-Z plane where Z corresponds to the longitudinal axis of the spacer 10 extending into and out of the page. In the embodiment shown in FIG. 8, the bridge 46 is angled with respect to the superior extensions 42a, 42b to adapt to the convex right scoliotic curve C. The angled bridge 46 is integrally formed with the superior arm 14 or alternatively, the bridge 46 is a wedge-shaped insert adapted to modify a spacer 10 into a spacer 10 having an angled bridge 46. The plane of the bridge 46 in the transverse or X-Y plane forms an angle θ with the Y-Z plane or sagittal plane that is between 90 and 180 degrees, preferably between 120 and 175 degrees.

[0093] Extending between inferior extensions 44a, 44b is a strut, bridge, bracket or saddle 48 that, together with inferior extensions 44a, 44b, form an inferior receiving portion that is sized and configured to laterally stabilize the body 12 with respect to the inferior spinous process 110 and in one variation to receive an adjacent inferior spinous process 110. In previous embodiments described above, the bridge 48 is substantially perpendicular to the inferior extensions 44a, 44b and substantially parallel to the X-Z plane where Z corresponds to the longitudinal axis of the spacer 10 extending into and out of the page. In the embodiment shown in FIG. 8, the bridge 48 is angled with respect to the inferior extensions 44a, 44b to adapt the spacer 10 to the convex right scoliotic curve C. The angled bridge 48 is integrally formed with the inferior arm 16 or alternatively, the bridge 48 is a wedge-shaped insert adapted to modify a spacer 10 into a spacer 10 having an angled bridge 48. The plane of the bridge 48 in the transverse or X-Y plane forms an angle θ with the Y-Z plane that is between 90 and 180 degrees, preferably between 120 and 175 degrees.

[0094] As shown in FIG. 8, the angled bridges 46, 48 conform to the scoliotic curve such that the superior and inferior spinous processes 108, 110 are seated in the superior and inferior arms 14, 16, respectively, when in the deployed configuration. In another variation, the left superior extension 42a is slightly shorter in length relative to the right superior extension

42b to better accommodate the angled superior spinous process in a convex right scoliotic curve as shown in FIG. 8. Also, the left inferior extension 44a is slightly shorter in length relative to the right inferior extension 44b to better accommodate the angled inferior spinous process in a convex right scoliotic curve.

[0095] Turning now to FIG. 9, there is shown another variation of the spacer 10 according to the present invention wherein like numerals are used to describe like parts. The spacer 10 of FIG. 9 is adapted for implantation into patients with adjacent spinous processes that are misaligned such as patients with scoliosis where the spine curves laterally forming an S-shaped or C-shaped curve. FIG. 9 shows a superior spinous process 108 and an adjacent inferior spinous process 110 between which the spacer 10 is implanted in a portion of a spine showing a scoliotic curve C convex to the left. The spacer 10 of FIG. 9 includes superior and inferior arms 14, 16 adapted to a scoliotic curve C that is convex to the left in which the superior and inferior arms 14, 15 are angled. The spacer 10 may also be configured with superior and inferior arms 14, 16 adapted to a scoliotic curve C that is convex to the right in which the superior and inferior arms, 14, 15 are angled in the opposite direction. The remaining components such of the spacer 10 as the body 12 and actuator assembly 18 of the spacer 10 are similar if not identical to the same components described above with respect to FIGs. 1-6.

[0096] Still referencing FIG. 9, the superior and inferior arms 14, 16 include elongated superior extensions 42a, 42b and elongated inferior extensions 44a, 44b respectively. Extensions 42a and 44a are located on the left and extensions 42b and 44b are located on the right. Superior extensions 42a, 42b extend substantially parallel to each other in both an undeployed configuration and fully deployed configuration as do inferior extensions 44a, 44b.

[0097] In the variation of FIG. 9, the superior extensions 42a, 42b are angled such that the superior extensions 42a, 42b form an angle θ with respect to the Y-Z plane or sagittal plane when in the deployed configuration where Z corresponds to the longitudinal axis of the spacer 10 extending into and out of the page. The angle θ is between 0 and 90 degrees, preferably between 5 and 75 degrees. Likewise, inferior extensions 44a, 44b are also angled such that the inferior extensions 44a, 44b form an angle θ with the Y-Z plane when in the deployed configuration. The angle θ is between 0 and 90 degrees, preferably between 5 and 75 degrees. The superior arm 14 extensions 42a, 42b need not have the same angle θ as the inferior arm 16 extensions 44a, 44b.

[0098] Still referencing FIG. 9, extending between superior extensions 42a, 42b is a strut, bridge, bracket or saddle 46 that, together with superior extensions 42a, 42b, form a superior receiving portion that is sized and configured laterally stabilize the body 12 with respect to the superior spinous process 108 and in one variation to receive a superior spinous process 108. The bridge 46 is substantially perpendicular to the superior extensions 42a, 42b. In the embodiment shown in FIG. 10, the plane of the bridge 46 in the X-Y plane is angled with respect to the X-Z plane or sagittal plane by the angle θ that is between 0 and 90 degrees, preferably between 5 and 75 degrees to adapt to the scoliotic curve convex to the left.

[0099] Extending between inferior extensions 44a, 44b is a strut, bridge, bracket or saddle 48 that, together with inferior extensions 44a, 44b, form an inferior receiving portion that is sized and configured to laterally stabilize the body 12 with respect to the inferior spinous process 110 and in one variation to receive an adjacent inferior spinous process 110. The bridge 48 is substantially perpendicular to the inferior extensions 44a, 44b. In the embodiment shown in FIG. 9, the plane of the bridge 48 in the X-Y plane is angled with respect to the X-Z plane by an angle θ that is between 0 and 90 degrees, preferably between 5 and 75 degrees to adapt to the scoliotic curve convex to the left. As shown in FIG. 9, the angled bridges 46, 48 conform to the scoliotic curve such that the superior and inferior spinous processes 108, 110 are received in the superior and inferior arms 14, 16, respectively, when in the deployed configuration.

[0100] Turning now to FIGs. 10 and 11, there is shown a partial anterior-posterior view of a spacer 10 illustrating a portion of the body 12 and an inferior arm 16. The spacer 10 of FIG. 10 includes at least one arm that articulates in the direction of the arrows to accommodate a convex right or convex left scoliotic curve of varying degrees. Only the inferior arm is shown in FIGs. 10 and 11. The angle θ that the bridge 48 in the X-Y plane makes with respect to the Y-Z plane or sagittal plane where Z corresponds to the longitudinal axis of the spacer 10 extending into and out of the page is adjusted and locked by a driving tool 112 shown in FIG. 11 and configured to angulate the superior arm 14 and/or inferior arm 16 as desired so that the superior arm 14 seats the superior spinous 108 process and the inferior arm 16 seats the inferior spinous process 110.

[0101] The spacer 10 of FIGs. 7-11 are delivered and deployed within the patient in the same manner as described above with respect to FIGs. 1-6. The spacers 10 of FIGs. 9-11 that are angled before delivery into the patient require the clinician to angle the spacer 10 during delivery into the interspinous space. For example, when in the undeployed configuration,

spacer 10 of FIG. 9 or the spacer 10 of FIGs. 10 and 11 that is angled before delivery, requires insertion first along a path parallel to the superior and inferior extensions 42a, 42b, 44a, 44b. The spacer 10 is then turned such that the body 12 trailing the extensions is oriented parallel to the same path so that the extensions conform to the scoliotic curvature. Otherwise, the delivery and deployment of the spacer 10 proceeds as described herein.

[0102] The spacer 10 is provided or otherwise placed in its undeployed, closed state in juxtaposition to the insertion instrument 80 and connected thereto as shown in FIG. 13a. The longitudinal axis of the insertion instrument 80 is advantageously aligned with the longitudinal axis of the spacer 10 as shown. The delivery instrument 80 includes a first subassembly 102 to releasably clamp to the body 12 of the spacer 10 at a distal end of the insertion instrument 80. The first subassembly 102 includes an inner clamp shaft (not shown) having flexible prongs 126 at the distal end configured for attachment to the body 12 of the spacer 10 and, in particular, for insertion into the notches 34 of the spacer body 12. The first subassembly 102 includes an outer shaft 112 located over the inner clamp shaft and configured for relative motion with respect to one another via a control 114 located at the handle assembly 106. The control 114 is threaded to the outer shaft 112 such that rotation of the control 114 moves the outer shaft 112 along the longitudinal axis of the insertion instrument 80 over the inner clamp shaft to deflect and undeflect the prongs 126 to connect or disconnect the instrument 80 to or from the body 12. The first control 114 is activated at the handle of the insertion instrument 80 such that the first subassembly 102 is connected to the body 12 of the spacer 10. The first control 114 is rotated in one direction to advance the outer shaft 112 over the inner clamp shaft (not shown) deflecting the prongs 126 inwardly into the notches 34 on the body 12 of the spacer 10 to secure the spacer body 12 to the instrument as shown in FIG. 13a. Reverse rotation of the control 114 reverses the direction of translation of the outer shaft 112 to release the prongs 126 from the notches 34 and, thereby, release the spacer 10 from the instrument 80.

[0103] Still referencing FIG. 13a, the insertion instrument 80 includes a second subassembly 104 that is configured to connect to the actuator assembly 18 of the spacer 10. In particular, the second subassembly 104 includes means located at the distal end of the second subassembly 104 to activate the actuator assembly 18. In one variation, the second subassembly 104 is a pronged driver having an elongated shaft that is configured to be insertable into the notches of a spindle. In another variation, the second subassembly 104 is an elongated shaft with hexagonally-shaped tip configured to be insertable into a corresponding hexagonally shaped socket 62 of the shaft 50. The second subassembly 104 is

insertable at the proximal end of the instrument 80 and extends through the handle assembly 106 and through the inner.

[0104] The removable driver 104 is rotatable with respect to the instrument 80 to rotate the shaft 50 and arrange the spacer 10 to and from deployed and undeployed configurations.

[0105] To deliver and deploy the spacer 10 within the patient, the spacer 10 is releasably attached to a delivery instrument 80 at the proximal end of the spacer 10 as shown in FIG. 13a. A small midline or lateral-to-midline incision is made in the patient for minimally-invasive percutaneous delivery. In one variation, the supraspinous ligament is avoided. In another variation, the supraspinous ligament is split longitudinally along the direction of the tissue fibres to create an opening for the instrument. Dilators may be further employed to create the opening. In the undeployed state with the arms 14, 16 in a closed orientation and attached to a delivery instrument 80, the spacer 10 is inserted into a port or cannula, if one is employed, which has been operatively positioned to an interspinous space within a patient's back and the spacer is passed through the cannula to the interspinous space between two adjacent vertebral bodies. The spacer 10 is advanced beyond the end of the cannula or, alternatively, the cannula is pulled proximally to uncover the spacer 10 connected to the instrument 80. Once in position, the second assembly 104 is inserted into the instrument 80 if not previously inserted to engage the actuator and is rotated to rotate the shaft 50. The rotating shaft 50 advances the actuator 48 to begin deployment the spacer 10. Rotation in one direction, clockwise, for example, threadingly advances the shaft 50 which then results in the actuator 48 contacting the superior and inferior camming surfaces 41, 43 of the superior and inferior arms 14, 16 to begin their deployment. FIG. 13b illustrates the superior arm 14 and the inferior arm 16 in a partially deployed position with the arms 14, 16 rotated away from the longitudinal axis. The position of the arms 14, 16 in FIG. 13b may be considered to be one of many partially deployed configurations or intermediary configurations that are possible and from which the deployment of the arms 14, 16 is reversible with opposite rotation of the second assembly 104. With further advancement, the arms 14, 16 rotate through an arc of approximately 90 degrees into the deployed configuration in which the superior and inferior extensions are substantially perpendicular to the longitudinal axis of the spacer 10 as shown in FIG. 13c.

[0106] Turning to FIG. 13c, there is shown an insertion instrument 80 connected to a spacer 10 in a first deployed configuration in which the arms 14, 16 are approximately 90 degrees perpendicular to the longitudinal axis or perpendicular to the initial undeployed configuration. Continued rotation of second assembly 104 rotates the shaft 50 further distally with respect to

the body 12 of the spacer 10 pushing the bearing surfaces 58 further against the superior and inferior camming surfaces 41, 43. While in the first deployed configuration of FIG. 13c, the clinician can observe with fluoroscopy the positioning of the spacer 10 inside the patient and then choose to reposition the spacer 10 if desired. Repositioning of the spacer 10 may involve undeploying the arms 14, 16 by rotating the shaft 50 via the second assembly 104 to rotate the arms into any one of the many undeployed configurations and then moving the delivery instrument while connected to the spacer into a new position.

[0107] The spacer wings may then be re-deployed into the desired location. This process can be repeated as necessary with or without undeployment of the wings until the clinician has achieved the desired positioning of the spacer in the patient. Of course, inspection of the spacer 10 may be made via fluoroscopy while the spacer 10 is in an intermediate or partially deployed configuration such as that of FIG. 13b.

[0108] Even further advancement of the actuator shaft 50 via rotation of the second subassembly 104 from the first deployed configuration results in the spacer 10 assuming a second deployed configuration shown in FIG. 13d, if the spacer 10 is so configured as to allow a second deployed configuration. The second deployed configuration is an extended configuration as described above in which the superior and inferior arms 14, 16 extend transversely with respect to the longitudinal axis outwardly in the direction of the arrows in FIG. 4d. The spacer 10 is configured such that the outward translation of the arms 14, 16 follows the rotation into 90 degrees and is guided by the length and shape of the openings 28 in which the arms 14, 16 move. Once deployed, the superior arm 14 seats the superior spinous process and the inferior arm 16 seats the adjacent inferior spinous process. Such extension may also provide some distraction of the vertebral bodies.

[0109] Following deployment, the second assembly 104 may be removed. Control 114 is rotated in the opposite direction to release the body 12 from the instrument 80. The insertion instrument 80, thus released from the spacer 10, is removed from the patient leaving the spacer 10 implanted in the interspinous process space as shown in FIG. 14. In FIG. 14, the spacer 10 is shown with the superior arm 14 seating the superior spinous process 138 of a first vertebral body 142 and the inferior arm 16 seating the inferior spinous process 140 of an adjacent second vertebral body 144 providing sufficient distraction to open the neural foramen 146 to relieve pain. As mentioned above, the shape of the superior arm 14 is such that a superior concavity or curvature 45 is provided to conform to the widening of the superior spinous process 138 in an anterior direction of the patient toward the superior lamina 148

going in the anterior direction. In general, the superior arm 14 is shaped to conform to anatomy in the location in which it is seated. Likewise, as mentioned above, the shape of the inferior arm 16 is such that an inferior convexity or curvature 47 is provided to conform to the widening of the inferior spinous process 140 in an anterior direction toward the inferior lamina 150. The supraspinous ligament 152 is also shown in FIG. 14. In FIG. 14, the lateral direction is into and out of the page and the superior 14 and inferior arms 14, 16 are configured to laterally stabilize the spacer 10 with respect to the adjacent spinous processes 138, 140.

[0110] The spacer 10 is as easily and quickly removed from body of the patient as it is installed. The instrument 80 is inserted into an incision and reconnected to the spacer 10. The shaft 50 is rotated in the opposite direction via a driver 104 to fold the arms 14, 16 into a closed or undeployed configuration. In the undeployed configuration, the spacer 10 can be removed from the patient along with the instrument 80 or, of course, re-adjusted and re-positioned and then re-deployed as needed with the benefit of minimal invasiveness to the patient.

[0111] Any of the spacers disclosed herein are configured for implantation employing minimally invasive techniques including through a small percutaneous incision and through the supraspinous ligament. Implantation through the supraspinous ligament involves selective dissection of the supraspinous ligament in which the fibres of the ligament are separated or spread apart from each other in a manner to maintain as much of the ligament intact as possible. This approach avoids crosswise dissection or cutting of the ligament and thereby reduces the healing time and minimizes the amount of instability to the affected spinal segment. While this approach is ideally suited to be performed through a posterior or midline incision, the approach may also be performed through one or more incisions made laterally of the spine with or without affect to the supraspinous ligament. Of course, the spacer may also be implanted in a lateral approach that circumvents the supraspinous ligament altogether as well as in open or mini-open procedures.

[0112] All publications mentioned herein are incorporated herein by reference to disclose and describe the methods and/or materials in connection with which the publications are cited. The publications discussed herein are provided solely for their disclosure prior to the filing date of the present application. Nothing herein is to be construed as an admission that the present invention is not entitled to antedate such publication by virtue of prior invention. Further, the dates of publication provided may be different from the actual publication dates which may need to be independently confirmed.

[0113] The preceding merely illustrates the principles of the invention. It will be appreciated that those skilled in the art will be able to devise various arrangements which, although not explicitly described or shown herein, embody the principles of the invention and are included within its spirit and scope. Furthermore, all examples and conditional language recited herein are principally intended to aid the reader in understanding the principles of the invention and the concepts contributed by the inventors to furthering the art, and are to be construed as being without limitation to such specifically recited examples and conditions. Moreover, all statements herein reciting principles, aspects, and embodiments of the invention as well as specific examples thereof, are intended to encompass both structural and functional equivalents thereof. Additionally, it is intended that such equivalents include both currently known equivalents and equivalents developed in the future, i.e., any elements developed that perform the same function, regardless of structure. The scope of the present invention, therefore, is not intended to be limited to the exemplary embodiments shown and described herein. Rather, the scope and spirit of present invention is embodied by the appended claims.

CLAIMS

1. An implant for placement between adjacent spinous processes in a spinal motion segment, the implant comprising:

a body defining a longitudinal axis;

a first arm connected to the body and configured to laterally stabilize the body with respect to a first spinous process when in a deployed configuration, wherein the first arm includes a pair of first extensions configured to receive the first spinous process between the first extensions; and

a second arm connected to the body and configured to laterally stabilize the body with respect to a second spinous process when in a deployed configuration;

a first bridge connected between the first extensions to define a first spinous process receiving portion, wherein the first pair of extensions are substantially parallel to a sagittal plane of the implant and the first bridge is angled with respect to the sagittal plane of the implant; and

wherein the first and second arms are configured for placement between adjacent spinous processes in which at least one of the adjacent spinous processes has a projection in a coronal plane that is angled with respect to the sagittal plane.

2. An implant for placement between adjacent spinous processes in a spinal motion segment, the implant comprising:

a body defining a longitudinal axis;

a first arm connected to the body and configured to laterally stabilize the body with respect to a first spinous process when in a deployed configuration, wherein the first arm includes a pair of first extensions configured to receive the first spinous process between the first extensions; and

a second arm connected to the body and configured to laterally stabilize the body with respect to a second spinous process when in a deployed configuration, wherein the second arm includes a pair of second extensions configured to receive the second spinous process between the second extensions;

a first bridge connected between the first pair of extensions to define a first spinous process receiving portion;

a second bridge connected between the second pair of extensions to define a second spinous process receiving portion; and

wherein the first and second arms are configured for placement between the spinous processes in which at least one of the adjacent spinous processes has a projection in a

coronal plane that is angled with respect to a sagittal plane of the implant, wherein the pair of first extensions and the pair of second extensions are substantially parallel to the sagittal plane of the implant and the first and second bridges are angled with respect to the sagittal plane of the implant.

3. The implant of claim 2 wherein the first and second bridges are angled with respect to each other.

4. An implant for placement between adjacent spinous processes in a spinal motion segment, the implant comprising:

a body defining a longitudinal axis;

a first arm connected to the body and configured to laterally stabilize the body with respect to a first spinous process when in a deployed configuration, wherein the first arm includes a pair of first extensions at a first fixed spaced apart relationship relative to one another and configured to receive the first spinous process between the first extensions; and

a second arm connected to the body and configured to laterally stabilize the body with respect to a second spinous process when in a deployed configuration, wherein the second arm includes a pair of second extensions at a second fixed spaced apart relationship relative to one another and configured to receive the second spinous process between the second extensions;

wherein the first and second arms are configured for placement between adjacent spinous processes in which at least one of the adjacent spinous processes has a projection in a coronal plane that is angled with respect to a sagittal plane of the implant, wherein each of the first extensions is permanently angled with respect to the sagittal plane of the implant and each of the second extensions is permanently angled with respect to the sagittal plane of the implant.

5. An implant for placement between adjacent spinous processes in a spinal motion segment, the implant comprising:

a body defining a longitudinal axis;

a first arm connected to the body and configured to laterally stabilize the body with respect to a first spinous process when in a deployed configuration, wherein the first arm includes a pair of first extensions configured to receive the first spinous process between the first extensions; and

a second arm connected to the body and configured to laterally stabilize the body with respect to a second spinous process when in a deployed configuration, wherein the

second arm includes a pair of second extensions configured to receive the second spinous process between the second extensions;

a first bridge connected between the first pair of extensions to define a first spinous process receiving portion;

a second bridge connected between the second pair of extensions to define a second spinous process receiving portion; and

wherein the first and second arms are configured for placement between adjacent spinous processes and which at least one of the adjacent spinous processes has a projection in a coronal plane that is angled with respect to a sagittal plane of the implant, wherein the pair of first extensions is angled with respect to the sagittal plane of the implant and the pair of second extensions is angled with respect to the sagittal plane of the implant and the first and second bridges are perpendicular to their respective extensions to which they are connected.

6. The implant of claim 1, wherein the distance between the first pair of extensions is greater than the distance between the second pair of extensions, the first and second arms are configured for placement between adjacent spinous processes in which at least one of the adjacent spinous processes has a projection in a coronal plane that is angled with respect to the sagittal plane, and the first pair of extensions are substantially parallel and the second pair of extensions are substantially parallel.

7. The implant of claim 1, wherein one extension of the first pair and one extension of the second pair that are adjacent to each other on the same side of the implant are both shorter than the other of the extensions, and the first and second arms are configured for placement between adjacent spinous processes in which at least one of the adjacent spinous processes has a projection in a coronal plane that is angled with respect to the sagittal plane.

8. The implant of claim 7 wherein the first pair of extensions are configured to rotate relative to the body about a first axis of rotation that is substantially perpendicular to a sagittal plane defined by the body when the body is positioned between the first spinous process and the second spinous process, the second pair of extensions are configured to rotate relative to the body about a second axis of rotation that is substantially perpendicular to the sagittal plane.

9. The implant of claim 4, wherein one extension of the first pair and one extension of the second pair that are adjacent to each other on the same side of the implant are both shorter than the other of the extensions, wherein the first and second arms are angled with

respect to each other such that the shorter extensions are angled towards each other, and the first and second arms are configured for placement between adjacent spinous processes in which at least one of the adjacent spinous processes has a projection in a coronal plane that is angled with respect to the sagittal plane.

10. An implant for placement between a first spinous process and a second spinous process in a spinal motion segment, the implant comprising:

a body defining a sagittal plane;

a first arm rotatably coupled to the body and configured to rotate relative to the body about a first axis of rotation generally perpendicular to the sagittal plane such that the first arm moves from an undeployed configuration to a deployed configuration, the first arm is configured to laterally stabilize the body with respect to the first spinous process when in the deployed configuration, the first arm comprising a first pair of extensions at a first permanent generally parallel arrangement and configured to receive the first spinous process when the first arm moves from the undeployed configuration to the deployed configuration; and

a second arm rotatably coupled to the body and configured to rotate relative to the body about a second axis of rotation generally perpendicular to the sagittal plane such that the second arm moves from an undeployed configuration to a deployed configuration, the second arm is configured to laterally stabilize the body with respect to the second spinous process when in the deployed configuration;

wherein the first and second arms are configured for placement between the first and second spinous processes in which the first pair of extensions are oriented at a permanent non-parallel angle with respect to the sagittal plane in the deployed configuration.

11. The implant of claim 10 further comprising a first bridge connected between the first pair of extensions to define a first spinous process receiving portion.

12. The implant of claim 11 wherein the first bridge is angled with respect to the sagittal plane of the body.

13. The implant of claim 12 wherein the first bridge is substantially perpendicular to the first pair of extensions.

14. The implant of claim 10 wherein the second arm includes a second pair of extensions configured to receive the second spinous process between the second extensions.

15. The implant of claim 14 further including a first bridge connected between the first pair of extensions to define a first spinous process receiving portion and a second bridge connected between the second pair of extensions to define a second spinous process receiving portion.

16. The implant of claim 15 wherein the first and second bridges are angled with respect to each other.

17. The implant of claim 14 wherein the first pair of extensions is oriented at an acute angle with respect to the sagittal plane of the body and the second pair of extensions is oriented at an acute angle with respect to the sagittal plane of the body in the deployed configuration.

18. The implant of claim 15 wherein the first pair of extensions is oriented at an acute angle with respect to the sagittal plane of the body and the second pair of extensions is oriented at an acute angle with respect to the sagittal plane of the body in the deployed configuration and the first and second bridges are perpendicular to their respective extensions to which they are connected.

19. The implant of claim 10 wherein:

the second arm comprises a pair of generally parallel extensions configured to receive the second spinous process; and

the second extensions are oriented at a non-parallel angle with reference to the sagittal plane in the deployed configuration.

20. The implant of claim 10, further comprising a first bridge extending between the first extensions, the first bridge defines a first angle in a range of 5 degrees to 75 degrees, the first angle is defined by the bridge and the first axis.

21. The implant of claim 10, further comprising a second bridge extending between the second extensions, the second bridge defines a second angle in a range of 5 degrees to 75 degrees, the second angle is defined by the second bridge and the second axis.

22. The implant of claim 10 wherein the first pair of extensions of the first arm are spaced apart to hold the first spinous process, wherein the second arm includes a second pair of extensions that are spaced apart to hold the second spinous process.

23. An implant for placement between adjacent vertebrae in a spinal motion segment, the implant comprising:

a body defining a sagittal plane;

a first arm connected to the body, the first arm having a first pair of substantially parallel extensions defining a first spinous process receiving portion for seating a superior spinous process therein when the first arm rotates relative to the body about a first axis that is substantially perpendicular to the sagittal plane; and

a second arm connected to the body, the second arm having a second pair of substantially parallel extensions defining a second spinous process receiving portion for seating an inferior spinous process therein when the second arm rotates relative to the body about a second axis that is substantially perpendicular to the sagittal plane;

wherein a distance between the first pair of extensions is greater than a distance between the second pair of extensions; and

wherein when the first and second spinous process receiving portions seat the corresponding superior and inferior spinous process, each of the first and second pairs of extensions is oriented at an acute angle with respect to the sagittal plane.

24. The implant of claim 23 wherein the first pair of extensions is angled with respect to the second pair of extensions.

25. The implant of claim 23 wherein:

the body further defines a longitudinal axis; and

the first and second arms are movable from an undeployed configuration in which the first and second arms are generally aligned with the longitudinal axis to a deployed configuration in which the first and second arms extend laterally away from the body at an angle generally perpendicular to the longitudinal axis.

26. An implant for placement between adjacent spinous processes in a spinal motion segment, the implant comprising:

a body defining a longitudinal axis;

a first arm connected to the body, the first arm having a first pair of extensions defining a spinous process receiving portion, wherein the first pair of extensions move superiorly and posteriorly as the first arm rotates relative to the body to seat a superior spinous process in the spinous process receiving portion when the longitudinal axis extends in an anterior-posterior direction; and

a second arm connected to the body, the second arm having a second pair of

extensions defining a spinous process receiving portion, wherein the second pair of extensions move inferiorly and posteriorly as the second arm rotates relative to the body to seat an inferior spinous process in the spinous process receiving portion defined by the second pair of extensions;

wherein one extension of the first pair and one extension of the second pair that are adjacent to each other are both shorter than the other of the extensions; and

wherein the first and second arms are movable from an undeployed configuration in which the first and second arms are generally aligned with the longitudinal axis to a deployed configuration in which the first and second arms extend laterally away from the body at an angle generally perpendicular to the longitudinal axis.

27. The implant of claim 26 further including a first bridge between the first pair of extensions and second bridge between the second pair of extensions.

28. The implant of claim 27 wherein the first and second bridge are angled with respect to each other.

29. The implant of claim 26 wherein the first and second arms are angled with respect to each other such that the shorter extensions are angled towards each other when the first and second arms are in the deployed configuration.

30. The implant of claim 29 wherein the first pair of extensions are parallel to one another and the second pair of extensions are parallel to one another.

31. The implant of claim 26 wherein:

the body further defines a sagittal plane;

the first pair of extensions are generally parallel to one another and the second pair of extensions are generally parallel to one another; and

wherein when the spinous process receiving portions seat the corresponding superior and inferior spinous process, each of the first and second pairs of extensions is oriented at a non-parallel angle with respect to the sagittal plane.

32. The implant of claim 26 wherein the first pair of extensions are spaced apart from one another to define a first opening, the first arm is pivotably coupled to the body such that the first pair of extensions concurrently move along opposite sides of the superior spinous

process when the first arm moves from the undeployed configuration to the deployed configuration.

33. The implant of claim 26 wherein the second pair of extensions are spaced apart from one another to define a second opening, the second arm is pivotably coupled to the body such that the second pair of extensions concurrently move along opposite sides of the inferior spinous process when the second arm moves from the undeployed configuration to the deployed configuration.

34. An implant for placement between adjacent spinous processes in a spinal motion segment, said implant being substantially as herein described with reference to any one of the embodiments of the invention illustrated in the accompanying drawings and/or examples.

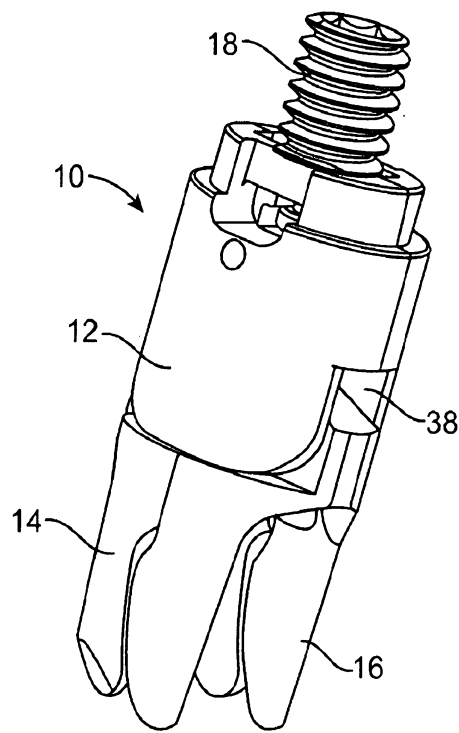

FIG. 1a

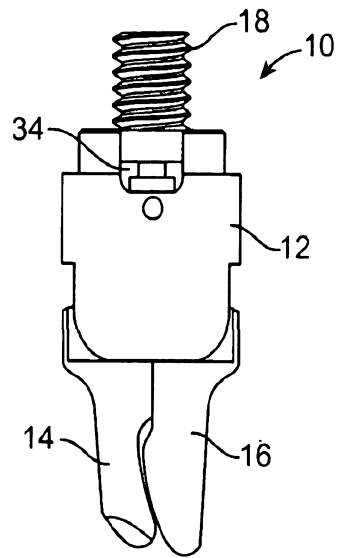

FIG. 1b

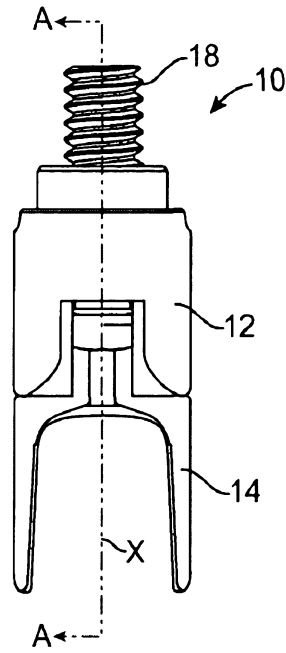
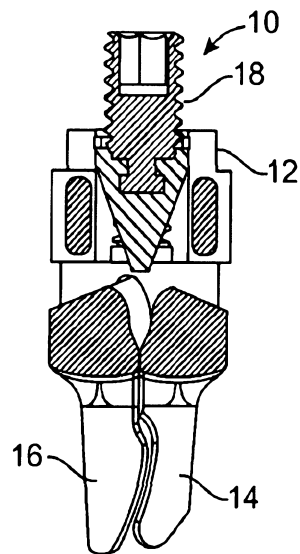

FIG. 1c



SECTION A-A

FIG. 1d

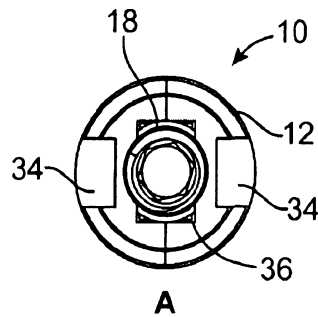

FIG. 1e

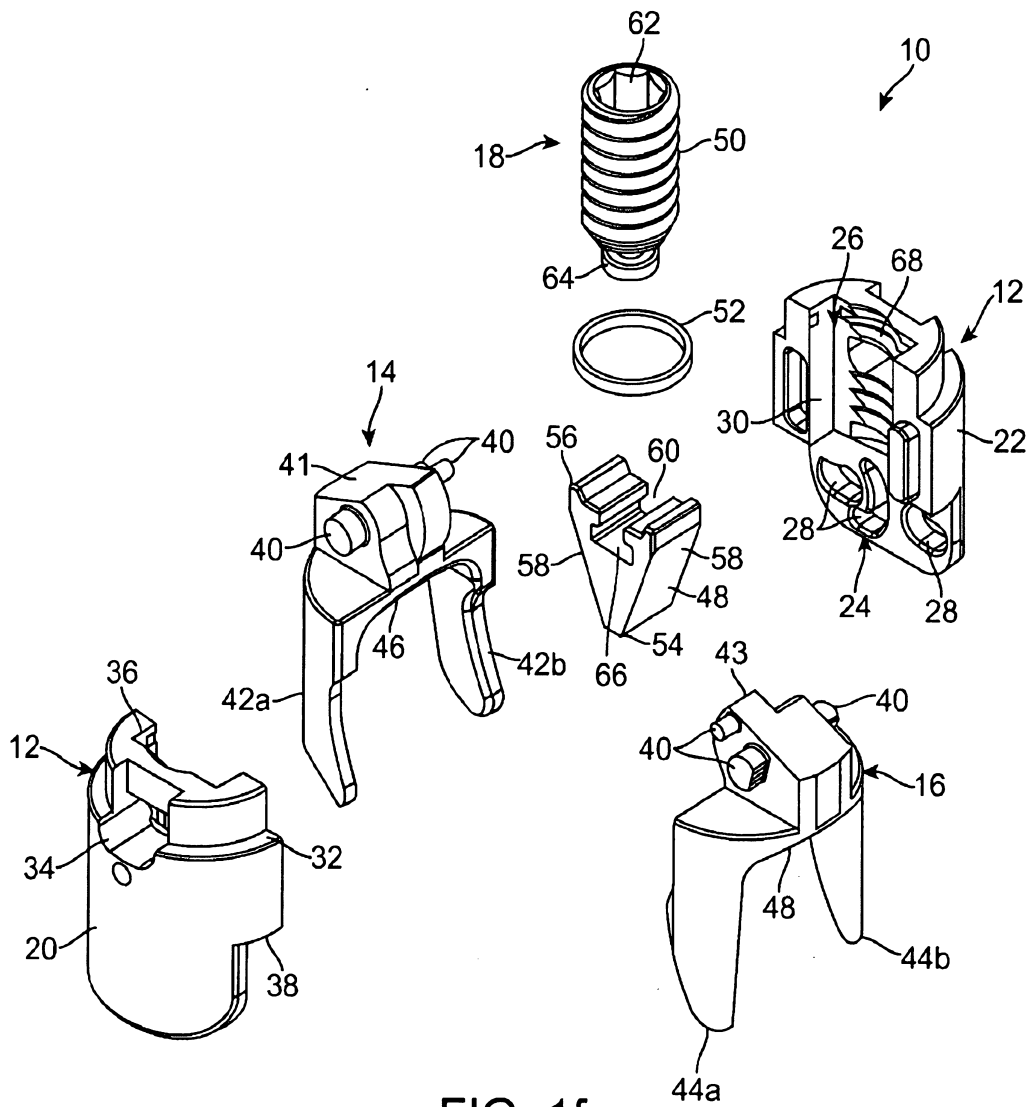

FIG. 1f

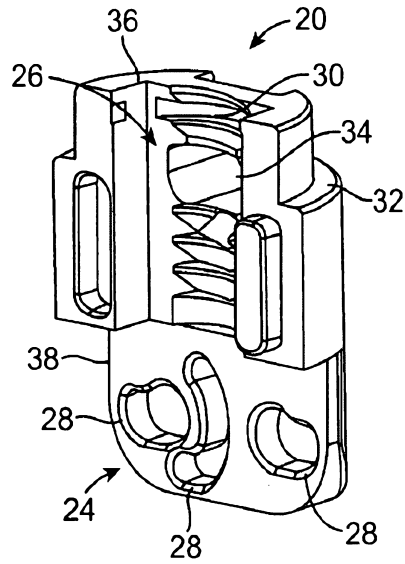

FIG. 2a

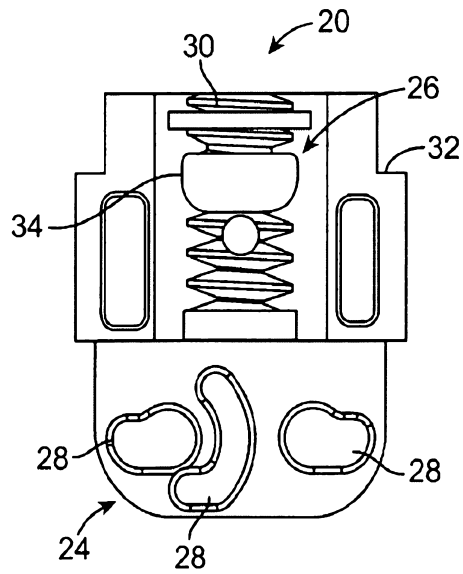

FIG. 2b

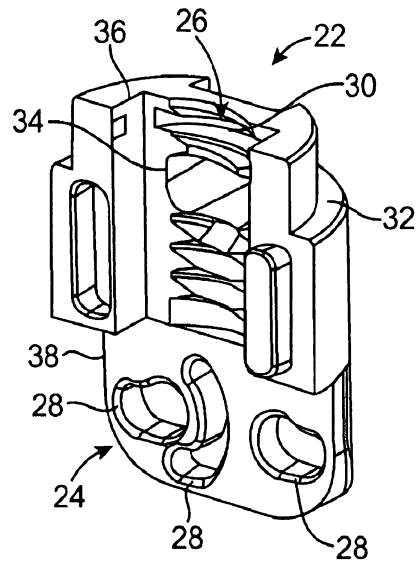

FIG. 2c

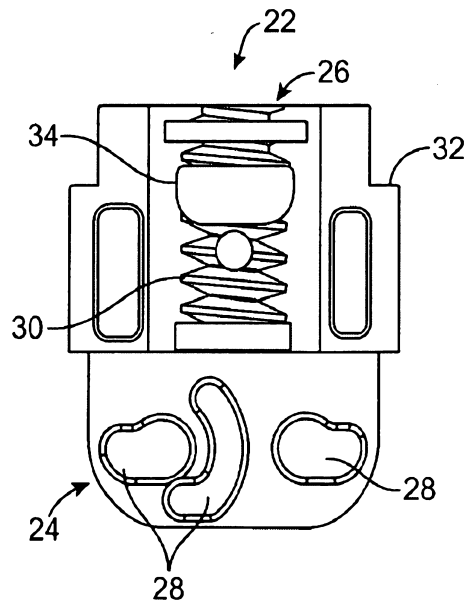

FIG. 2d

6/15

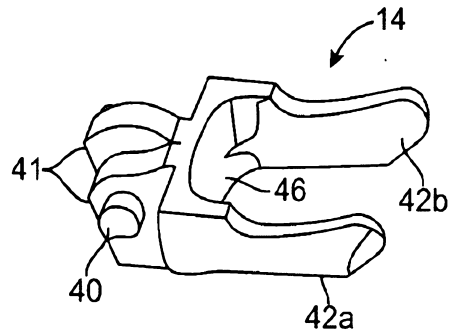

FIG. 3a

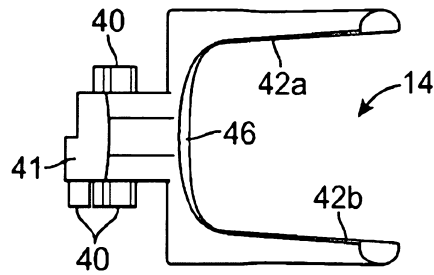

FIG. 3b

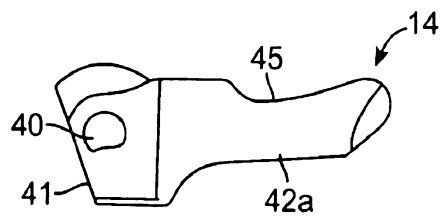

FIG. 3c

7/15

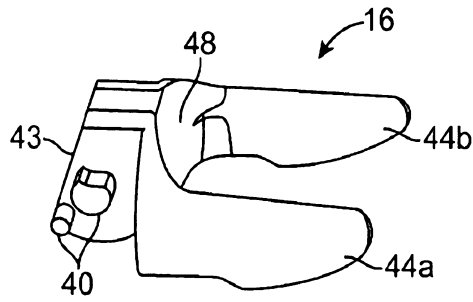

FIG. 3d

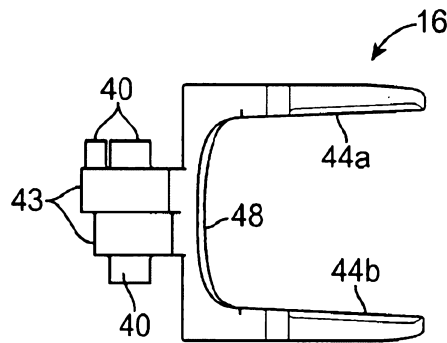

FIG. 3e

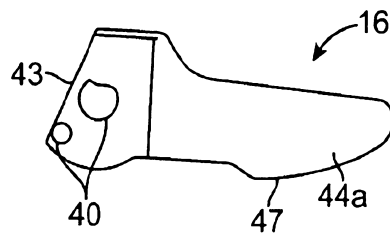

FIG. 3f

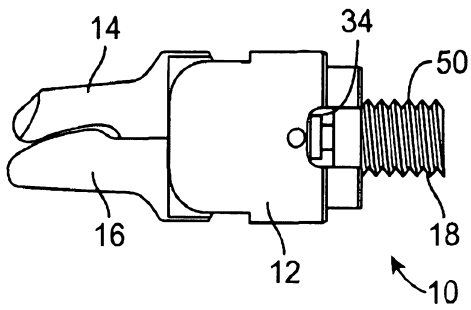

FIG. 4a

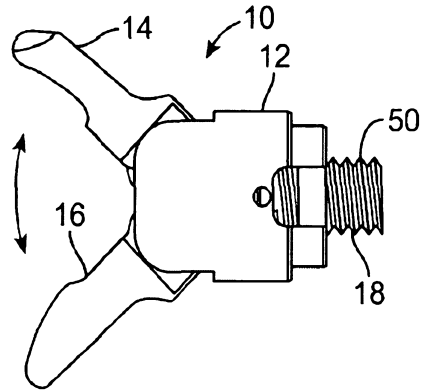

FIG. 4b

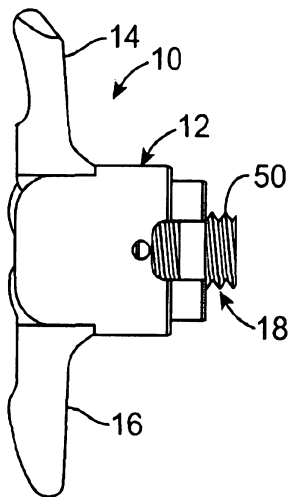

FIG. 4c

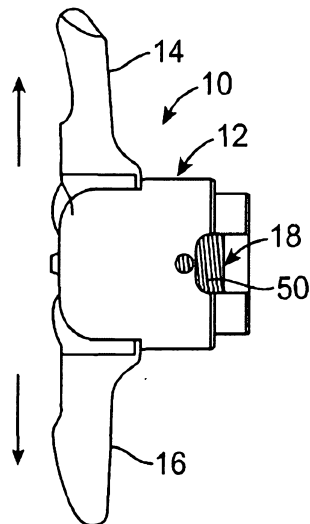

FIG. 4d

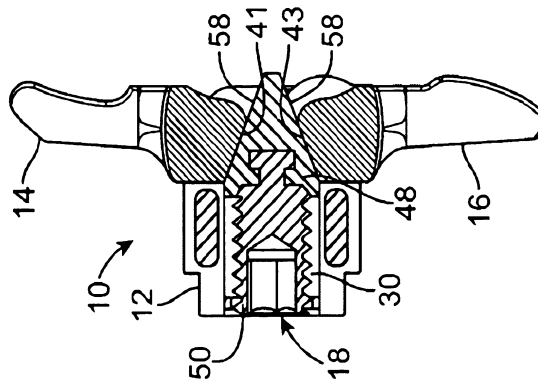

FIG. 5c

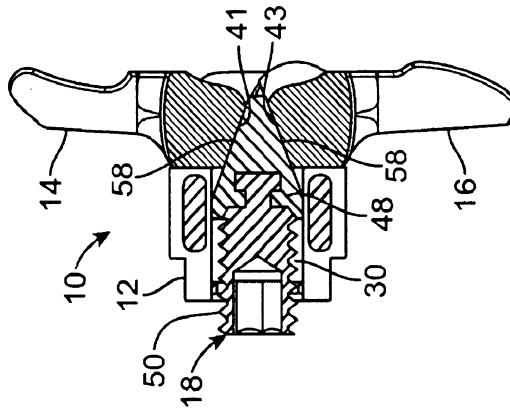

FIG. 5b

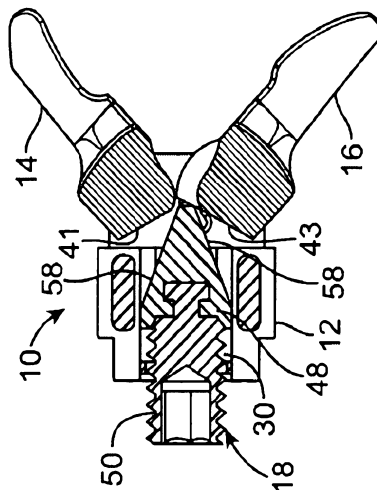

FIG. 5a

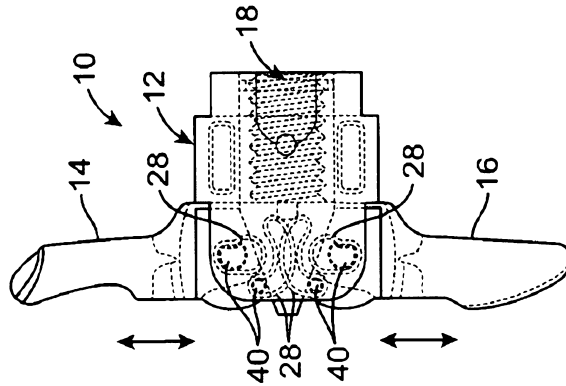

FIG. 6c

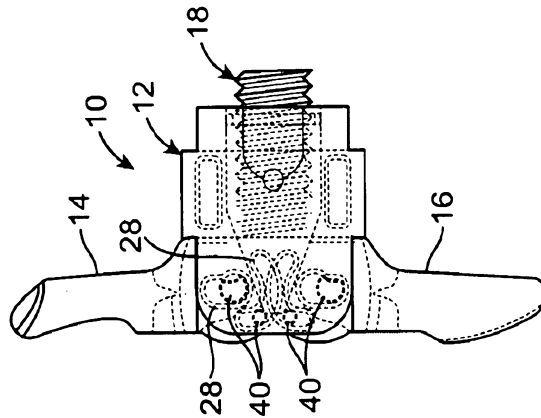

FIG. 6b

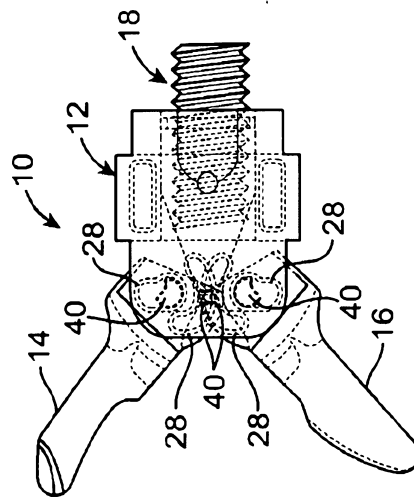

FIG. 6a

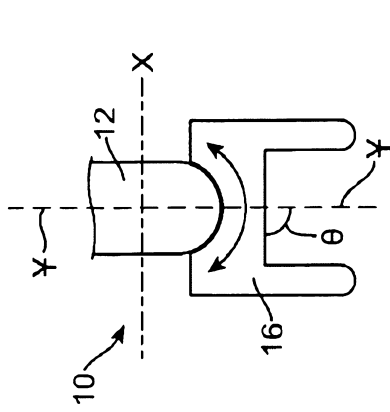

FIG. 10

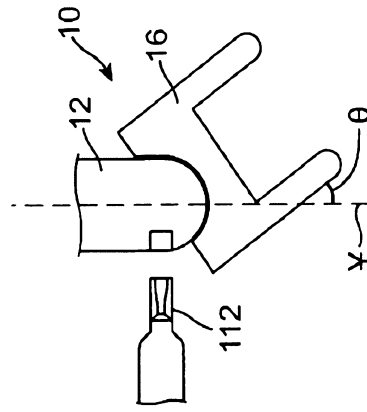

FIG. 11

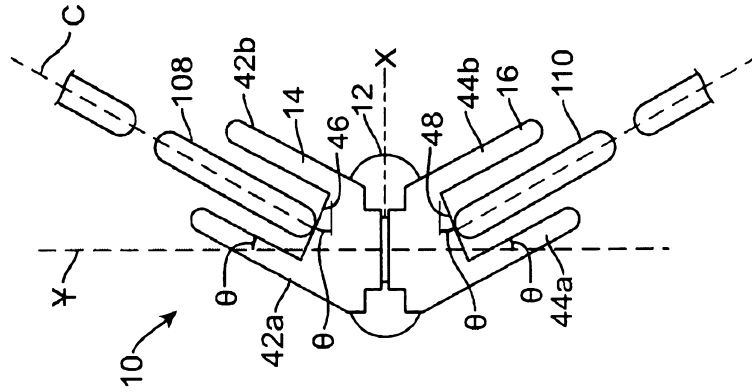

FIG. 9

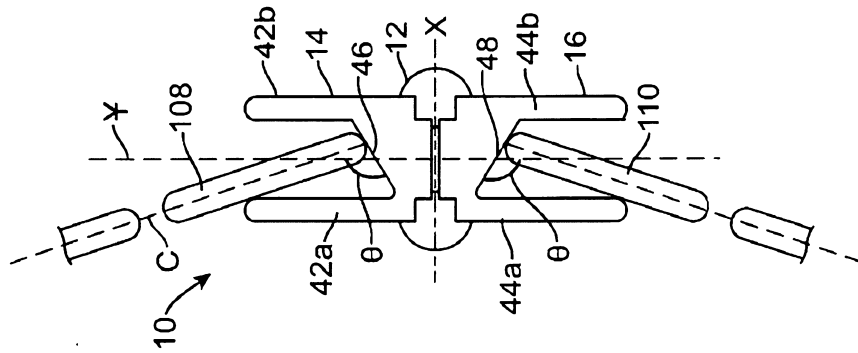

FIG. 8

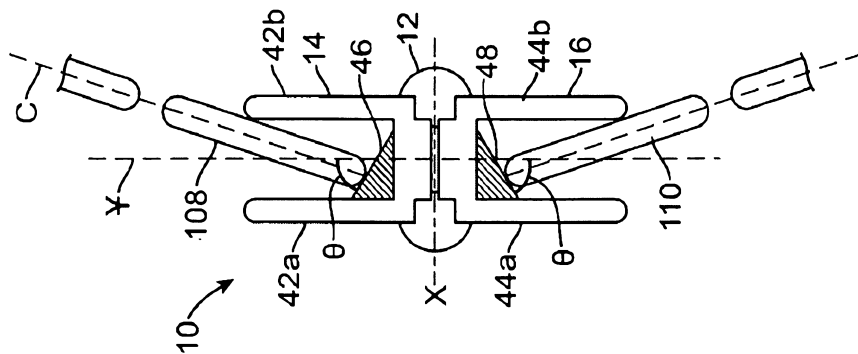

FIG. 7

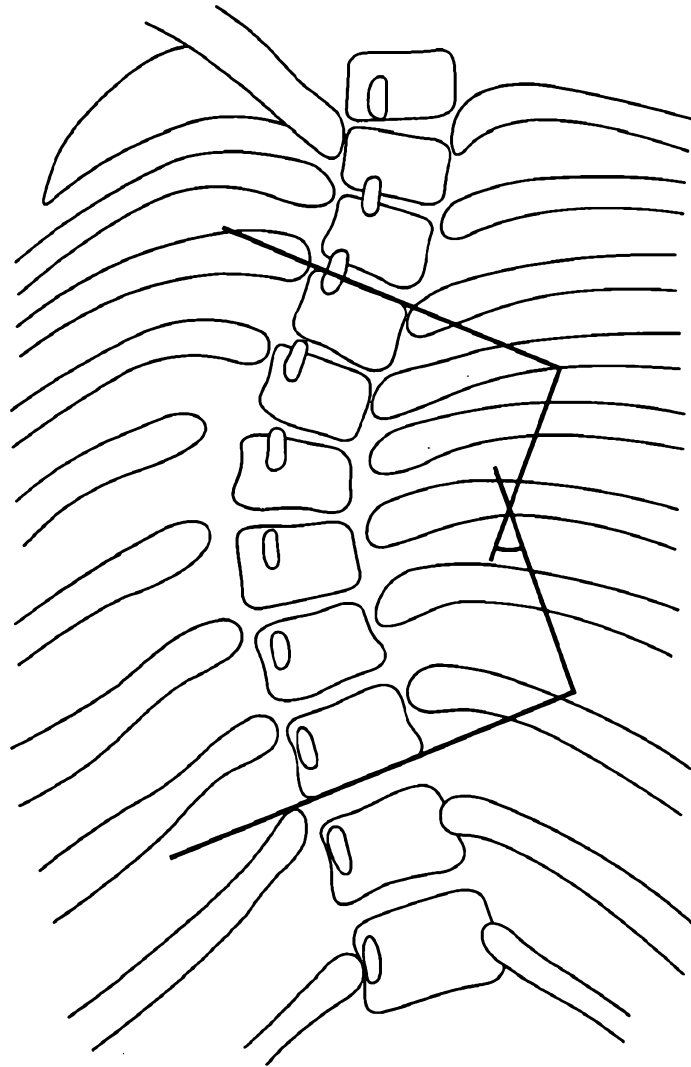

FIG. 12

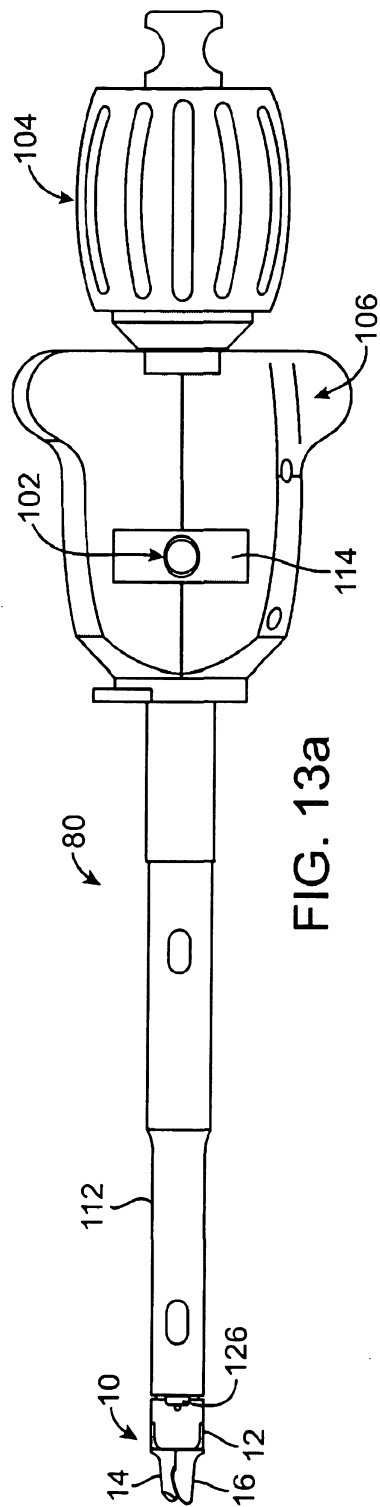

FIG. 13a

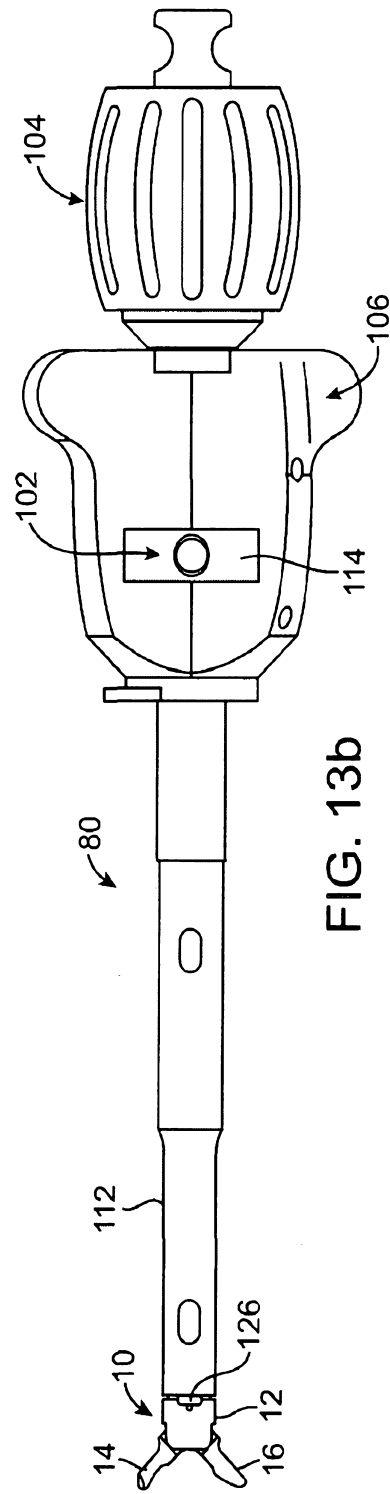

FIG. 13b

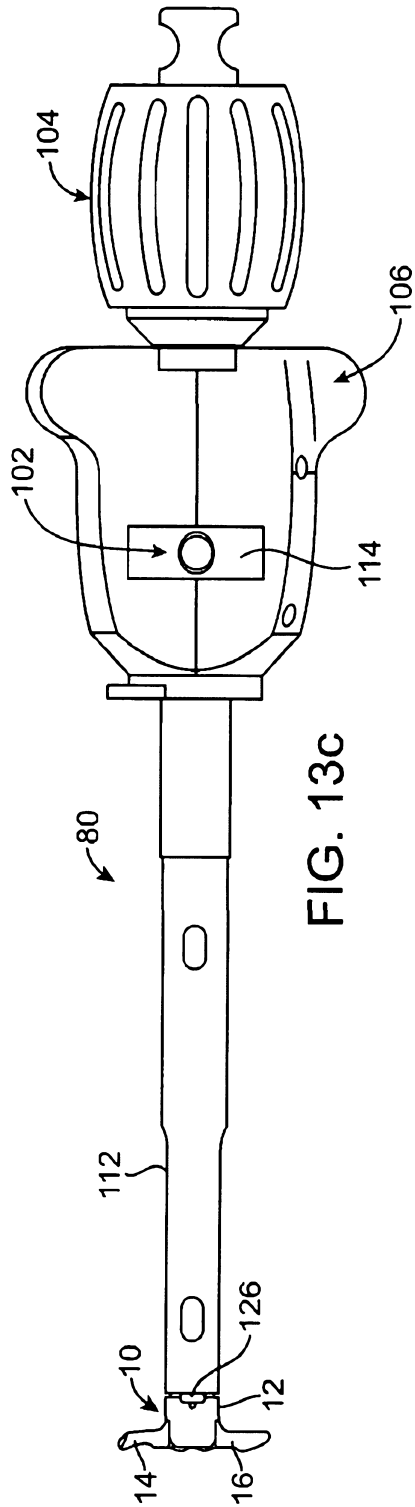

FIG. 13c

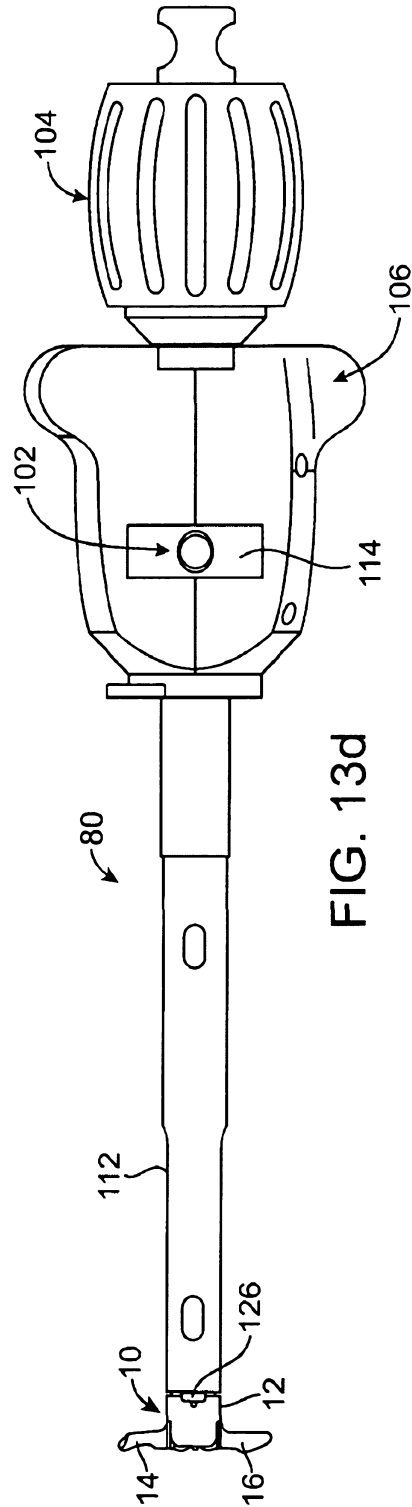

FIG. 13d

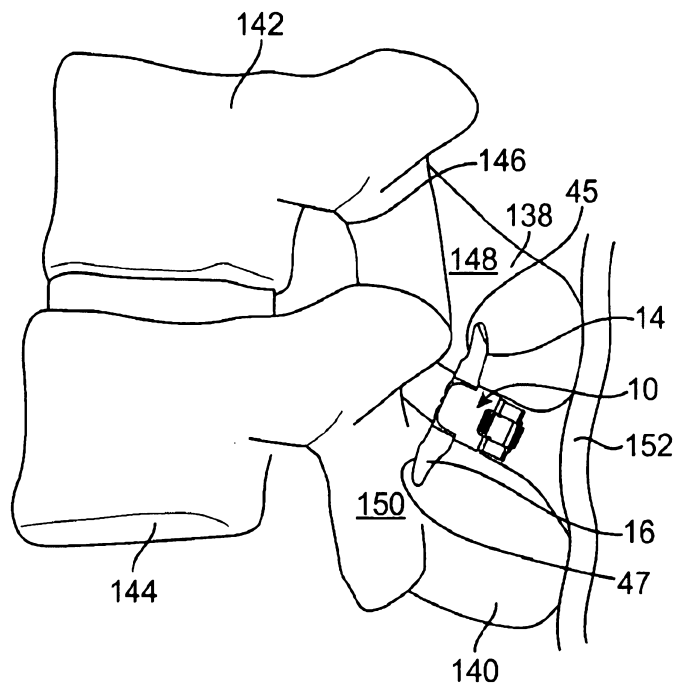

FIG. 14