

H. PARKER.
WINDOW SHADE.

No. 522,383.

Patented July 3, 1894.

Fig. 1.

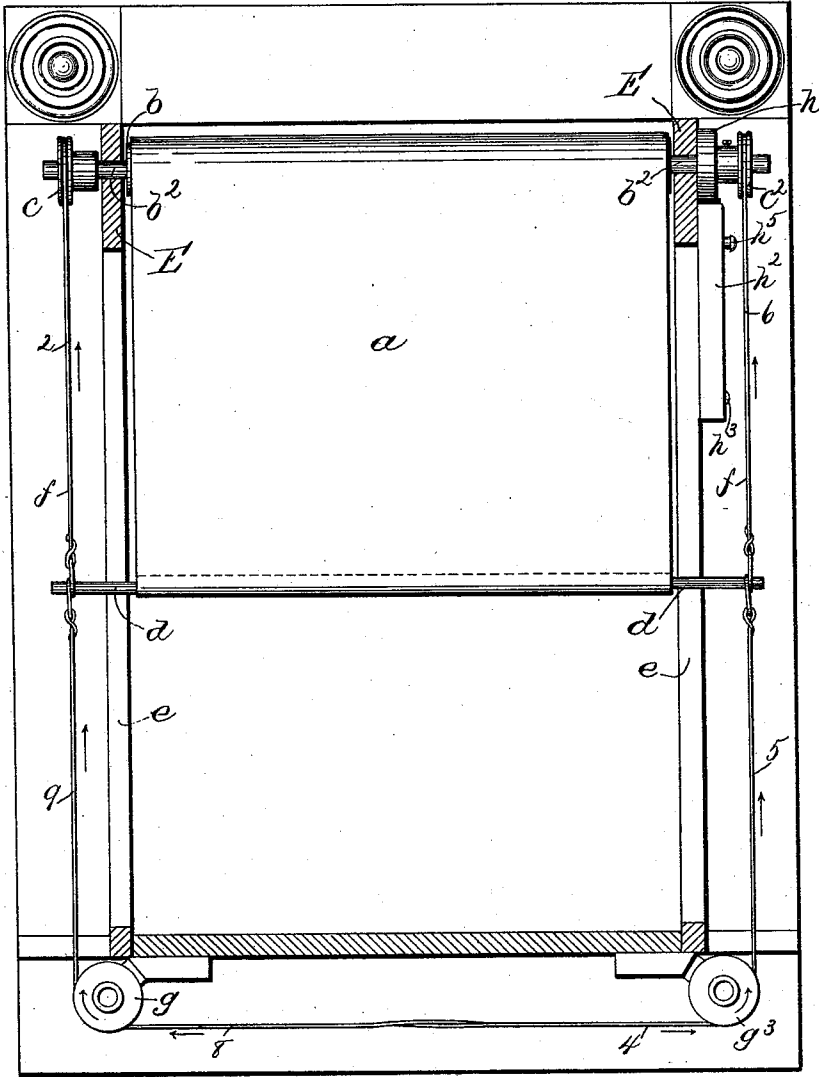

Fig. 2.

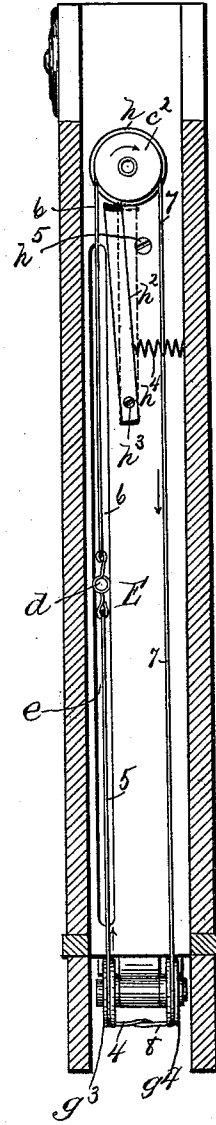
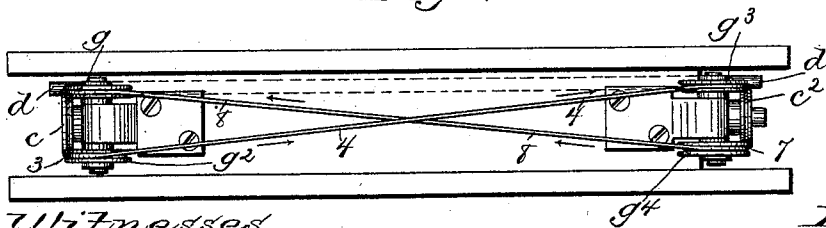

Fig. 3.



Witnesses
Jas. J. McAloney.
M. C. Kee.

Inventor.
Howard Parker.
by J. P. Swannell
Att'y.

H. PARKER.
WINDOW SHADE.

No. 522,383.

Patented July 3, 1894.

Fig. 4.

Fig. 5.

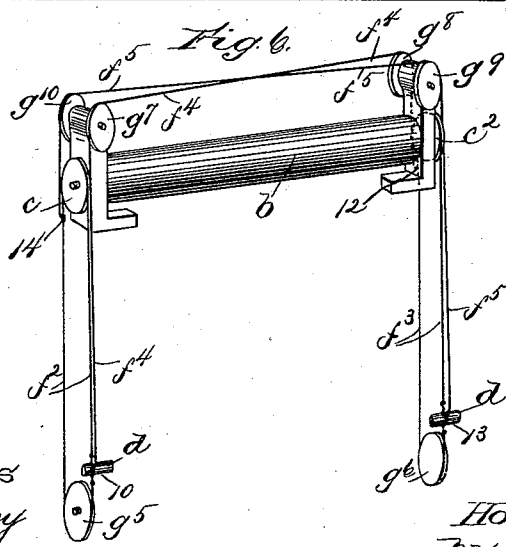
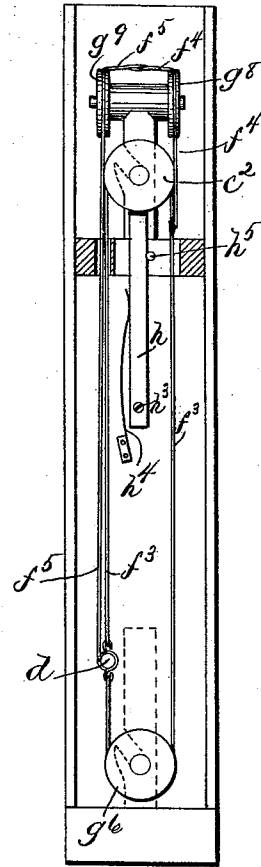
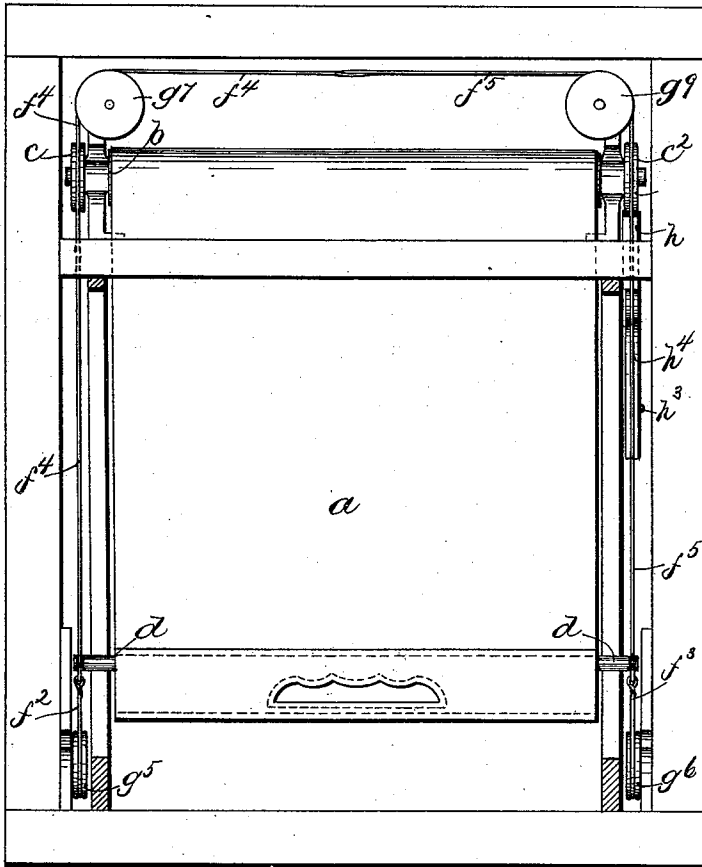

Witnesses
Jas. J. Kealoney
W. C. Rice

Inventor.
Howard Parker.
by *J. P. Swann*
Atty.

UNITED STATES PATENT OFFICE.

HOWARD PARKER, OF ST. JOHNSBURY, VERMONT.

WINDOW-SHADE.

SPECIFICATION forming part of Letters Patent No. 522,383, dated July 3, 1894.

Application filed November 20, 1893. Serial No. 491,484. (No model.)

To all whom it may concern:

Be it known that I, HOWARD PARKER, of St. Johnsbury, county of Caledonia, State of Vermont, have invented an Improvement in Window-Shades, of which the following description, in connection with the accompanying drawings, is a specification, like letters on the drawings representing like parts.

My invention relates to a window shade and is shown embodied in a shade especially adapted for use in car windows although it is obvious that it is applicable to other uses.

The invention consists mainly in the combination of the shade and shade roller upon which it is wound, with actuating connections between the lower end of the shade and the shade roller by which upward movement or pressure applied to the lower end of the shade is transmitted equally to both ends thereof and to the shade roller, which is thus rotated to wind the shade upon it by the movement of the lower end of the shade toward the roller. A friction or retarding device is applied to the roller to resist the rotation in the direction to unwind the shade so that the shade is unwound or lowered only by the direct pull of the shade itself upon the roller and is thus always maintained in a tense even condition.

The words "upper" and "lower" are used with reference to the usual position of the shade in the window frame with the roller at the top but it is obvious that the shade may be arranged to work properly in any position, unwinding vertically upward or downward, or horizontally if desired.

Figure 1 is a front elevation of a window shade and operating mechanism therefore embodying this invention, the front portion of the window casing being removed to show the working parts; Fig. 2 an end elevation thereof, a portion of the window casing being shown in section; Fig. 3 an underneath plan; Fig. 4 a front elevation showing a modified construction; Fig. 5 an end elevation thereof, and Fig. 6 a diagram showing in perspective the arrangement of the cords and pulleys of the construction shown in Figs. 4 and 5.

The construction shown in Figs. 1, 2 and 3 is preferably adopted when the mechanism is to be applied to the window frame and there

is sufficient room at the sides of and below the casing for the working parts.

The shade *a* may be connected in the usual manner with a roller *b* the journals *b*² of which work in suitable bearings near the upper parts of the sides of the window frame and extend into the casings where the ends of the roller shaft or journals have fixed upon them pulleys *c*, *c*², by which the shaft and roller are rotated to wind the shade as will be explained.

The lower end of the shade *a* is provided with a rod or stick *d* the ends of which extend through slots *e* in the sides *E* of the window frame in which slots the said stick can run up and down as the shade is raised or lowered. The upward movement of the stick *d* is caused by suitable connections to rotate the shaft of the roller *b* in the direction to wind the shade thereon, so that by merely raising the stick at the lower end of the shade the portion of the shade above is also raised and wound upon the roller. This result is accomplished by means of a cord or hand *f* attached to the ends of the stick *d* so as to accompany the same in its up and down movement and extending over the roller actuating pulleys *c*, *c*², so as to rotate the same and over intermediate guide pulleys *g*, *g*², *g*³, *g*⁴, the connections being such that an upward motion on either end of the stick *d* is transmitted through the cord to the other end of the said stick so as to give an upward pull upon the same, and said cord also acts upon both winding pulleys *c*, *c*², with the tendency to rotate them in the direction to wind the shade *a* on the roller.

In order to more clearly understand the operation the position of the cord may be traced as follows, beginning with the left hand of the stick *d* shown in Fig. 1, and the movement of the different parts of the cord derived from the upward movement of the stick being indicated by arrows on the several figures: From the point of attachment of the cord to the left hand end of the stick *d* the said cord extends upward as shown at 2, to the front of the pulley *c* thence over the said pulley and downward from the rear side thereof as shown at 3, Fig. 3, to guide the pulley *g*², see Fig. 3, at the rear left hand side of the window frame

and thence diagonally across as shown at 4, Figs. 1 and 3, to the guide pulley g^3 at the front right hand lower corner of the window frame and thence upward as shown at 5, Figs. 1 and 2 to the point of attachment with the right hand end of the stick d from which the cord continues upward as shown at 6 to the front of the pulley c^2 at the right hand end of the shade roller shaft and around the upper part of said pulley and down at the rear thereof as shown at 7, Fig. 2 to the pulley g^4 at the rear right hand lower corner of the window frame and thence diagonally across as shown at 8 Figs. 1 and 3, to the pulley g at the front left hand corner and thence upward as shown at 9, to the point of attachment with the left hand end of the stick d . By this connection of the cord with both ends of the stick upward pressure on any part of the stick is equalized throughout the same, so that if the operator lifts either end of the stick the other end will be carried up equally and the roller will be rotated to wind the shade thereon.

The roller together with the layers of the shade wound upon it is a little larger in diameter than the pulleys c , c^2 , so that the action of the cord on the latter will be sufficient to take up the shade by winding on the roller a little faster than it is supplied to the roller by the lifting of the stick d and consequently any slack that may at any time exist or be formed between the roller and the stick would be taken up when the shade was next raised.

In order to prevent the shade from running down by its own weight or from being unwound off the roll by the action of the cord on the pulleys when the stick is moved down faster than enough to supply the pull of the stick, a friction device or brake is provided to frictionally resist the rotation of the shade roller in the direction to unwind the shade without, however, resisting its rotation in the opposite direction. The said friction device is shown in this instance as comprising a friction wheel h see Fig. 1, fastened upon the roller shaft and a friction dog h^2 pivoted at h^3 to the side of the window casing and acted upon by a light spring h^4 see Fig. 2, tending to move the dog h into line between the pivot h^3 and the axis of the roller as shown in dotted lines Fig. 2. The upper end of the dog h^2 bears against the periphery of the friction wheel h and when the latter is rotated with the roller shaft in the direction that causes the shade to be wound upon the roller the friction of the wheel h on the upper end of the dog h^2 tends to swing the said dog on its pivot h^3 to the position shown in full lines Fig. 2, and thus to relieve the pressure of the end of the dog against the periphery of the roller so that no appreciable resistance is afforded to the rotation of the latter. When, however, the shaft is turned in the other direction as by the unwinding of the shaft, the slight friction between the end of the dog and the wheel h assisted by the spring h^4

tends to turn the dog to the position shown in dotted lines Fig. 2, in line between the pivot h^3 and the axis of the roll, so that said dog binds against the surface of the wheel and affords considerable resistance to its rotation in the direction to unwind the shade. The stop h^5 limits the movement of the dog in this direction and thus prevents it from being carried past the center of the roller and so as to relieve on the other side. The holding power of the dog on the wheel h should be greater than the frictional hold of the cord f on the pulleys c , c^2 , the result being that if for any reason the shade should become slack between the roller and the stick d the operator by pulling down upon the stick would first take up such slack, for although the downward movement of the stick would actuate the cord f in the proper direction to give the roller an unwinding movement, the roller would be held against thus unwinding by the dog h , and the cord f would have to slip on the pulley until finally the slack was wholly taken up, after which the unwinding pull applied to the shade itself by the operator would be sufficient to turn the roller and thus unwind more of the shade if it were desired to lower the same.

The construction shown in Figs. 4, 5, and 6 has substantially the same mode of operation as that already described but may be preferable in cases where there is not sufficient room below the sill for the guide pulleys g , g^2 , &c., or where it may not be desirable to cut through the sides E of the window casing, and the arrangement shown in Figs. 4, 5, and 6 may be mounted as shown upon a frame of its own which can be set inside of the usual window frame at the front of the window sash. The parts with the exception of the cords and guide pulleys are the same as in Figs. 1, 2, and 3 and are marked with the same reference letters. Instead of having a single cord extending continuously around the entire set of pulleys and attached to the end of the stick d as in the construction previously described, the winding pulleys c , c^2 , are connected with the ends of the stick d by two separate endless belts or cords f^2 , f^3 , each extending over the corresponding winding pulley and also over an idler or guide pulley g^5 at the left hand and g^6 at the right hand of the window frame. The ends of the stick d are connected with the portions of the said bands f^2 , f^3 , that extend from the front side of the pulleys c , c^2 , and in order to transmit the movement from one end of the stick to the other, or to afford a direct connection between the two ends of the stick the said bands f^2 , f^3 , are connected, together as follows, the parts being for convenience described in the position occupied when the shade is in its lowest position: The cord f^4 , is connected at 10 with the lower end of the front portion of the band f^2 and extends over a guide pulley g^7 above and at the front of the pulley c and thence diagonally across to a guide pulley g^8

above and at the rear of the right hand pulley c^2 and thence down and is connected at a point 12, with the upper end of the rear portion of the belt f^3 at the other side of the window frame. Similarly another cord f^5 connects at 13, with the lower end of the front portion of the band f^3 extends upward over the front, right hand guide pulley g^9 , and diagonally across to the left hand rear pulley g^{10} , and is connected at 14, with the upper end of the rear portion of the left hand band f^2 . Thus it will be seen that an upward movement or pressure applied for example at the left hand end of the stick d will act directly upon the belt f^2 connected with that end of the stick and actuate the said band so as to cause it to turn the pulley c in the direction to wind the shade thereon and at the same time the corresponding downward movement of the rear side of said band will be transmitted through the cord f^5 to the lower front end of the band f^3 connected with the opposite or right hand end of the stick d which will thus be pulled upward by the cords f^2 , and f^5 , in harmony with the upward movement of the left hand end of the stick, and similarly if the pressure were applied at the right hand end of the stick it would act directly through the band f^3 on the right hand winding pulley c^2 and it would also be transmitted through the cord f^4 to the left hand band f^2 and left hand end of the stick d . The unwinding movement of the roller is frictionally resisted by the dog h^2 as before described, but said dog is shown in Fig. 5, as co-operating with the periphery of the pulley c^2 instead of with a special friction wheel, provided for that purpose.

It is obvious that the mechanism shown in Figs. 4, 5, and 6, could be applied to the window frame itself instead of to a special frame inserted therein, in which case the pulleys g^7 , g^8 , g^9 , g^{10} , would be applied above the cap piece of the frame instead of below the sill as shown in Fig. 1. By the herein described connections between the shade, roller, and both ends of the stick connected with the lower or running end of the shade, the shade itself is readily manipulated as desired merely

by lifting up or pulling down upon any part of the stick according as the shade is to be raised or lowered and there is no possibility of one part being raised more readily than the other, so as to cause uneven hanging or unwinding of the shade which is thus always maintained in flat, tense condition, or is readily brought to that condition by moving the stick up and down if it should at any time be slackened by pulling on the shade at an intermediate point between the stick and roller.

I claim—

1. The combination of a window shade and winding roller therefor provided with actuating pulleys at each end with a cord or band extending around but not winding on each of said pulleys, each of said bands being connected with the adjacent side of the lower or running end of the shade and also with the opposite side thereof as set forth; whereby an upward movement of the lower part of the shade is transmitted equally to both said winding pulleys rotating the same in the direction to wind the shade thereon, substantially as described.

2. The combination of a window shade and winding roller therefor provided with actuating pulleys at each end, with a cord or band extending around but not winding on each of said pulleys, each of said bands being connected with the adjacent side of the lower or running end of the shade and also with the opposite side thereof as set forth; whereby an upward movement of the lower part of the shade is transmitted equally to both said winding pulleys rotating the same in the direction to wind the shade thereon, and a brake affording a yielding resistance to rotation of the roll in the direction to unwind the shade therefrom substantially as and for the purpose described.

In testimony whereof I have signed my name to this specification in the presence of two subscribing witnesses.

HOWARD PARKER.

Witnesses:

NELLIE M. PARKER,
ANDREW WYRE.