



(86) **Date de dépôt PCT/PCT Filing Date:** 2010/11/17
 (87) **Date publication PCT/PCT Publication Date:** 2011/05/26
 (45) **Date de délivrance/Issue Date:** 2018/02/13
 (85) **Entrée phase nationale/National Entry:** 2012/05/16
 (86) **N° demande PCT/PCT Application No.:** US 2010/057109
 (87) **N° publication PCT/PCT Publication No.:** 2011/063046
 (30) **Priorité/Priority:** 2009/11/19 (US12/621,683)

(51) **Cl.Int./Int.Cl. A61B 17/115** (2006.01),
A61B 17/11 (2006.01), **A61B 46/10** (2016.01),
A61B 46/13 (2016.01)

(72) **Inventeurs/Inventors:**
 BAXTER, CHESTER O., III, US;
 HUNT, JOHN V., US;
 SILKAITIS, DANIEL P., US;
 WILEY, JEFFREY P., US;
 FRANER, PAUL T., US;
 SCHULTE, JOHN B., US;
 ABBOTT, DANIEL J., US

(73) **Propriétaire/Owner:**
 ETHICON ENDO-SURGERY, INC., US

(74) **Agent:** NORTON ROSE FULBRIGHT CANADA

(54) **Titre : DISPOSITIF D'INTRODUCTION D'AGRAFEUSE CIRCULAIRE AVEC UNE PARTIE D'EXTREMITÉ DISTALE POUVANT ETRE OUVERTE RADIALEMENT**

(54) **Title: CIRCULAR STAPLER INTRODUCER WITH RADIALLY-OPENABLE DISTAL END PORTION**

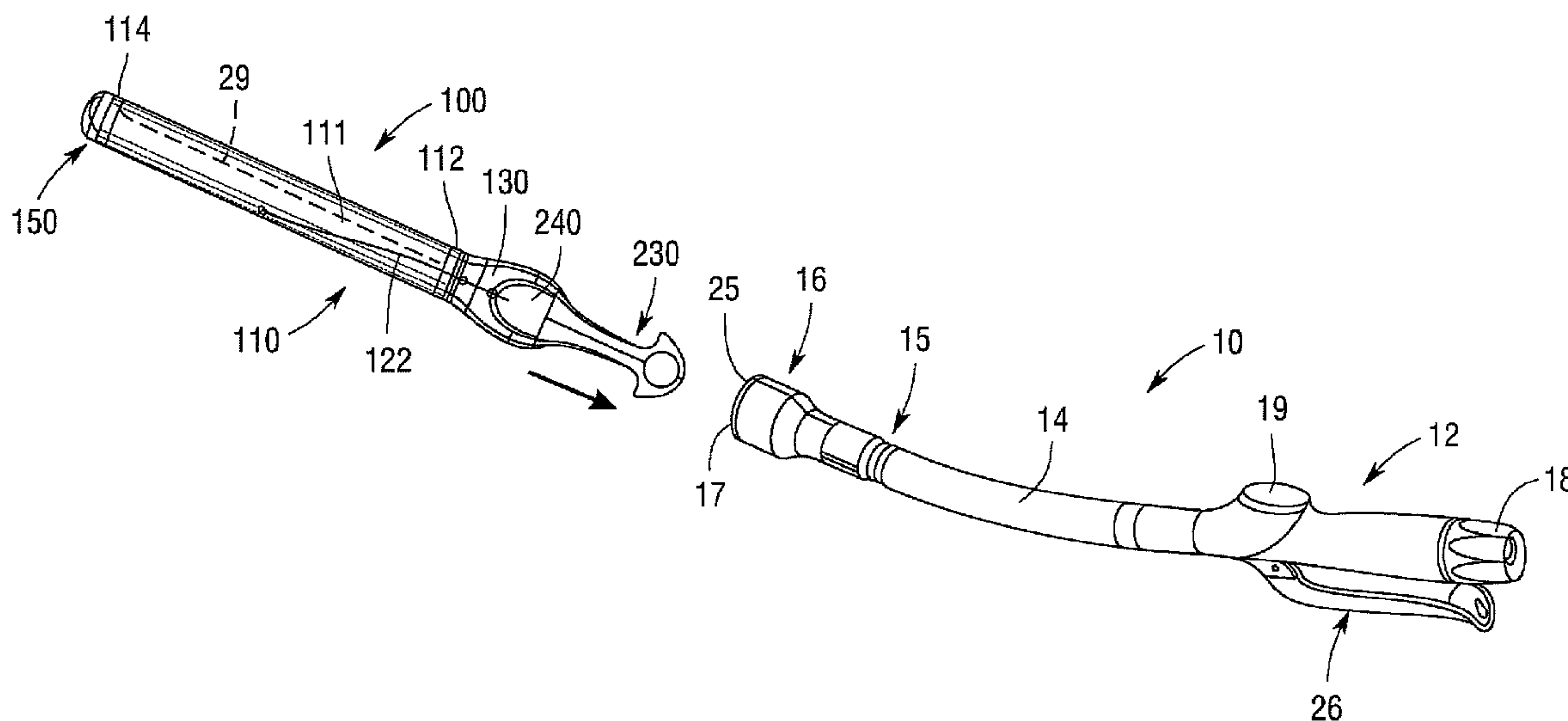

(57) **Abrégé/Abstract:**

Introducers for introducing a surgical circular stapler into a patient. Various embodiments comprise a hollow flexible sheath (110) that has a distal end (114) and an open proximal end (112) that is sized to receive a stapling head portion of the circular stapler therein. A radially - openable barrel member (152) is attached to a distal end of the hollow flexible sheath to define an opening for receiving the stapling head therein. A rigid cap member (160) is hingably attached to the radially-openable barrel member and is movable between a closed position wherein the rigid cap member covers a distal end of the opening in the barrel member and open position wherein the rigid cap member is movable to a position wherein the distal end of the opening is exposed. A releasable latch member (140) is provided to engage and release opposed ends of the radially-openable barrel member.

(74) **Agent(suite/continued):** LLP/S.E.N.C.R.L., S.R.L.

(12) INTERNATIONAL APPLICATION PUBLISHED UNDER THE PATENT COOPERATION TREATY (PCT)

(19) World Intellectual Property Organization
International Bureau(43) International Publication Date
26 May 2011 (26.05.2011)(10) International Publication Number
WO 2011/063046 A1

(51) International Patent Classification:

A61B 17/115 (2006.01) A61B 17/11 (2006.01)
A61B 17/00 (2006.01) A61B 19/00 (2006.01)

(21) International Application Number:

PCT/US2010/057109

(22) International Filing Date:

17 November 2010 (17.11.2010)

(25) Filing Language:

English

(26) Publication Language:

English

(30) Priority Data:

12/621,683 19 November 2009 (19.11.2009) US

(71) Applicant (for all designated States except US):
ETHICON ENDO-SURGERY, INC. [US/US]; 4545
Creek Road, Cincinnati, OH 45242 (US).

(72) Inventors; and

(75) Inventors/Applicants (for US only): **BAXTER, Chester, O., III** [US/US]; 6375 Pawnee Ridge, Loveland, OH 45140 (US). **HUNT, John, V.** [US/US]; 3654 Moorhill Drive, Cincinnati, OH 45241 (US). **SILKAITIS, Danius, P.** [US/US]; 4680 Sarah Drive, Mason, 45040 (US). **WILEY, Jeffrey, P.** [US/US]; 5585 Autumn Wynd Lane, Milford, 45150 (US). **FRANER, Paul, T.** [US/US]; 6217 Rapid Run Road, Cincinnati, OH 45233 (US). **SCHULTE, John, B.** [US/US]; 6769 Timberwood Drive, West Chester, OH 45069 (US). **ABBOTT, Daniel, J.** [US/US]; 5944 Marsh Circle, Loveland, OH 45140 (US).(74) Agents: **JOHNSON, Philip, S.** et al.; Johnson & Johnson, 1 Johnson & Johnson Plaza, New Brunswick, NJ 08933 (US).

(81) Designated States (unless otherwise indicated, for every kind of national protection available): AE, AG, AL, AM, AO, AT, AU, AZ, BA, BB, BG, BH, BR, BW, BY, BZ, CA, CH, CL, CN, CO, CR, CU, CZ, DE, DK, DM, DO, DZ, EC, EE, EG, ES, FI, GB, GD, GE, GH, GM, GT, HN, HR, HU, ID, IL, IN, IS, JP, KE, KG, KM, KN, KP, KR, KZ, LA, LC, LK, LR, LS, LT, LU, LY, MA, MD, ME, MG, MK, MN, MW, MX, MY, MZ, NA, NG, NI, NO, NZ, OM, PE, PG, PH, PL, PT, RO, RS, RU, SC, SD, SE, SG, SK, SL, SM, ST, SV, SY, TH, TJ, TM, TN, TR, TT, TZ, UA, UG, US, UZ, VC, VN, ZA, ZM, ZW.

(84) Designated States (unless otherwise indicated, for every kind of regional protection available): ARIPO (BW, GH, GM, KE, LR, LS, MW, MZ, NA, SD, SL, SZ, TZ, UG, ZM, ZW), Eurasian (AM, AZ, BY, KG, KZ, MD, RU, TJ, TM), European (AL, AT, BE, BG, CH, CY, CZ, DE, DK, EE, ES, FI, FR, GB, GR, HR, HU, IE, IS, IT, LT, LU, LV, MC, MK, MT, NL, NO, PL, PT, RO, RS, SE, SI, SK, SM, TR), OAPI (BF, BJ, CF, CG, CI, CM, GA, GN, GQ, GW, ML, MR, NE, SN, TD, TG).

Declarations under Rule 4.17:

- as to the identity of the inventor (Rule 4.17(i))
- as to applicant's entitlement to apply for and be granted a patent (Rule 4.17(ii))
- as to the applicant's entitlement to claim the priority of the earlier application (Rule 4.17(iii))

Published:

- with international search report (Art. 21(3))

(54) Title: CIRCULAR STAPLER INTRODUCER WITH RADIALLY-OPENABLE DISTAL END PORTION

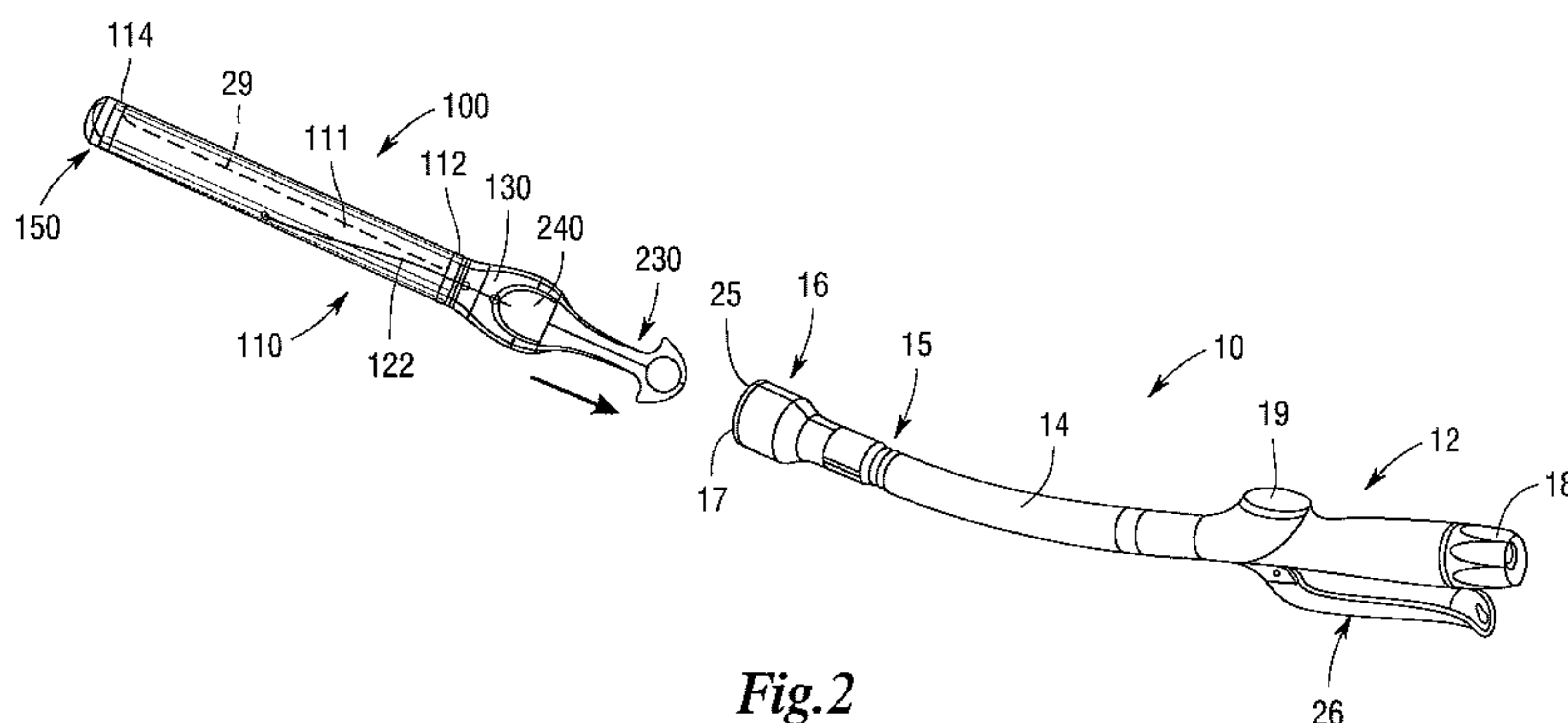

Fig. 2

(57) Abstract: Introducers for introducing a surgical circular stapler into a patient. Various embodiments comprise a hollow flexible sheath (110) that has a distal end (114) and an open proximal end (112) that is sized to receive a stapling head portion of the circular stapler therein. A radially - openable barrel member (152) is attached to a distal end of the hollow flexible sheath to define an opening for receiving the stapling head therein. A rigid cap member (160) is hingably attached to the radially-openable barrel member and is movable between a closed position wherein the rigid cap member covers a distal end of the opening in the barrel member and open position wherein the rigid cap member is movable to a position wherein the distal end of the opening is exposed. A releasable latch member (140) is provided to engage and release opposed ends of the radially-openable barrel member.



WO 2011/063046 A1

TITLE

CIRCULAR STAPLER INTRODUCER WITH
RADIALLY-OPENABLE DISTAL END PORTION

FIELD OF THE INVENTION

[0001] The present invention generally relates to surgical staplers, and more particularly, to devices and methods for introducing a circular stapling device into the colon of a patient.

BACKGROUND

[0002] In certain types of surgical procedures, the use of surgical staples has become the preferred method of joining tissue and, as such, specially configured surgical staplers have been developed for these applications. For example, intra-luminal or circular staplers have been developed for use in surgical procedures involving the lower colon wherein sections of the lower colon are joined together after a diseased portion has been excised. Circular staplers useful for performing such procedures are disclosed, for example, in U.S. Pat. Nos. 5,104,025; 5,205,459; 5,285,945; and 5,309,927.

[0003] In general, a conventional circular stapler typically consists of an elongated shaft that has a proximal actuating mechanism and a distal stapling mechanism mounted to the elongated shaft. The distal stapling mechanism commonly consists of a fixed stapling cartridge that contains a plurality of staples configured in a concentric circular array. A round cutting knife is concentrically mounted in the cartridge interior to the staples for axial travel therein. Extending axially from the center of the cartridge is a movable trocar shaft that is adapted to have a staple anvil removably coupled thereto. The anvil is configured to form the ends of the staples as they are driven into it. The distance between a distal face of the staple cartridge and the staple anvil is commonly controlled by an adjustment mechanism that is mounted to the proximal end of the stapler shaft for controlling the axial movement of the trocar. Tissue that is clamped between the staple cartridge and the staple anvil is simultaneously stapled and cut when the actuating mechanism is activated by the surgeon.

[0004] When performing a lower colon procedure using a circular stapler, the intestine is typically stapled using a conventional surgical stapler with double rows of staples being

emplaced on either side of the diseased portion of intestine to be removed. The target section is simultaneously cut as the adjoining end is stapled. After removing the diseased portion, the surgeon typically inserts the anvil into the proximal end of the lumen, proximal of the staple line. This is done by inserting the anvil head into an entry port cut into the proximal lumen by the surgeon. On occasion, the anvil can be placed transanally, by placing the anvil head on the distal end of the stapler and inserting the instrument through the rectum. The surgeon then ties the proximal end of the intestine to the anvil shaft using a suture or other conventional tying device. Next, the surgeon cuts excess tissue adjacent to the tie and the surgeon attaches the anvil to the trocar shaft of the stapler. The surgeon then closes the gap between the anvil and cartridge, thereby clamping the proximal and distal ends of the intestine in the gap. The surgeon next actuates the stapler causing several rows of staples to be driven through both ends of the intestine and formed, thereby joining the ends and forming a tubular pathway. Simultaneously, as the staples are driven and formed, the concentric circular knife blade is driven through the intestinal tissue ends, cutting the ends adjacent to the inner row of staples. The surgeon then withdraws the stapler from the intestine and the procedure is complete.

[0005] During such lower colon procedures, it may be difficult to insert the surgical stapler thru the anus and past the transverse folds in the rectal wall that protrude into the colon which are commonly referred to as the “Valves of Houston” and subsequently manipulated to the desired area. This problem is exacerbated when the stapler must be inserted without the anvil in position. In particular, the forward or distal end of most circular staplers comprises a relatively abrupt circular-shaped member designed to support a circular staple cartridge. Such blunt/abrupt shape makes it difficult to advance the forward end of the stapler past the Valves of Houston and other tissue.

[0006] Thus, the need exists for devices and methods for easily inserting a surgical stapler through a patient’s anus into the lower colon or into other areas within the patient.

[0007] The foregoing discussion is intended only to illustrate some of the shortcomings present in the field of the invention at the time, and should not be taken as a disavowal of claim scope.

BRIEF SUMMARY

[0008] In connection with a general aspect of the present invention, there is provided an introducer for introducing a surgical circular stapler that has a handle portion, an elongated shaft that protrudes from the handle portion, and a stapling head that is coupled to the elongated shaft into a patient. In connection with various embodiments, the introducer comprises a hollow flexible sheath that has a distal end and an open proximal end. The hollow flexible sheath may be sized to receive the stapling head and at least a portion of the elongated shaft therein. A radially-openable barrel member may be attached to a distal end of the hollow flexible sheath. The barrel member may define an opening for receiving the stapling head therein. A rigid cap member may be hingably attached to the radially-openable barrel member and may be movable between a closed position wherein the rigid cap member covers a distal end of the opening in the barrel member and an open position wherein the rigid cap member is movable to a position exposing the distal end of the opening. A latch member may be oriented in selective engagement with the opposed ends of the barrel member to retain the rigid cap member in the closed position and an unlatched position wherein the opposed ends may move radially away from each other to enable the rigid cap member to move to the open position.

[0009] In connection with another general aspect of the present invention, there is provided an introducer for introducing a surgical circular stapler that has a handle portion, an elongated shaft that protrudes from the handle portion, and a stapling head that is coupled to the elongated shaft into a patient. In connection with various embodiments, the introducer comprises a hollow flexible sheath that has a distal end and an open proximal end. The hollow flexible sheath may be sized to receive the stapling head and at least a portion of the elongated shaft therein. A radially-openable barrel member may be attached to a distal end of the hollow flexible sheath. The barrel member may define an opening for receiving the stapling head therein when the barrel member is in a latched position. A rigid cap member may be hingably attached to the barrel member. The rigid cap member may be movable between a closed position wherein the rigid cap member is retained in a closed position covering a distal face of the stapling head when the stapling head has been inserted to a fully inserted position therein and an open position exposing the distal face of the stapling head. A latch member may be provided to releasably retain opposed ends of the barrel member in the latched position. Upon application of a release motion to the latch member, the latch member

may urge the opposed ends of the barrel member away from each other to an unlatched position.

[0010] In connection with yet another general aspect of the present invention, there is provided a method for introducing a stapling head and elongated shaft of surgical circular stapler into a patient. The method may comprise inserting the stapling head and elongated shaft into an introducer comprising a hollow sheath that has a rigid distal cap assembly attached thereto. The method may further comprise inserting the stapling head and elongated shaft portion and the hollow sheath into the patient such that a portion of the introducer is accessible from outside of the patient and positioning the stapling head in a desired position within the patient. The method may further include withdrawing the introducer from the patient without withdrawing the stapling head out of the patient.

BRIEF DESCRIPTION OF THE FIGURES

[0011] The accompanying drawings, which are incorporated in and constitute a part of this specification, illustrate embodiments of the invention, and, together with the general description of the invention given above, and the detailed description of the embodiments given below, serve to explain the principles of the present invention.

[0012] FIG. 1 is a perspective view of a surgical circular stapling instrument;

[0013] FIG. 2 is another perspective view of the circular surgical stapling instrument of FIG. 1 prior to the installation of an introducer embodiment of the present invention thereon;

[0014] FIG. 3 is a side elevational view of an introducer embodiment of the present invention;

[0015] FIG. 4 is a top view of the introducer of FIG. 2;

[0016] FIG. 5 is a top view of the introducer of FIGS. 3 and 4;

[0017] FIG. 6 is another top view of the introducer of FIGS. 2-5 with the cover panel removed from the handle assembly;

[0018] FIG. 7 is a partial perspective view of an introducer embodiment of the present invention installed on a circular stapling instrument;

[0019] FIG. 8 is a partial side elevation view of the introducer and circular stapler of FIG. 7;

[0020] FIG. 9 is a partial top view of the introducer and circular stapler of FIGS. 7 and 8;

[0021] FIG. 10 is an elevational view of a cap assembly embodiment of the present invention;

[0022] FIG. 11 is another elevational view of the cap assembly of FIG. 10 with the release latch removed therefrom;

[0023] FIG. 12 is a perspective view of the cap assembly of FIGS. 8-11 with the release latch removed therefrom and the cap disengaged from the barrel assembly;

[0024] FIG. 13 is a cross-sectional view of a cap assembly embodiment of the present invention with the cap engaged with the barrel assembly;

[0025] FIG. 14 is a partial side elevational view of a portion of a circular stapler and a cap of an introducer embodiment of the present invention;

[0026] FIG. 14A is another partial side elevational view of the circular stapler and cap with the cap sliding off the perimeter of the stapling head portion of the circular stapler;

[0027] FIG. 15 is a top view of a cap assembly embodiment of the present invention with the cap in an open position;

[0028] FIG. 16 is another top view of the cap assembly embodiment of FIG. 15 with a line illustrating a low profile cap embodiment;

[0029] FIG. 18 is a top perspective view of a cap assembly embodiment of the present invention;

[0030] FIG. 19 is a bottom view of the cap assembly of FIG. 18;

[0031] FIG. 20 is a top perspective view of another cap assembly embodiment of the present invention;

[0032] FIG. 21 is a bottom view of the cap assembly of FIG. 20;

[0033] FIG. 22 is a perspective view of a circular surgical stapling instrument prior to the installation of another introducer embodiment of the present invention thereon;

[0034] FIG. 23 is a perspective view of a circular surgical stapling instrument prior to the installation of another introducer embodiment of the present invention thereon;

[0035] FIG. 24 is an exploded elevational view illustrating another introducer embodiment of the present invention prior to installation on a portion of a stapling head of a circular stapler;

[0036] FIG. 25 is a cross-sectional view of the introducer of FIG. 24 installed on a stapling head of a circular stapler;

[0037] FIG. 26 is a distal end view of an introducer embodiment of the present invention;

[0038] FIG. 27 is a distal end view of another introducer embodiment of the present invention;

[0039] FIG. 28 is a distal end view of another introducer embodiment of the present invention;

[0040] FIG. 29 is a cross-sectional view of another introducer embodiment of the present invention installed on a stapling head of a circular stapler;

[0041] FIG. 30 is a side elevational view of another introducer embodiment of the present invention in a closed position;

[0042] FIG. 31 is another side elevational view of the introducer of FIG. 31;

[0043] FIG. 32 is another side elevational view of the introducer of FIGS. 30 and 31 in a closed position;

[0044] FIG. 33 is a distal end view of another introducer embodiment of the present invention attached to the stapling head of a circular stapler;

[0045] FIG. 34 is a side elevational view of another introducer embodiment of the present invention attached to the stapling head of a circular stapler with the trocar portion of the circular stapler in an extended position;

[0046] FIG. 35 is a distal end view of another introducer embodiment of the present invention attached to the stapling head of a circular stapler;

[0047] FIG. 36 is a side elevational view of another introducer embodiment of the present invention attached to the stapling head of a circular stapler with the trocar portion of the circular stapler in an extended position;

[0048] FIG. 37 is another side elevational view of the introducer and stapling head of FIG. 36 with the trocar portion of the circular stapler in a withdrawn position;

[0049] FIG. 38 is a side elevational view of another introducer embodiment of the present invention attached to a stapling head of a circular stapler;

[0050] FIG. 39 is a partial perspective view of another introducer embodiment of the present invention attached to the stapling head of a circular stapler;

[0051] FIG. 40 is another partial perspective view of the introducer embodiment of FIG. 39 being unwound from the stapling head of the circular stapler;

[0052] FIG. 41 is a partial perspective view of another introducer embodiment of the present invention attached to the stapling head of a circular stapler;

[0053] FIG. 42 is a partial perspective view of another introducer embodiment of the present invention attached to the stapling head of a circular stapler;

[0054] FIG. 43 is another partial perspective view of the introducer of FIG. 42 being withdrawn proximally from the stapling head of the circular stapler;

[0055] FIG. 44 is a partial perspective view of another introducer embodiment of the present invention attached to the stapling head of a circular stapler;

[0056] FIG. 45 is another partial perspective view of the introducer embodiment of FIG. 44 wherein a release motion has been initially applied thereto; and

[0057] FIG. 46 is another partial perspective view of the introducer of FIGS. 44 and 45 illustrating further application of the release motion thereto.

DETAILED DESCRIPTION

[0059] Certain exemplary embodiments will now be described to provide an overall understanding of the principles of the structure, function, manufacture, and use of the devices and methods disclosed herein. One or more examples of these embodiments are illustrated in the accompanying drawings. Those of ordinary skill in the art will understand that the devices and methods specifically described herein and illustrated in the accompanying drawings are non-limiting exemplary embodiments and that the scope of the various embodiments of the present invention is defined solely by the claims. The features illustrated or described in connection with one exemplary embodiment may be combined with the features of other embodiments. Such modifications and variations are intended to be included within the scope of the present invention.

[0060] The terms “proximal” and “distal” are used herein with reference to a clinician manipulating the handle portion of the surgical instrument. The term “proximal” referring to the portion closest to the clinician and the term “distal” referring to the portion located away from the clinician. It will be further appreciated that, for convenience and clarity, spatial terms such as “vertical”, “horizontal”, “up”, and “down” may be used herein with respect to the drawings. However, surgical instruments are used in many orientations and positions, and these terms are not intended to be limiting and/or absolute.

[0061] FIG. 1 illustrates a conventional circular stapler 10. The construction and operation of such circular staplers are generally known in the art. Thus, the specific components and features of such circular stapler will not be discussed in detail herein beyond what may be necessary to understand the construction and operation of the various embodiments of the

present invention. As the present Detailed Description proceeds, those of ordinary skill in the art will understand that the various embodiments of the present invention may be effectively employed with a variety of different circular stapler configurations without departing from the spirit and scope of the present invention. Accordingly, the scope of protection afforded to the various embodiments of the present invention should not otherwise be limited to use with the exemplary circular stapler depicted herein.

[0062] As can be seen in FIG. 1, a conventional circular stapler 10 generally includes a handle portion 12 that has an elongated shaft 14 protruding therefrom. A stapling head 16 is coupled to the distal end 15 of the elongated shaft 14 and is configured to operably support a staple cartridge 17 and movable knife assembly (not shown) therein. The circular stapler 10 further includes an anvil 20 that has an anvil body 22. The anvil 20 has an anvil shaft 24 that is configured to be removably attached to a trocar (not shown) that is movably supported within the elongated shaft 14 of the circular stapler 10. Movement of the trocar is achieved by rotating an adjustment knob 18 that is located at the proximal end of the handle portion 12. An indicator panel 19 may be provided on the handle portion 12 to provide the user with an indication of the position of the body portion 22 of the anvil 20 relative to the staple cartridge 17. Thus, when the anvil shaft 24 is attached to the movable trocar, the position of the anvil body 22 relative to the staple cartridge 17 in the stapling head assembly 16 may be adjusted by rotating the adjustment knob 18. The stapling head 16 further supports a staple driver assembly (not shown), the operation of which is controlled by a trigger assembly 26 on the handle portion 12. Further details concerning the operation and assembly of the exemplary circular stapler 10, for example, may be gleaned from reference to U.S. Patent Application Serial No. 12/408,905, filed March 23, 2009, entitled "Circular Surgical Stapling Instrument With Anvil Locking System" to John P. Measamer.

[0063] FIGS. 2-6 illustrate a circular stapler introducer 100 of the present invention that may be used in connection with a circular stapler 10. In various embodiments, the introducer 100 comprises an elongated hollow flexible sheath 110 that may be fabricated from, for example, a plastic material such as polyurethane blends, polyesters, polyethylene or polypropylene having a thickness of 0.004-0.015 inches and forms a first lumen 29 sized to be readily inserted over the elongated shaft 14 of a circular stapler 10. The sheath 110 has a distal end 114 and an open proximal end 112 as well as a top portion generally designated as 111 and a bottom portion 113. See FIG. 3. A handle assembly 130 may be attached to the open proximal end 112 by, for example, adhesive or ultrasonic welding, radio frequency (RF) welding or heat staking. The distal end 114 of the sheath 110 may be attached to a rigid cap assembly 130 by adhesive or by ultrasonic welding, radio frequency (RF) welding or heat staking. In various embodiments, a “weakened region” in the form of, for example, a perforated seam 116 may extend along the bottom portion 113 of the sheath 110 from the open proximal end 112 to the distal end 114. In addition, a second lumen 120 may be formed in the wall of the sheath 110 and extend from the open proximal end 112 to the distal end 114. In particular, the second lumen 120 may helically extend from the top portion 111 of the proximal end 112 to the bottom portion 113 at the distal end 114. The second lumen 120 may accommodate a release member 122 that extends from the handle assembly 130 to a latch member 140 that is movably supported in a distal end portion of the second lumen 120. In various embodiments, the release member 122 may comprise, for example, a suture. In other embodiments, the release member 122 may comprise a relatively thin flexible bar or similar member for transmitting a release motion to the latch member 140 attached thereto. The second lumen 120 may be formed in the wall of the sheath 110 by, for example, sewing, ultrasonic welding, radio frequency (RF) welding, heat staking, etc. The release member 122 and the latch member 140 may collectively form a release arrangement, generally designated as 121. See FIG. 10.

[0064] FIGS. 10-19, depict a rigid cap assembly 150 that may be used in connection with various embodiments of the present invention. The rigid cap assembly 150 may have a barrel member 152 that is attached to the distal end 114 of the sheath 110. The barrel member 152 comprises a partial ring-like member that has two opposed ends 154, 156. A rigid cap member 160 is “hingably attached” to the barrel member 152 by a tether 162. See FIG. 17. In various embodiments, the rigid cap assembly 150 is manufactured as a single injection

molded piece that has significantly different physical properties. In various embodiments, for example, the rigid cap assembly 150 may be injection molded from polyurethane blends, polyesters, polyethylene or polypropylene.

[0065] As will be discussed in further detail below, the cap member 160 is made rigid by increasing its cross-sectional area while the tether 162 and barrel member 152 are preferably designed to allow significant deflection in specific directions by reducing their respective cross-sections. The cap member 160 has a relatively blunt distal surface 164 that is substantially smooth to minimize the force required to insert the introducer 100 and the portions of the circular stapler 10 housed therein through the patient's sphincter as well as to facilitate navigation of the device through the Valves of Houston and other anatomy. The underside 166 of the cap member 160 may have a series of reinforcing ribs 168 formed therein to increase its cross-sectional area and make the cap member 160 substantially rigid. See FIGS. 13 and 19.

[0066] In various embodiments, the underside 166 of the cap member has a shape that substantially matches the shape of a portion of the perimeter of the stapling head 16. More specifically and as can be seen in FIG. 13, the underside 166, which is formed by reinforcing ribs 168, is arcuate in shape which matches a portion of the circular perimetrical shape of the stapling head 16 of the circular stapler 10. As can be further seen in FIG. 14, the cap member 160 has sides 170, 172 each has a cutout wall portion 174 that corresponds with the arcuate underside 166. Such arcuate underside 166 and cutout wall portions 174 enable the cap assembly 150 to pass proximally off the stapling head 16 when being proximally withdrawn over the circular stapler 10 to thereby reduce the radial distention of the bowel when the cap assembly 150 passes by the stapling head 16 of the circular stapler 10. For example, FIG. 16 provides an illustrative comparison between a cap assembly 150 with no arcuate underside 166 (represented by dotted line 180) and the cap assembly 150 with an arcuate underside 166. As illustrated, for one exemplary embodiment, the cap assembly without the arcuate underside has a 0.22" higher profile and would therefore further distend the bowel as it is withdrawn proximally over the stapling head 16.

[0067] In various embodiments, the tether 162 may be designed to be longer than the distance required to connect the cap member 160 to the barrel member 152 in the closed position (FIG. 10). That is, the tether 162 may coil inside the cap assembly 150 when the

rigid cap portion 160 is retained in the closed position. Such arrangement permits the cap member 160 to follow a substantially curved path while passing over the corner of the stapling head 16 of the stapler 10 and to move independently from the barrel member 152 during removal. See FIGS. 14 and 14A. In one embodiment, the tether 162 is diametrically opposite from the location wherein the latch member 140 engages the opposed ends 154, 156 of the barrel member 152. See FIGS. 18 and 19. In an alternative embodiment, the tether 162 is located 90 degrees from the latch 140 member. See FIGS. 20 and 21.

[0068] Various embodiments of the cap assembly 150 employ features which work together to ensure that the cap member 160 does not open during the insertion process while retaining the ability to be easily opened and removed at the appropriate time. For example, as can be seen in FIG. 13, various embodiments of the cap assembly 150 may include an inwardly-extending retainer flange 190 that is formed on portions of the barrel member 152. The retainer flange 190 may be positioned to retainingly engage corresponding retention ribs 167 formed on the lower rim of the cap member 160. As can be seen in FIG. 13, a series of gussets 194 may be formed with the retainer flange 190 to further stabilize and rigidify the retention flange 190. Various cap member embodiments may include at least one retention rib on the cap member 160 to retainingly secure the cap member 160 in a closed position wherein the cap member 160 covers the distal face 25 of the stapling head 16 (FIG. 10). In various embodiments, a series of three ribs 200, 202, 204 may be formed on the two portions of the cap member 160 that are between the tether 162 and the arcuate cut out portions 174. The two outer ribs 200, 202, 204 may be provided with chamfered lead-out portions 206. See FIG. 12. Such chamfered lead out portions 206 interface with the retention flange 190 on the barrel member 152 and may serve to minimize the chances of the cap member 160 binding on the retention flange 190 during the unlatching process without significantly jeopardizing the ability of the rib 167 and retention flange 190 arrangement to carry loads during the insertion process.

[0069] As can be seen in FIGS. 11 and 12, the opposed ends 154, 156 of the barrel member 152 are spaced from each other to define a latch region 210 for receiving the latch member 140 therein. The latch member 140 may be formed from a plastic material and have a body portion 141 that has a pair of distally protruding latch tabs 142, 144 formed thereon. See FIG. 11. The latch tabs 142, 144 are sized to extend into latch cavities 157, 159 formed in the opposing ends 154, 156 of the bar 152. See FIGS 10 and 11. Thus, when the latch tabs

142, 144 are received in the latch cavities 157, 159, the barrel member 152 forms a radially-openable ring-like structure sized to accommodate the stapling head 16 of the circular stapler 10 therein. In various embodiments, when the barrel member 152 is latched in the closed position wherein the cap member 160 covers the distal face 25 of the stapling head 16 of the circular stapler 10, the cap member 160 may sit directly on the distal face 25 of the stapling head 16 of the circular stapler 10 without interfering with any of the staple pockets in the staple cartridge 17 support therein. Such arrangement permits the forces experienced by the cap member 160 during the insertion process to be transmitted directly to the stapling head 16 of the circular stapler 10 without the need for any force balancing or intermediate components.

[0070] Also in various embodiments, the release member 140 may be further formed with a release finger 145 that may serve to assist with radially opening the barrel member 152 when the latch member 140 is pulled proximally out of engagement with the opposed ends 154, 156 of the barrel member 152. More specifically and with reference to FIG. 11, the latch member 140 may be formed with a release finger 145 that is centrally disposed between the latch tabs 142, 144. The release finger 145 may be formed with cam portions 147 that are designed to engage cam surfaces 161, 163 formed on the opposed ends 154, 156 of the barrel member 152 such that, as the latch member 140 is pulled in the proximal direction "P", the cam portions 147 engage the cam surfaces 161, 163 to urge the opposed ends 154, 156 of the barrel member 152 radially apart from each other (represented by arrows "R", in FIG. 12.). Thus the latch member 140 is pulled in a direction (proximal direction "P") that is substantially perpendicular to the direction of motion "R" required to disengage the cap member 160 from the barrel member 152. When the latch member 140 is removed and the clinician continues to apply an additional withdrawal motion to the introducer 100, the opposed ends 154, 156 of the barrel member 152 are permitted to further radially separate and enable the cap member 160 to disengage from the barrel member 152 and move to an open position. In doing so, the cap member 160 may be permitted to rotate to a lateral open position to facilitate proximal movement of the cap assembly 150 over the stapling head 16 as the introducer 100 is withdrawn proximally from the patient. See FIG. 14.

[0071] As can be seen in FIGS. 7-9, the handle assembly 130 may be designed to conform to the geometry of the handle portion 12 of the circular stapler 10 when the stapling head 16 has been inserted into the closed cap assembly 150 in a fully inserted position. For example,

when a lower rim portion of the rigid cap member 160 is in contact with the distal face 25 of the stapling head 16, the stapling head 16 may be considered to be in the “fully inserted” position. More broadly, the circular stapler 10 may be considered to be in a fully inserted position when the distal face 25 is in contact with a portion of the rigid cap member 160.

[0072] In various embodiments, the handle assembly 130 may be configured in such a way as to prevent improper installation of the introducer 100 on the circular stapler 10. For example, the handle assembly 130 may be “orientation-specific” such that it includes features which mate with corresponding surfaces on the handle portion 12 of the circular stapler 10 when the stapling head has been inserted to the fully inserted position, while at the same time interfering with other surfaces if the introducer 100 is installed incorrectly. In addition, many circular staplers 10 include an indicator panel 19 that is located on the upper side of the handle portion. See FIG. 1. Such indicator panel 19 may, for example, provide the clinician with an indication of the position of the anvil 20 relative to the stapling head 16. In various embodiments, the handle portion 130 of the introducer 100 may be designed to cover or obscure the indicator panel 19 of the circular stapler 10. Such arrangement serves to ensure that the user is aware that the introducer 100 is installed on the stapler 10 and thereby prevents the user from attempting to fire the circular stapler 10 without first removing the introducer 100. For example, the handle assembly 130 includes a forward portion 220 that covers or otherwise obscures the indication panel 19 of the circular stapler 10.

[0073] In various embodiments, the proximal end 124 of the release member 122 or suture is attached to a release slider 230. As can be seen in FIG. 6, the suture 122 may be attached to a forward tab portion 232 of the release slider 230 that is sized to be slidably received within a cavity 222 formed in the forward portion of the handle assembly 130. The forward tab portion 232 is slidably retained within the cavity 222 by a cover 240 that may be attached to the handle assembly 130 by a series of retainer tabs 242 that are oriented to snappingly engage corresponding snap cavities 224 in the handle assembly 130. See FIGS. 5 and 6

[0074] Various embodiments of the present invention may also incorporate a means for multiplying a proximal travel distance of the suture 122 relative to a distance that the release slider 230 is moved on the handle portion 12 of the circular stapler 10. For example, various embodiments may employ a pulley-type arrangement 250 to multiply the travel distance of the suture 122 relative the distance that the release slider 230 is moved in the proximal direction “P”. Such arrangement may allow for greater travel to ensure the release of the cap

member 160 without the need to lengthen the handle portion 130. For example, as shown in FIG. 6, the proximal end portion 124 of the suture 122 extends through a slot 252 in the handle assembly 130 and loops through a hole 234 in the forward slider tab 232. The end 124 of the suture 122 may then be attached to a fixed post 254 on the handle assembly 130

[0075] To facilitate easy removal of the introducer 100, the release slider 230 may be provided with a relatively “low profile” to enable the clinician to maintain a grip on the handle portion 12 of the stapler 10 without significantly changing their grip or method from what they would do with the circular stapler 10 alone. See FIGS. 7-9. Also, in various embodiments, the release slider 230 may be provided with a hole 236 and/or two lateral wing portions 238. Thus, this arrangement allows the clinician to apply force to the release slider 230 in the proximal direction “P” using either a single finger in the hole 236 or two fingers on the lateral wing portions 238.

[0076] As can also be seen in FIG. 6, the forward portion 220 of the handle assembly 130 may also be provided with stops 229 that are arranged to engage forward tabs 239 formed on the forward tab portion 232 of the release slider 230. Thus, in use, once the circular stapler 10 has been inserted into the introducer 100 to the fully inserted position and the stapler 10 and introducer 100 have been inserted to a desired position within the patient, the clinician may then pull the release slider 230 in a proximal direction to apply an amount of tension or release motion to the suture 122 to draw the latch member 140 to an unlatched position. Further pulling on the release slider 230 will result in the forward tabs 239 contacting the stops 229. Once the forward tabs 239 contact the stops 229, further pulling of the release slider 230 in the proximal direction causes the entire introducer 100 to move in the proximal direction. Such arrangement enables the entire introducer 100 to be decoupled from the stapler 10 and withdrawn from the patient by moving the release slider 230 in the proximal direction on the handle portion 12 of the circular stapler 10. The removal of the introducer 100 from the stapler 10 may be accomplished without removing the stapler 10 from the patient.

[0077] To use the introducer 100, the clinician simply inserts the circular stapler 10 into the sheath 110 to the fully inserted position and aligns the introducer 100 relative to the handle portion 12 such that the forward portion 220 of the handle portion 130 covers the indication panel 19 of the circular stapler 10. To aid in the insertion process, the stapling head 16 and

shaft portion 14 of the circular stapler 10, as well as the cap assembly 150 and sheath 110 of the introducer 100, may be lubricated prior to commencing the insertion process. When the circular stapler 10 has been properly inserted into the introducer 100, the rim of the cap 160 which is engaged with the flange 190 of the barrel assembly 152 and thereby retained in the closed position as illustrated in FIGS. 3-6, 10 and 13, will rest on the stapling head 16 of the stapler 10. The user then inserts the stapler 10 and introducer 100 into a desired position in the colon. Once the stapler 10 is in a desired position, the clinician may pull on the release slider 230 in the proximal direction "P" which causes the suture 122 to pull the retainer latch 140 out of engagement with the ends 154, 156 of the barrel assembly 152. As the retainer latch 140 is drawn proximally, the cam surfaces 147 on the release finger 145 cooperate with the cam surfaces 161, 163 formed on the opposed ends 154, 156 of the barrel assembly 152 such that, as the release member 140 is pulled in the proximal direction "P", the ends 154, 156 are urged radially apart. Further pulling of the release slider 230 results in the forward tabs 232 contacting the stops 229 such that further pulling of the slider 230 results in the entire introducer 100 being pulled proximally over the circular stapler 10. Such pulling of the introducer 100 may cause the sheath 110 to separate along the line of perforations 116 and the cap 160 to move to an open position (FIGS. 14 and 15) to thereby enable the introducer 100 to be withdrawn from the patient prior to firing the stapler 10.

[0078] FIG. 22 illustrates another introducer 300 of the present invention. In this embodiment, the introducer 300 comprises a hollow sheath 302 that has a closed end 304 and an open end 306 for insertion onto the circular stapler 10. The sheath 302 may be fabricated from a flexible material such as from those materials commonly employed to fabricate condoms. In one embodiment, the sheath 302 is fabricated from a single piece of material that has an elongate seam 310 that extends the length of the sheath 302. In particular, the sheath material is folded over such that the end 312 of the material overlaps end 314 of the material represented by distance "O" in FIG. 22. The ends 312, 314 are then stitched together by a suture 316 forming the seam 310. Thus, the sheath 302 is inserted over the stapling head 16 of the stapler 10 prior to insertion into the patient. After the stapler 10 and sheath 302 have been inserted into position, the sheath 302 may be removed by pulling the suture 316 to thereby release the seam 310 to permit the sheath 302 to be removed. In other embodiments, the sheath 302 is fabricated from two pieces of flexible material that are

stitched together with two sutures 316 in the manner described above. To remove the sheath 302, the clinician simply pulls on one or both of the sutures 316.

[0079] FIG. 23 illustrates another introducer 320 of the present invention. In this embodiment, the introducer 320 comprises a hollow sheath 322 that has a closed end 324 and an open end 326 for insertion onto the circular stapler 10. The sheath 322 may be fabricated from a flexible material such as that material commonly employed to fabricate condoms. In one embodiment, the sheath 320 has a closed end 342 and an open end 326 and is provided with at least one weakened area 328 which may comprise a perforated line or seam that extends the length of the sheath 322. Thus, the sheath 322 is inserted over the stapling head 16 of the stapler 10 prior to insertion into the patient. After the stapler 10 has been inserted into position, the sheath 322 may be removed by pulling on the weakened area 328 to permit the sheath 322 to be separated from the stapler 12.

[0080] FIGS. 24-28 illustrate another introducer 330 of the present invention. In this embodiment, the introducer 330 comprises a sheath 332 that has a closed distal end 334 and an open proximal end 336 that is sized to be stretched over at least a distal portion of the stapling head 16 of the circular stapler 10. The sheath 332 may be fabricated from, for example, silicone, latex or other relatively low durometer material (i.e., a durometer of 90A). In various embodiments, a circumferentially-extending raised bumper area 338 may be formed around the circumference of the closed distal end 334 as shown in FIGS. 24 and 25. In some embodiments, a central portion 335 extends inwardly from the circumferentially-extending bumper area 338 to enclose an open central area 27 in the stapling head 16. See FIG. 25.

[0081] As can also be seen in FIG. 25, the bumper area 338 extends distally beyond (or in other words is "raised above") a plane D-D defined by a distal face 25 of the stapling head 16. In some embodiments, the bumper area 338 is formed from solid material. See FIG. 26. In other embodiments, a circumferentially-extending hollow area 340 is formed therein. In other embodiments, hollow area 340 comprises a plurality of pockets 341. See FIG. 28. The area 340 and pockets 341 may be filled with air or a liquid such as saline solution for example. In use, the sheath 332 is rolled over the stapling head 16 of the stapler 10. The sheath 332 may be left in place while closing and firing the stapler 10 in which case the area

340 or pockets 341 would be broken leaving only the sheath material behind under the staple crown inside the rectal lumen.

[0082] FIG. 29 illustrates another introducer 350 of the present invention. In this embodiment, the introducer 350 comprises a sheath 352 that has a distal end 354 and an open proximal end 356 that is sized to be stretched over the stapling head 16 of the circular stapler 10. The sheath 352 may be fabricated from, for example, silicone, latex or other relatively low durometer material (i.e., a durometer of 90A). In various embodiments, a circumferentially-extending raised bumper area 357 may be formed around the circumference of the sheath 352 such that it covers the distal face 25 of the stapling head 16 and a portion 359 extends into the central open area 27 and below the plane D-D defined by the distal face 25. See FIG. 29. In some embodiments, the bumper area 357 is formed from solid material. In other embodiments, a circumferentially-extending hollow area 358 is formed therein. The hollow area 358 may be filled with air or a liquid such as saline solution. In other embodiments, the circumferentially extending hollow area 358 is segmented (e.g., comprises a series of discrete pockets that extend around the circumference of the sheath 352). The discrete pockets may be filled with air or liquid such as saline solution for example. In use, the sheath 352 is rolled over the distal end portion of the stapling head 16. The sheath 352 may be left in place while closing and firing the stapler 10 in which case the hollow area 358 or pockets would be broken leaving only the sheath material behind under the staple crown inside the rectal lumen.

[0083] FIGS. 30-32 illustrate another introducer 360 of the present invention. In this embodiment, the introducer 360 comprises a cover 362 that is sized to be installed on at least a distal portion of the stapling head 16. In one embodiment, the cover 362 comprises a "C"-shaped body portion 363 that may be fabricated from, for example, polyurethane blends, polyesters, polyethylene, polycarbonate or polypropylene and be sized to be snapped onto the stapling head 16 and portion of the elongated shaft 14 of the circular stapler 10. See FIG. 31. In various embodiments, the distal end 364 of the body portion 363 has at least three normally closed fingers 366 that, when moved distally on the stapling head 16, close together forming, for example, a "tulip-like" shape for insertion into the anus. See FIG. 30. The body portion 363 may have a retraction member 370 formed thereon for facilitating the application of a retraction motion thereto. When the stapler 10 has reached its targeted insertion point, the cover 362 may be pulled toward the handle portion 12 of the stapler 10, thus pulling the

fingers 366 to the vertical sides of the stapling head 16 exposing the distal face 25 of the staple cartridge 17. See FIG. 32.

[0084] FIGS. 33 and 34 illustrate another introducer 380 of the present invention. In this embodiment, the introducer 380 comprises a cover 382 that includes four fingers 384 that extend from a centrally disposed hub 386 that has a trocar access hole 388 therethrough. The proximal end 390 of each of the fingers 384 has a retention flange 392 formed thereon that extend into the central opening 27 and engage the central wall portion 21 of the stapling head 16. To install the cover 382, the cover 382 is positioned over the stapling head 16 as shown in FIGS. 33 and 34 and the trocar 23 of the circular stapler 10 is advanced such that the distal end portion 35 of the trocar 23 protrudes through the hole 388 in the central hub 386. Once in position, the trocar 23 is retracted proximally into central opening 27 to thereby force the fingers 384 into a generally bulbous, "mushroom-like" cross-sectional shape. Once the stapler 10 is positioned in the rectum, the trocar 23 can then be deployed and pushed thru the rectal wall allowing access to the accessory fingers 384 which can be removed from the trocar 23.

[0085] FIGS. 35-37 illustrate another introducer 400 of the present invention. In this embodiment, the introducer 400 comprises a cover 402 that include four fingers 404 that are attached together by a sheath 410. See FIG. 35. The sheath may be made from, for example, silicone material. The apex area 412 of the sheath 410 may have a trocar access hole 414 therethrough. The proximal end 406 of each of the fingers 404 has a retention flange 408 formed thereon that extend into the central opening 21 in the stapling head 16. To install the cover 400, the cover 402 is positioned over the stapling head 16 as shown in FIGS. 35 and 36 and the trocar 23 of the circular stapler 10 is advanced distally such that the distal end portion 35 of the trocar 23 protrudes through the hole 414 in the sheath 410. Once in position, the trocar 23 is retracted to thereby force the fingers 404 into a generally mushroom cross-sectional shape. See FIG. 37. Once the stapler 10 is positioned in the rectum, the trocar 23 can then be deployed and pushed thru the rectal wall allowing access to the accessory fingers 404 which can be removed from the trocar 23.

[0086] FIG. 38 illustrates another introducer 420 that may be fabricated from, for example, polyurethane blends, polyesters, polyethylene, polycarbonate or poly propylene that has at least four fingers 422 that are interconnected at a hub or apex area 424. The proximal ends

426 of the fingers 422 snap onto the stapling head 16. In this embodiment, the introducer 420 is designed to go up the colon and then be removed. This is unlike the introducer 400 described above wherein the trocar is in the extended position to hold it in place until the device is in position and then the trocar is brought proximally.

[0087] FIGS. 39 and 40 illustrate another introducer 500 that may be used in connection with a circular stapler 10. As can be seen in those Figures, the introducer 500 may comprise a molded arrangement with perforations and may be fabricated from, for example, polyurethane blends, polyesters, polyethylene or polypropylene or alternatively could comprise wound strip that is sewn together or held in place without covering. The strip 504 may have a width of, for example, .250 inches and a thickness of, for example, 0.020 inches. The strip 504 may form a base portion 506 sized to extend around the circumference of the stapling head 16. The base portion 506 may be sized relative to the stapling head 16 such that, when held together in close spiral relationship, the spiral strip 504 forms a relatively tight (interference) fit with the stapling head 16 to retain the introducer thereon. The spirally wound strip 504 forms a plurality of successive passes 508 that tapers to a blunt distal end 510. As can be seen in FIG. 36, one embodiment resembles a blunt-ended “beehive-shape” that substantially encloses or covers the distal face of the stapling head 16. The spiral passes 508 may be held in substantial abutting relationship (i.e., spirally wound closed ended relationship) by a retainer member 510. In various embodiments, the retainer member 510 may comprise a thin (e.g., 1 to 4 Mils) layer of shrink wrap that extends over the introducer 500. The introducer 500 also includes a release member 520 that is attached to the strip material 504 such that upon application of a release motion thereto, the spiral wound strip member 504 is unwound from engagement with the distal portion of the stapling head 16. In one embodiment, for example, the release member comprises a release suture 520 that is attached to the distal end 512 of the strip 504. The release suture 520 may pass through a hole 522 in a portion of the strip 504 forming the base portion 506 and extend proximally out to the handle portion of the stapler 10 to enable the release suture 520 to be grasped by the clinician.

[0088] The introducer 500 may be installed by the supplier of the stapler 10 by shrink wrapping the introducer 500 to the stapling head 16. In use, the clinician inserts the stapler and introducer assembly 530 into the patient’s anus and past the Valves of Houston to the desired area. Once the clinician has determined that the stapler 10 is in the desired position,

the clinician can then pull the release suture 520 in the proximal direction "P" which causes the shrink wrap 510 to rupture thereby permitting the introducer 500 to unwind as illustrated in FIG. 40. Continued pulling on the release suture 520 will enable the introducer 500 to be withdrawn from the patient.

[0089] FIGS. 41-43 illustrate another introducer 600 that may be used in connection with a circular stapler 10. As can be seen in those Figures, the introducer 600 may have a base portion 602 sized to be retained on the stapling head 16. The introducer 600 is formed with a plurality of tapered "petal" portions 504 that taper to a substantially rounded point 606. In some embodiments, for example, there are four diametrically opposed petal portions 604 that, when closed (FIG. 41), converge to form a relatively blunted pointed end 610. The petal portions 604 have an open area 612 therebetween. In various embodiments, the petal portions 604 are retained in the closed position by a releaseable retainer member 620. In some embodiments for example, the retainer member comprises shrink-wrap material 620 that is applied around the introducer 600. In some embodiments, a plurality of retention ledges 630 may be formed around the inner perimeter of the base 602 to engage the distal face 25 of the stapling head 16 when the shrink wrap 620 has been applied. Release sutures 640 may be sewed through those portions 622 of the shrink-wrap 620 that cover the open area 612. The release sutures 640 terminate in or are each attached to a release suture 650 that passes through a hole 652 in the base portion 602 and extends proximally out to the handle portion of the stapler 10 to enable the release suture 650 to be grasped by the clinician.

[0090] The introducer 600 may be installed by the supplier of the stapler 10 by shrink wrapping the introducer 600 to the stapling head 16. In use, the clinician inserts the stapler and introducer assembly 660 into the patient's anus and past the Valves of Houston to the desired area. Once the clinician has determined that the stapling head of the stapler 10 is in the desired position, the clinician can then pull the release suture 650 in the proximal direction "P" which causes the shrink-wrap 620 to rupture thereby permitting the introducer 600 to be pulled distally over the stapling head 16 as illustrated in FIG. 43.

[0091] FIGS. 44-46 illustrate another introducer 700 that may be used in connection with a circular stapler 10. As can be seen in those Figures, the introducer 700 may be fabricated from, for example, polyurethane blends, polyesters, polyethylene or polypropylene and have a base portion 702 sized to be retained on the stapling head 16. The introducer 700 is formed

with a plurality of tapered “segment” portions 704 that taper to a substantially rounded point 706. In some embodiments, for example, there are four diametrically opposed segment portions 604 that, when closed (FIG. 44), converge to form a relatively blunted pointed end 710. In the embodiment depicted in FIGS. 44-46, the introducer 700 includes four segment portions 704. The segment portions 704 are interconnected at their base portions except for two adjacent segment portions 704 wherein the bases of the two segment portions 704 are not attached together. More particularly, segment portion 704A has a base edge 705A and segment portion 704B has a base edge 705B. Edges 705A and 705B are not attached to each other. Thus, segment portion 704A and segment portion 704B comprise free ends of the base portion 702. The free ends 704A and 704B are retained in abutting relationship by a retainer member in the form of a radial release tab 720 that is attached to 704A and 704B. In various embodiments, the release tab 720 is fixed or molded to segment portion 704A and may not necessarily be removed therefrom. The release tab 720 is releaseably attached to segment portion 704B. The release tab 720 may be attached to the segment portion 704 by a releasable retainer 722 such as, for example, a releasable adhesive or piece of rupturable material. When the release tab 720 is attached as shown in FIG. 41, the segment portions 704 form an annular base portion 702 that may be retainingly snapped onto or otherwise retainingly engage the stapling head 16 of the circular stapler 10. A release suture 730 is attached to the release tab 720 and extends proximally out to the handle portion 12 of the stapler 10 to enable the release suture 730 to be grasped by the clinician.

[0092] The introducer 700 may be snapped onto or pressed onto the stapling head 16 by the clinician. In use, the clinician inserts the stapler and introducer assembly 740 into the patient’s anus and past the Valves of Houston to the desired area. Once the clinician has determined that the stapling head 16 of the stapler 10 is in the desired position, the clinician can then pull the release suture 730 in the proximal direction “P” which causes the release tab 720 to release from the segment portion 704B to enable the introducer 700 to release from the stapling head 16. Continued pulling on the release suture 730 will enable the introducer 700 to be withdrawn from the patient.

[0093] Thus, the various embodiments of the circular stapler introducer of the present invention may facilitate the transanal and transabdominal insertion and navigation to access the staple line of the distal stump in lower anterior resections. The various introducers may

be provided as a part of a kit that also includes a circular stapler 10. Various embodiments of the introducer will have no impact on the current functions of the circular stapler.

[0094] The various embodiments of the present invention represent a vast improvement over prior circular staple arrangements that fail to provide any means for locking the anvil in a firing position. While several embodiments of the invention have been described, it should be apparent, however, that various modifications, alterations and adaptations to those embodiments may occur to persons skilled in the art with the attainment of some or all of the advantages of the invention. For example, according to various embodiments, a single component may be replaced by multiple components, and multiple components may be replaced by a single component, to perform a given function or functions. This application is therefore intended to cover all such modifications, alterations and adaptations without departing from the scope and spirit of the disclosed invention as defined by the appended claims.

[0096] The invention which is intended to be protected is not to be construed as limited to the particular embodiments disclosed. The embodiments are therefore to be regarded as illustrative rather than restrictive. Variations and changes may be made by others without departing from the spirit of the present invention. Accordingly, it is expressly intended that all such equivalents, variations and changes which fall within the spirit and scope of the present invention as defined in the claims be embraced thereby.

What is claimed is:

1. An introducer for introducing a surgical circular stapler having a handle portion, an elongated shaft protruding from the handle portion, and stapling head coupled to the elongated shaft into a patient, said introducer comprising:

a hollow flexible sheath having a distal end and an open proximal end, said hollow flexible sheath sized to receive the stapling head and at least a portion of the elongated shaft therein;

a radially-openable barrel member comprising a partial ring-like member that has two opposed ends attached to a distal end of said hollow flexible sheath and defining an opening for receiving the stapling head therein,

a rigid cap member hingably attached to said radially-openable barrel member and movable between a closed position wherein said rigid cap member covers a distal end of said opening in said barrel member and open position wherein said rigid cap member is movable to a position exposing said distal end of said opening in said barrel member; and

a latch member in engagement with the two opposed ends of said radially-openable barrel member, said latch member being selectively movable from a latched position engaging said opposed ends of said barrel member and retaining said rigid cap member in said closed position and an unlatched position wherein said opposed ends are movable radially away from each other to enable said rigid cap member to move to said open position.

2. The introducer of claim 1 wherein said latch member comprises:

a latch body;

a first latch tab protruding from said latch body and having a first portion insertable into a first latch cavity provided in one of said opposed ends of said barrel member; and

a second latch tab protruding from said latch body and having a second portion insertable into another latch cavity in the other of said pair of opposed ends of said barrel member such that, when said first latch tab is in said first latch cavity and said second latch tab is in said second latch cavity, said barrel member forms a ring-like structure sized to accommodate the stapling head therein.

3. The introducer of claim 2 further comprising a release finger on said latch body, said release finger configured to engage portions of said pair of opposed ends when

said latch member is moved to an unlatched position to thereby urge said pair of opposed ends radially apart from each other.

4. The introducer of claim 3 wherein said release finger is centrally disposed between said first and second latch tabs and further has a pair of central cam surfaces thereon wherein one said central cam surface is configured to cammingly engage a corresponding end cam surface on one of said opposed end and another one of said central cam surface is configured to cammingly engage another end cam surface on the other one of said opposed end when said latch member is moved to said unlatched position.

5. The introducer of claim 1 further comprising an inwardly-extending retaining flange formed on an inside surface of at least a portion of said radially-openable barrel member, said retaining flange configured to retainingly engage a portion of said rigid cap member to retain said rigid cap member in said closed position.

6. The introducer of claim 5 wherein said rigid cap member has at least one retention rib thereon oriented for retaining engagement with said inwardly extending retaining flange on said radially-openable barrel position when in said closed position.

7. The introducer of claim 6 wherein said at least retention rib has at least one chamfered surface thereon to facilitate disengagement from said inwardly extended retention flange when said latch member has been moved to said unlatched position.

8. The introducer of claim 1 such that at least a portion of said rigid cap member contacts the distal face of the stapling head when the stapling head is in a fully inserted position within said introducer.

9. The introducer of claim 2 wherein said pair of opposed ends of said barrel member define a latch area therebetween for receiving the latch member therein and wherein said cap member is hingably attached to said barrel member by a tether attached to said barrel member in a position that is substantially diametrically opposite from said latch area.

10. The introducer of claim 2 wherein said pair of opposed ends of said barrel member define a latch area therebetween for receiving the latch member therein and wherein said cap member is hingably attached to said barrel member by a tether attached to said barrel member in a position that is located a substantial right angle from said latch area.

11. The introducer of claim 5 further comprising at least one gusset member attached to said inwardly extending retaining flange and said inside surface of at least a portion of said radially-openable barrel member.

12. The introducer of claim 2 wherein said latch member is movably supported within a lumen formed in said hollow flexible sheath.

13. The introducer of claim 2 further comprising a release member attached to said body portion of said latch member and extending proximally beyond said open proximal end of said hollow flexible sheath.

14. The introducer of claim 12 further comprising a release member attached to said body portion of said latch member and extending through said lumen to said open proximal end of sheath.

15. The introducer of claim 14 wherein said release member comprises a suture.

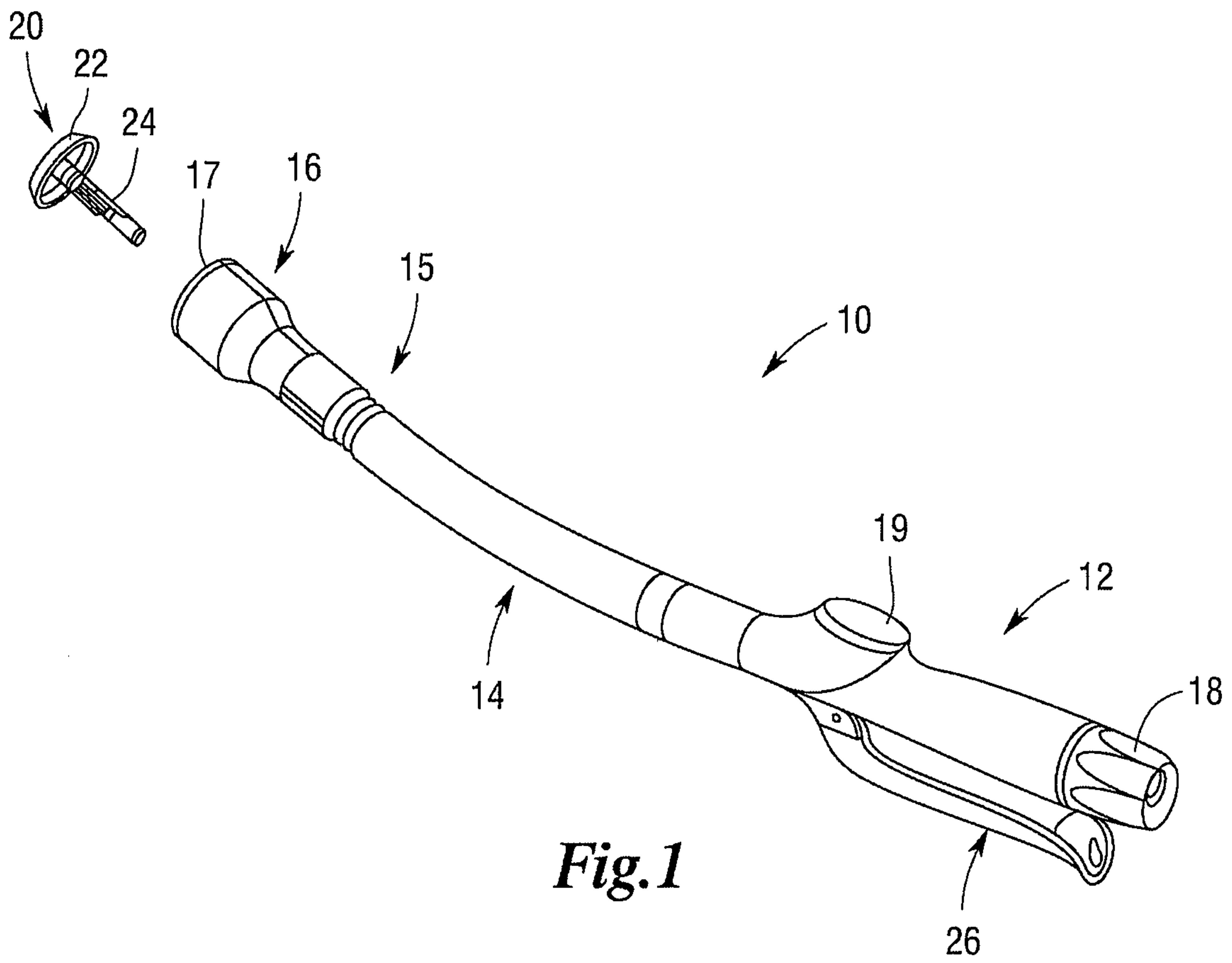

Fig.1

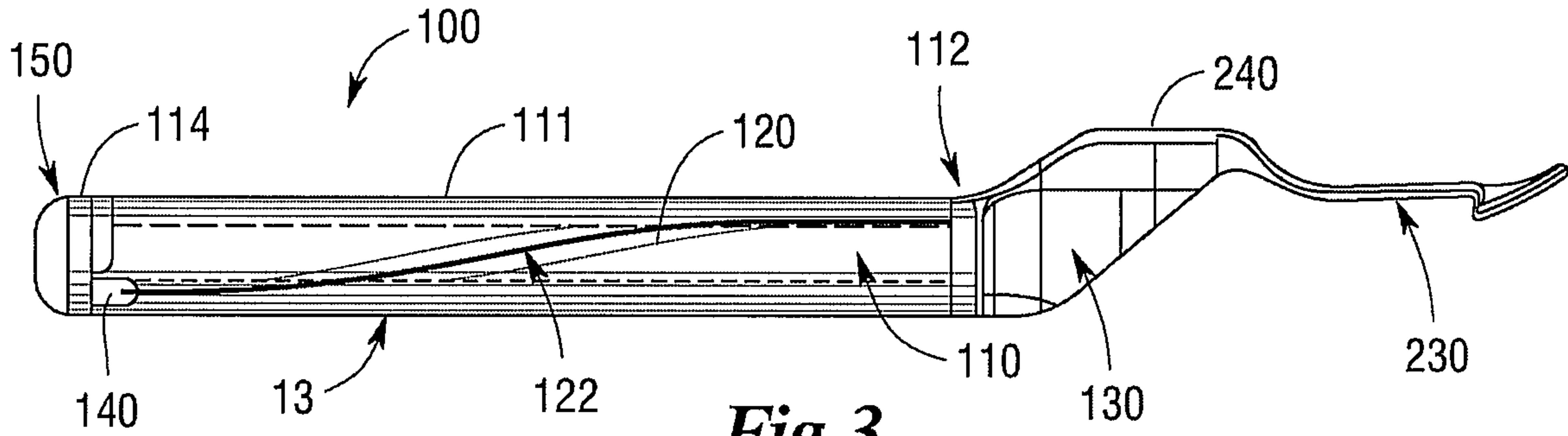

Fig. 3

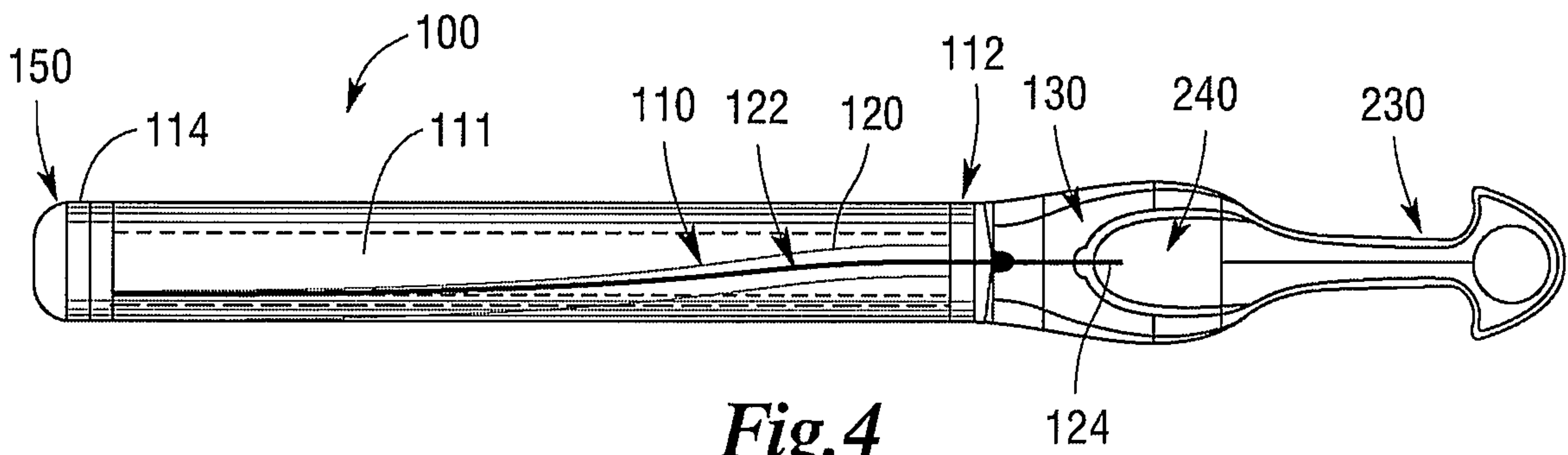

Fig. 4

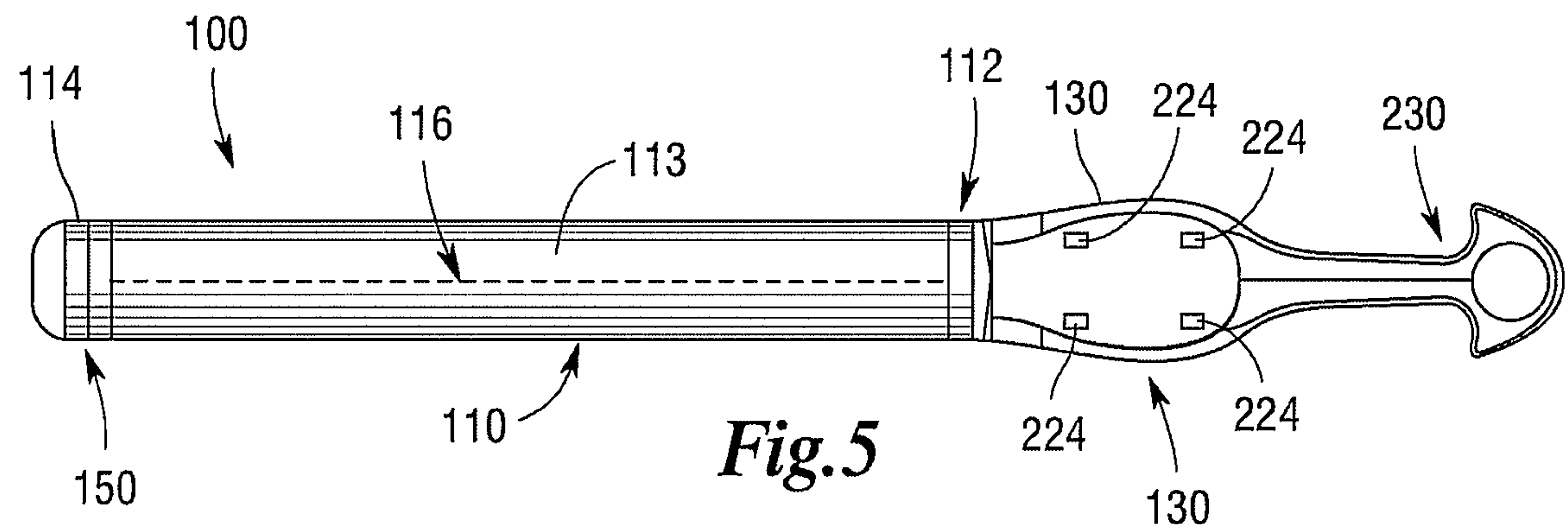

Fig. 5

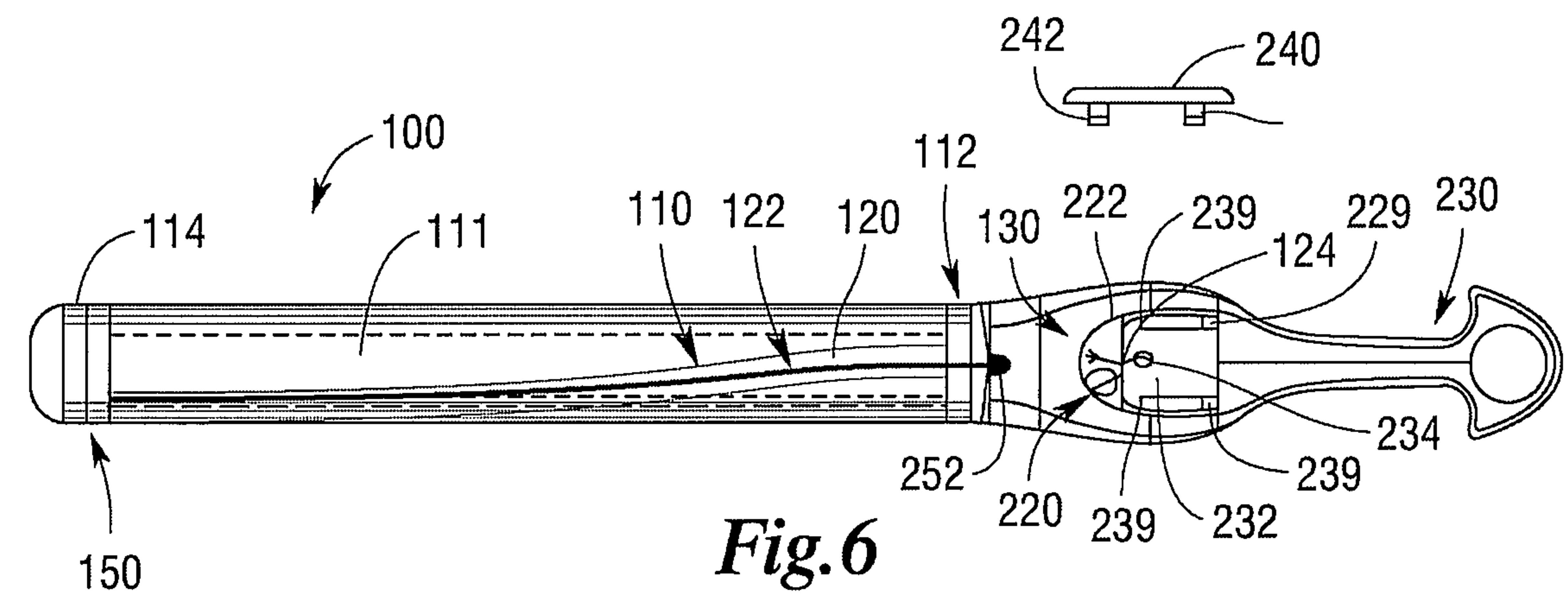

Fig. 6

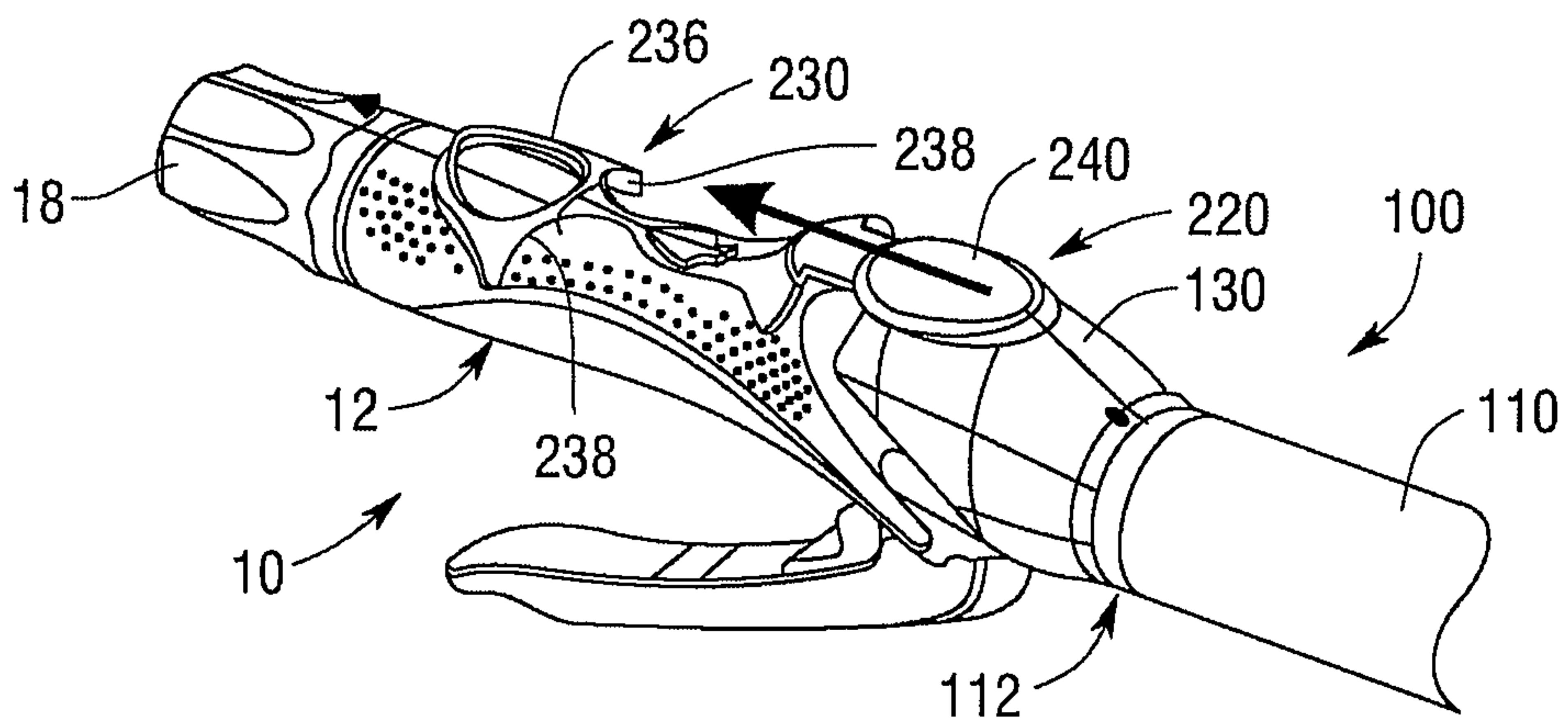

Fig. 7

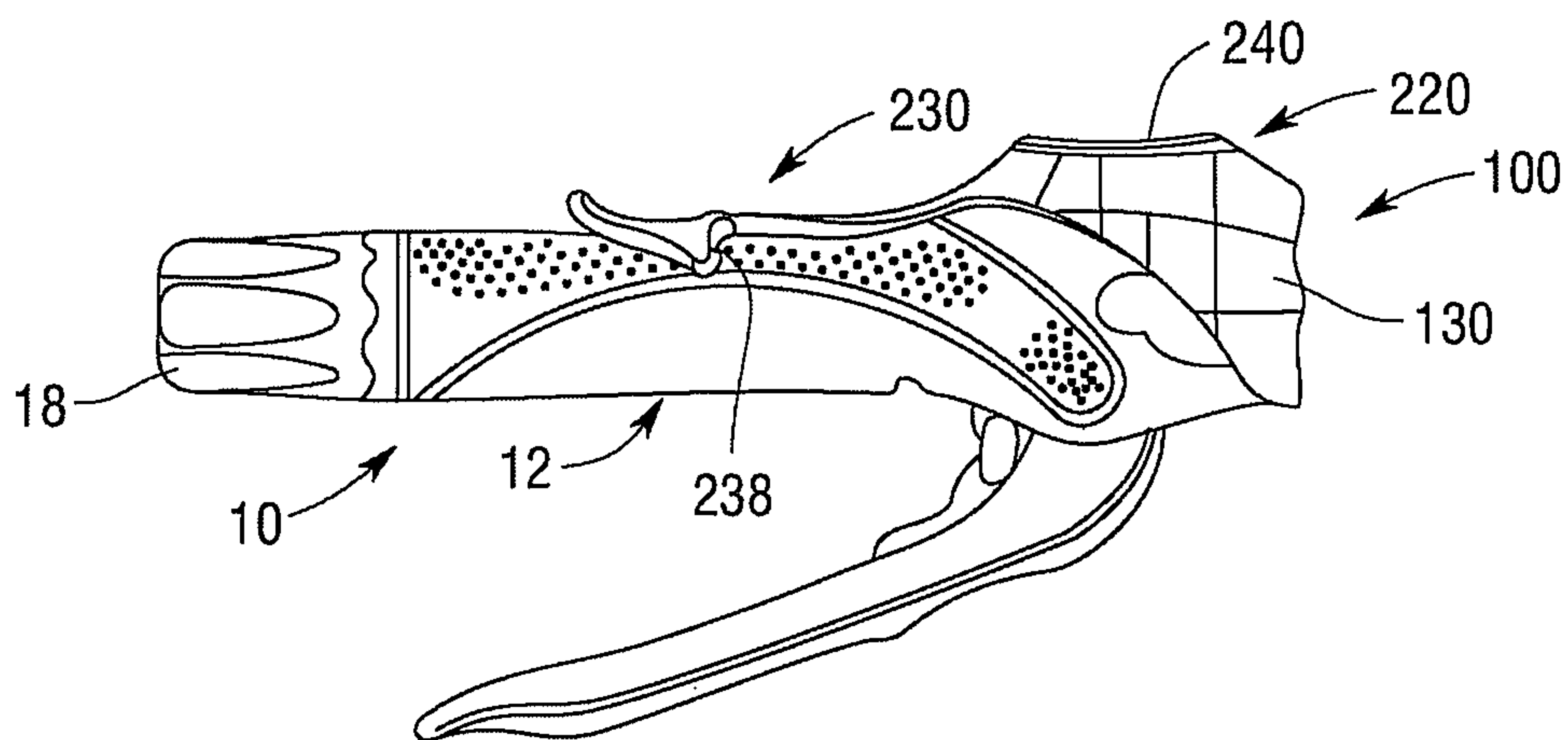

Fig. 8

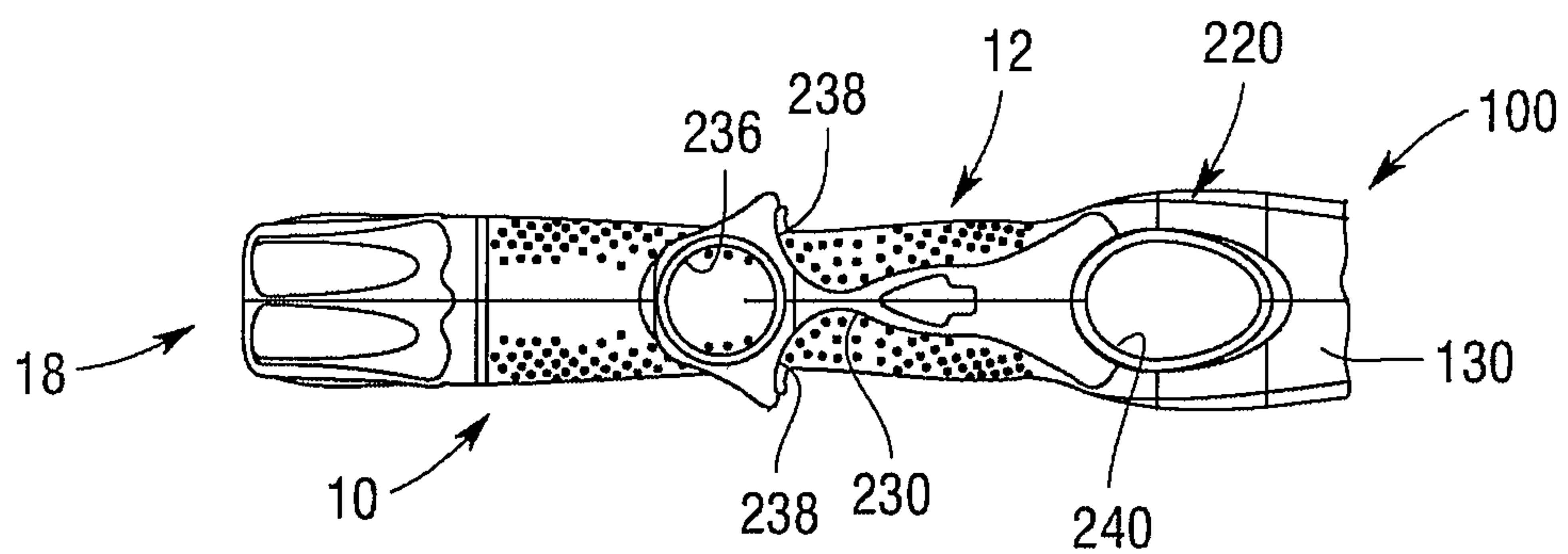

Fig. 9

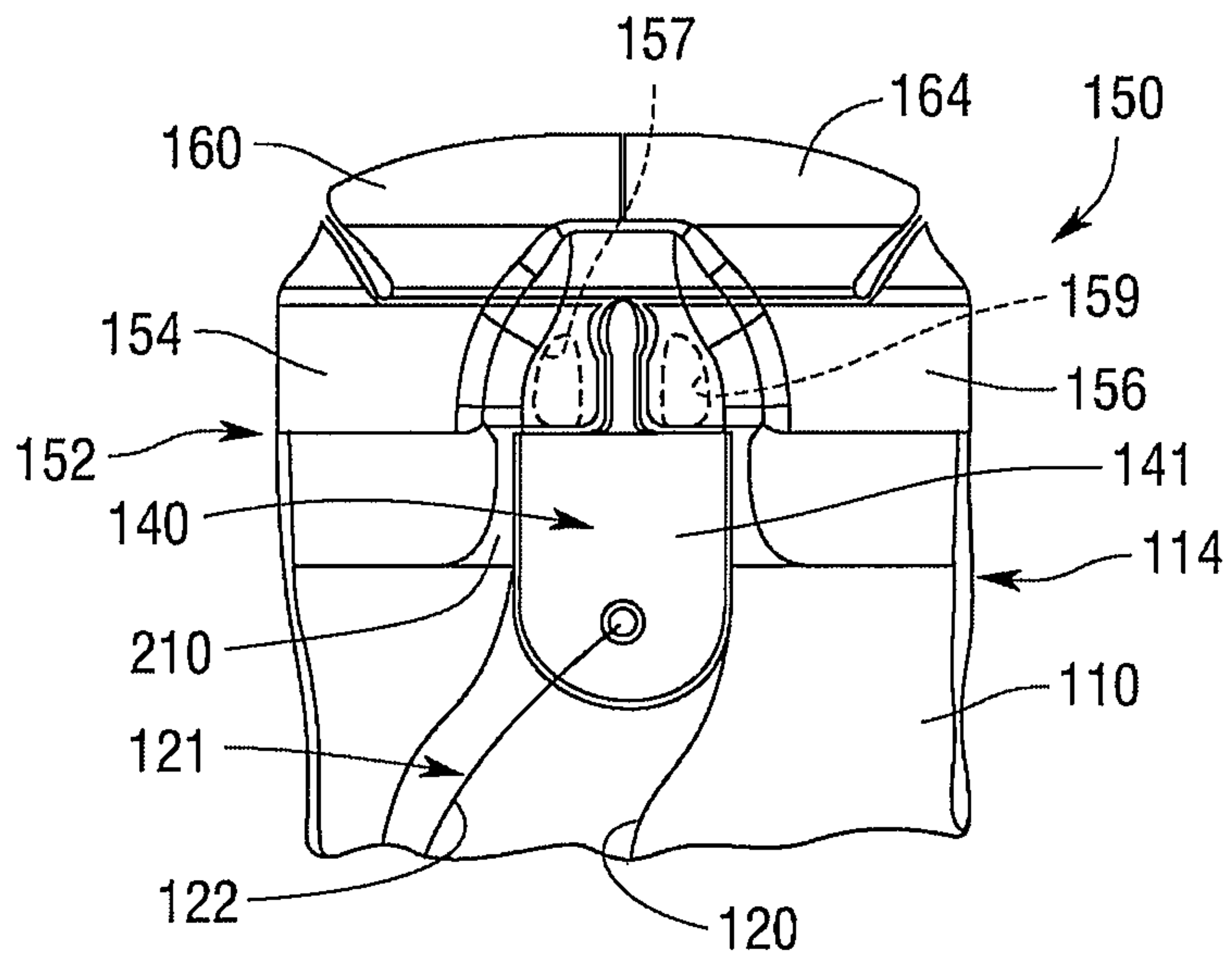
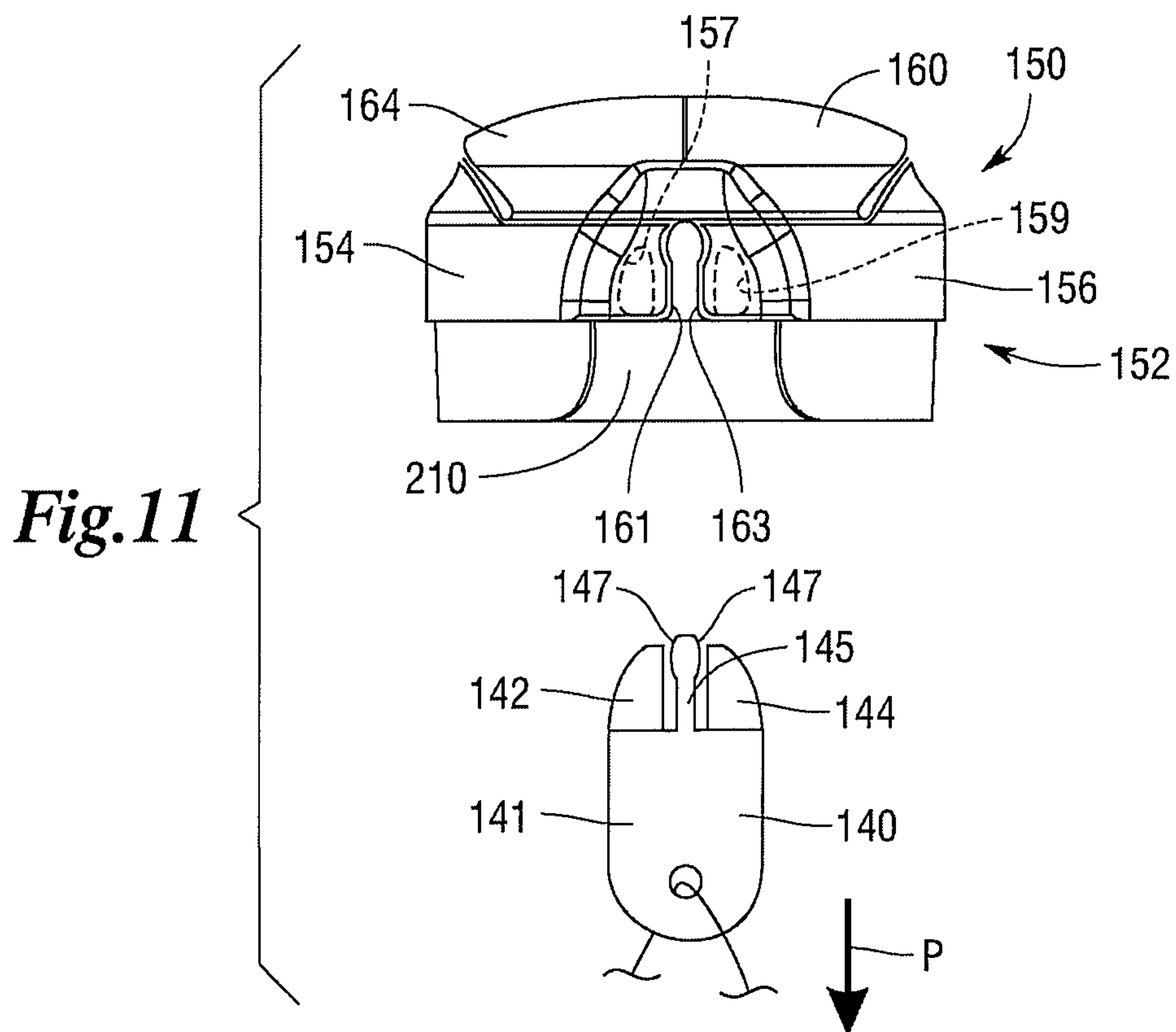

Fig. 10



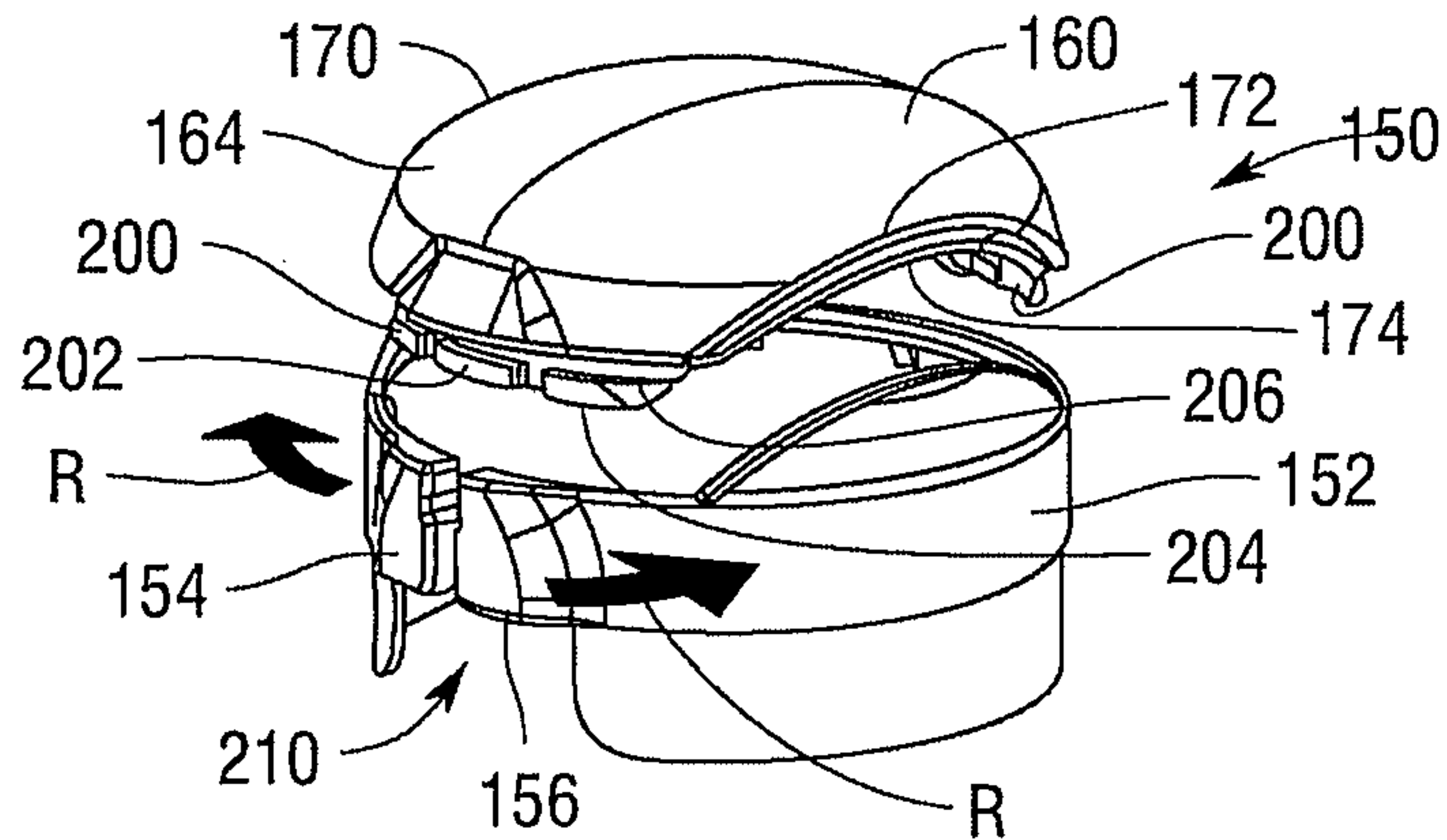

Fig. 12

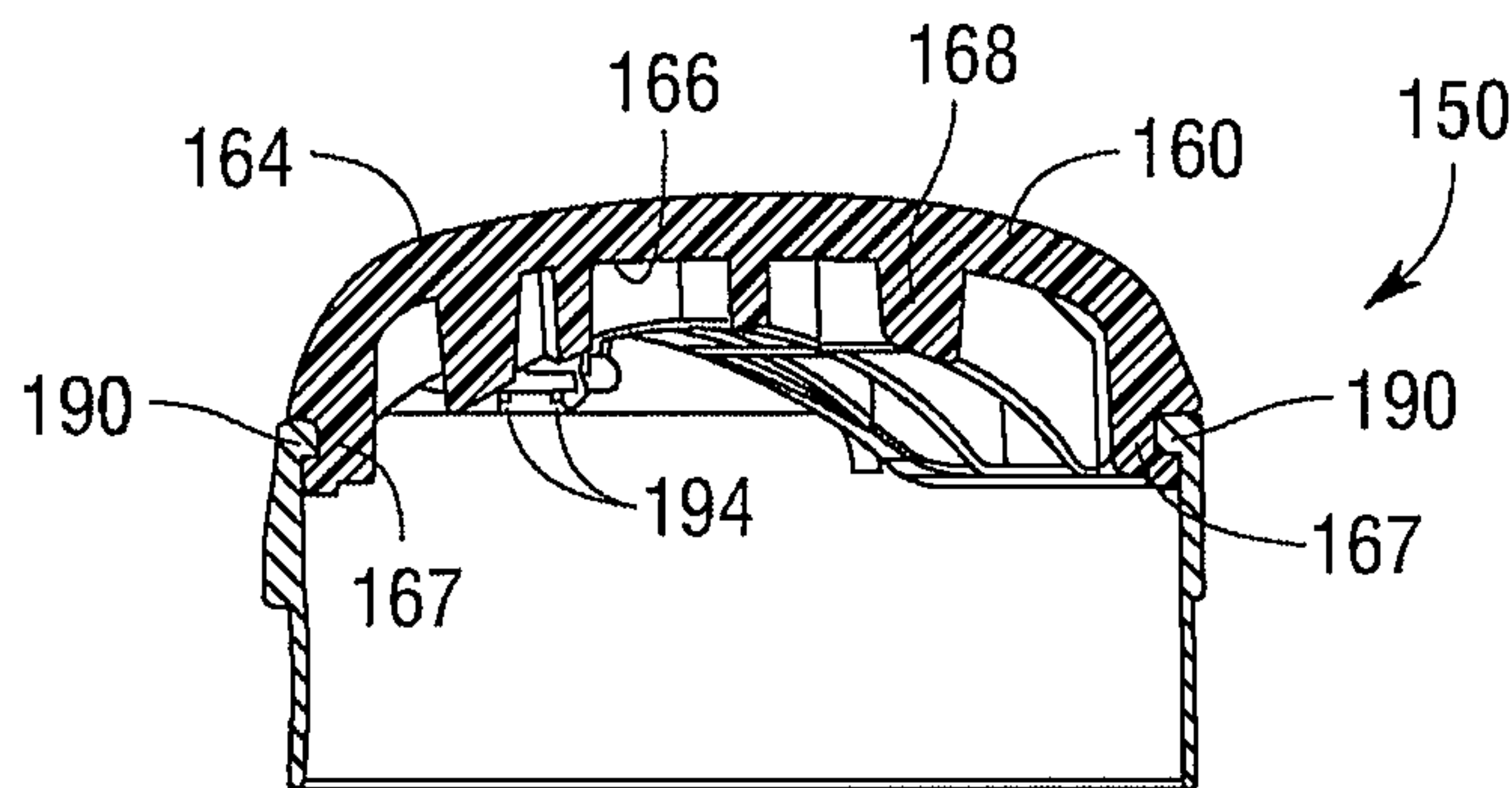

Fig. 13

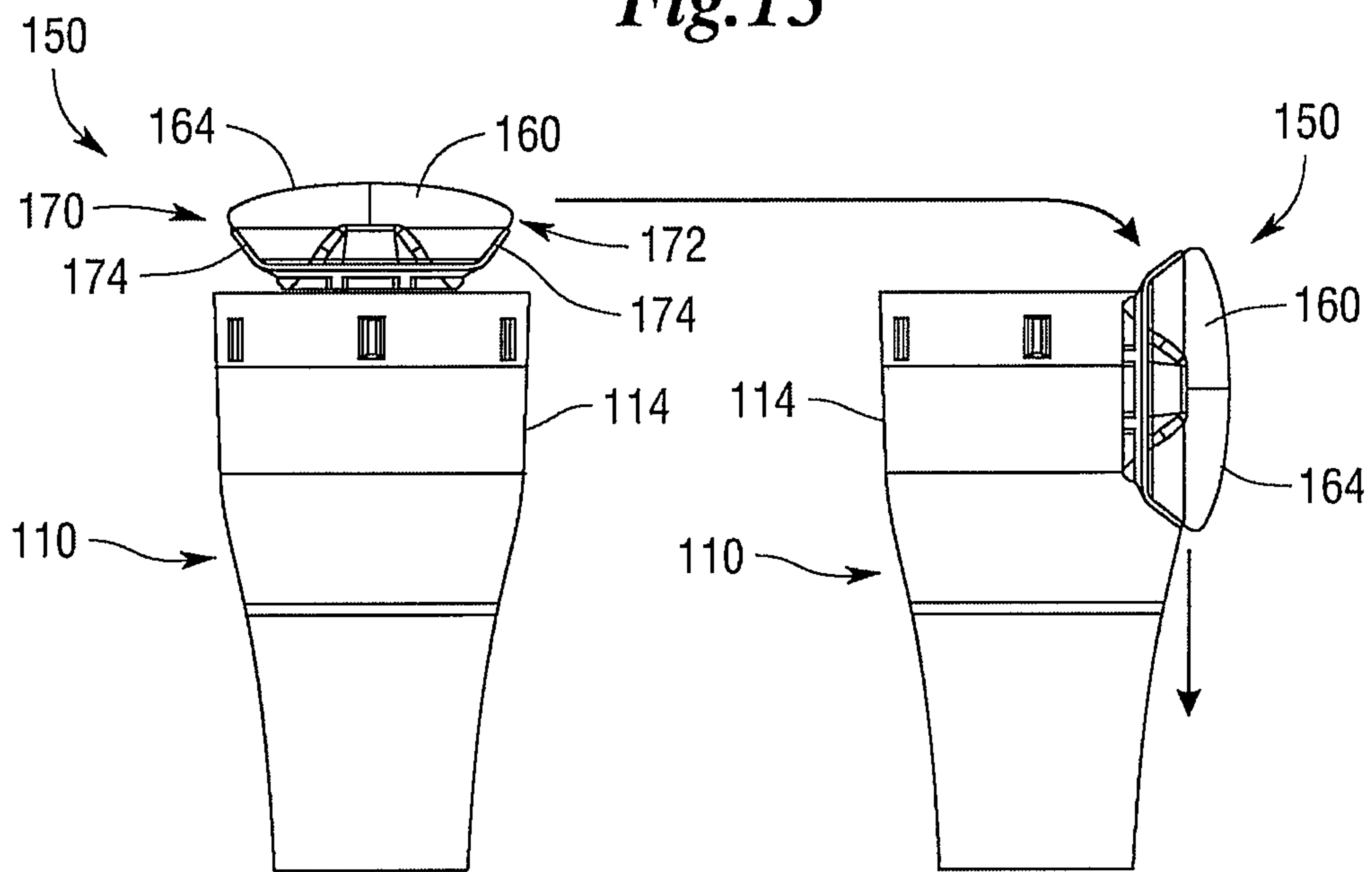

Fig. 14

Fig. 14A

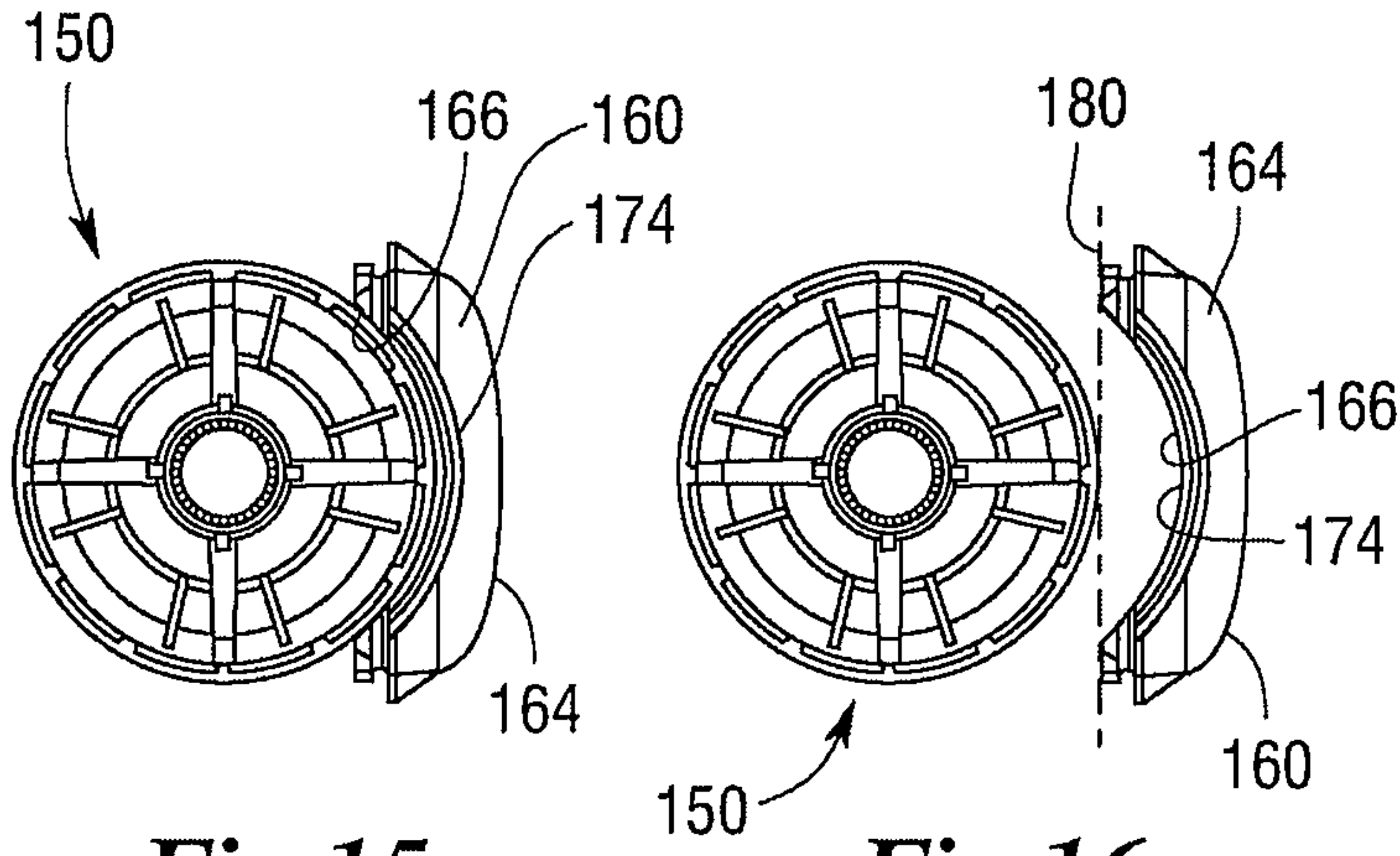

Fig. 15

Fig. 16

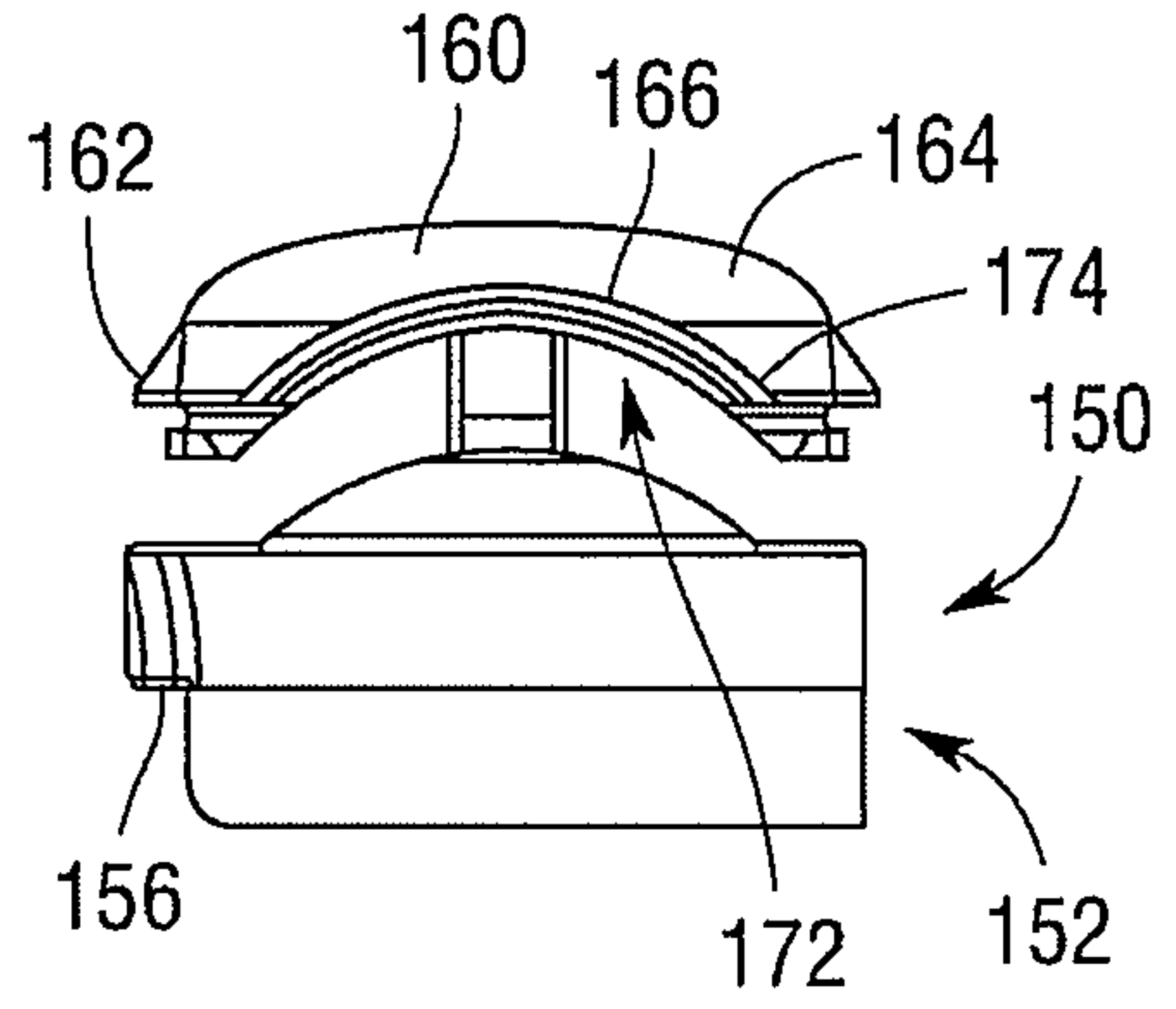

Fig. 17

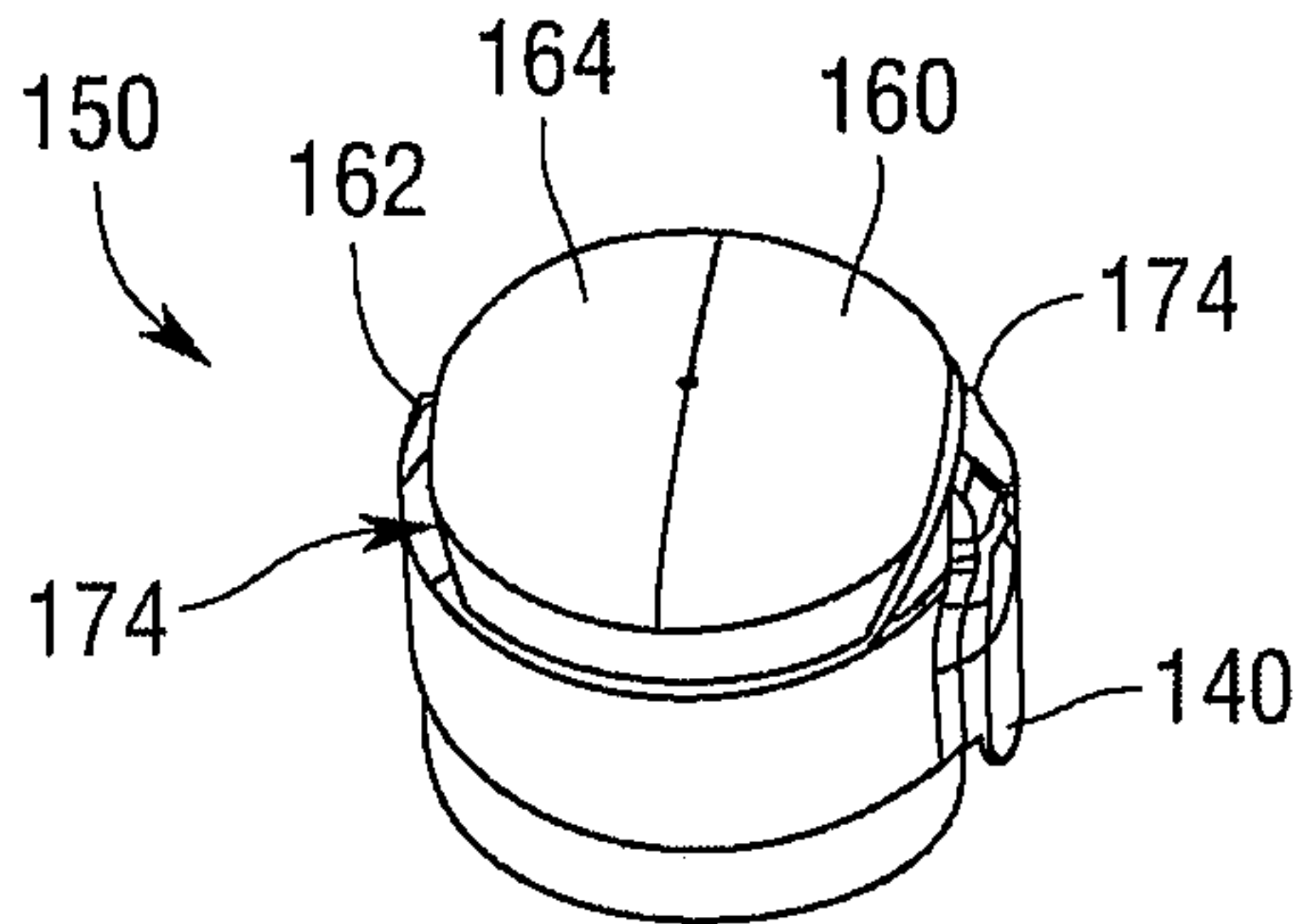

Fig. 18

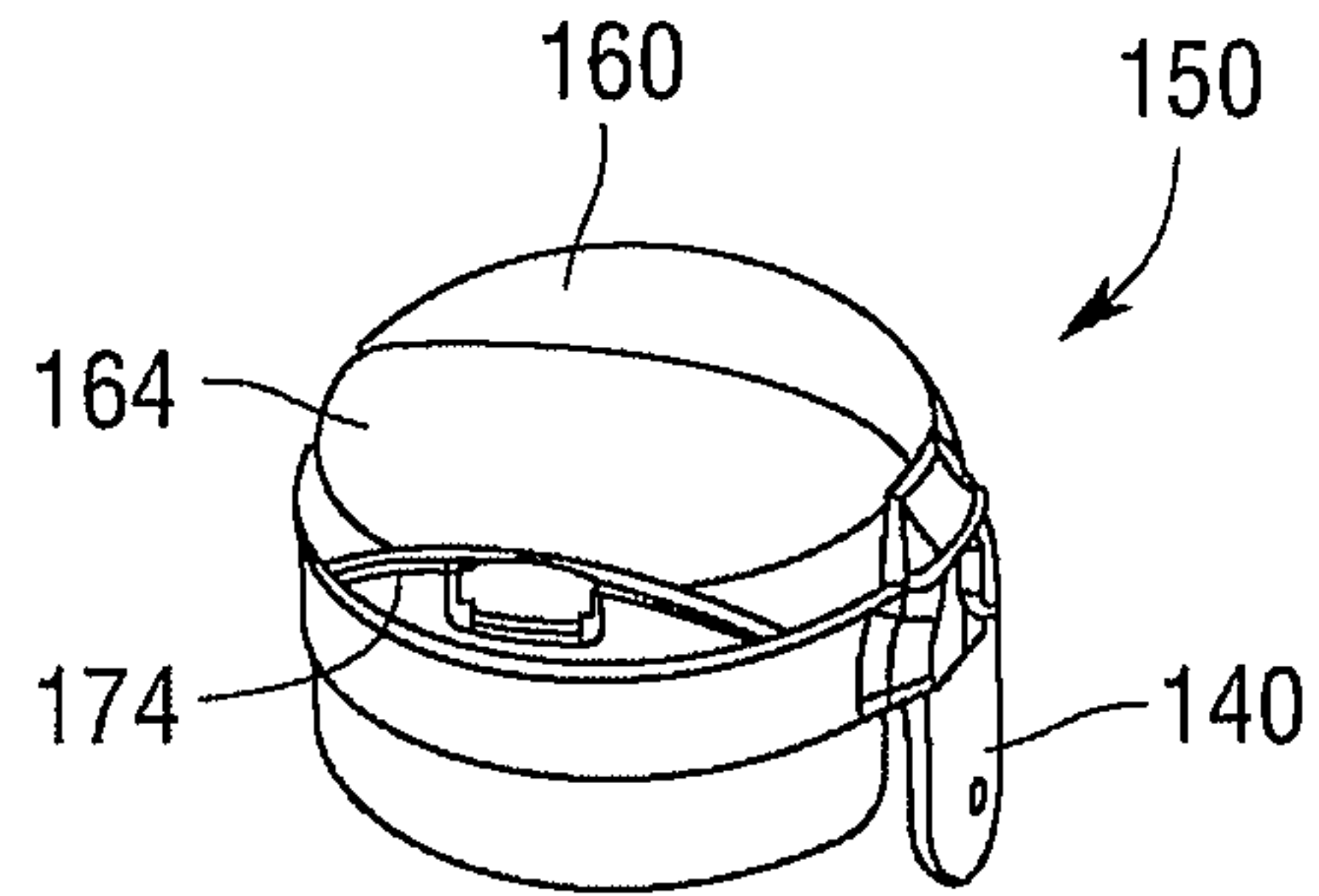

Fig. 20

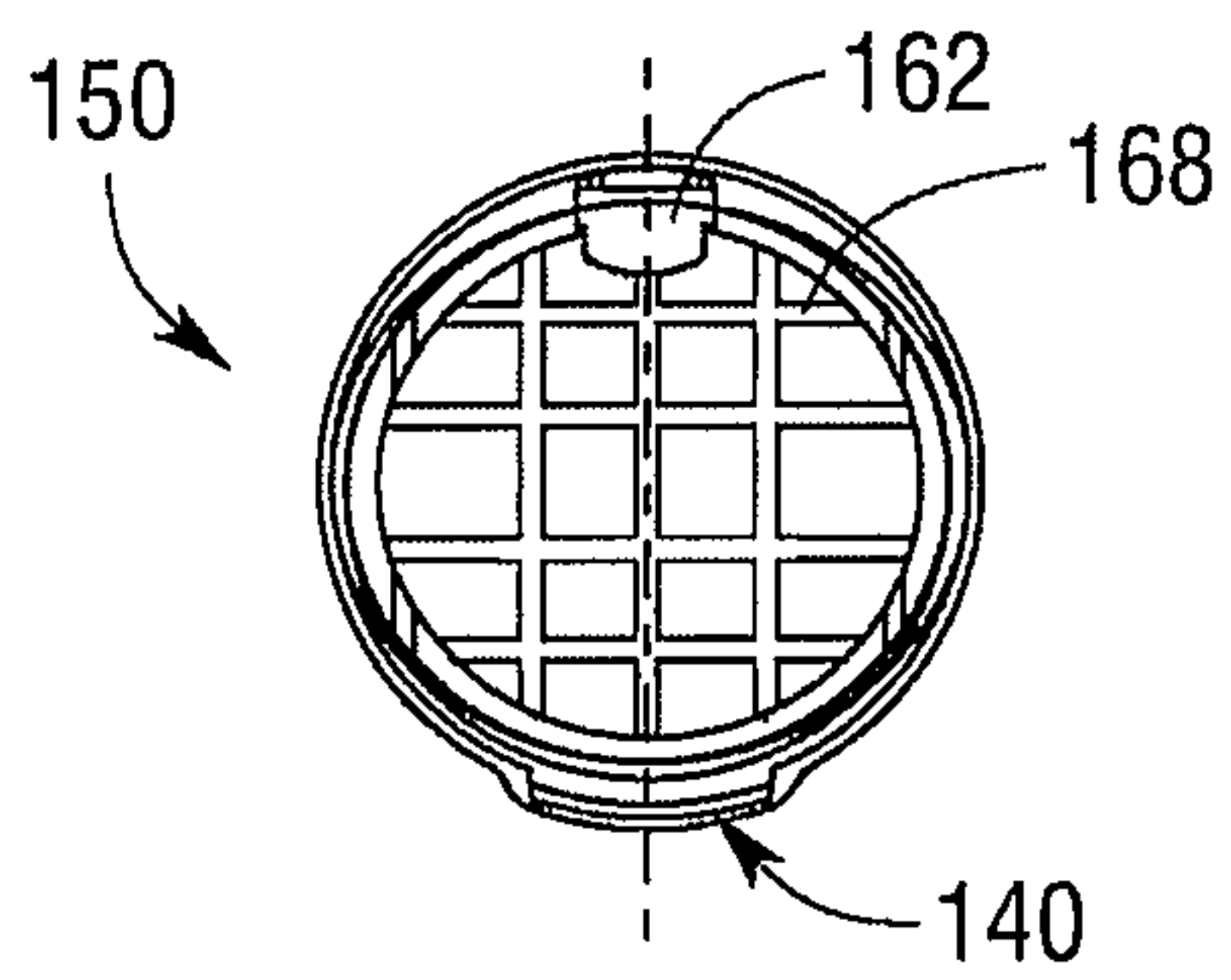

Fig. 19

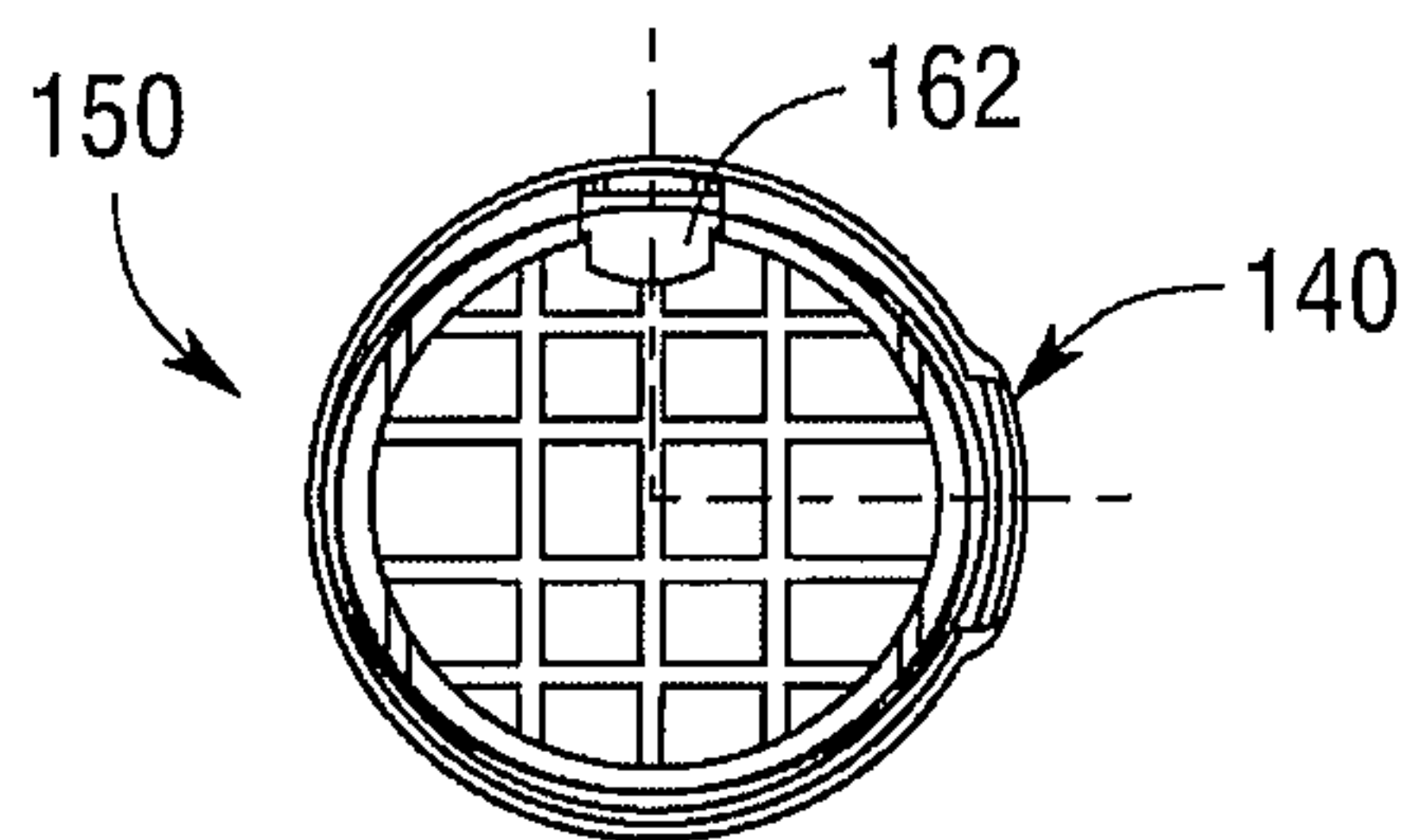

Fig. 21

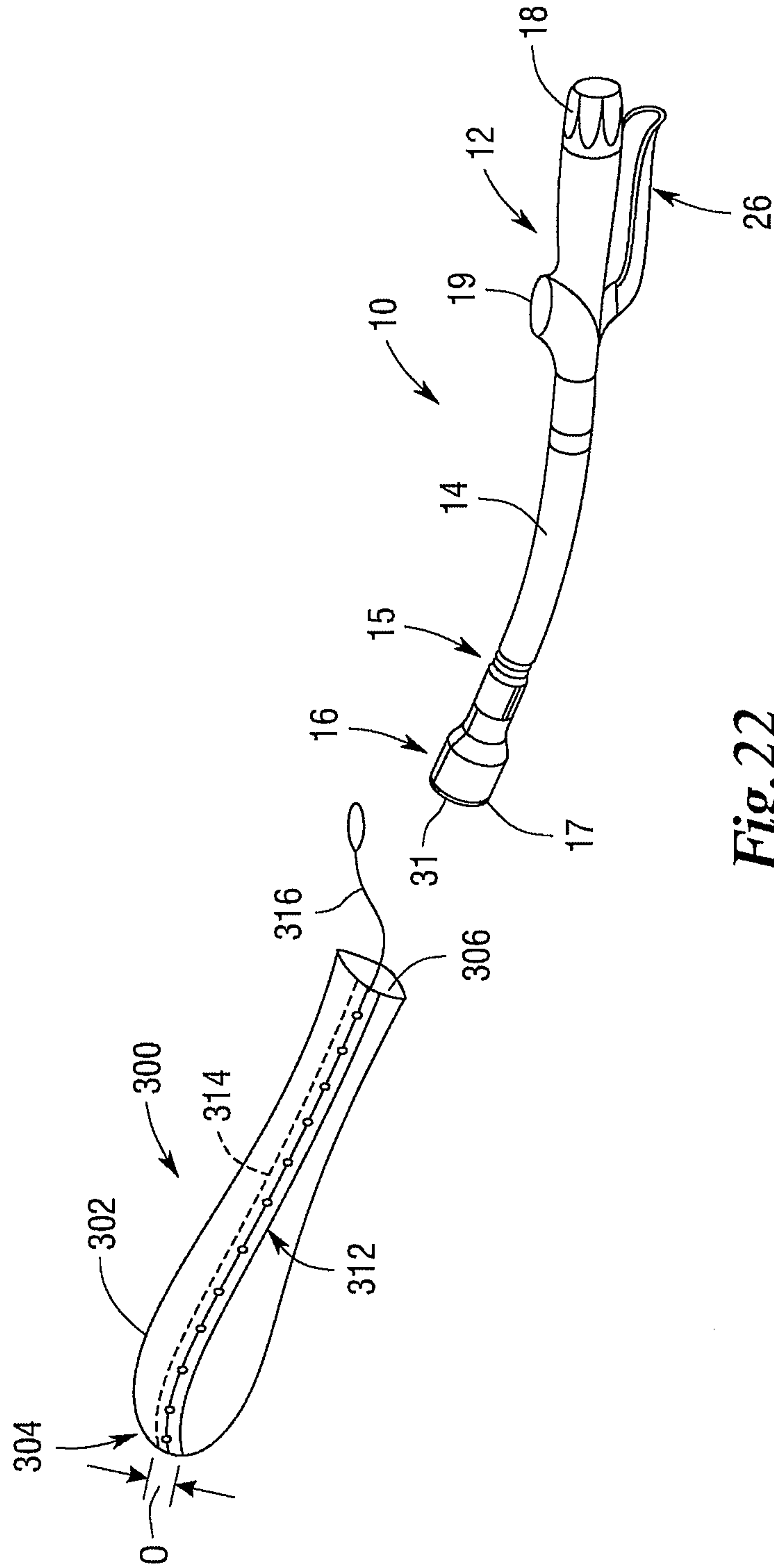

Fig. 22

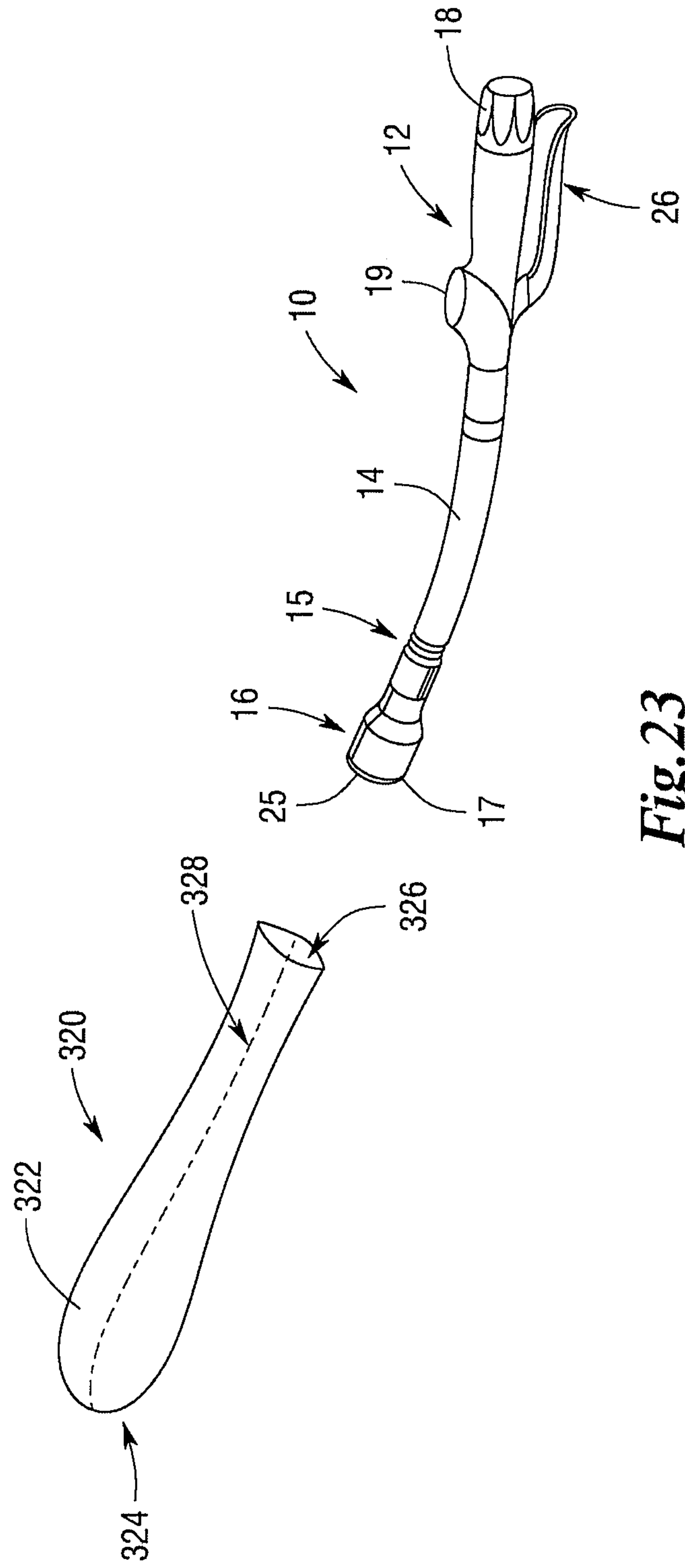

Fig. 23

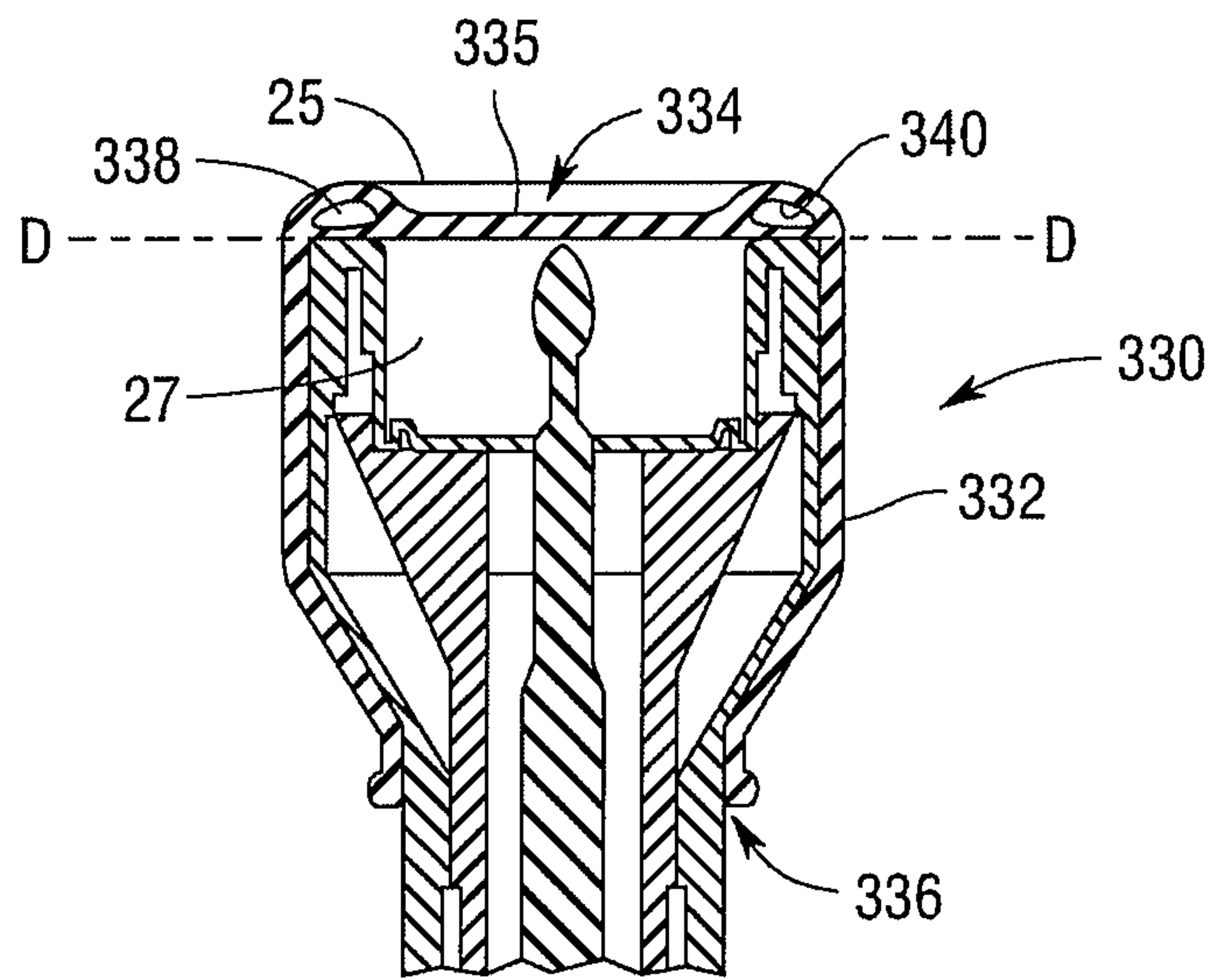
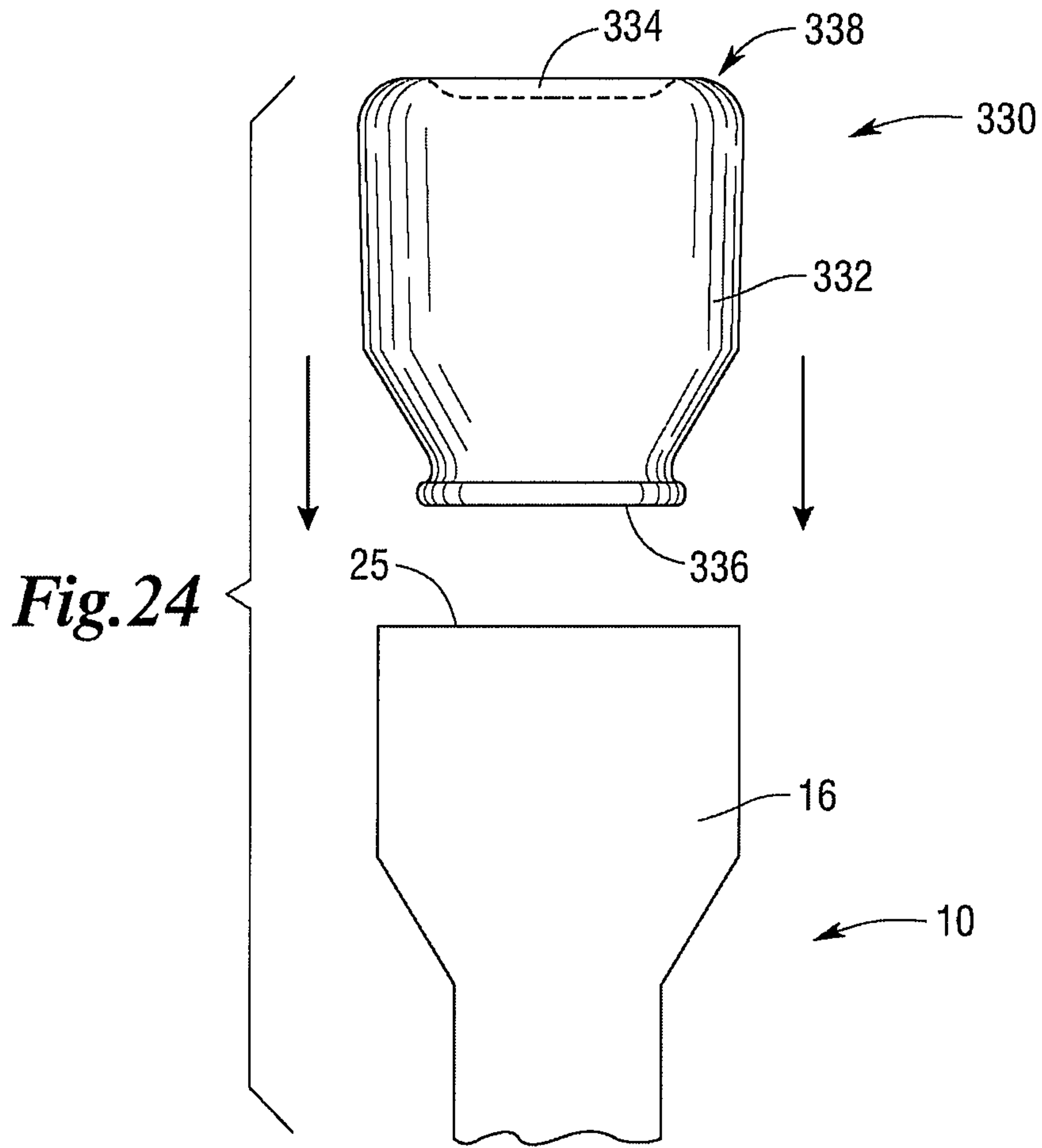

Fig. 25

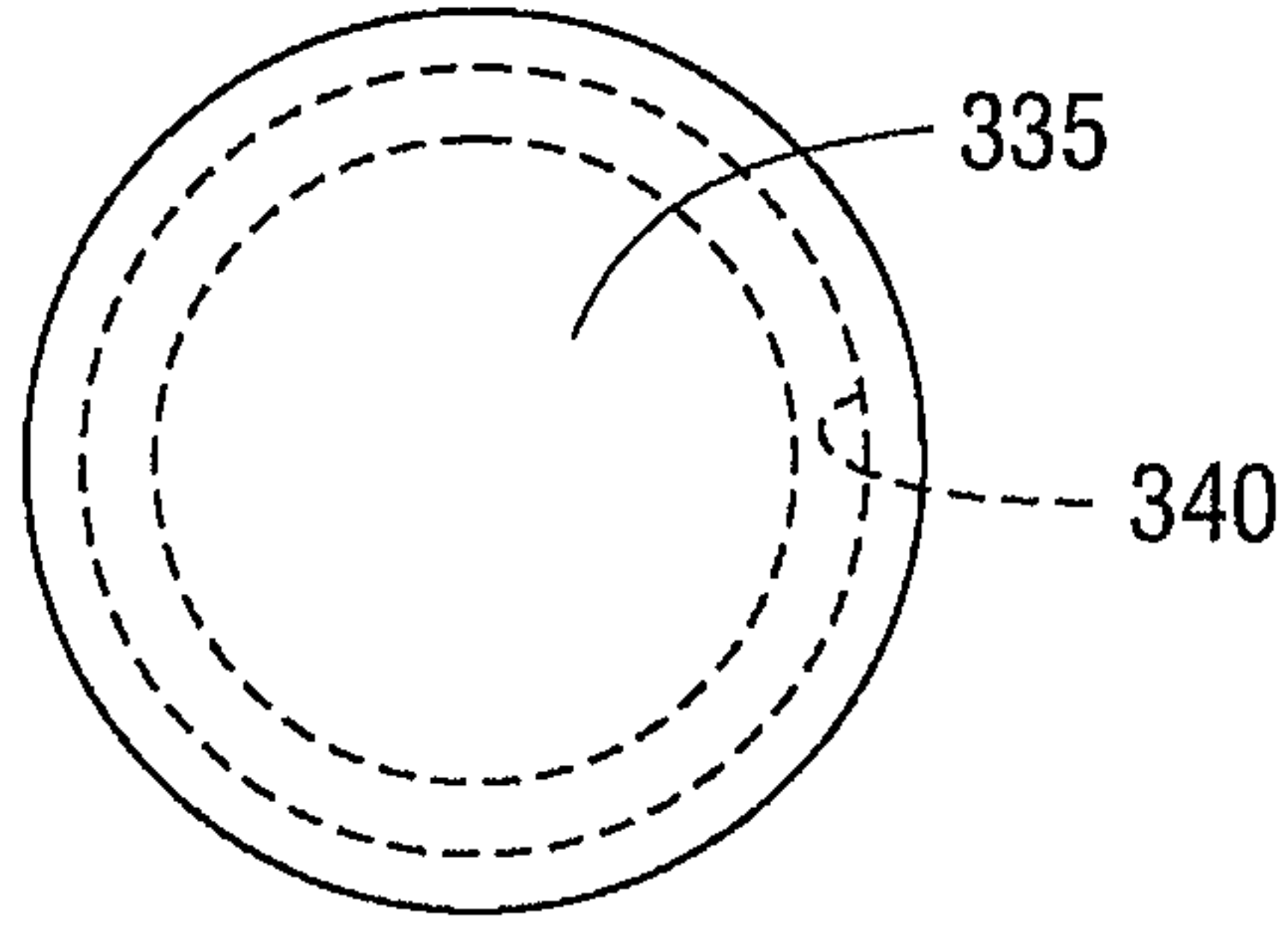

Fig. 27

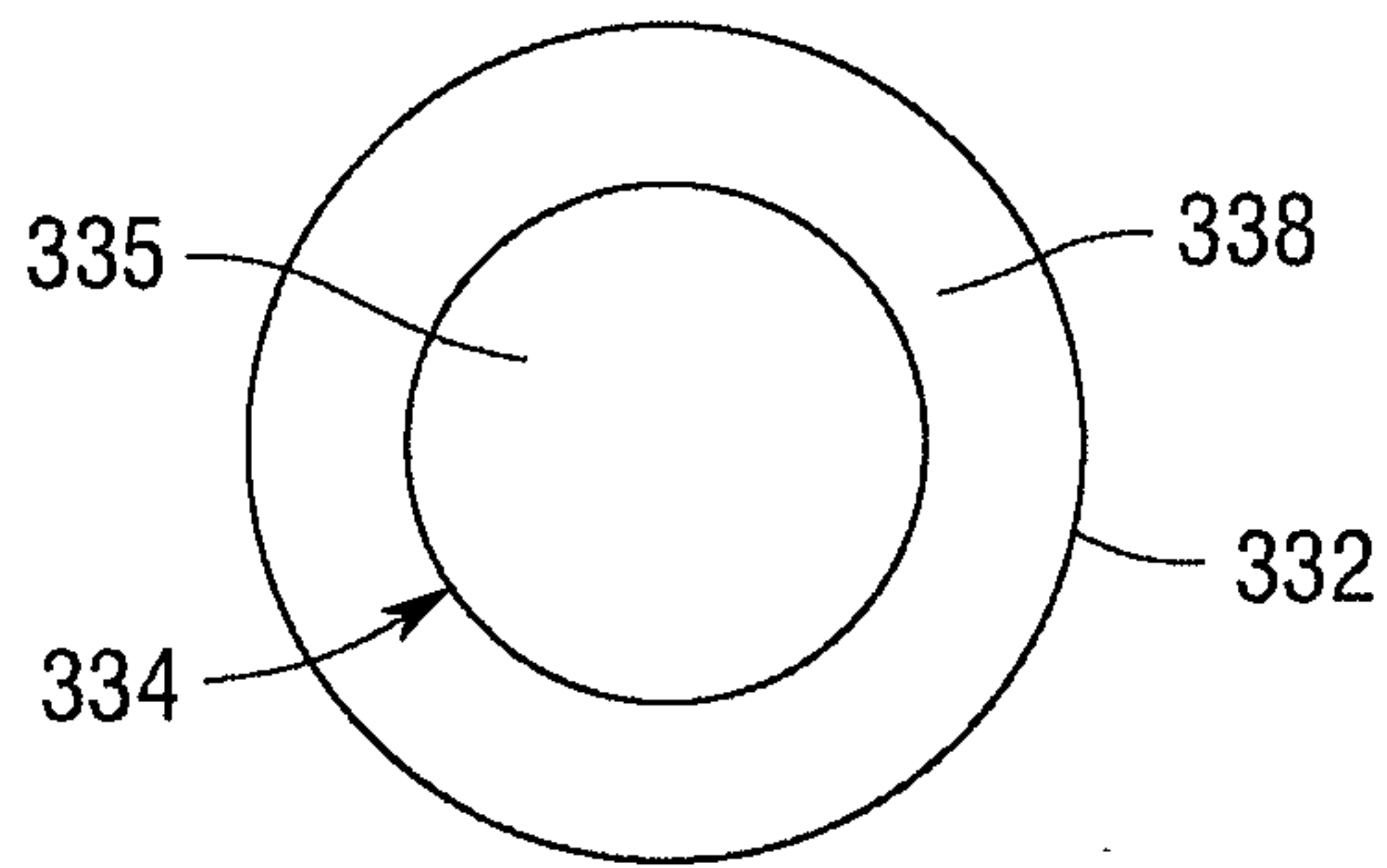

Fig. 26

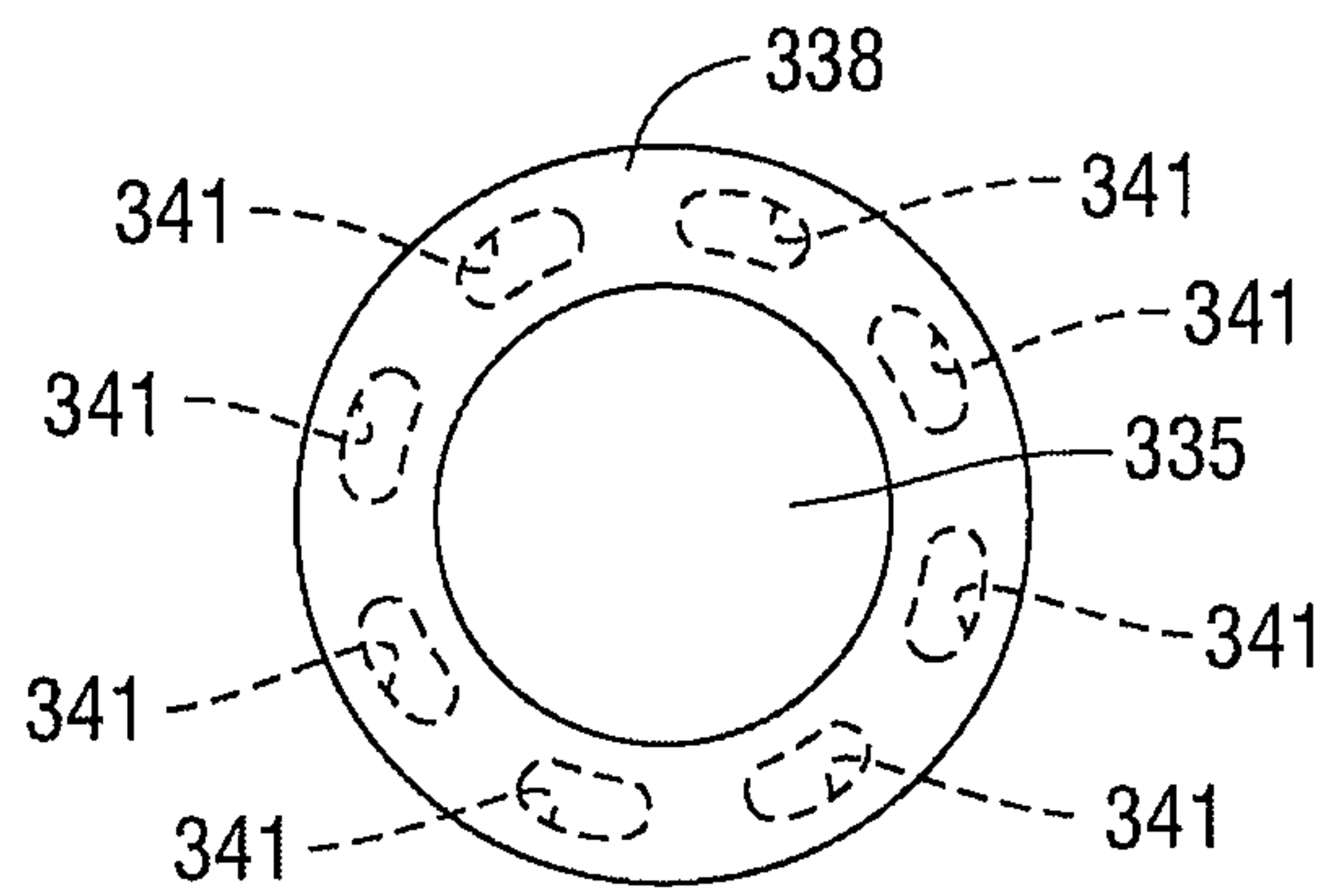

Fig. 28

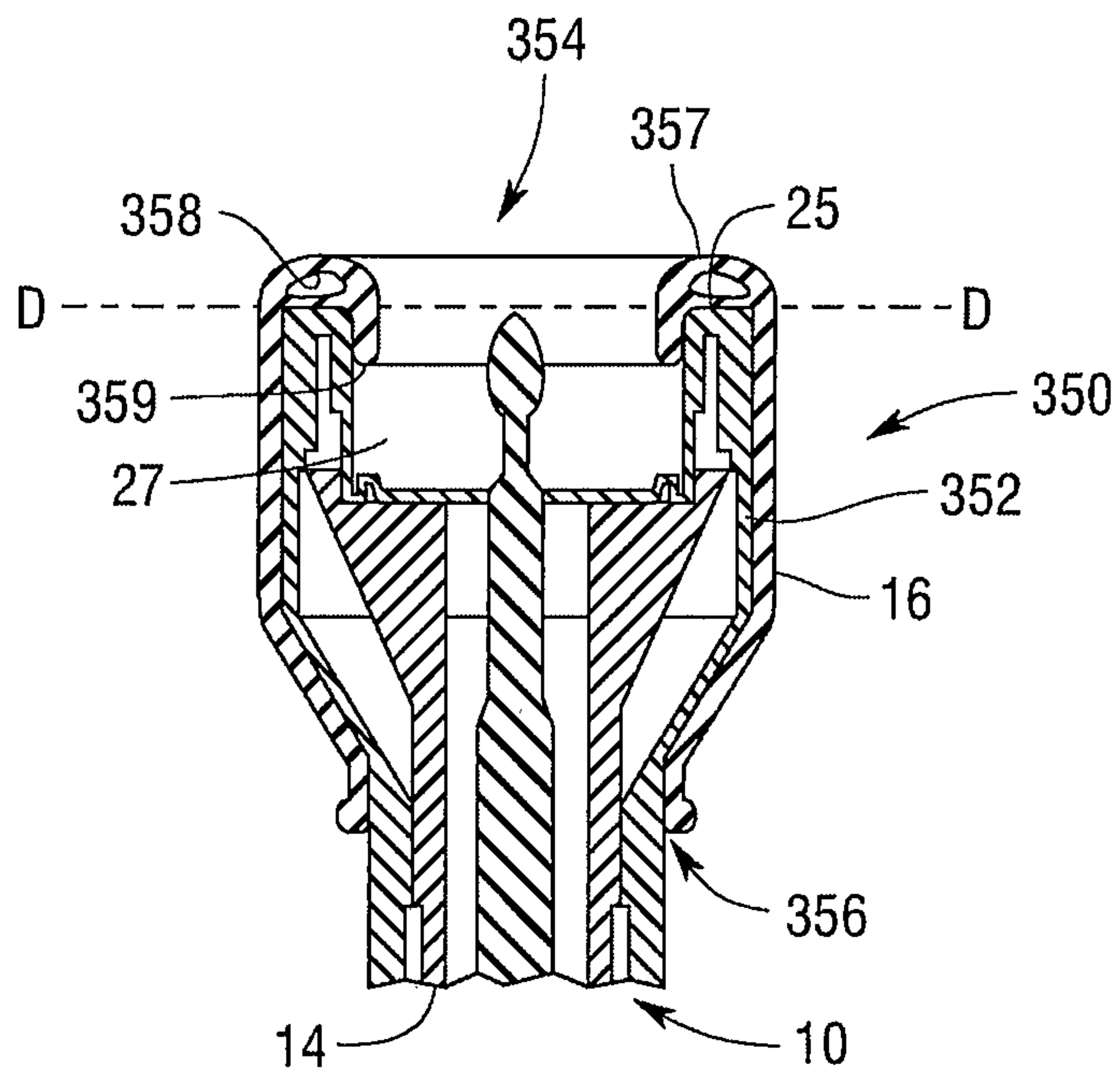

Fig. 29

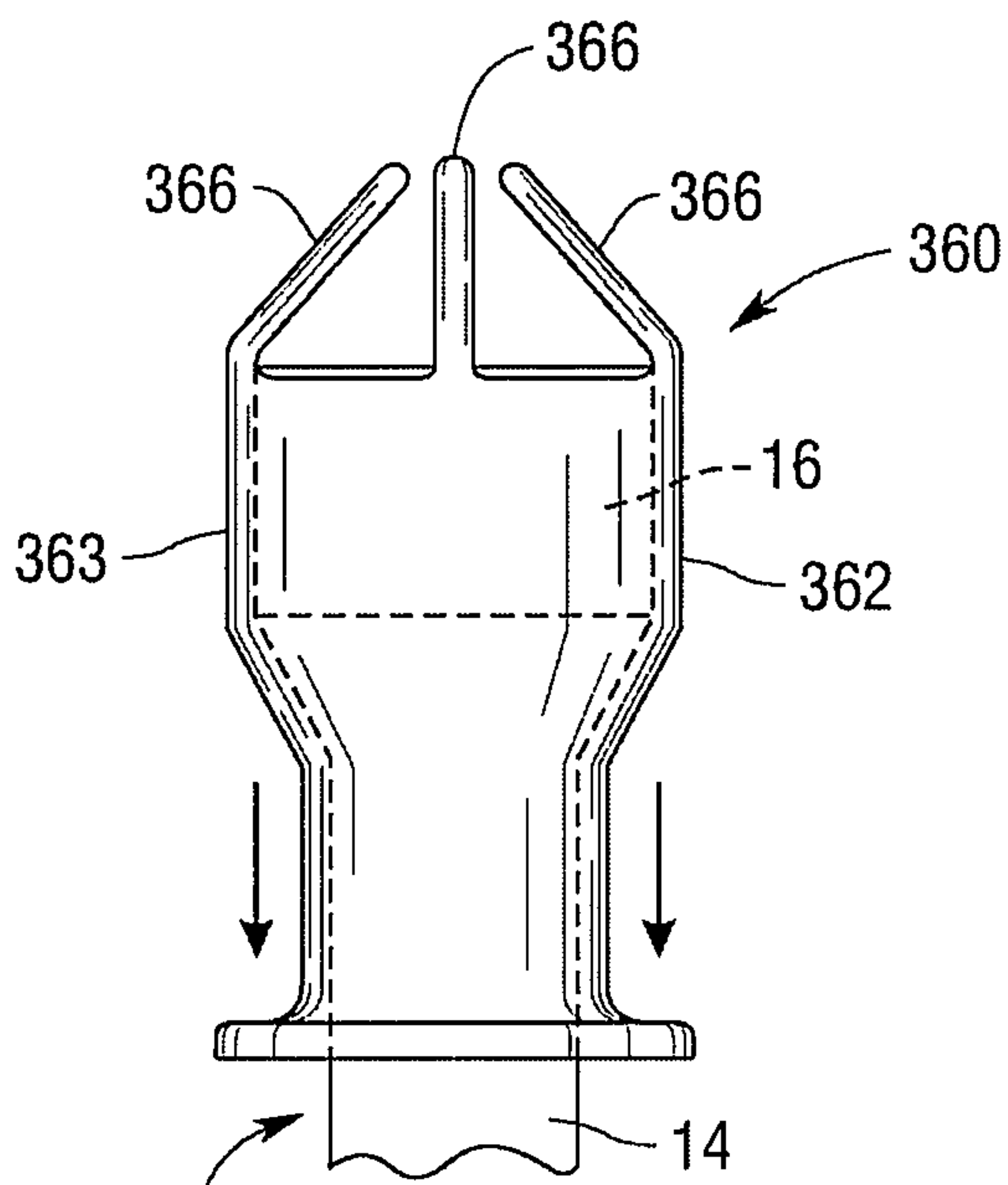

Fig.30

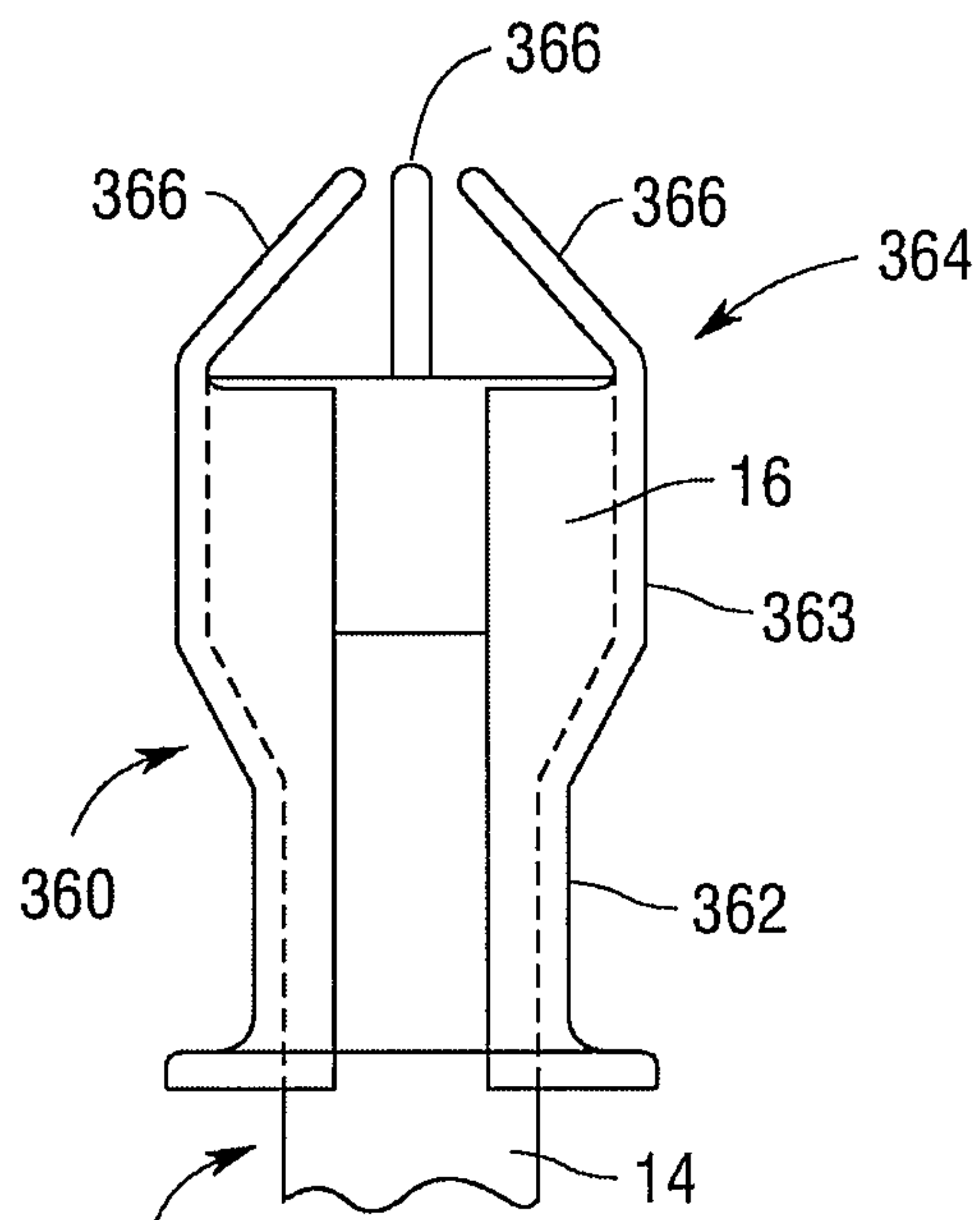

Fig.31

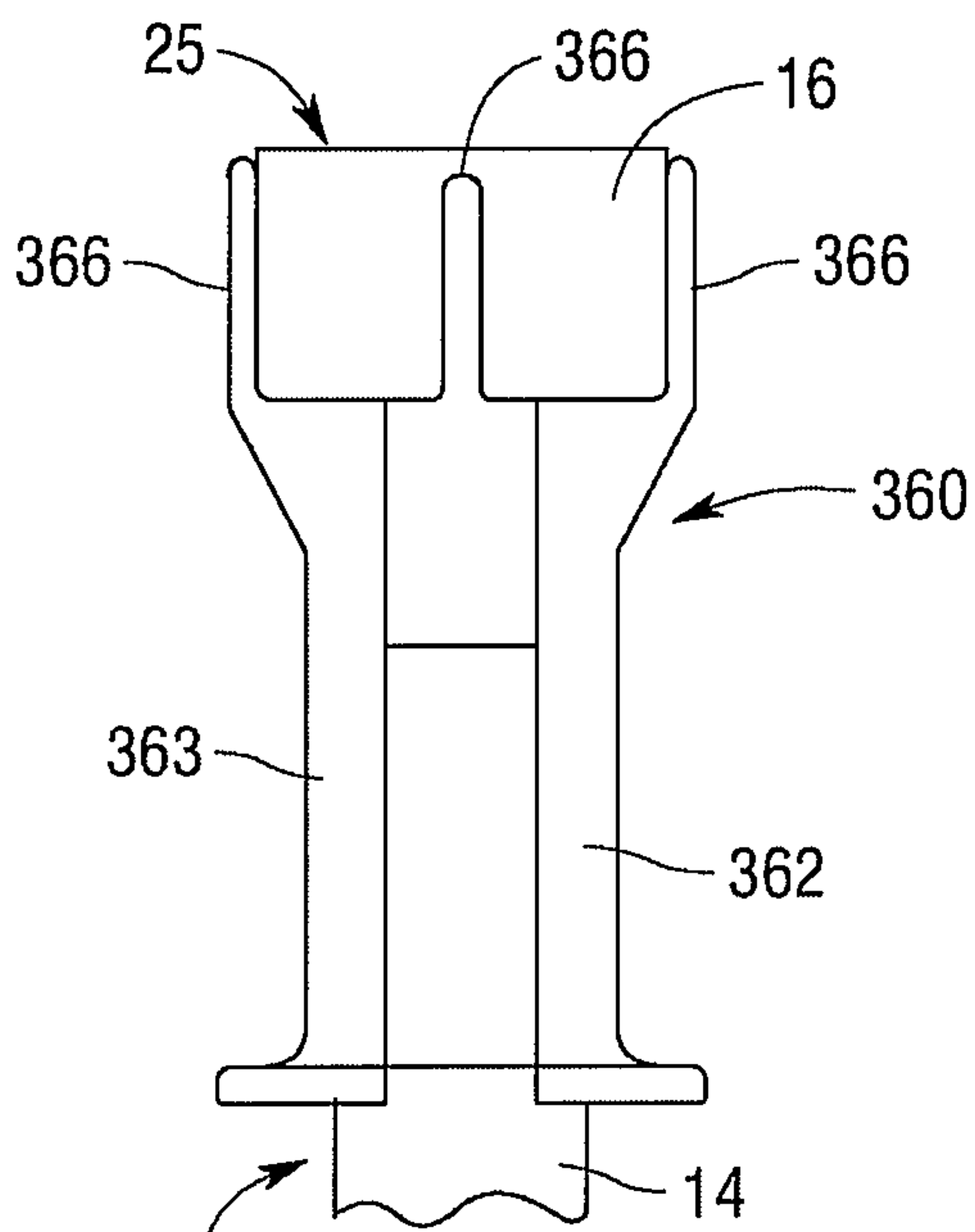

Fig.32

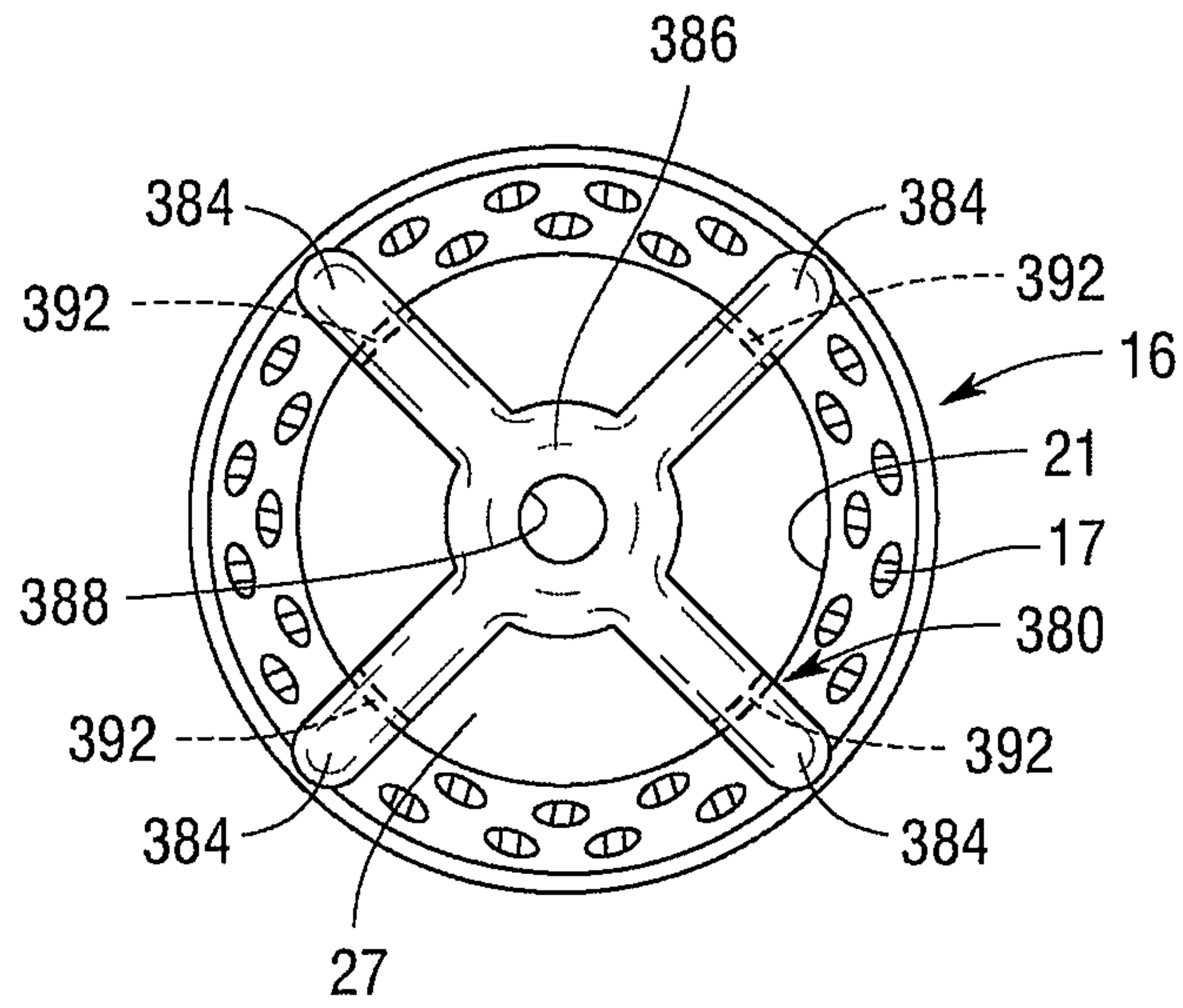

Fig. 33

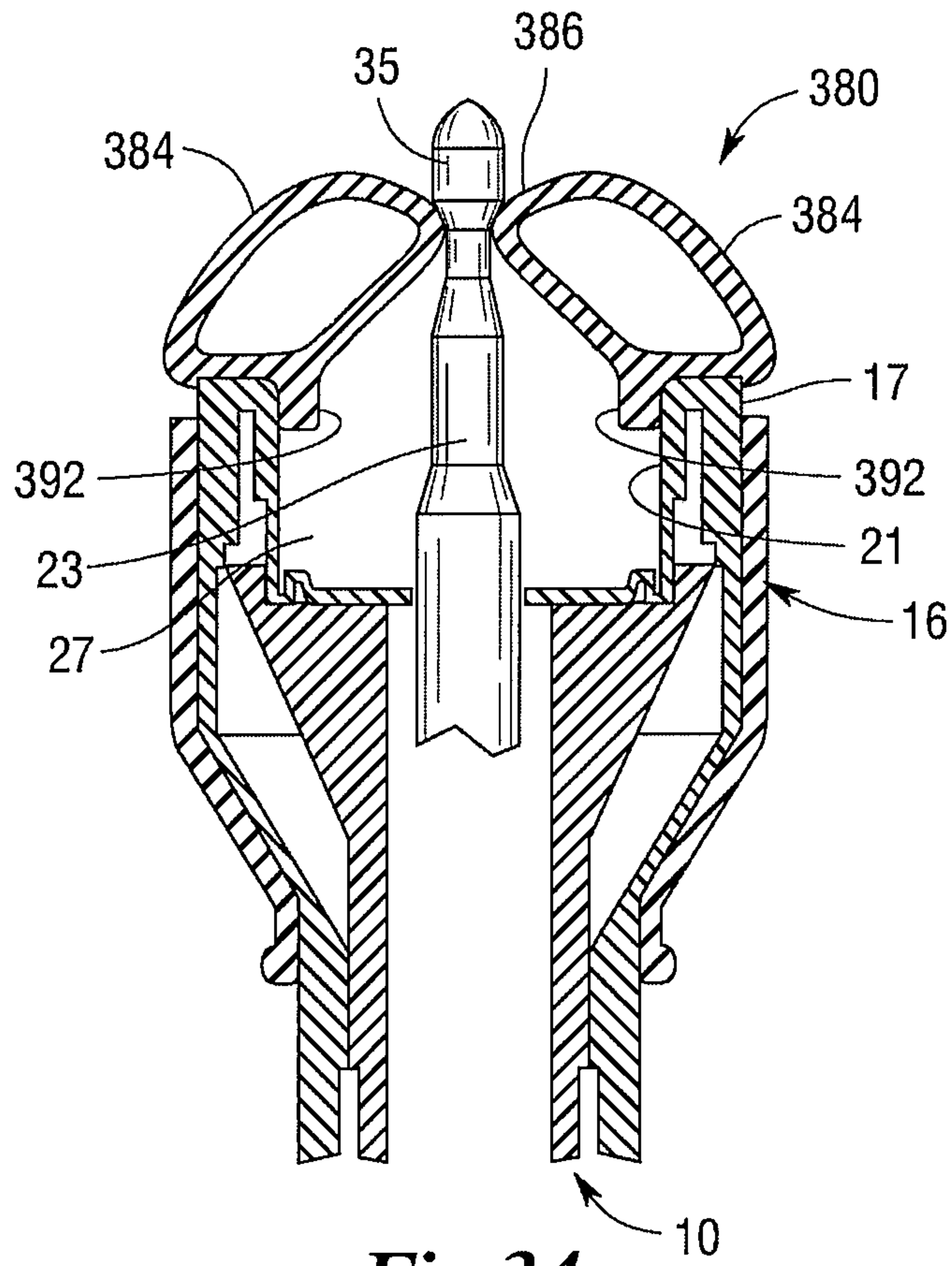

Fig. 34

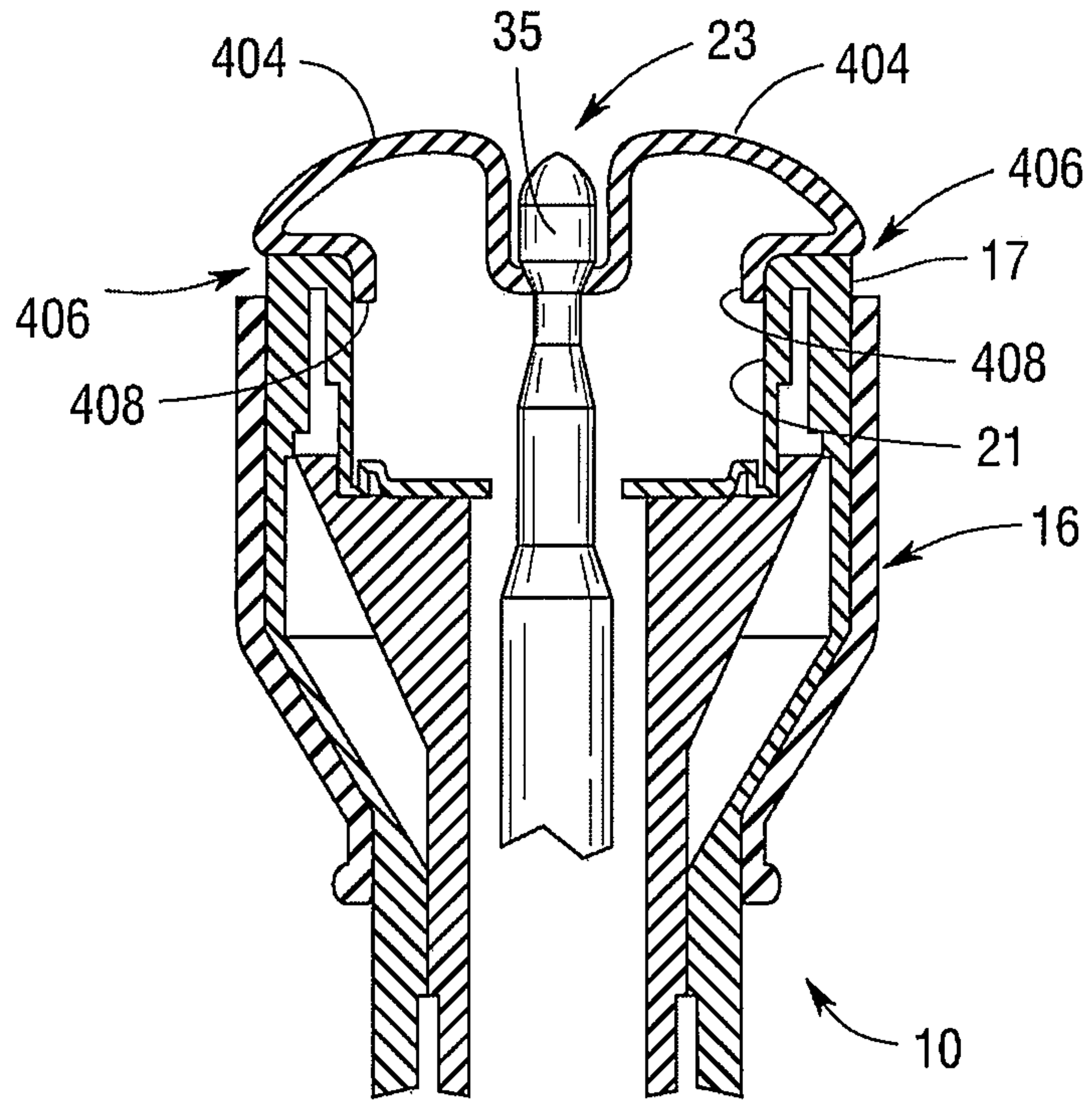

Fig.37

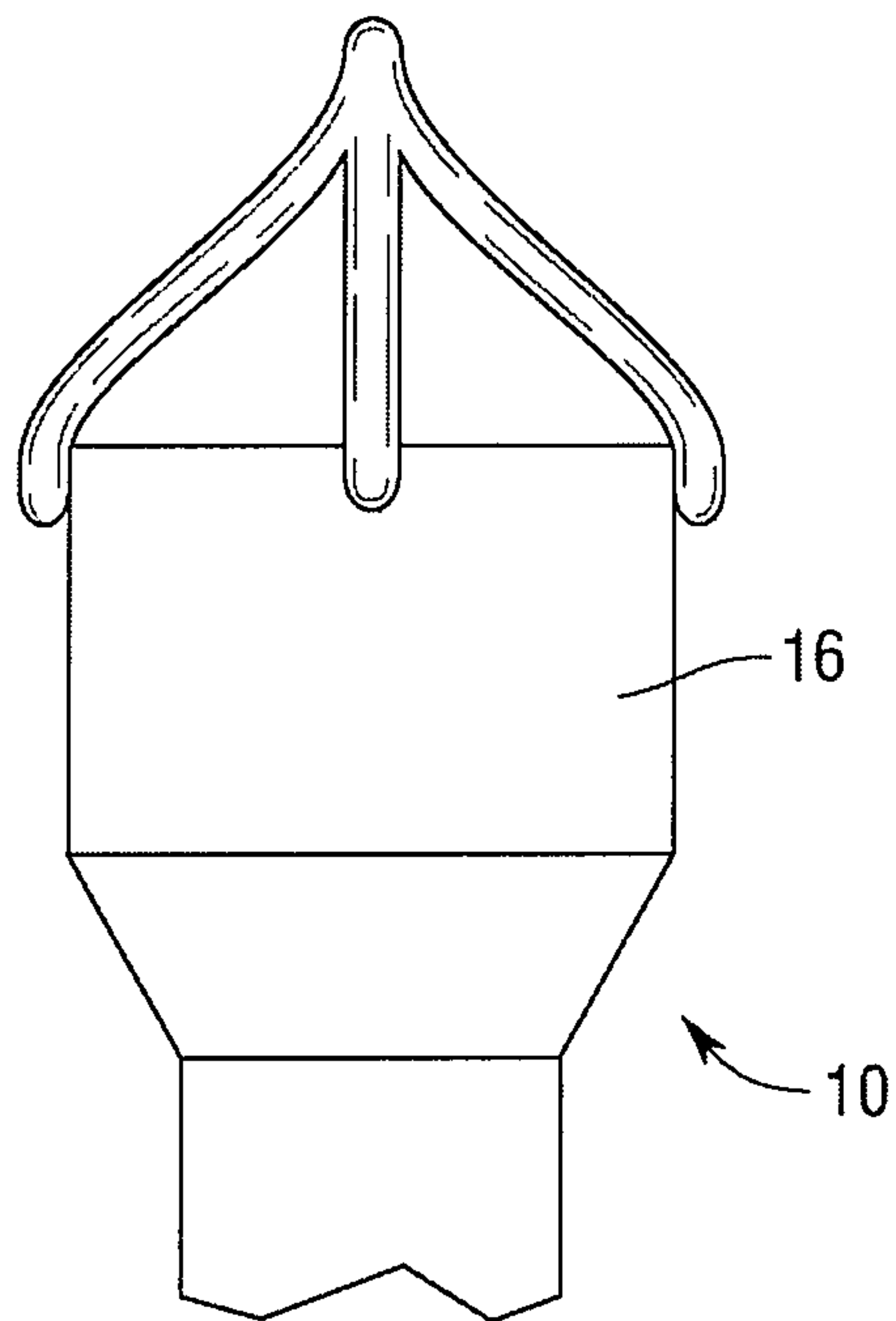

Fig.38

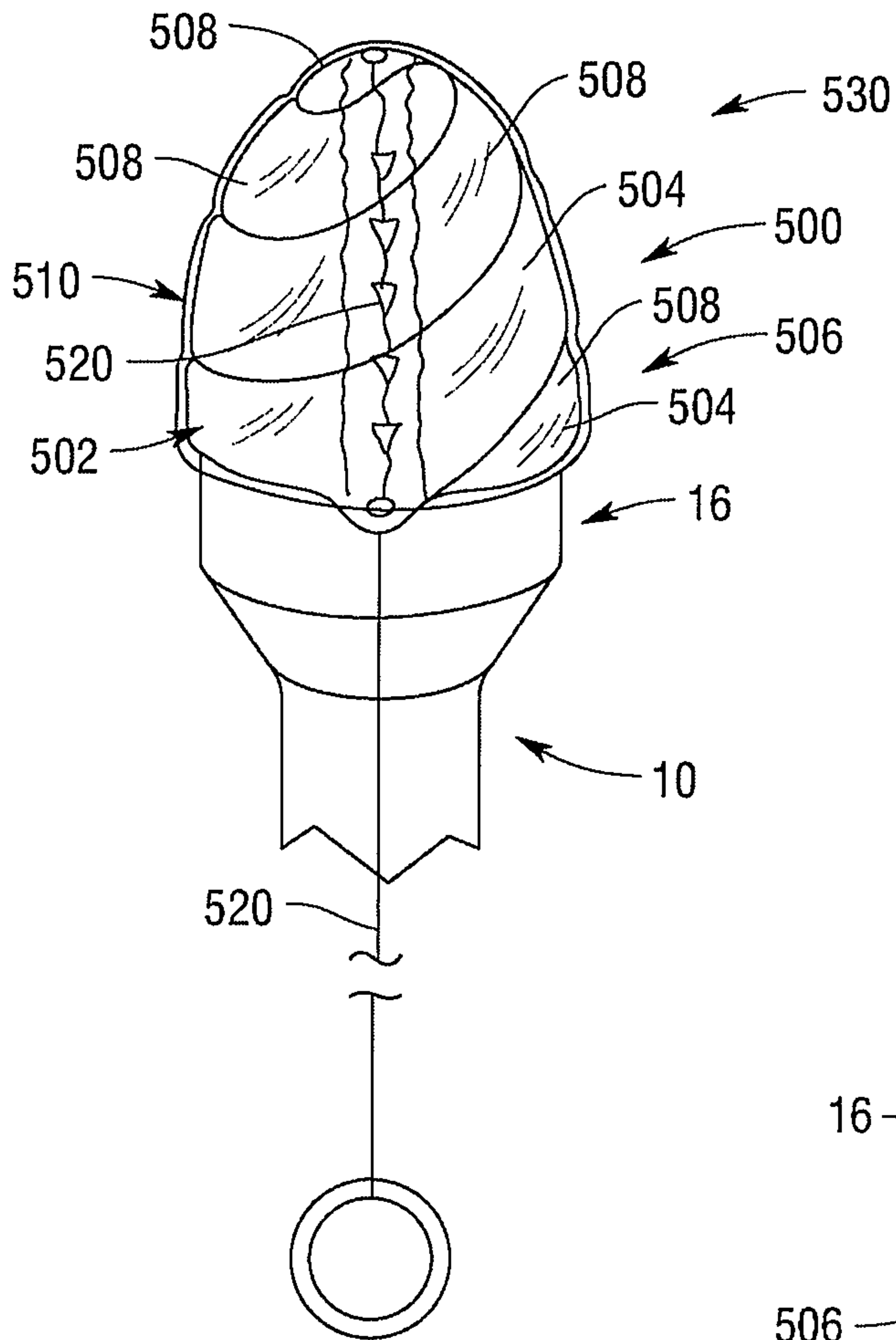

Fig. 39

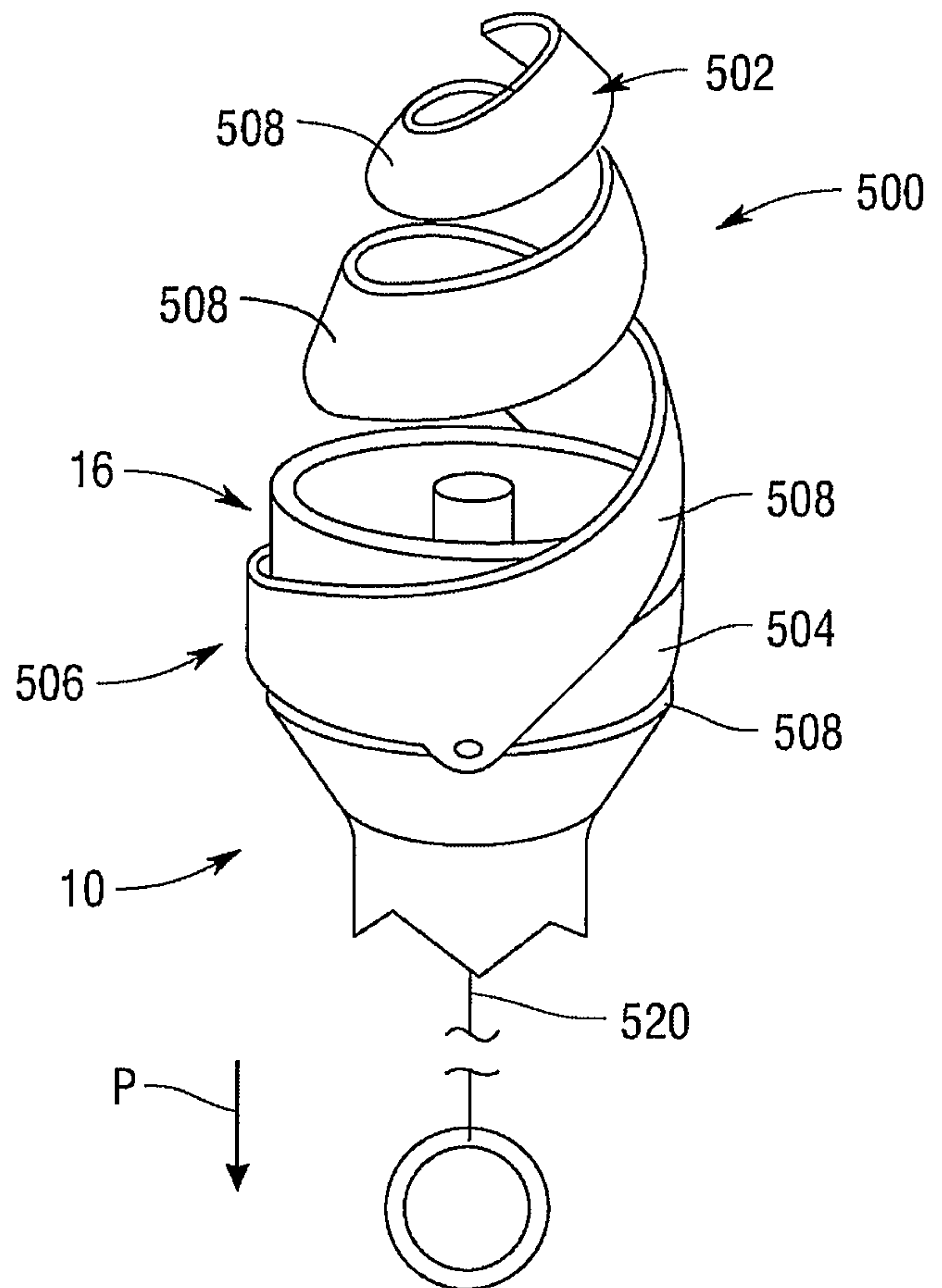

Fig. 40

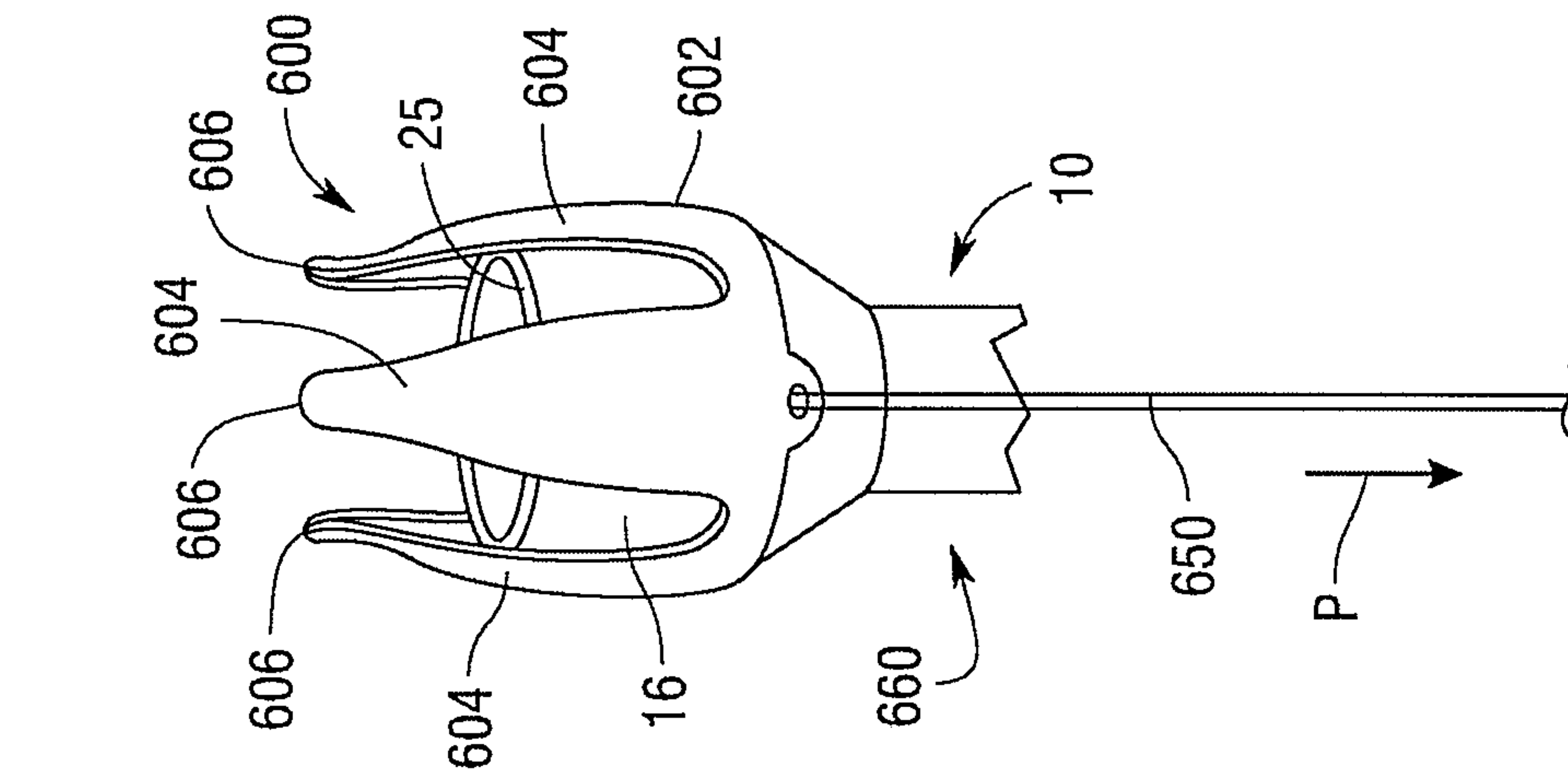

Fig. 41

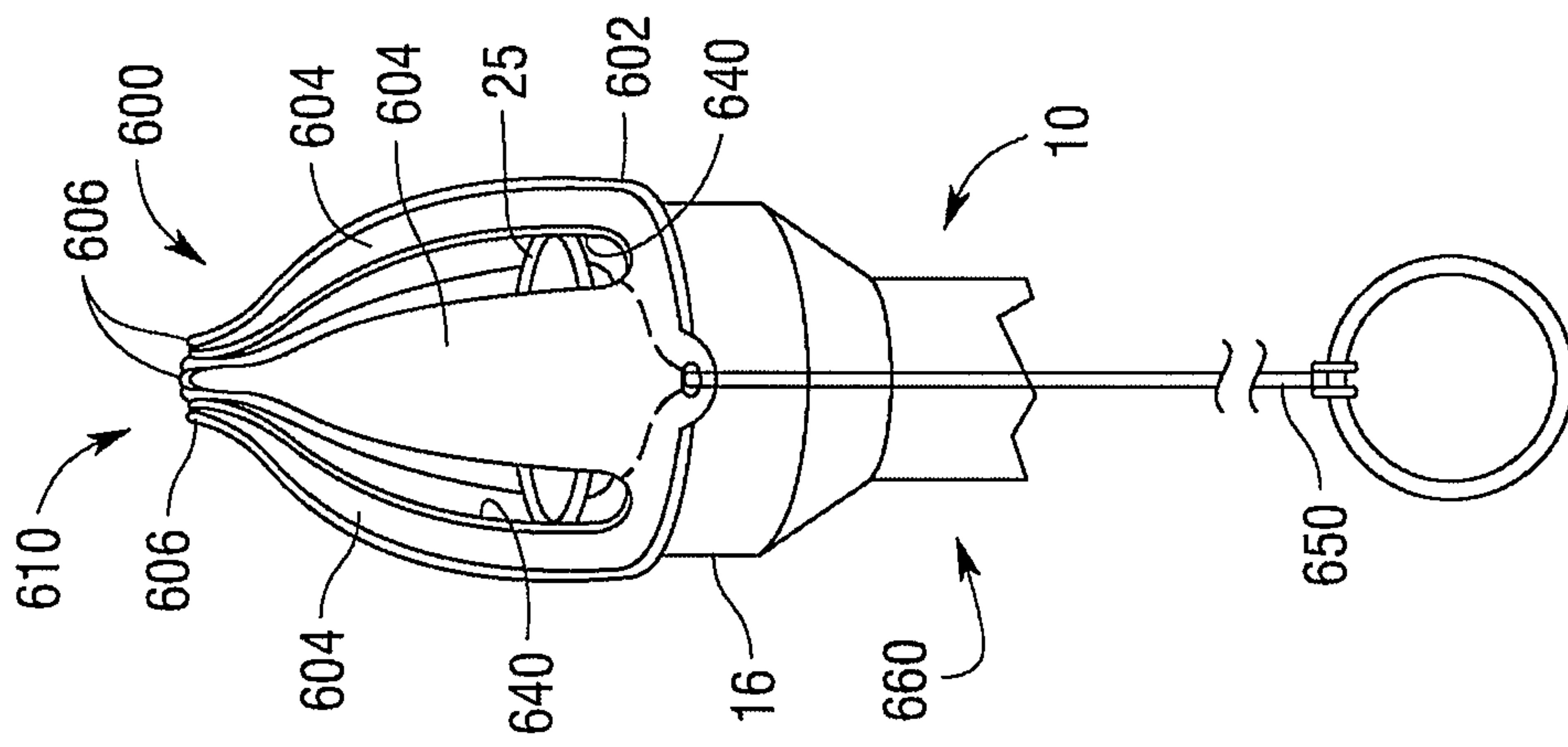

Fig. 42

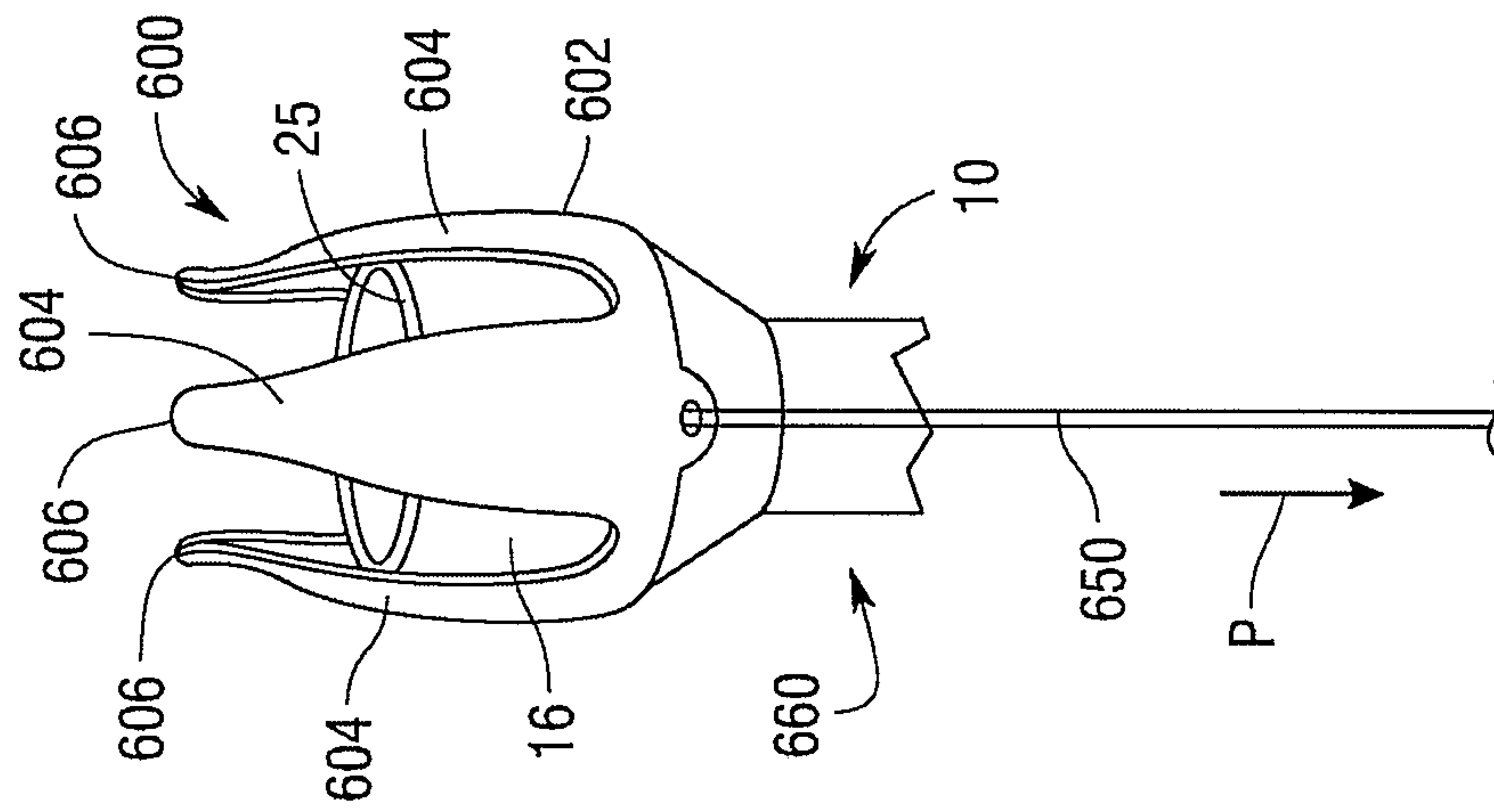

Fig. 43

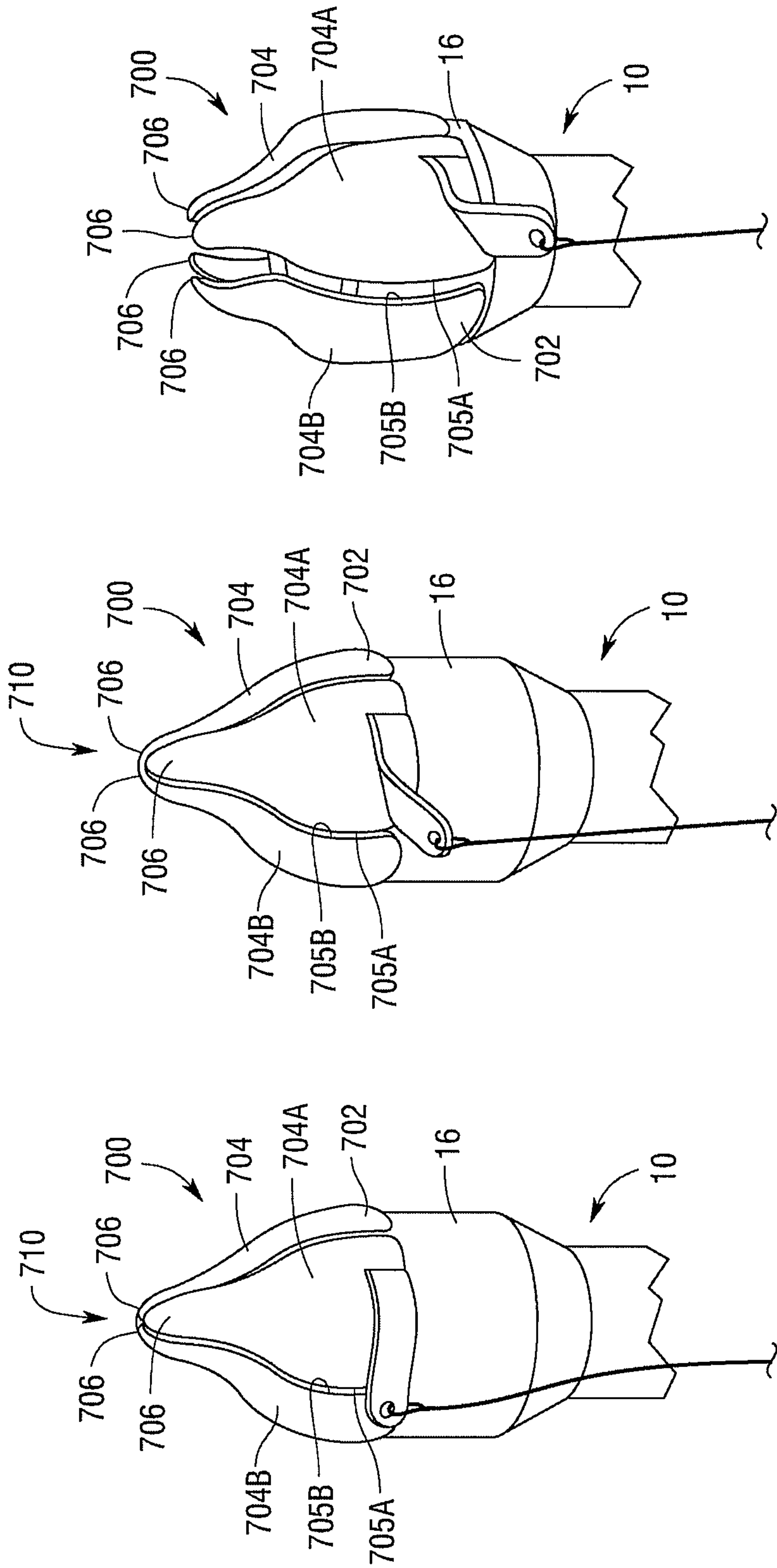

Fig. 46

Fig. 45

Fig. 44

