



- (51) International Patent Classification:
C10B 39/08 (2006.01) C10B 39/12 (2006.01)
- (21) International Application Number:
PCT/US2014/028437
- (22) International Filing Date:
14 March 2014 (14.03.2014)
- (25) Filing Language: English
- (26) Publication Language: English
- (30) Priority Data:
13/843,166 15 March 2013 (15.03.2013) US
- (71) Applicant: SUNCOKE TECHNOLOGY AND DEVELOPMENT, LLC [US/US]; 1011 Warren Road 6th Floor, Lisle, Illinois 60532 (US).
- (72) Inventors: CHOI, Chun Wai; 1011 Warrenville Road 6th Floor, Lisle, Illinois 60532 (US). KAPOOR, Rajat; 1011 Warrenville Road 6th Floor, Lisle, Illinois 60532 (US). QUANCI, John Francis; 1011 Warrenville Road 6th Floor, Lisle, Illinois 60532 (US).

(74) Agents: BETCHER, Susan D. et al.; Perkins Coie LLP, P O Box 1247, Seattle, Washington 98111-1247 (US).

(81) Designated States (unless otherwise indicated, for every kind of national protection available): AE, AG, AL, AM, AO, AT, AU, AZ, BA, BB, BG, BH, BN, BR, BW, BY, BZ, CA, CH, CL, CN, CO, CR, CU, CZ, DE, DK, DM, DO, DZ, EC, EE, EG, ES, FI, GB, GD, GE, GH, GM, GT, HN, HR, HU, ID, IL, IN, IR, IS, JP, KE, KG, KN, KP, KR, KZ, LA, LC, LK, LR, LS, LT, LU, LY, MA, MD, ME, MG, MK, MN, MW, MX, MY, MZ, NA, NG, NI, NO, NZ, OM, PA, PE, PG, PH, PL, PT, QA, RO, RS, RU, RW, SA, SC, SD, SE, SG, SK, SL, SM, ST, SV, SY, TH, TJ, TM, TN, TR, TT, TZ, UA, UG, US, UZ, VC, VN, ZA, ZM, ZW.

(84) Designated States (unless otherwise indicated, for every kind of regional protection available): ARIPO (BW, GH, GM, KE, LR, LS, MW, MZ, NA, RW, SD, SL, SZ, TZ, UG, ZM, ZW), Eurasian (AM, AZ, BY, KG, KZ, RU, TJ, TM), European (AL, AT, BE, BG, CH, CY, CZ, DE, DK, EE, ES, FI, FR, GB, GR, HR, HU, IE, IS, IT, LT, LU, LV, MC, MK, MT, NL, NO, PL, PT, RO, RS, SE, SI, SK, SM,

[Continued on next page]

(54) Title: METHODS AND SYSTEMS FOR IMPROVED QUENCH TOWER DESIGN

(57) Abstract: The present technology describes methods and systems for an improved quench tower. Some embodiments improve the quench tower's ability to recover particulate matter, steam, and emissions that escape from the base of the quench tower. Some embodiments improve the draft and draft distribution of the quench tower. Some embodiments include one or more sheds to enlarge the physical or effective perimeter of the quench tower to reduce the amount of particulate matter, emissions, and steam loss during the quenching process. Some embodiments include an improved quench baffle formed of a plurality of single-turn or multi-turn chevrons adapted to prevent particulate matter from escaping the quench tower. Some embodiments include an improved quench baffle spray nozzle used to wet the baffles, suppress dust, and/or clean baffles. Some embodiments include a quench nozzle that can fire in discrete stages during the quenching process.

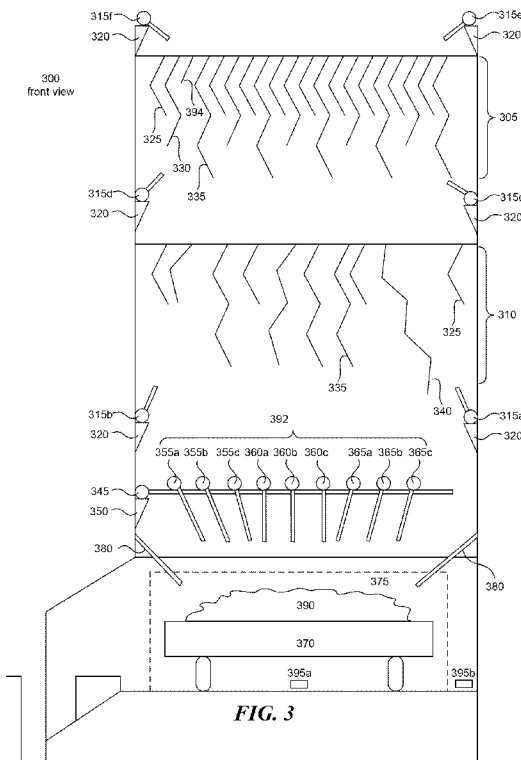

FIG. 3

WO 2014/144149 A1

TR), OAPI (BF, BJ, CF, CG, CI, CM, GA, GN, GQ, GW, —
KM, ML, MR, NE, SN, TD, TG).

*before the expiration of the time limit for amending the
claims and to be republished in the event of receipt of
amendments (Rule 48.2(h))*

Published:

— *with international search report (Art. 21(3))*

METHODS AND SYSTEMS FOR IMPROVED QUENCH TOWER
DESIGN

CROSS-REFERENCE TO RELATED APPLICATIONS

[0001] This application claims the benefit of priority to U.S. Non-Provisional Patent Application No. 13/843,166, filed March 15, 2013, the disclosure of which is incorporated herein by reference in its entirety.

TECHNICAL FIELD

[0002] The present technology is generally directed to methods and systems for an improved quench tower. More specifically, the various embodiments herein are directed to an improved quench tower design and arrangement that includes one or more sheds attached to the quench tower, a dust suppression system, a baffle design formed of chevrons having multiple turns, and an automated quenching procedure.

BACKGROUND

[0003] Coke is a solid carbon fuel and carbon source used to melt and reduce iron ore in the production of steel. In one process, known as the "Thompson Coking Process," coke is produced by batch feeding pulverized coal to an oven that is sealed and heated to very high temperatures for 24 to 48 hours under closely-controlled atmospheric conditions. Coking ovens have been used for many years to convert coal into metallurgical coke. During the coking process, finely crushed coal is heated under controlled temperature conditions to devolatilize the coal and form a fused mass of coke having a predetermined porosity and strength. Because the production of coke is a batch process, multiple coke ovens are operated simultaneously.

[0004] Coal particles or a blend of coal particles are charged into hot ovens, and the coal is heated in the ovens in order to remove volatile matter ("VM") from the resulting coke. The coking process is highly dependent on the oven design, the type of coal, and conversion temperature used. Typically, ovens are adjusted during the

coking process so that each charge of coal is coked out in approximately the same amount of time. Once the coal is fully coked out, the resulting coke may take the form of a substantially intact coke loaf that is then quenched with water or another liquid. Because the coke loaf may stay intact during quenching, the quenching liquid may encounter difficulty penetrating the intact coke loaf. Moreover, an unacceptable amount of coke may be lost during the quenching process. For example, coke may fly out of the container in which it is otherwise contained (i.e., "flied coke") during the quenching process. In addition, an amount of particulate matter may be generated during the quenching process and vented through the quench tower into the atmosphere outside of the quench tower.

[0005] These problems of conventional systems lead to myriad disadvantages that lower the overall efficiency of the coking operation. For example, the difficulty of penetrating an intact or partially intact coke loaf may result in increased water usage, longer quench times that can cripple the throughput of the coke plant, excessive moisture levels in the coke, large variations in coke moisture, and increased risk of melting plant equipment if the coke is not cooled rapidly enough. In addition, conventional systems may vent an unacceptable level of particulate matter into the environment, thereby creating a need for more effective environmental controls. These problems may occur in any coking operation but are particularly applicable to stamp charged coking operations, in which the coal is compacted prior to heating. As another example, a large amount of flied coke or particulate matter that escapes the quench tower may lower the efficiency of the coking operation by yielding less coke for screening and loading into rail cars or trucks for shipment at the end of the quenching process. Therefore, a need exists for an improved quench tower that provides a quenching operation that more efficiently penetrates an amount of coke with a quenching liquid, reduces the amount of coke loss due to flied coke, reduces the amount of particulate matter that escapes the quench tower, and reduces the particulate matter, emissions, and steam that escapes the bottom of the quench tower.

BRIEF DESCRIPTION OF THE DRAWINGS

[0006] Figure 1 is a diagram illustrating an overview of a coke making process.

[0007] Figure 2A is a top view of a first embodiment of an improved quench tower as disclosed herein.

[0008] Figure 2B is a front view of a first embodiment of an improved quench tower as disclosed herein.

[0009] Figure 2C is a side view of a first embodiment of an improved quench tower as disclosed herein.

[0010] Figure 2D is a top view of a second embodiment of an improved quench tower as disclosed herein.

[0011] Figure 2E is a front view of a second embodiment of an improved quench tower as disclosed herein.

[0012] Figure 2F is a side view of a second embodiment of an improved quench tower as disclosed herein.

[0013] Figure 3 is a detailed side view showing components of an improved quench tower as disclosed herein.

[0014] Figure 4 is a flow diagram of an embodiment of a quenching procedure as disclosed herein.

[0015] Figure 5A is a three-dimensional view of a quench tower having a quench tower effective perimeter area, a quench tower exit perimeter area, and a height according to a first embodiment.

[0016] Figure 5B is an example graph depicting the amount of steam captured in a quench tower as a function of coverage area ratio to tower height according to the embodiment of Figure 5A.

[0017] Figure 5C is an example graph depicting a preferred area to maximize steam capture in a quench tower as a function of coverage area ratio to tower height according to the embodiment of Figure 5A.

[0018] Figure 6A is a three-dimensional view of a quench tower having a quench tower effective perimeter area, a quench tower exit perimeter area, and a height according to a second embodiment.

[0019] Figure 6B is an example graph depicting the amount of steam captured in a quench tower as a function of coverage area ratio to tower height according to the embodiment of Figure 6A.

[0020] Figure 6C is an example graph depicting a preferred area to maximize steam capture in a quench tower as a function of coverage area ratio to tower height according to the embodiment of Figure 6A.

[0021] Figure 7 is a side view of an embodiment of a quench tower having a control opening as disclosed herein.

DETAILED DESCRIPTION

[0022] The present technology is generally directed to methods and systems for an improved quench tower. More specifically, some embodiments are directed to methods and systems that improve the ability of the quench tower to recover particulate matter, steam, and emissions that escape from the base of the quench tower (i.e., improved recovery). Moreover, some embodiments are directed to methods and systems that improve the draft and draft distribution (or "draft distribution profile") of the quench tower. The improved quench tower includes one or more sheds (each having a shed physical perimeter) to enlarge the physical perimeter or the effective physical perimeter of the quench tower to reduce the amount of particulate matter, emissions, and steam loss during the quenching process. Some embodiments are directed to methods and systems for an improved quench baffle design and arrangement formed of a plurality of single chevrons or multi-turn chevrons adapted to prevent particulate matter from escaping the quench tower. Some embodiments are directed to methods and systems for an improved quench baffle spray nozzle design and arrangement that enables one or more quench spray nozzles to wet the baffles prior to quenching, suppress dust during quenching, and/or clean the baffles after quenching. Some embodiments are directed to a quench nozzle design and arrangement that enables the quench nozzles to be fired in one or more discrete stages during the quenching process. Some embodiments are directed to methods and systems for a flined coke reclaim baffle that redirects flined coke into a train car located within the quench tower.

[0023] Specific details of several embodiments of the technology are described below with reference to Figures 1–7. Other details describing well-known structures and systems often associated with coke making and/or quenching have not been set forth in the following disclosure to avoid unnecessarily obscuring the description of the various embodiments of the technology. Many of the details, dimensions, angles, and other features shown in the Figures are merely illustrative of particular embodiments of the technology. Accordingly, other embodiments can have other details, dimensions, angles, and features without departing from the spirit or scope of the present technology. A person of ordinary skill in the art, therefore, will accordingly understand that the technology may have other embodiments with additional elements, or the technology may have other embodiments without several of the features shown and described below with reference to Figures 1–4.

[0024] Figure 1 is a diagram illustrating an overview of a coke making process. A mass of coal 105 is loaded into coke oven 110 and baked at temperatures that typically exceed 2000 degrees Fahrenheit. Once the coal is “coked out” or fully coked, the resulting coke loaf is removed from the oven and transferred to a train car, hot car, quench car, or combined hot car/quench car 125. The coke loaf is then transported to quench tower 120 for quenching. Further details regarding the present invention (including further details regarding the coking process, train cars, hot cars, quench cars, and combined hot car/quench cars) may be found in commonly-assigned U.S. Patent Application No. 13/730,796, filed on December 28, 2012, entitled METHODS AND SYSTEMS FOR IMPROVED COKE QUENCHING.

Quench Tower Design and Arrangement

[0025] An improved quench tower design is provided herein that maximizes the overall efficiency of the quenching process, particularly as it relates to lowering emissions and particulate matter generated during the quenching process. The improved design maximizes efficiency by expanding the actual perimeter and/or the effective perimeter of the quench tower. As explained in more detail below, the actual perimeter may be expanded through the addition of one or more sheds attached to the sides of the quench tower geometry in order to increase the physical area enclosed by the quench tower. The effective perimeter likewise may be

expanded by adding one or more sheds to the quench tower geometry. In addition, as also explained in more detail below, the recovery of particulate matter and steam can also be improved by closing one or more sides of the quench tower. A variety of means may be used to close the one or more sides of the quench tower, including the installation of a barrier such as a door or curtain. A person of ordinary skill in the art will appreciate that any such barrier may be used to cover one or more openings in any number of walls of the quench tower and/or to cover one or more openings in any number of sheds attached to the quench tower.

[0026] Closing off more sides of the quench tower improves the particulate matter, emissions, and steam recovery by improving the draft at the sections of the quench tower still open to the atmosphere. The draft of the tower can also be improved to lower the amount of particulate matter, emissions, and steam that escape from the bottom by making the tower taller. In cases where there is still loss of particulate matter, emissions, and steam from the quench tower, a shed can be added above the open areas to funnel the lost particulates, emissions, and steam back into the tower leading to improved overall particulate matter, emissions, and steam recovery. By using sheds, closing off select walls of the quench tower, and varying the quench tower height, the quench tower design can be optimized to give better environmental performance at a lower cost. A shed may have one or more side walls, or may have no side walls. In addition, sheds can be retrofitted to existing quench towers to improve their performance. The performance is improved by enlarging the coverage area effectively corresponding to the existing quench tower height based on the proposed correlations.

[0027] The improved quench tower design disclosed herein also includes one or more openings in the quench tower in order to improve the airflow (or "draft distribution") through the quench tower. The one or more openings may be located in a wall, shed, or barrier of the quench tower and preferably are located at an elevation that is lower than the elevation of a train car containing an amount of coke to be quenched. The lower elevation of the openings allows air to flow into the quench tower from the bottom of the quench tower, where the air then flows in an upward direction through the quench tower. As the air flows upwards through the quench tower, the draft contacts the train car and carries steam and emissions from the train car in an upward direction. As a result, steam and emissions generated

during quenching are carried upward through the quench tower—as opposed to escaping from one or more sides of the quench tower—where particulate matter may be trapped from the air by one or more baffles residing in an upper portion of the quench tower, as described more fully below. The improved quench tower also provides reclaim baffles for recapturing flied coke generated during the quenching process. The improved quench tower therefore allows for improved retention of flied coke and overall lower emissions, particulate matter, and steam loss as compared to conventional quenching systems.

[0028] Figures 2A–2C illustrate a first embodiment of an improved quench tower as disclosed herein. Side walls 260a–260d are joined together to form the base of quench tower 200. The side walls may be joined together by any available means, including fasteners, adhesives, welded connections, or by any other suitable building construction means known to persons of ordinary skill in the art. In the embodiment of Figures 2A–2C, one shed is attached to each side wall of quench tower 200: shed 210 is attached to side wall 260a; shed 215 is attached to side wall 260b; shed 220 is attached to side wall 260c; and shed 225 is attached to side wall 260d. In addition, a physical opening exists between each side wall and the respective shed to which each side wall is attached. The physical opening may be created by removing a portion of the side wall to create an area that extends from base portion 205 of the quench tower into the respective shed. For example, a physical opening in side wall 260a (not shown) creates an area that extends from base portion 205 into shed 210.

[0029] Further, each shed may contain one or more exterior openings that may be used for a variety of purposes, including entry and/or exit of a train car, dumping of coke from a train car, or improving the draft distribution through the quench tower. The exterior opening may be uncovered, fully covered, or partially covered by one or more doors or curtains. One or more doors may be formed of any material suitable to provide partial or full coverage of an exterior opening in the shed, such as wood, metal, or composite material. Furthermore, a door may be of any type suitable to provide partial or full coverage of the exterior opening of the shed, such as a sliding door or a hinged door. The curtain may be formed of metal, fabric, mesh, or any other material that is relatively easily movable and suitable to provide partial or full coverage of an exterior opening of the shed. For example, the curtain may be

formed of any material allowing an amount of coke to be emptied out of a quench car without the need to manually operate a door or other barrier. In the case of an opening with a door, curtain or partially covered opening that can have particulate matter, emissions or steam leaking out of the bottom, a shed can be placed over the opening to collect the lost particulate matter, emissions, and steam. The shed may have an opening above the door to allow the collected particulates, emissions, and steam to be fed back into the quench tower leading to improved environmental performance, as discussed in additional detail below in reference to Figure 7.

[0030] As illustrated in the embodiment of Figure 2C, a train car 240 may enter quench tower 200 through a sliding door 230, continue into shed 220 through the opening revealed by door 230, and continue into the quench tower base 205 through an opening in side wall 260c, where the coke in the train car may be quenched as described in more detail below. After quenching, the train car 240 may exit the quench tower 200 through the same path used to enter the quench tower, or the train car may exit the quench tower through a different path. For example, train car 240 may exit the quench tower by traveling through an opening in side wall 260d into shed 225, and exiting the shed by traveling through an opening revealed by hinged door 235. Alternatively, for example, the train car may exit the quench tower by traveling through an opening in side wall 260a into shed 210, and exiting the shed by traveling through an exterior opening (not shown) in shed 210. As an alternative to a movable barrier such as a door or curtain, the ends of the train car can be made to fill a hole at the end of the quench tower or can be made to fully or partially fill a quench tower opening, thereby eliminating the need for a movable barrier at the filled opening. A person of ordinary skill in the art will recognize that the train car 240 may enter and exit the quench tower 200 through any combination of openings in the quench tower.

[0031] One or more surfaces of the quench tower may include any number of openings to increase the amount of particulate matter that is captured by the quench tower. For example, referring to Figure 3, quench tower 300 contains openings 395a–395b which are located at an elevation that is lower than train car 370 containing an amount of coke 390. During quenching, the ambient air entrains into the quench tower through openings 395a–395b, the entrained air flows upward to make contact with train car 370 and an amount of coke 390, and then the entrained

air carries particulate matter, steam, and emissions from the coke in an upward direction through the quench tower to be trapped by one or more baffles (e.g., 310 and 305), as described in more detail below. The placement of openings 395a–395b below train car 370 provides for a significant improvement in particulate matter, emissions, and steam capture and dispersion as compared to openings placed above the train car. For example, when placed above the train car, the entrained air flows upward through the quench tower without first contacting train car 370 and coke 390. As a result, while still effective, a smaller amount of particulate matter from the coke is carried upward through the quench tower to be captured by the baffles. Additionally or alternatively to openings 395a–395b, one or more openings may be created in the area underneath the tower (i.e., the area between the quench tower and the ground below).

[0032] Figures 2D–2F illustrate a second embodiment of an improved quench tower as disclosed herein. Side walls 260a–260d are joined together to form the base of quench tower 200. In the embodiment of Figures 2D–2F, one shed is attached to each of two side walls of quench tower 200, while the remaining two side walls have no shed attached thereto: shed 210 is attached to side wall 260a and shed 225 is attached to side wall 260d; side walls 260b and 260c have no side walls attached. A physical opening exists between side wall 260a and shed 210, and a physical opening exists between side wall 260d and shed 225. The physical openings may be created by removing a portion of the side wall to create an area that extends from base portion 205 of the quench tower into sheds 210 and 225. As described in reference to the embodiment of Figures 2A–2C, the quench tower may include one or more openings located below a train car containing coke in order to improve the draft distribution through the quench tower, thereby resulting in more effective collection of emissions, particulate matter, and steam generated during quenching. Returning to the second embodiment, Figure 2F illustrates a train car 240 that may enter quench tower 200 through a sliding door 230 and proceed directly into the quench tower base 205, where the coke in the train car may be quenched as described in more detail below. After quenching, the train car 240 may exit the quench tower 200 through the same path used to enter the quench tower or a different path, as described above.

[0033] In the embodiment of Figure 7, a quench tower 700 includes an attached shed 725 having a door 705. A control opening 710 (e.g., an opening having any shape, including a circle, square, etc.) is created in the portion of the quench tower wall situated underneath or above the shed 725. When steam and/or particulate matter escapes from the sides, top, or bottom of the quench tower door 705, the control opening 710 redirects the escaped steam and/or particulate matter back into the quench tower. A person of ordinary skill in the art will appreciate that one or more control openings may be located in a variety of different positions in the quench tower structure, either in conjunction with a shed or not in conjunction with a shed.

[0034] The embodiments described herein are useful for designing new quench towers that are more efficient than current towers, as well as retrofitting existing towers that would benefit from more efficient operations. For example, one or more sheds can be added to an existing tower to improve otherwise poor recovery of steam, particulate matter, and emissions from the bottom of the tower. Moreover, the embodiments are useful to design an optimal quench tower by optimizing the quench tower effective perimeter area, quench tower exit perimeter area, quench tower height, sheds, walls (e.g., used to block bottom openings of the quench tower), doors, and train cars. These optimizations allow the design of a more effective and less costly quench tower (i.e., shorter quench tower) with equivalent or better recovery.

[0035] A person of ordinary skill in the art will appreciate that additional embodiments of the quench tower are possible that are consistent with the designs disclosed herein. For example, the quench tower may consist of more than four side walls, may consist of fewer than four side walls, or may take a variety of different physical shapes, including shapes that may be fully or partially curvilinear. A person of ordinary skill in the art will appreciate that the base of the quench tower base may contain any number of sheds, including no sheds, and will further recognize that each shed may or may not contain one or more doors of various types, including door types not specifically disclosed herein. A person of ordinary skill in the art will further appreciate that a train car may enter the quench tower through multiple different openings, may exit the quench tower through multiple different openings, and may enter the quench tower through a same or different opening than used for exiting the quench tower.

[0036] As used herein, a quench tower exit perimeter refers to the perimeter at the top of the quench tower defined by a partially open top portion of the quench tower that is defined by the side walls of the quench tower. A quench tower physical perimeter refers to the perimeter at the bottom of the quench tower defined by a partially open top portion of the quench tower that is defined by the side walls of the quench tower. A shed physical perimeter refers to the perimeter defined by one or more outwardly extending surfaces joined to a side wall of the quench tower to create a substantially closed top portion. A quench tower effective perimeter refers to the combination of the quench tower physical perimeter and one or more shed physical perimeters. A train car perimeter refers to the perimeter defined by the sides of a train car. An improved draft distribution or an improved draft distribution profile refers to improved three-dimensional spatial draft distribution within the quench tower effective perimeter that can be actively or passively enhanced by altering the dimensions of the tower or by adding a shed. As discussed herein, one of the benefits of enhancing draft distribution of the quench tower is lowering the loss of particulate matter, emissions and steam from one or more openings in the bottom portion of the quench tower.

[0037] The effective perimeter of the quench tower can be enlarged by adding a shed. The performance of the quench tower can be enhanced by adjusting the quench tower effective perimeter (i.e., adding a shed to the quench tower physical perimeter in order to expand the quench tower effective perimeter), adjusting the quench tower exit perimeter at the top of quench tower (e.g., making the quench tower exit perimeter significantly larger than the quench car), and adjusting the height of the quench tower to increase overall draft of the quench tower). Figure 5A shows a three-dimensional view of a quench tower 500 having a quench tower effective perimeter area 505, a quench tower exit perimeter area 510, and a height 515. The bottom of quench tower 500 is open on all sides (see, for example, opening 511). Figure 5B is an example graph depicting the amount of steam captured in one embodiment of quench tower 500 as a function of coverage area ratio to tower height. Figure 5C is an example graph depicting a preferred area to maximize steam capture in the quench tower as a function of coverage area ratio to tower height. Hereinafter, Figures 5A–5C will be collectively referred to as Figure 5.

[0038] The coverage area ratio is calculated by dividing the quench tower effective perimeter area by the quench tower exit perimeter area. The percentage of steam captured by the quench tower is then modeled as a graph by plotting the coverage area ratio against the tower height. For example, in the steam capture graph 550, the coverage area ratio is plotted on the y axis and the tower height is plotted on the x axis. In the example of graph 550, a given tower height/coverage area ratio combination that falls on slope 560 would result in steam capture of 60 percent, a given tower height/coverage area ratio combination that falls on slope 565 would result in steam capture of 80 percent, a given tower height/coverage area ratio combination that falls on slope 570 would result in steam capture of 90 percent, and a given tower height/coverage area ratio combination that falls on slope 575 would result in steam capture of 100 percent. The increased steam capture coverage and reduced loss from the bottom of the quench tower are also indicative of lower losses of particulate matter and other emissions from one or more openings in the bottom portion of the quench tower.

[0039] The graph 550 therefore demonstrates the relationship between the quench tower effective perimeter area, the quench tower exit perimeter area at the top of the quench tower, and the height of the quench tower as related to the amount of steam captured by the quench tower. For example, a graph such as graph 550 may indicate that a straight quench tower (i.e., a quench tower having a quench tower effective perimeter area that is substantially equal to the quench tower exit perimeter area, thereby resulting in a coverage area ratio equal to 1) may require a height of 250 feet in order to capture 100 percent of steam from the quench tower, while a quench tower with sheds yielding a Coverage Area Ratio of 2.0 would reduce the quench tower height requirement from 250 feet to 130 feet in order to capture 100 percent of steam from the quench tower. Moreover, the graph 551 includes a preferred slope 575 that represents various combinations of coverage area ratio and tower height that result in 100 percent steam capture. For example, according to graph 551, a coverage area ratio of 1.7 and a tower height of 150 feet would yield a 100 percent steam capture rate (as indicated by point 576). Similarly, a coverage area ratio of 1.33 and a tower height of 172 feet would yield a 100 percent steam capture rate (as indicated by point 577).

[0040] The steam capture properties of the quench tower may vary with as one or more sides of the quench tower are opened or closed. Figure 6A shows a three-dimensional view of a quench tower 600 having a quench tower effective perimeter area 605, a quench tower exit perimeter area 610, and a height 615. The bottom of quench tower 600 is closed on one side 611 and is open on the remaining sides. Figure 6B is an example graph depicting the amount of steam captured in one embodiment of quench tower 600 as a function of coverage area ratio to tower height. Figure 6C is an example graph depicting a preferred area to maximize steam capture in the quench tower as a function of coverage area ratio to tower height. Hereinafter, Figures 6A–6C will be collectively referred to as Figure 6. Although specific values and ranges are used with respect to Figures 5 and 6, a person of ordinary skill in the art will appreciate that the specific values used are for illustrative purposes only and are not intended to limit the scope of the subject matter disclosed herein.

[0041] Graph 651 includes a preferred slope 675 that represents various combinations of coverage area ratio and tower height that result in 100 percent steam capture (as indicated by point 676). For example, according to graph 651, a coverage area ratio of 1.93 and a tower height of 110 feet would yield a 100 percent steam capture rate (as indicated by point 677). Similarly, a coverage area ratio of 1.7 and a tower height of 130 feet would yield a 100 percent steam capture rate.

[0042] A person of ordinary skill in the art will recognize that a graph depicting the amount of steam captured in a quench tower as a function of coverage area ratio to tower height, as depicted in Figures 5 and 6, may be useful in retrofitting existing quench towers to improve overall performance and efficiency. A person of ordinary skill in the art will also recognize that, although Figures 5 and 6 are discussed in terms of steam capture, Figures 5 and 6 (and the associated discussion) are equally applicable to the capture of particulate matter and emissions.

Quench Baffle Design and Arrangement

[0043] The quench tower design disclosed herein may include one or more quench baffles located inside of the quench tower and situated above a train car containing an amount of coke to be quenched. The quench baffle comprises a

plurality of chevrons, each of which may be attached, affixed, mounted, hooked, or otherwise connected to a structure inside of the quench tower. For example, the chevrons of the baffle may be hooked onto a baffle support structure that is mounted to one or more walls of the quench tower. The quench baffle may span substantially the length and/or width of the quench tower exit perimeter area formed by the quench tower side walls, as discussed in more detail below. The chevrons of the baffle are adapted to trap particulate matter to prevent its escape from the quench tower during the quenching process. The one or more chevrons may be formed from a variety of different materials including wood, plastic, metal, steel, or any other material suitable for trapping particulate matter. For example, a wood baffle may be advantageous in some instances because the natural profile of the wood may have a wider profile than other materials, thereby resulting in a path that is more tortuous and able to trap a greater amount of particulate matter. In addition, a wood chevron may be hooked to the quench tower rather than attached to the quench tower. A plastic chevron may be advantageous in some instances because, when statically charged, the plastic material may attract more particulate matter that can then be trapped. Similarly, a steel chevron may be advantageous in some instances because steel may allow for easier construction and/or mounting to the quench tower, and may result in a more tortuous path and a more desirable pressure drop in the tower.

[0044] The one or more chevrons may take a variety of shapes, including a single chevron shape or a multi-turn chevron shape. In the case of a single chevron shape, the single chevron is attached or hooked to the quench tower at an angle that provides a surface area that contacts air that flows in an upward direction through the quench tower. As the air contacts the single chevron, particulate matter in the air becomes trapped on the surface area of the chevron, thereby preventing the particulate matter from being vented out of the quench tower and into the surrounding atmosphere external to the quench tower. The ability to trap particulate matter may increase further when multi-turn chevrons are used. In a multi-turn chevron design, two or more chevrons may be located relative to one another at an angle that increases the effective surface area of the chevron.

[0045] The increased surface area of the multi-chevron design and the tortuous path through the multi-turn chevron design allow for improved trapping of particulate

matter that comes into contact with the chevrons as the air flows upward through the quench tower. The one or more baffles may be sprayed with liquid to pre-wet the baffles prior to quenching in order to increase the trapping capabilities of the baffles. Additionally or alternatively, the one or more baffles may be sprayed with liquid to apply a continuous stream or spray of liquid to the baffles of the chevron during quenching. Additionally or alternatively, the one or more baffles may be sprayed with high pressure liquid to reclaim trapped particulate matter after quenching, as explained in more detail below. A person of ordinary skill in the art will appreciate that the quench tower design may employ a number of additional means to improve the ability of the baffles to trap particulate matter, including for example providing a charged baffle made of plastic or any other material suitable for attracting particulate matter to be trapped.

[0046] Figure 3 illustrates a quench tower design in accordance with embodiments disclosed herein. In particular, quench tower 300 includes a first quench baffle 305 and a second quench baffle 310, each of which extends substantially the width of the opening in the top of the quench tower. Quench baffle 305 includes a plurality of different chevron shapes, including single chevron 394, and multi-turn chevrons 325 (having two turns), 330 (having three turns), and 335 (having four turns). Quench baffle 310 is situated below quench baffle 305 and similarly includes a plurality of different chevron shapes, for example multi-turn chevrons 325 (having two turns), 335 (having four turns), and 340 (having five turns). A person of ordinary skill in the art will appreciate that a chevron may have any number of turns and may be attached or hooked to the quench tower at any angle between zero and 180 degrees with respect to the opening in the quench tower. A person of ordinary skill will further appreciate that each chevron may be separated from a neighboring chevron by a fixed or variable distance. Accordingly, the disclosed baffle design allows flexibility to select a baffle shape and separation distance, as well as a number of baffles used, to maximize the rate of particulate matter capture. For example, one design may include one baffle having chevrons with a large number of turns with relatively small spacing between each chevron (for example, two inches). A different example may include multiple layers of baffles comprising a first baffle having chevrons with a large number of turns with relatively

larger spacing between each chevron layered with a second baffle having chevrons with a small number of turns with relatively smaller spacing between each chevron.

Quench Baffle Spray Nozzle Design and Arrangement

[0047] The quench baffles disclosed herein may be equipped with one or more quench baffle spray nozzles that may be used to clean the quench baffle (including one or more chevrons comprising the quench baffle), wet the quench baffle prior to quenching in order to increase the amount of particulate matter that may be trapped during quenching, dislodge trapped particulate matter from the quench baffle after quenching for recapture, as described above, and/or suppress dust generated during quenching, as described in more detail below. The quench baffle spray nozzles may be mounted in a variety of positions within the quench tower. In one embodiment, a quench baffle spray nozzle may be located on the interior of the quench tower in a position that is situated above at least one quench baffle. If situated above a quench baffle, the quench baffle spray nozzle may be angled in a downward direction in order to dispose an amount of liquid onto the quench baffle below or towards a mass of coke below. In another embodiment, a quench baffle spray nozzle may be located on the interior of the quench tower in a position that is situated below at least one quench baffle. If situated below a quench baffle, the quench baffle spray nozzle may be angled in an upward direction in order to dispose an amount of liquid onto the quench baffle above.

[0048] In another embodiment, a quench baffle spray nozzle may be located on the interior of the quench tower between two quench baffles. If situated between two quench baffles, the quench baffle spray nozzle may be angled in an upward direction in order to dispose an amount of liquid onto the quench baffle above or may be angled in a downward direction in order to dispose an amount of liquid onto the quench baffle below or towards a mass of coke below. Additionally, the nozzle may employ a mechanism allowing the angle to be adjusted upward or downward in order to service either the above baffle or the below baffle (as well as the dust generated from quenching the mass of coke below), as needed. In still another embodiment, a quench baffle spray nozzle may be located on the exterior of the quench tower and angled in a downward direction in order to dispose an amount of liquid onto one or

more quench baffles located inside of the quench tower as well as to suppress an amount of dust that is generated before and during quenching. A person of ordinary skill in the art will appreciate that the one or more quench baffle spray nozzles dispose a stream or spray of liquid that is either pressurized or unpressurized. A person of ordinary skill in the art will further appreciate that the one or more quench baffle spray nozzles may dispose a variety of liquids, including water, a cleaning solution, a protective sealant, or any other liquid (or combination thereof) suitable for cleaning the quench baffle, removing particulate matter from the quench baffle, or protecting the materials of the quench baffle. A person of ordinary skill in the art will further appreciate that the one or more quench baffle spray nozzles may dispose the one or more liquids in a continuous intermittent stream or spray.

[0049] Figure 3 illustrates a quench baffle spray design and arrangement in accordance with embodiments of the technology disclosed herein. A first set of baffle spray nozzles 315a and 315b are located inside of quench tower 300 below quench baffle 310. As illustrated in Figure 3, baffle spray nozzles 315a and 315b are connected to quench tower 300 via mounts 320 and are angled in an upward direction towards quench baffle 310. Baffle spray nozzles 315a and/or 315b may dispose an amount of liquid onto quench baffle 310 for a variety of different purposes, including wetting, cleaning, or protecting one or more quench baffles, as described above. Baffle spray nozzles 315a and/or 315b (or a different set of baffles (not shown)) may also be used to knock down particulate matter (including small or large particulate matter) that is generated during quenching. A second set of baffle spray nozzles 315c and 315d are located inside of quench tower 300 between quench baffles 305 and 310. As illustrated, in Figure 3, baffle spray nozzles 315c and/or 315d may be angled in an upward direction towards quench baffle 305 in order to dispose an amount of liquid onto quench baffle 305. Alternatively, baffle spray nozzles 315c and/or 315d may be angled in a downward direction towards quench baffle 310 in order to dispose an amount of liquid onto quench baffle 310. A third set of baffle spray nozzles 315e and 315f are located on the exterior of quench tower 300 above quench baffle 305. As illustrated in Figure 3, baffle spray nozzles 315e and 315f are angled in a downward direction towards quench baffle 305 and may dispose an amount of liquid onto quench baffle 305 for a variety of different

purposes, including wetting, cleaning, or protecting one or more quench baffles, and dust suppression, as described above.

[0050] A person of ordinary skill in the art will appreciate that a greater or smaller number of baffle spray nozzles may be used. For example the quench tower may contain only a single baffle spray nozzle or may contain multiple sets of baffle spray nozzles. A person of ordinary skill will further appreciate that the one or more baffle spray nozzles may be angled in different directions. For example, baffle spray nozzle 315c may be angled in a downward direction at the same time that baffle spray nozzle 315d is angled in an upward direction. A person of ordinary skill in the art will appreciate that one or more baffle spray nozzles may be dedicated to different functions. For example, one set of baffle spray nozzles may be dedicated to cleaning the baffle, a different set of baffle spray nozzles may be dedicated to wetting the baffle, and still a different set of baffle spray nozzles may be dedicated to dust suppression. A person of ordinary skill in the art will further appreciate that one or more baffle spray nozzles may deliver a pressurized stream or spray of liquid while one or more different baffle spray nozzles may deliver an unpressurized stream or spray of liquid. A person of ordinary skill in the art will appreciate that the pressure and/or type of baffle spray nozzle may be changed in accordance with the type of particulate matter to be removed from the baffles. For example, a larger nozzle with higher pressure may be used to remove relatively large particulate matter from one or more baffles, while a smaller nozzle with lower pressure may be used to remove relatively small particulate matter from one or more baffles. A person of ordinary skill in the art will further appreciate that the one or more baffle spray nozzles may dispose a different type of liquid onto a respective quench baffle, including water, a cleaning solution, a protective sealant, or any other liquid (or combination thereof) suitable for cleaning the quench baffle, removing particulate matter from the quench baffle, or protecting the materials of the quench baffle. A person of ordinary skill in the art will further appreciate that the one or more baffle spray nozzles may dispose the different types of liquids in a continuous intermittent stream or spray.

Quench Nozzle Design and Arrangement

[0051] The improved quench tower disclosed herein includes one or more quench spray nozzles adapted to dispose an amount of liquid onto a mass of coke to be quenched. The one or more quench spray nozzles may be mounted in the interior of the quench tower in a position located above the mass of coke to be quenched. The quench spray nozzles may be coupled together at various angles to form a quench spray nozzle array. For example, one or more of the quench nozzles may be oriented to dispose an amount of liquid onto the mass of coke at an angle of between zero and 90 degrees with respect to a first or second side of the mass of coke, while one or more additional quench nozzles may be oriented to dispose an amount of liquid onto the mass of coke in a generally downward direction at an angle roughly perpendicular to the mass of coke.

[0052] Moreover, the one or more quench nozzles may be situated to dispose the amount of liquid onto different portions of the mass of coke. For example, one or more nozzles may be situated to dispose an amount of liquid onto a center region of the mass of coke, a different one or more nozzles may be situated to dispose an amount of liquid onto one edge of the mass of coke, and/or one or more nozzles may be situated to dispose an amount of liquid onto the opposite edge of the mass of coke. During quenching, the one or more nozzles may be fired in stages to optimize the quenching process. For example, one or more nozzles may dispose an amount of liquid onto the side regions of the mass of coke during an initial quenching stage, while a different one or more nozzles may dispose an amount of liquid onto the center region of the mass of coke during a subsequent quenching stage. A person of ordinary skill in the art will appreciate that the quenching process may include any number of quenching stages and that individual quench nozzles or groups of quench nozzles may be active during all or fewer than all of the quenching stages. In addition, each quench nozzle may be tuned in order to control the location, the amount of liquid disposed, and the firing of the individual nozzle.

[0053] Figure 3 illustrates a quench tower 300 having a quench spray nozzle array 392 in accordance with embodiments disclosed herein. Quench spray nozzle array 392 includes quench spray nozzles 355a–355c, 360a–360c, and 365a–365c, which are located above a train car 370 containing a mass of coke to be quenched. Quench spray nozzles 355a–355c and 365a–365c are oriented to dispose an amount of liquid onto the mass of coke at an angle of between zero and 90 degrees

with respect to a first side (e.g., the left side) of the mass of coke or a second side (e.g., the right side) of the mass of coke. Quench spray nozzles 360a–360c are oriented at an angle roughly perpendicular to the mass of coke in order to dispose an amount of liquid onto the mass of coke. Quench spray nozzles 360a–360c are adapted to dispose an amount of liquid on the center region of the coke to be quenched, quench spray nozzles 355a–355c are adapted to dispose an amount of liquid on the left region of the coke to be quenched, and quench spray nozzles 365a–365c are adapted to dispose an amount of liquid on the right region of the coke to be quenched. As discussed above, the one or more quench nozzles may be fired in phases to achieve more efficient quenching. For example, quench spray nozzles 355a–355c and 365a–365c may be active during a first phase of the quenching process, while quench spray nozzles 360a–360c may be active during a subsequent phase of the quenching process. In addition, the quench spray nozzles may be pressurized differently to meet coke quench needs or to further break an intact amount of coke. A person of ordinary skill in the art will appreciate that, in addition to quench spray nozzle array 392, one or more additional nozzle arrays (not shown) may be located within the quench tower above a mass of coke. The one or more additional nozzle arrays may be adapted to perform a variety of different purposes, including quenching the mass of coke or suppressing an amount of dust generated during the quenching process.

Example Quench Procedure

[0054] Figure 4 illustrates an example quench procedure 400 in accordance with the embodiments disclosed herein. At block 405, a quench car containing an amount of coke to be quenched enters the quench tower 300. At step 410, one or more baffle spray nozzles wets the quench baffles by disposing an amount of liquid onto the quench baffles in order to increase the efficiency of particulate matter removal during the quenching process. At step 415, the quenching sequence is started. The quenching sequence may include, for example, a first phase that disposes an amount of liquid on both edges of the amount of coke to be quenched by firing quench nozzles 355a–355c and 365a–355c while not firing quench nozzles 360a–360c. At the conclusion of the first quenching phase, quench nozzles 355a–355c and 365a–355c may be turned off, and quench nozzles 360a–360b may be

fired to dispose an amount of liquid onto the center region of the amount of coke to be quenched, or vice versa. A person of ordinary skill will appreciate that the quenching sequence may include any number of individual phases.

[0055] While the quenching sequence is in progress—particularly towards the beginning of the quenching sequence—a dust suppression feature may be performed at step 420. The dust suppression feature fires one or more baffle spray nozzles before or during the quenching process in order to suppress dust or particulate matter that may rise from the mass of coke (before the quenching process, during the quenching process, or as a result of a delay in the quenching process) by knocking down particulate matter and dust in the air. The dust suppression feature may be activated towards the beginning of the quenching process and may be deactivated before quenching is completed at step 425. For example, the dust suppression feature may be activated during the first 10 seconds of the quenching process (when a plume of particulate matter typically rises from the coke being quenched), although a person of ordinary skill will recognize that the dust suppression period may last for a longer or shorter period of time during quenching. A person of ordinary skill also will recognize that one or more quench baffle spray nozzles may continue to wet one or more baffles (as discussed in reference to step 410) during the dust suppression period to increase the amount of particulate matter that is captured during quenching. After the quenching sequence has completed at step 425, the quench baffles are cleaned via the baffle spray nozzles, as described above. At step 435, the train car containing the quenched coke may exit the quench tower.

[0056] During the quenching process, an amount of flined coke and/or reclaimed coke may be directed back into the train car via one or more reclaim baffles 380 that are attached to an interior surface of the quench tower above the train car containing the coke to be quenched. The one or more reclaim baffles may be sloped downward such that any flined coke or reclaimed coke coming into contact with the reclaim baffles is redirected into the train car.

[0057] A person of ordinary skill in the art will appreciate that the steps of the quenching procedure may be performed in the same order or a different order than depicted in the flow diagram of Figure 4 and as described herein. A person of ordinary skill in the art will further appreciate that two or more of the steps of the

illustrated quenching procedure may be performed in parallel. For example, wetting the quench baffles (step 410) may occur either before or after the train car enters the quench tower (step 405) or may occur during the quench (e.g., steps 415–425). As another example, the train car may exit the quench tower (step 435) either before or after the quench baffles are cleaned (step 430). As yet another example, the quench baffles may be cleaned (step 430) at the same time that the train car exits the quench tower (step 435).

[0058] Various aspects of the quenching procedure may be automated or optimized through the use of one or more sensors and/or input devices located in or around the quench tower and coupled to the quench tower control logic. For example, quenching parameters such as the oven number, coke tonnage, and/or coke size (e.g., height, width, or thickness of the mass of coke) may be fed into the control logic at the start of the quench process, either automatically via one or more sensors or weight scales, or by manual input on a device such as a key entry pad. After the coke enters the quench tower, the one or more sensors in or around the quench tower may automatically activate one or more spray nozzles (i.e., baffle spray nozzles, quench spray nozzles, dust suppression spray nozzles, or any other nozzles of the quench tower) to wet the quench baffles, to spray mist inside of the quench tower to suppress dust or smoke, or to perform a variety of different functions as described herein.

[0059] During quenching, the quench tower control logic may use the stored quenching parameters (e.g., oven number, coke tonnage, and/or size of the coke loaf) to adjust a quenching load profile that affects the quench valves in order to deliver a certain amount of quench liquid to the quench nozzle. In addition, the quench tower control logic may adjust the quenching load profile based on a quench tower profile that corresponds to one or more quenching characteristics of the quench tower (e.g., a tendency of the quench tower to quench a mass of coke for a period of time that is either too long or too short.) Additionally or alternatively, the quench nozzle control logic may use the stored or other available information to implement a different quenching sequence to ensure that the hot coke mass is cooled uniformly and to further ensure that the amount of moisture in the coke is maintained below a target range. Additional sensing systems located in or around the quench tower, such as infrared camera systems or thermocouple arrays, may be

coupled to one or more secondary quench systems operable to further automatically or manually dispose an amount of quenching liquid onto the coke to reduce the temperature of one or more hot spots in the coke. The additional sensing systems also may be used to provide feedback to the quench tower control logic to adjust the quenching liquid for optimization of the current quench and/or future quenches. The quench tower profile may be updated in accordance with information collected by the sensing system during or after quenching. For example, if the sensing system detects that the duration of the quenching procedure was too long or too short for the amount of coke being quenched, the sensing system may update the quench tower profile to bias future quenching load profiles towards a longer or shorter quench duration, as appropriate. Additional sensing systems located outside of the quench tower may further monitor broken coke temperature and automatically or manually quench the broken coke (e.g., with a liquid cannon such as a water cannon) to cool any remaining hot spots identified by the sensing system. A person of ordinary skill will appreciate that the additional sensing system may quench the broken coke from a source (e.g., a liquid cannon such as a water cannon) that is located anywhere outside of the quench tower, such as a wharf or coke belt associated with the quench tower. For example, the source may be a spray array located above the wharf or coke belt, where one or more different sprays in the array may fire to quench one or more hot sections of the coke.

[0060] A person of ordinary skill will recognize that additional automations may be provided by the quench tower control logic. For example, the quench tower control logic may sense an amount of time that has elapsed since a mass of coke entered a quench tower. If the quench procedure for the mass of coke does not start within a predetermined amount of time, the quench tower control logic may automatically activate one or more spray nozzles to dispose an amount of liquid onto the mass of coke. Alternatively or additionally, if the baffles of the quench tower are not wet within a predetermined amount of time after the coke enters the quench tower, the quench tower control logic may automatically activate one or more baffle spray nozzles to cool down the quench tower structure. For example, if quenching does not begin within five minutes of a mass of coke entering the quench tower, then the quench tower control logic may activate a series of quench spray nozzles and dust suppression nozzles to automatically begin the quenching process.

[0061] From the foregoing it will be appreciated that, although specific embodiments of the technology have been described herein for purposes of illustration, various modifications may be made without deviating from the spirit and scope of the technology. Further, certain aspects of the new technology described in the context of particular embodiments may be combined or eliminated in other embodiments. Moreover, while advantages associated with certain embodiments of the technology have been described in the context of those embodiments, other embodiments may also exhibit such advantages, and not all embodiments need necessarily exhibit such advantages to fall within the scope of the technology. Accordingly, the disclosure and associated technology can encompass other embodiments not expressly shown or described herein. Thus, the disclosure is not limited except as by the appended claims.

Examples:

1. A system for quenching coke, comprising:

a quench tower formed from a plurality of side walls joined together to create a partially open top portion that defines a quench tower physical perimeter, at least one side of the quench tower containing an opening through which a train car may enter and/or exit; and

one or more sheds formed from one or more outwardly extending surfaces joined to a side wall of the quench tower to create a substantially closed top portion that defines a shed physical perimeter, wherein:

a combination of the quench tower physical perimeter and the shed physical perimeter defines a quench tower effective perimeter;

the quench tower effective perimeter is larger than the quench tower physical perimeter;

the quench tower physical perimeter is larger than or equal to a train car perimeter, the train car perimeter being defined by a plurality of sides joined together to form the train car; and

the quench tower effective perimeter is configured to provide an enhanced draft distribution profile.

2. The system of example 1, further comprising one or more tower baffles attached to an interior surface of the quench tower, each tower baffle containing a plurality of chevrons.

3. The system of example 2, further comprising one or more tower baffle spray nozzles attached to at least one surface of the quench tower, each of the one or more tower baffle spray nozzles being angled towards at least one of the one or more tower baffles and being adapted to deliver a stream or spray of liquid onto the at least one of the one or more tower baffles.

4. The system of example 3, wherein at least one of the one or more tower baffle spray nozzles is mounted above the quench tower.

5. The system of example 3, wherein the one or more tower baffle spray nozzles is angled in an upward direction, is angled in a downward direction, or is adjustable to point in an upward or downward direction.

6. The system of example 3, wherein the stream or spray onto the at least one of the one or more tower baffles originates from an amount of pressurized liquid supplied to the tower baffle spray nozzle.

7. The system of example 3, wherein at least one of the one or more tower baffle spray nozzles is attached to an interior surface of the quench tower.

8. The system of example 3, wherein at least one of the one or more tower baffle spray nozzles is attached to a surface that is exterior to the quench tower.

9. The system of example 1, further comprising one or more quench spray nozzles attached to at least one surface of the quench tower, each quench spray

nozzle being fixed at a quench nozzle angle with respect to a mass of coke to be quenched, and each quench spray nozzle being adapted to dispose a stream or spray of liquid onto a region of the mass of coke to be quenched.

10. The system of example 9, wherein at least one of the one or more quench spray nozzles is mounted above the quench tower.

11. The system of example 9, wherein the stream or spray of liquid onto a region of the mass of coke to be quenched originates from an amount of pressurized liquid supplied to the quench spray nozzle.

12. The system of example 9, wherein each of the one or more quench spray nozzles is adapted to deliver a stream or spray of liquid onto a region of the mass of coke to be quenched under the same pressure or a different pressure.

13. The system of example 9, wherein the quench nozzle angle is greater than 0 degrees and less than 90 degrees with respect to a first or second side of the mass of coke to be quenched.

14. The system of example 9, wherein the quench nozzle angle is 90 degrees with respect to a first side, a second side, or a center portion of the mass of coke to be quenched.

15. The system of example 9, wherein the region is a center area of the mass of coke to be quenched, or is not a center area of the mass of coke to be quenched.

16. The system of example 9, wherein the location of each of the one or more quench spray nozzles is adjustable to accommodate different sizes of coke to be quenched.

17. The system of example 1, wherein a coverage ratio for the quench tower is less than or equal to 10, the coverage ratio being equal to the quench tower

effective perimeter area divided by an area of the partially open top portion of the quench tower.

18. The system of example 1, wherein a coverage ratio for the quench tower is less than or equal to 5, the coverage ratio being equal to the quench tower effective perimeter area divided by an area of the partially open top portion of the quench tower.

19. The system of example 1, wherein a coverage ratio for the quench tower is less than or equal to 3, the coverage ratio being equal to the quench tower effective perimeter area divided by an area of the partially open top portion of the quench tower.

20. The system of example 1, wherein a coverage ratio for the quench tower is less than or equal to 2, the coverage ratio being equal to the quench tower effective perimeter area divided by an area of the partially open top portion of the quench tower.

21. The system of example 1, wherein at least one of the plurality of side walls contains an opening in a bottom portion of the side wall.

22. The system of example 21, wherein the opening in a bottom portion of the side wall is situated between the side wall and a ground-level surface underneath the quench tower.

23. The system of example 1, further comprising one or more movable barriers at least partially covering one of the one or more openings of the quench tower or one or more openings in the shed, the one or more movable barriers being a door or a curtain.

24. The system of example 23, wherein at least one of the plurality of side walls contains a control opening located above at least one of the one or more movable barriers, the control opening being operable to vent an amount of steam,

emissions, or particulate matter into an interior portion of the quench tower after the amount of steam, emissions, or particulate matter has escaped from the interior of the quench tower.

25. The system of example 1, wherein the shed has one or more side walls attached to the substantially closed top portion.

26. The system of example 1, wherein the shed has no side walls attached to the substantially closed top portion.

27. A system for quenching coke, comprising:

a quench tower formed from a plurality of side walls joined together to create a partially open top portion that defines a quench tower physical perimeter, at least one side of the quench tower containing an opening through which a train car may enter and/or exit; and

one or more tower baffles attached to an interior surface of the quench tower, each tower baffle having a plurality of chevrons located at an angle with respect to the partially open top portion of the quench tower, each chevron being separated from a neighboring chevron by a separation distance, and each chevron having more than two turns.

28. The system of example 27, comprising two or more of the tower baffles.

29. The system of example 28, wherein the tower baffle is formed substantially of wood, steel, plastic, or any combination thereof.

30. The system of example 27, wherein the angle is the same or different for at least two chevrons in the plurality of chevrons.

31. The system of example 27, wherein the separation distance is the same or different for at least two chevrons in the plurality of chevrons.

32. The system of example 27, further comprising one or more tower baffle spray nozzles attached to at least one surface of the quench tower, each of the one or more tower baffle spray nozzles being angled towards at least one of the one or more tower baffles and being adapted to deliver a stream or spray of liquid onto the at least one of the one or more tower baffles.

33. The system of example 32, wherein at least one of the one or more tower baffle spray nozzles is mounted above the quench tower.

34. The system of example 32, wherein the one or more tower baffle spray nozzles is angled in an upward direction, is angled in a downward direction, or is adjustable to point in an upward or downward direction.

35. The system of example 32, wherein the stream or spray onto the at least one of the one or more tower baffles of liquid originates from an amount of pressurized liquid supplied to the tower baffle spray nozzle.

36. The system of example 32, wherein at least one of the one or more tower baffle spray nozzles is attached to an interior or exterior surface of the quench tower.

37. The system of example 36, further comprising one or more quench spray nozzles attached to at least one surface of the quench tower, each quench spray nozzle being fixed at a quench nozzle angle with respect to a mass of coke to be quenched, and each quench spray nozzle being adapted to dispose a stream or spray of liquid onto a region of the mass of coke to be quenched.

38. The system of example 37, wherein at least one of the one or more quench spray nozzles is mounted above the quench tower.

39. The system of example 37, wherein the stream or spray of liquid onto a region of the mass of coke to be quenched originates from an amount of pressurized liquid supplied to the quench spray nozzle.

40. The system of example 37, wherein each of the one or more quench spray nozzles is adapted to deliver a stream or spray of liquid onto a region of the mass of coke to be quenched under the same or different pressure.

41. The system of example 37, wherein the quench nozzle angle is greater than 0 degrees and less than 90 degrees with respect to a first or second side of the mass of coke to be quenched.

42. The system of example 37, wherein the quench nozzle angle is 90 degrees with respect to a first side, a second side, or a center portion of the mass of coke to be quenched.

43. The system of example 37, wherein the region is a center area of the mass of coke to be quenched or is not a center area of the mass of coke to be quenched.

44. The system of example 37, wherein the location of each of the one or more quench spray nozzles is adjustable to accommodate different sizes of coke to be quenched.

45. The system of example 27, further comprising one or more movable barriers at least partially covering one of the one or more openings of the quench tower, the one or more movable barriers being a door or a curtain.

46. The system of example 27, wherein a coverage ratio for the quench tower is less than or equal to 10, the coverage ratio being equal to the quench tower effective perimeter area divided by an area of the partially open top portion of the quench tower.

47. The system of example 27, wherein a coverage ratio for the quench tower is less than or equal to 5, the coverage ratio being equal to the quench tower effective perimeter area divided by an area of the partially open top portion of the quench tower.

48. The system of example 27, wherein a coverage ratio for the quench tower is less than or equal to 3, the coverage ratio being equal to the quench tower effective perimeter area divided by an area of the partially open top portion of the quench tower.

49. The system of example 27, wherein a coverage ratio for the quench tower is less than or equal to 2, the coverage ratio being equal to the quench tower effective perimeter area divided by an area of the partially open top portion of the quench tower.

50. The system of example 27, wherein at least one of the plurality of side walls contains an opening in a bottom portion of the side wall.

51. The system of example 50, wherein the opening in a bottom portion of the side wall is situated between the side wall and a ground-level surface underneath the quench tower.

52. A method for quenching coke in a quench tower, comprising:

receiving a train car containing an amount of coke to be quenched, wherein the train car is received through an opening in the quench tower;

starting a suppression action to suppress an amount of dust, wherein the suppressing comprises disposing an amount of liquid in the quench tower via one or more quench spray nozzles;

starting a quenching action to quench the amount of coke in the train car, wherein starting the quenching action comprises disposing an amount of liquid onto the amount of coke using one or more quench spray nozzles;

stopping the suppression action, wherein stopping the suppression action comprises discontinuing disposing an amount of liquid in the quench tower via one or more quench spray nozzles;

stopping the quenching action, wherein stopping the quenching action comprises discontinuing disposing an amount of liquid onto the amount of coke using the one or more quench spray nozzles; and

transporting the train car out of the quench tower, wherein the train car is transported through an opening in the quench tower.

53. The method of example 52, wherein the train car is received through a first opening and transported out of a second opening.

54. The method of example 53, wherein the first opening and the second opening are the same or different.

55. The method of example 53, wherein at least one of the first opening or the second opening is located in a front section, back section, or side section of the quench tower.

56. The method of example 53, wherein at least one of the first opening or the second opening contains a movable barrier coupled thereto that at least partially covers the opening.

57. The method of example 56, wherein the movable barrier is a door or curtain.

58. The method of example 52, further comprising wetting one or more baffles in the quench tower by disposing an amount of liquid onto the one or more baffles, the one or more baffles being attached to an interior surface of the quench tower, and the wetting taking place before the suppression action or the quenching action is started.

59. The method of example 52, further comprising wetting one or more baffles in the quench tower by disposing an amount of liquid onto the one or more

baffles for a duration of time, the one or more baffles being attached to an interior surface of the quench tower, the duration of time lasting from at least the start of the suppression action to the stop of the suppression action or lasting from at least the start of the quenching action to the stop of the quenching action.

60. The method of example 52, wherein at least one of the one or more quench spray nozzles begins disposing an amount of liquid onto the amount of coke before a different at least one of the one or more quench spray nozzles begins disposing an amount of liquid onto the amount of coke.

61. The method of example 52, wherein at least one of the one or more quench spray nozzles stops disposing an amount of liquid onto the amount of coke before a different at least one of the one or more quench spray nozzles stops disposing an amount of liquid onto the amount of coke.

62. The method of example 52, wherein at least one of the one or more quench spray nozzles disposes an amount of liquid onto a center area of the mass of coke to be quenched or an area that is not a center area of the mass of coke to be quenched.

63. The method of example 52, further comprising cleaning one or more tower baffles, wherein the cleaning comprises delivering a stream or spray of liquid onto one or more tower baffles using a tower baffle spray nozzle.

64. The method of example 63, wherein the train car is transported out of the quench tower before or after the baffles are cleaned.

65. The method of 52, wherein the quenching action and the suppression action are started simultaneously.

66. The method of 52, wherein the quenching action and the suppression action are started at different times.

67. The method of 52, wherein the quenching action and the suppression action are stopped simultaneously.

68. The method of 52, wherein the quenching action and the suppression action are stopped at different times.

69. A method for quenching coke in a quench tower, comprising:

receiving a train car containing an amount of coke to be quenched, wherein the train car is received through an opening in the quench tower;

retrieving a quench tower profile, wherein the quench tower profile corresponds to one or more characteristics of the quench tower;

receiving, automatically or via manual entry, one or more quenching parameters related to the amount of coke to be quenched;

calculating a quenching load profile based on the quench tower profile and at least some of the received quenching parameters;

starting a quenching action based at least partially on the calculated quenching load profile, wherein starting the quenching action comprises disposing an amount of liquid onto the amount of coke using one or more quench spray nozzles;

stopping a quenching action based at least partially on the calculated quenching load profile, wherein stopping the quenching action comprises discontinuing disposing an amount of liquid onto the amount of coke using one or more quench spray nozzles;

identifying one or more hot spots in the quenched coke by scanning the quenched coke to identify hot spots;

adjusting the quench tower profile based on one or more of the identified hot spots.

70. The method of example 69, wherein starting the quenching action comprises automatically disposing the amount of liquid onto the amount of coke if the quenching action is not started within a predetermined amount of time after the train car enters the quench tower.

71. The method of example 69, wherein the starting a quenching action and stopping the quenching action are based on the received one or more quenching parameters.

72. The method of example 69, wherein the scanning is performed by an infrared camera system or a thermocouple array.

73. The method of example 69, further comprising transporting the train car out of the quench tower, wherein the train car is transported through an opening in the quench tower.

74. The method of example 73, wherein the train car is received through a first opening and transported out of a second opening.

75. The method of example 74, wherein the first opening and the second opening are the same or different.

76. The method of example 74, wherein at least one of the first opening or the second opening is located in a front section of the quench tower, a back section of the quench tower, or a side section of the quench tower.

77. The method of example 74, wherein at least one of the first opening or the second opening contains a movable barrier coupled thereto that at least partially covers the opening.

78. The method of example 77, wherein the movable barrier is a door or curtain.

79. The method of example 69, wherein at least one of the one or more quench spray nozzles begins disposing an amount of liquid onto the amount of coke before a different at least one of the one or more quench spray nozzles begins disposing an amount of liquid onto the amount of coke.

80. The method of example 69, wherein at least one of the one or more quench spray nozzles stops disposing an amount of liquid onto the amount of coke before a different at least one of the one or more quench spray nozzles stops disposing an amount of liquid onto the amount of coke.

81. The method of example 69, wherein at least one of the one or more quench spray nozzles disposes an amount of liquid onto a center area of the mass of coke to be quenched.

82. The method of example 69, wherein at least one of the one or more quench spray nozzles disposes an amount of liquid onto an area that is not a center area of the mass of coke to be quenched.

83. The method of example 69, wherein the at least one of the one or more quench spray nozzles is mounted above the quench tower.

84. The method of example 69, wherein the one or more quenching parameters is an oven number, a coke tonnage, or a coke size.

85. The method of example 69, further comprising performing a secondary quenching action to quench at least one of the one or more identified hot spots, wherein performing the secondary quenching action comprises disposing an amount of liquid onto the identified hot spots for a period of time using one or more quench cannons.

86. The method of example 69, further comprising performing a secondary quenching action to quench at least one of the one or more identified hot spots, wherein performing the secondary quenching action comprises disposing an amount

of liquid onto the identified hot spots for a period of time using one or more spray nozzles located inside of a shed of the quench tower, the shed being attached to the quench tower in order to expand the quench tower effective perimeter area.

CLAIMS

I/We claim:

- [c1] 1. A system for quenching coke, comprising:
a quench tower formed from a plurality of side walls joined together to create a partially open top portion that defines a quench tower physical perimeter, at least one side of the quench tower containing an opening through which a train car may enter and/or exit; and
one or more sheds formed from one or more outwardly extending surfaces joined to a side wall of the quench tower to create a substantially closed top portion that defines a shed physical perimeter, wherein:
a combination of the quench tower physical perimeter and the shed physical perimeter defines a quench tower effective perimeter;
the quench tower effective perimeter is larger than the quench tower physical perimeter;
the quench tower physical perimeter is larger than or equal to a train car perimeter, the train car perimeter being defined by a plurality of sides joined together to form the train car; and
the quench tower effective perimeter is configured to provide an enhanced draft distribution profile.
- [c2] 2. The system of claim 1, further comprising one or more tower baffles attached to an interior surface of the quench tower, each tower baffle containing a plurality of chevrons.
- [c3] 3. The system of claim 2, further comprising one or more tower baffle spray nozzles attached to at least one surface of the quench tower, each of the one or more tower baffle spray nozzles being angled towards at least one of the

one or more tower baffles and being adapted to deliver a stream or spray of liquid onto the at least one of the one or more tower baffles.

[c4] 4. The system of claim 3, wherein at least one of the one or more tower baffle spray nozzles is mounted above the quench tower.

[c5] 5. The system of claim 3, wherein the one or more tower baffle spray nozzles is angled in an upward direction, is angled in a downward direction, or is adjustable to point in an upward or downward direction.

[c6] 6. The system of claim 3, wherein the stream or spray onto the at least one of the one or more tower baffles originates from an amount of pressurized liquid supplied to the tower baffle spray nozzle.

[c7] 7. The system of claim 3, wherein at least one of the one or more tower baffle spray nozzles is attached to an interior surface of the quench tower.

[c8] 8. The system of claim 3, wherein at least one of the one or more tower baffle spray nozzles is attached to a surface that is exterior to the quench tower.

[c9] 9. The system of claim 1, further comprising one or more quench spray nozzles attached to at least one surface of the quench tower, each quench spray nozzle being fixed at a quench nozzle angle with respect to a mass of coke to be quenched, and each quench spray nozzle being adapted to dispose a stream or spray of liquid onto a region of the mass of coke to be quenched.

[c10] 10. The system of claim 9, wherein at least one of the one or more quench spray nozzles is mounted above the quench tower.

[c11] 11. The system of claim 9, wherein the stream or spray of liquid onto a region of the mass of coke to be quenched originates from an amount of pressurized liquid supplied to the quench spray nozzle.

[c12] 12. The system of claim 9, wherein each of the one or more quench spray nozzles is adapted to deliver a stream or spray of liquid onto a region of the mass of coke to be quenched under the same pressure or a different pressure.

[c13] 13. The system of claim 9, wherein the quench nozzle angle is greater than 0 degrees and less than 90 degrees with respect to a first or second side of the mass of coke to be quenched.

[c14] 14. The system of claim 9, wherein the quench nozzle angle is 90 degrees with respect to a first side, a second side, or a center portion of the mass of coke to be quenched.

[c15] 15. The system of claim 9, wherein the region is a center area of the mass of coke to be quenched, or is not a center area of the mass of coke to be quenched.

[c16] 16. The system of claim 9, wherein the location of each of the one or more quench spray nozzles is adjustable to accommodate different sizes of coke to be quenched.

[c17] 17. The system of claim 1, wherein a coverage ratio for the quench tower is less than or equal to 10, the coverage ratio being equal to the quench tower effective perimeter area divided by an area of the partially open top portion of the quench tower.

[c18] 18. The system of claim 1, wherein a coverage ratio for the quench tower is less than or equal to 5, the coverage ratio being equal to the quench tower effective perimeter area divided by an area of the partially open top portion of the quench tower.

[c19] 19. The system of claim 1, wherein a coverage ratio for the quench tower is less than or equal to 3, the coverage ratio being equal to the quench tower

effective perimeter area divided by an area of the partially open top portion of the quench tower.

[c20] 20. The system of claim 1, wherein a coverage ratio for the quench tower is less than or equal to 2, the coverage ratio being equal to the quench tower effective perimeter area divided by an area of the partially open top portion of the quench tower.

[c21] 21. The system of claim 1, wherein at least one of the plurality of side walls contains an opening in a bottom portion of the side wall.

[c22] 22. The system of claim 21, wherein the opening in a bottom portion of the side wall is situated between the side wall and a ground-level surface underneath the quench tower.

[c23] 23. The system of claim 1, further comprising one or more movable barriers at least partially covering one of the one or more openings of the quench tower or one or more openings in the shed, the one or more movable barriers being a door or a curtain.

[c24] 24. The system of claim 23, wherein at least one of the plurality of side walls contains a control opening located above at least one of the one or more movable barriers, the control opening being operable to vent an amount of steam, emissions, or particulate matter into an interior portion of the quench tower after the amount of steam, emissions, or particulate matter has escaped from the interior of the quench tower.

[c25] 25. The system of claim 1, wherein the shed has one or more side walls attached to the substantially closed top portion.

[c26] 26. The system of claim 1, wherein the shed has no side walls attached to the substantially closed top portion.

- [c27] 27. A system for quenching coke, comprising:
a quench tower formed from a plurality of side walls joined together to create a partially open top portion that defines a quench tower physical perimeter, at least one side of the quench tower containing an opening through which a train car may enter and/or exit; and
one or more tower baffles attached to an interior surface of the quench tower, each tower baffle having a plurality of chevrons located at an angle with respect to the partially open top portion of the quench tower, each chevron being separated from a neighboring chevron by a separation distance, and each chevron having more than two turns.
- [c28] 28. The system of claim 27, comprising two or more of the tower baffles.
- [c29] 29. The system of claim 28, wherein the tower baffle is formed substantially of wood, steel, plastic, or any combination thereof.
- [c30] 30. The system of claim 27, wherein the angle is the same or different for at least two chevrons in the plurality of chevrons.
- [c31] 31. The system of claim 27, wherein the separation distance is the same or different for at least two chevrons in the plurality of chevrons.
- [c32] 32. The system of claim 27, further comprising one or more tower baffle spray nozzles attached to at least one surface of the quench tower, each of the one or more tower baffle spray nozzles being angled towards at least one of the one or more tower baffles and being adapted to deliver a stream or spray of liquid onto the at least one of the one or more tower baffles.
- [c33] 33. The system of claim 32, wherein at least one of the one or more tower baffle spray nozzles is mounted above the quench tower.

[c34] 34. The system of claim 32, wherein the one or more tower baffle spray nozzles is angled in an upward direction, is angled in a downward direction, or is adjustable to point in an upward or downward direction.

[c35] 35. The system of claim 32, wherein the stream or spray onto the at least one of the one or more tower baffles of liquid originates from an amount of pressurized liquid supplied to the tower baffle spray nozzle.

[c36] 36. The system of claim 32, wherein at least one of the one or more tower baffle spray nozzles is attached to an interior or exterior surface of the quench tower.

[c37] 37. The system of claim 36, further comprising one or more quench spray nozzles attached to at least one surface of the quench tower, each quench spray nozzle being fixed at a quench nozzle angle with respect to a mass of coke to be quenched, and each quench spray nozzle being adapted to dispose a stream or spray of liquid onto a region of the mass of coke to be quenched.

[c38] 38. The system of claim 37, wherein at least one of the one or more quench spray nozzles is mounted above the quench tower.

[c39] 39. The system of claim 37, wherein the stream or spray of liquid onto a region of the mass of coke to be quenched originates from an amount of pressurized liquid supplied to the quench spray nozzle.

[c40] 40. The system of claim 37, wherein each of the one or more quench spray nozzles is adapted to deliver a stream or spray of liquid onto a region of the mass of coke to be quenched under the same or different pressure.

[c41] 41. The system of claim 37, wherein the quench nozzle angle is greater than 0 degrees and less than 90 degrees with respect to a first or second side of the mass of coke to be quenched.

[c42] 42. The system of claim 37, wherein the quench nozzle angle is 90 degrees with respect to a first side, a second side, or a center portion of the mass of coke to be quenched.

[c43] 43. The system of claim 37, wherein the region is a center area of the mass of coke to be quenched or is not a center area of the mass of coke to be quenched.

[c44] 44. The system of claim 37, wherein the location of each of the one or more quench spray nozzles is adjustable to accommodate different sizes of coke to be quenched.

[c45] 45. The system of claim 27, further comprising one or more movable barriers at least partially covering one of the one or more openings of the quench tower, the one or more movable barriers being a door or a curtain.

[c46] 46. The system of claim 27, wherein a coverage ratio for the quench tower is less than or equal to 10, the coverage ratio being equal to the quench tower effective perimeter area divided by an area of the partially open top portion of the quench tower.

[c47] 47. The system of claim 27, wherein a coverage ratio for the quench tower is less than or equal to 5, the coverage ratio being equal to the quench tower effective perimeter area divided by an area of the partially open top portion of the quench tower.

[c48] 48. The system of claim 27, wherein a coverage ratio for the quench tower is less than or equal to 3, the coverage ratio being equal to the quench tower effective perimeter area divided by an area of the partially open top portion of the quench tower.

[c49] 49. The system of claim 27, wherein a coverage ratio for the quench tower is less than or equal to 2, the coverage ratio being equal to the quench tower

effective perimeter area divided by an area of the partially open top portion of the quench tower.

[c50] 50. The system of claim 27, wherein at least one of the plurality of side walls contains an opening in a bottom portion of the side wall.

[c51] 51. The system of claim 50, wherein the opening in a bottom portion of the side wall is situated between the side wall and a ground-level surface underneath the quench tower.

[c52] 52. A method for quenching coke in a quench tower, comprising:
receiving a train car containing an amount of coke to be quenched,
wherein the train car is received through an opening in the quench tower;
starting a suppression action to suppress an amount of dust, wherein the suppressing comprises disposing an amount of liquid in the quench tower via one or more quench spray nozzles;
starting a quenching action to quench the amount of coke in the train car, wherein starting the quenching action comprises disposing an amount of liquid onto the amount of coke using one or more quench spray nozzles;
stopping the suppression action, wherein stopping the suppression action comprises discontinuing disposing an amount of liquid in the quench tower via one or more quench spray nozzles;
stopping the quenching action, wherein stopping the quenching action comprises discontinuing disposing an amount of liquid onto the amount of coke using the one or more quench spray nozzles; and
transporting the train car out of the quench tower, wherein the train car is transported through an opening in the quench tower.

[c53] 53. The method of claim 52, wherein the train car is received through a first opening and transported out of a second opening.

[c54] 54. The method of claim 53, wherein the first opening and the second opening are the same or different.

[c55] 55. The method of claim 53, wherein at least one of the first opening or the second opening is located in a front section, back section, or side section of the quench tower.

[c56] 56. The method of claim 53, wherein at least one of the first opening or the second opening contains a movable barrier coupled thereto that at least partially covers the opening.

[c57] 57. The method of claim 56, wherein the movable barrier is a door or curtain.

[c58] 58. The method of claim 52, further comprising wetting one or more baffles in the quench tower by disposing an amount of liquid onto the one or more baffles, the one or more baffles being attached to an interior surface of the quench tower, and the wetting taking place before the suppression action or the quenching action is started.

[c59] 59. The method of claim 52, further comprising wetting one or more baffles in the quench tower by disposing an amount of liquid onto the one or more baffles for a duration of time, the one or more baffles being attached to an interior surface of the quench tower, the duration of time lasting from at least the start of the suppression action to the stop of the suppression action or lasting from at least the start of the quenching action to the stop of the quenching action.

[c60] 60. The method of claim 52, wherein at least one of the one or more quench spray nozzles begins disposing an amount of liquid onto the amount of coke before a different at least one of the one or more quench spray nozzles begins disposing an amount of liquid onto the amount of coke.

[c61] 61. The method of claim 52, wherein at least one of the one or more quench spray nozzles stops disposing an amount of liquid onto the amount of coke before a different at least one of the one or more quench spray nozzles stops disposing an amount of liquid onto the amount of coke.

[c62] 62. The method of claim 52, wherein at least one of the one or more quench spray nozzles disposes an amount of liquid onto a center area of the mass of coke to be quenched or an area that is not a center area of the mass of coke to be quenched.

[c63] 63. The method of claim 52, further comprising cleaning one or more tower baffles, wherein the cleaning comprises delivering a stream or spray of liquid onto one or more tower baffles using a tower baffle spray nozzle.

[c64] 64. The method of claim 63, wherein the train car is transported out of the quench tower before or after the baffles are cleaned.

[c65] 65. The method of 52, wherein the quenching action and the suppression action are started simultaneously.

[c66] 66. The method of 52, wherein the quenching action and the suppression action are started at different times.

[c67] 67. The method of 52, wherein the quenching action and the suppression action are stopped simultaneously.

[c68] 68. The method of 52, wherein the quenching action and the suppression action are stopped at different times.

[c69] 69. A method for quenching coke in a quench tower, comprising:
receiving a train car containing an amount of coke to be quenched,
wherein the train car is received through an opening in the quench tower;

retrieving a quench tower profile, wherein the quench tower profile corresponds to one or more characteristics of the quench tower;

receiving, automatically or via manual entry, one or more quenching parameters related to the amount of coke to be quenched;

calculating a quenching load profile based on the quench tower profile and at least some of the received quenching parameters;

starting a quenching action based at least partially on the calculated quenching load profile, wherein starting the quenching action comprises disposing an amount of liquid onto the amount of coke using one or more quench spray nozzles;

stopping a quenching action based at least partially on the calculated quenching load profile, wherein stopping the quenching action comprises discontinuing disposing an amount of liquid onto the amount of coke using one or more quench spray nozzles;

identifying one or more hot spots in the quenched coke by scanning the quenched coke to identify hot spots;

adjusting the quench tower profile based on one or more of the identified hot spots.

[c70] 70. The method of claim 69, wherein starting the quenching action comprises automatically disposing the amount of liquid onto the amount of coke if the quenching action is not started within a predetermined amount of time after the train car enters the quench tower.

[c71] 71. The method of claim 69, wherein the starting a quenching action and stopping the quenching action are based on the received one or more quenching parameters.

[c72] 72. The method of claim 69, wherein the scanning is performed by an infrared camera system or a thermocouple array.

[c73] 73. The method of claim 69, further comprising transporting the train car out of the quench tower, wherein the train car is transported through an opening in the quench tower.

[c74] 74. The method of claim 73, wherein the train car is received through a first opening and transported out of a second opening.

[c75] 75. The method of claim 74, wherein the first opening and the second opening are the same or different.

[c76] 76. The method of claim 74, wherein at least one of the first opening or the second opening is located in a front section of the quench tower, a back section of the quench tower, or a side section of the quench tower.

[c77] 77. The method of claim 74, wherein at least one of the first opening or the second opening contains a movable barrier coupled thereto that at least partially covers the opening.

[c78] 78. The method of claim 77, wherein the movable barrier is a door or curtain.

[c79] 79. The method of claim 69, wherein at least one of the one or more quench spray nozzles begins disposing an amount of liquid onto the amount of coke before a different at least one of the one or more quench spray nozzles begins disposing an amount of liquid onto the amount of coke.

[c80] 80. The method of claim 69, wherein at least one of the one or more quench spray nozzles stops disposing an amount of liquid onto the amount of coke before a different at least one of the one or more quench spray nozzles stops disposing an amount of liquid onto the amount of coke.

[c81] 81. The method of claim 69, wherein at least one of the one or more quench spray nozzles disposes an amount of liquid onto a center area of the mass of coke to be quenched.

[c82] 82. The method of claim 69, wherein at least one of the one or more quench spray nozzles disposes an amount of liquid onto an area that is not a center area of the mass of coke to be quenched.

[c83] 83. The method of claim 69, wherein the at least one of the one or more quench spray nozzles is mounted above the quench tower.

[c84] 84. The method of claim 69, wherein the one or more quenching parameters is an oven number, a coke tonnage, or a coke size.

[c85] 85. The method of claim 69, further comprising performing a secondary quenching action to quench at least one of the one or more identified hot spots, wherein performing the secondary quenching action comprises disposing an amount of liquid onto the identified hot spots for a period of time using one or more quench cannons.

[c86] 86. The method of claim 69, further comprising performing a secondary quenching action to quench at least one of the one or more identified hot spots, wherein performing the secondary quenching action comprises disposing an amount of liquid onto the identified hot spots for a period of time using one or more spray nozzles located inside of a shed of the quench tower, the shed being attached to the quench tower in order to expand the quench tower effective perimeter area.

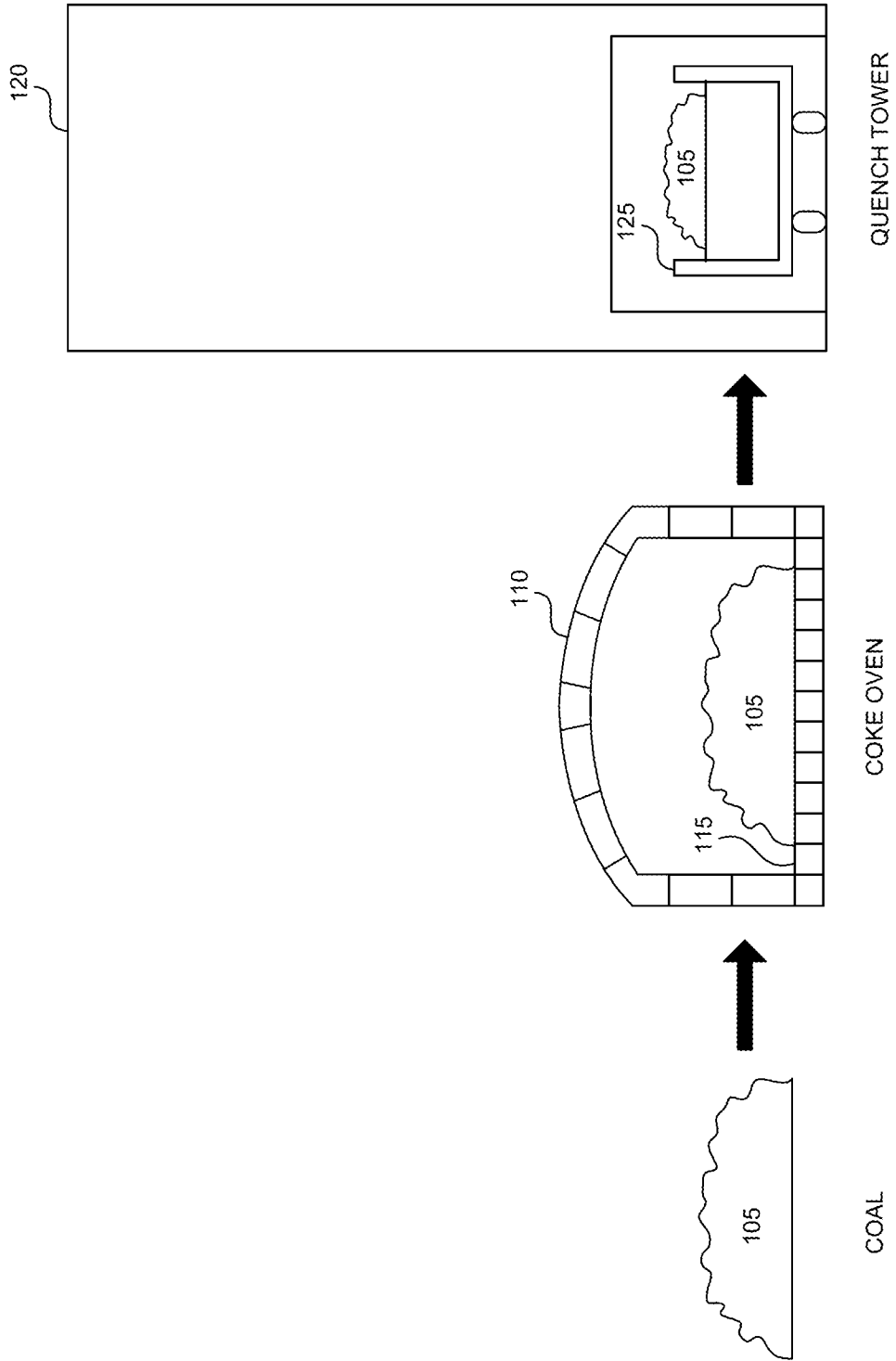

FIG. 1

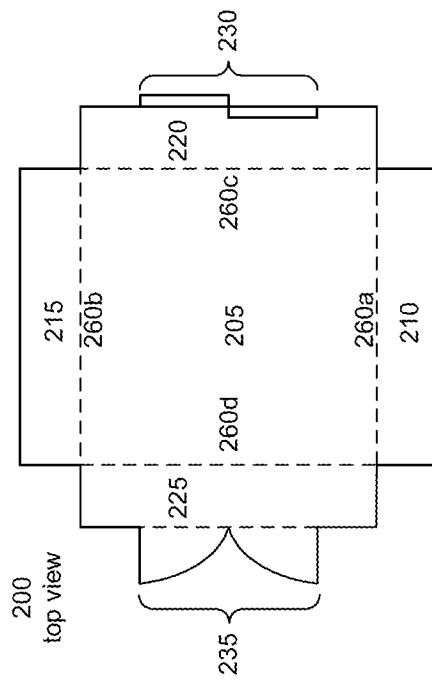

FIG. 2A

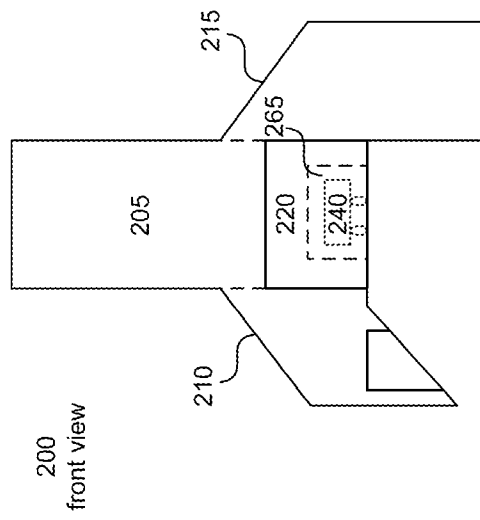

FIG. 2B

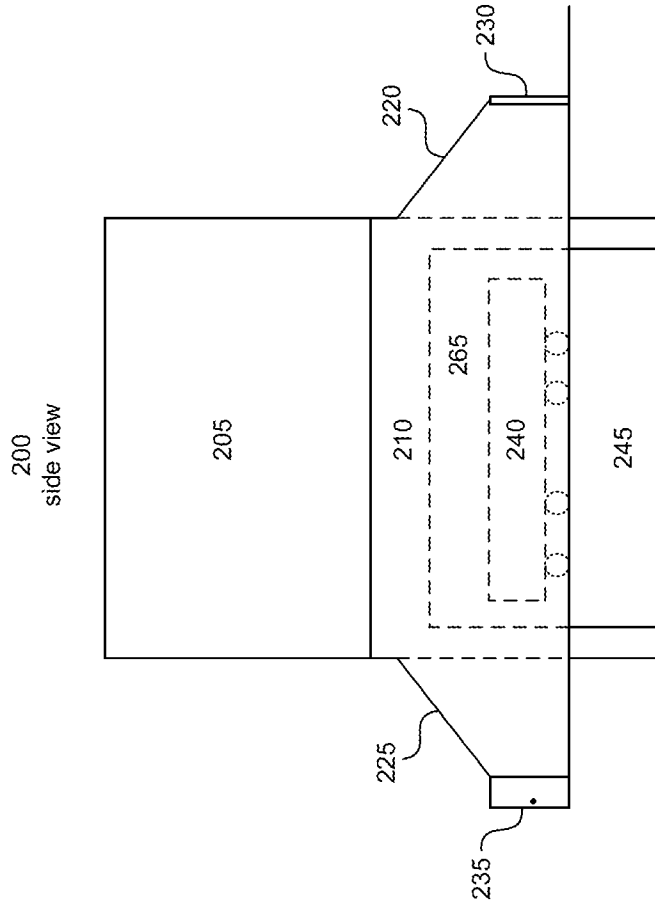

FIG. 2C

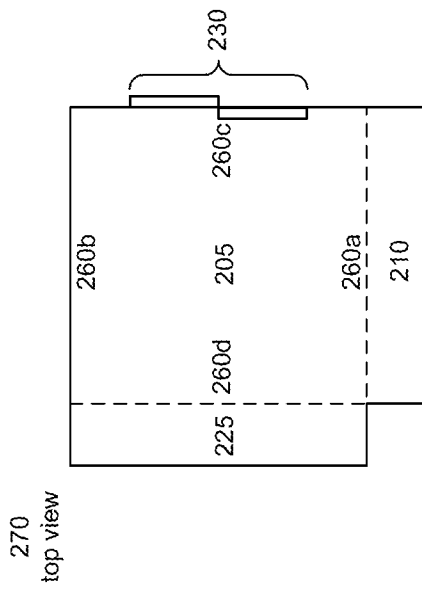

FIG. 2D

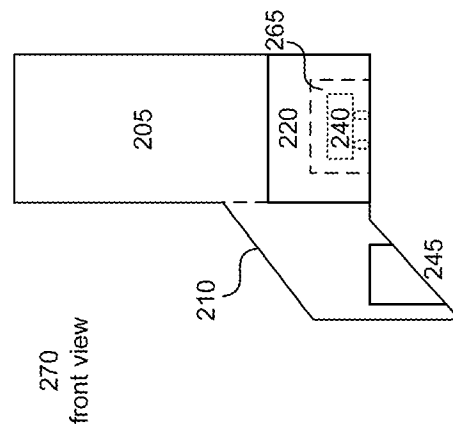

FIG. 2E

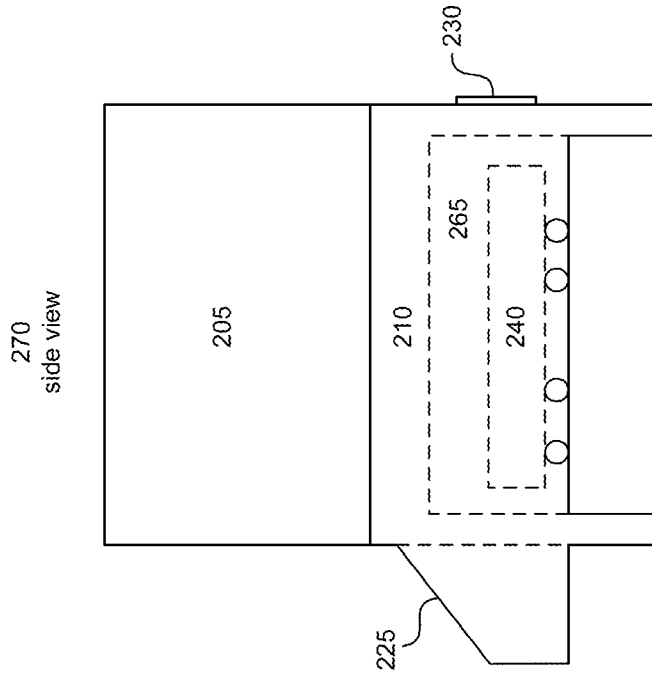

FIG. 2F

4/8

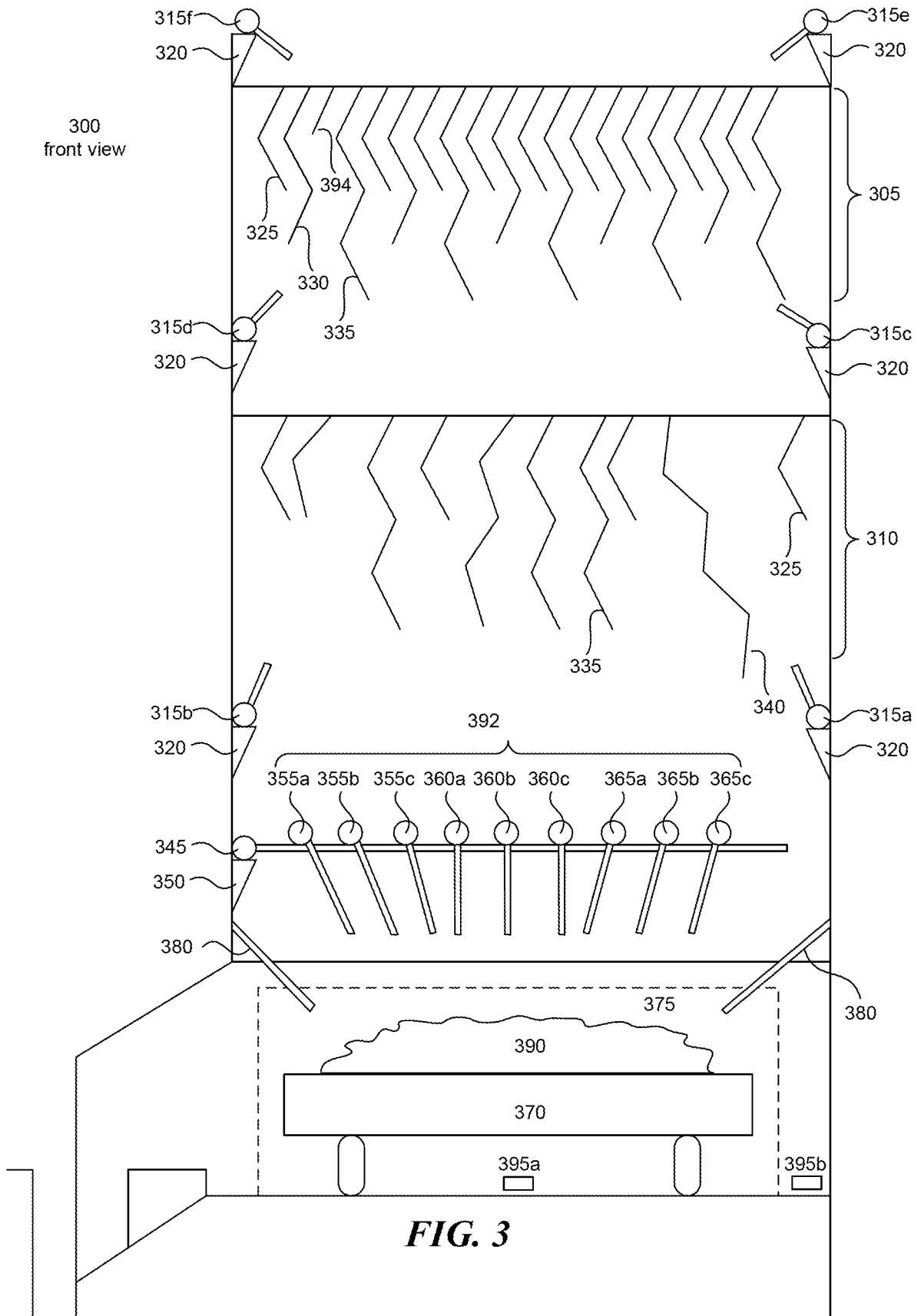

FIG. 3

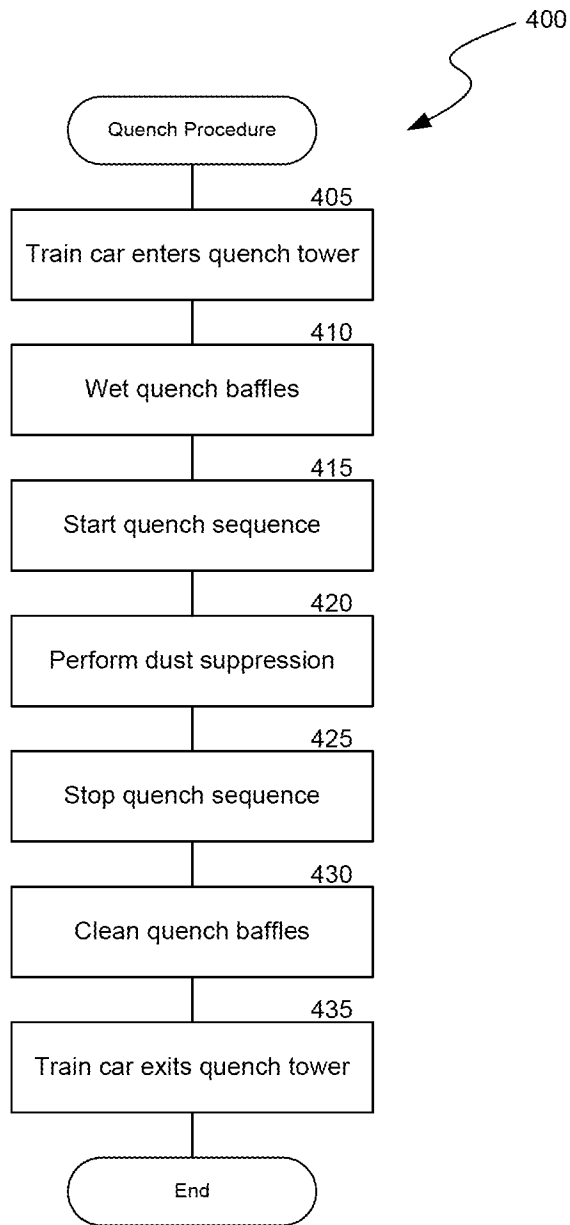

FIG. 4

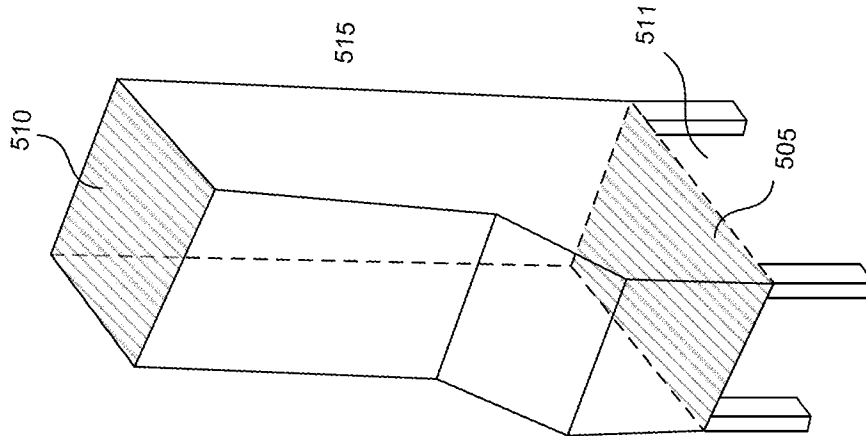

FIG. 5A

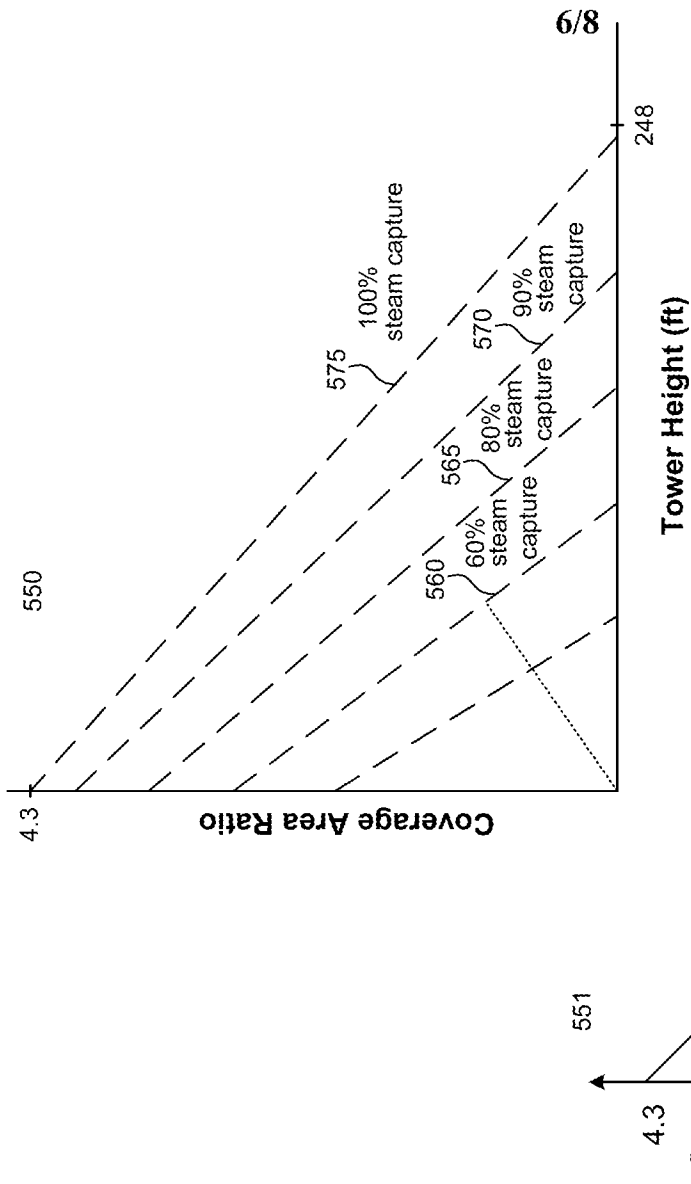

FIG. 5B

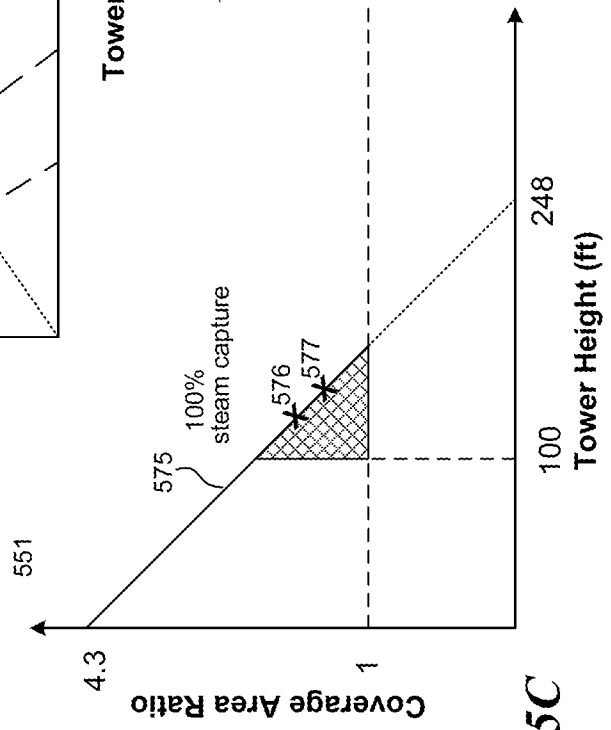

FIG. 5C

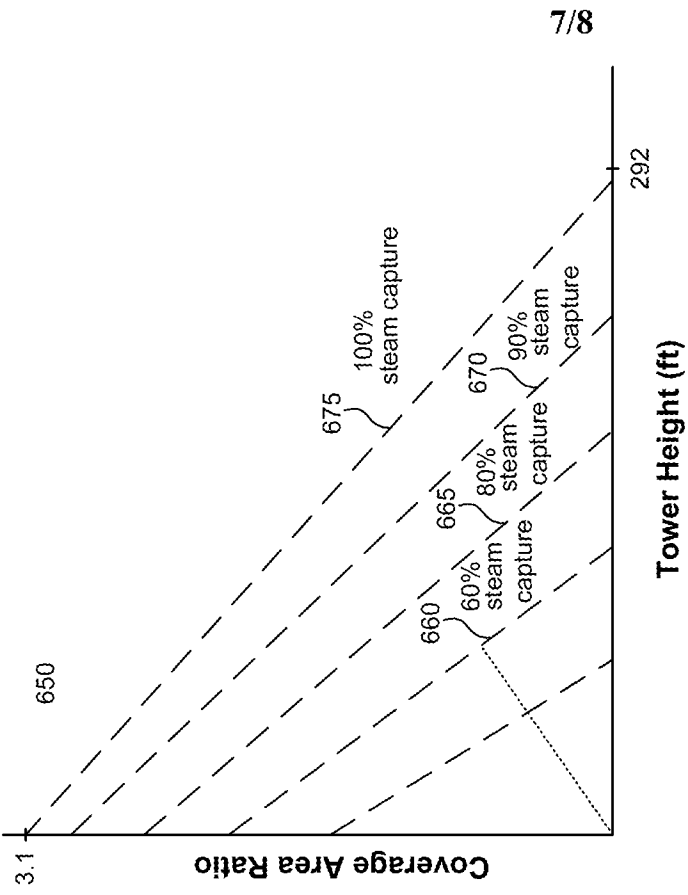

FIG. 6B

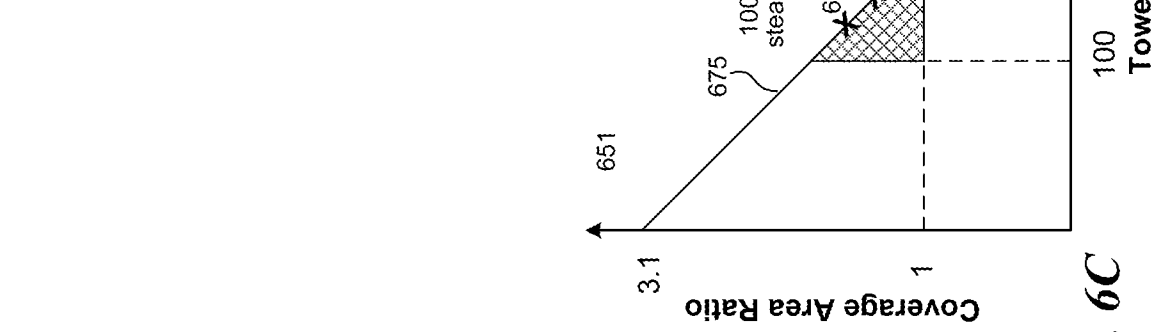

FIG. 6C

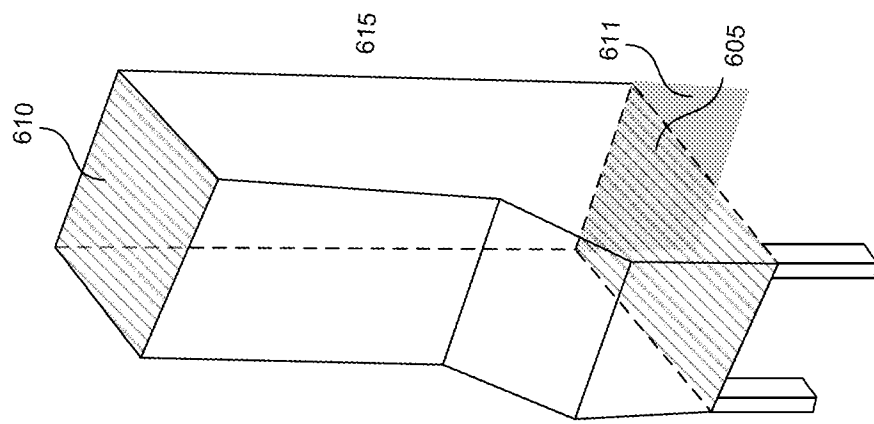

FIG. 6A

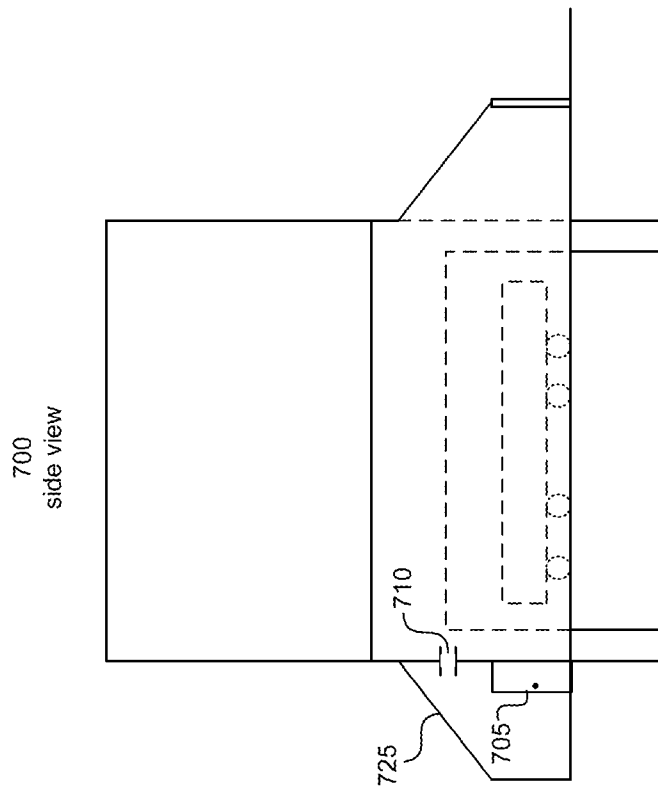

FIG. 7

A. CLASSIFICATION OF SUBJECT MATTER**C10B 39/08(2006.01)i, C10B 39/12(2006.01)i**

According to International Patent Classification (IPC) or to both national classification and IPC

B. FIELDS SEARCHED

Minimum documentation searched (classification system followed by classification symbols)

C10B 39/08; C10B 39/12; C10B 39/06; G01J 5/00; C10B 27/00; C01B 39/08; C10B 39/10; C10B 39/04; C10B 39/14

Documentation searched other than minimum documentation to the extent that such documents are included in the fields searched

Korean utility models and applications for utility models

Japanese utility models and applications for utility models

Electronic data base consulted during the international search (name of data base and, where practicable, search terms used)

eKOMPASS(KIPO internal) & Keywords: quench tower, shed, physical perimeter, baffle, chevron, hot spot

C. DOCUMENTS CONSIDERED TO BE RELEVANT

Category*	Citation of document, with indication, where appropriate, of the relevant passages	Relevant to claim No.
A	US 2012-0228115 A1 (WESTBROOK, R.) 13 September 2012 See abstract; paragraphs [0004], [0039]-[0041], [0053], [0055] and figures 5, 13.	1-86
A	KR 10-1999-0054426 A (POHANG IRON & STEEL CO., LTD.) 15 July 1999 See abstract; and pages 2, 3.	1-86
A	US 4263099 A (PORTER, R. W.) 21 April 1981 See abstract; claims 1, 5; column 4, lines 20-39; and figure 1.	1-86
A	US 4289585 A (WAGENER, D. et al.) 15 September 1981 See abstract; and figure 3.	1-86
A	US 2012-0024688 A1 (BARKDOLL, M. P.) 02 February 2012 See abstract; paragraphs [0006]-[0008], [0052]; and figures 2, 3.	1-86
A	US 4614567 A (STAHLHERM, D. et al.) 30 September 1986 See abstract; and columns 1-3.	1-86
A	US 3930961 A (SUSTARSIC, J. D. et al.) 06 January 1976 See abstract; columns 1-2; and figures 1, 2.	1-86

 Further documents are listed in the continuation of Box C. See patent family annex.

* Special categories of cited documents:

"A" document defining the general state of the art which is not considered to be of particular relevance

"E" earlier application or patent but published on or after the international filing date

"L" document which may throw doubts on priority claim(s) or which is cited to establish the publication date of another citation or other special reason (as specified)

"O" document referring to an oral disclosure, use, exhibition or other means

"P" document published prior to the international filing date but later than the priority date claimed

"T" later document published after the international filing date or priority date and not in conflict with the application but cited to understand the principle or theory underlying the invention

"X" document of particular relevance; the claimed invention cannot be considered novel or cannot be considered to involve an inventive step when the document is taken alone

"Y" document of particular relevance; the claimed invention cannot be considered to involve an inventive step when the document is combined with one or more other such documents, such combination being obvious to a person skilled in the art

"&" document member of the same patent family

Date of the actual completion of the international search

08 July 2014 (08.07.2014)

Date of mailing of the international search report

10 July 2014 (10.07.2014)

Name and mailing address of the ISA/KR

International Application Division
Korean Intellectual Property Office
189 Cheongsu-ro, Seo-gu, Daejeon Metropolitan City, 302-701,
Republic of Korea

Facsimile No. +82-42-472-7140

Authorized officer

LEE, Dong Wook

Telephone No. +82-42-481-8163



INTERNATIONAL SEARCH REPORT

Information on patent family members

International application No.

PCT/US2014/028437

Patent document cited in search report	Publication date	Patent family member(s)	Publication date
US 2012-0228115 A1	13/09/2012	US 2011-284360 A1 US 8236142 B2 US 8394242 B2	24/11/2011 07/08/2012 12/03/2013
KR 10-1999-0054426 A	15/07/1999	KR 10-0317962 B1	08/03/2002
US 04263099 A	21/04/1981	None	
US 04289585 A	15/09/1981	JP 55-137187 A US 04322269 A	25/10/1980 30/03/1982
US 2012-0024688 A1	02/02/2012	AU 2010-226332 A1 CA 2754737 A1 CN 102597170 A EP 2408877 A1 JP 2012-520922 A KR 10-2011-0129478 A RU 2011141587 A US 2010-236914 A1 US 7998316 B2 WO 2010-107513 A1	03/11/2011 23/09/2010 18/07/2012 25/01/2012 10/09/2012 01/12/2011 27/04/2013 23/09/2010 16/08/2011 23/09/2010
US 04614567 A	30/09/1986	EP 0160082 A1 WO 85-01953 A1	06/11/1985 09/05/1985
US 03930961 A	06/01/1976	JP 50-138002 A	04/11/1975