

(19)
(12)

(KR)
(A)

(51) 。 Int. Cl. 7
H01R 12/16

(11)
(43)

2002 - 0096088
2002 12 31

(21) 10 - 2001 - 0034131
(22) 2001 06 16

(71) 726 - 3

(72) 1843 405 501

(74)
:

(54)

, 가

;

가

가

, .

,

2

1

7

, , , 가 ,

1

2

3

4

5

6

7

8

9 8 " A - A"

10 8 " A - A"

11 8 " B - B"

12

13

14

**

**

100. 110.

112. 114.

120. - 130.가

132.가 200.

210. 212,

214. 220.

222. 224.

230. 232.

234. 가 240.

300. 310.
320.

(Connector) , (PCB; Printed
Circuit Board) ,
(FFC; Flexible Flat Cable) 가 (FPC) 가
1 , 2 , 4
1 4 (20) (10)
(12, 14) (14) (14)
(30) (32) (20) (26)
(10) (16) 가 (18) (20) (22) (24)
(14) (14a) () (20)
(14) (20) (26)가 (14)
(30) (34) (32) (32a)
(14) (14) (20) (30)
(14) 가 (12) , (12, 14)
(24)가 (10) (20) (22) (24a)
(20) (24a) (26)가 (26)
(40)가 (14) (24) (14a) (20)
(24) (26)

가

가

가 가 . ,
가 .

가 . ,

가 . ,
가 가 .

가

가

1
2 가

가

(222) (230) (300) (310)
 (230) 가 . , .

(210) (200) (210)
 (230) 가 (234) .

(210) (100) - (120) 가 (130)
 (210) (230) 가 (234) 가
 (130) (132) .

(210) (200) (110) (114)
 (114) ()가 (212) . , 가
 (200) (114)

(220) (114) (114a)
 (220) (230) (222) .

(114) (220) (210) (220)
 (224)가 (300) (320) .

(220) (114) (114a)
 (112, 114) (110) (220)

(114a) (240) .

(220) (210) (240) (214)
 (214) (240) (114) (114a) (214)
 (220) , (114a) (220) (110) (114a)

가

(230) (100) - (120) 가 (130) (132)
 (114) (300) (310) ,
 (230) (114) (300) (310)
 (130) (132) (232) 가 (100) - (120) 가
 (234) .

(230) 가 (234) (220) (222)
 (222) (236) .

1 (230) (220) (222)
 (230)가 (220) (210)

2 (220) (210)
 (222) (222)

(222) (230) (230) 가
 (234) (210) . , .

, (230) (232) (300) (310) 가 가
 (300) (310) (300) (310) (232) (230) (232) 가
 (232) (300) (310) (232)
 (300) (310) . , (230)
 (200) (100) (210) (120) (200) 가 (100) (130) (230)
 가 (210) (234) 가 (130) (132) (210) (230) (230)
 가 (130) (230) 가 (234) (240) ,
 (240) (200) (220) (214) (240) (114) ,
 (114a) (200) (220) (110) (114) (200)
 (114)
 14 , (114) (300) (224) (300) (300) (320) (1
 . (220)
 (114) (200) (300) (300) (114)
 (200) (230) (300) (114) .
 (300) (310) (200) (230) (232)
 , (200) (210) (230)가 , 6, 9 13
 (222) (220)
 1 , (220) (230)가 (222) (230) (210) 2
 . (230)가 (220) (210)
 210) 가 (220) (230) 1 (230)
 , (220) (210) 2 (210) 가 (220) (
 ()

(210) 2 (220) (230) 1 (220) , (220)
 (210) (220) (230)
 (210) . , .

가

가

가 .

1

2
가 .

(57)

1.

가

가

;

;

가

가

가

2.

1 ,

가

3.

1 2 ,

4.

· - 가 ,

,

1

2

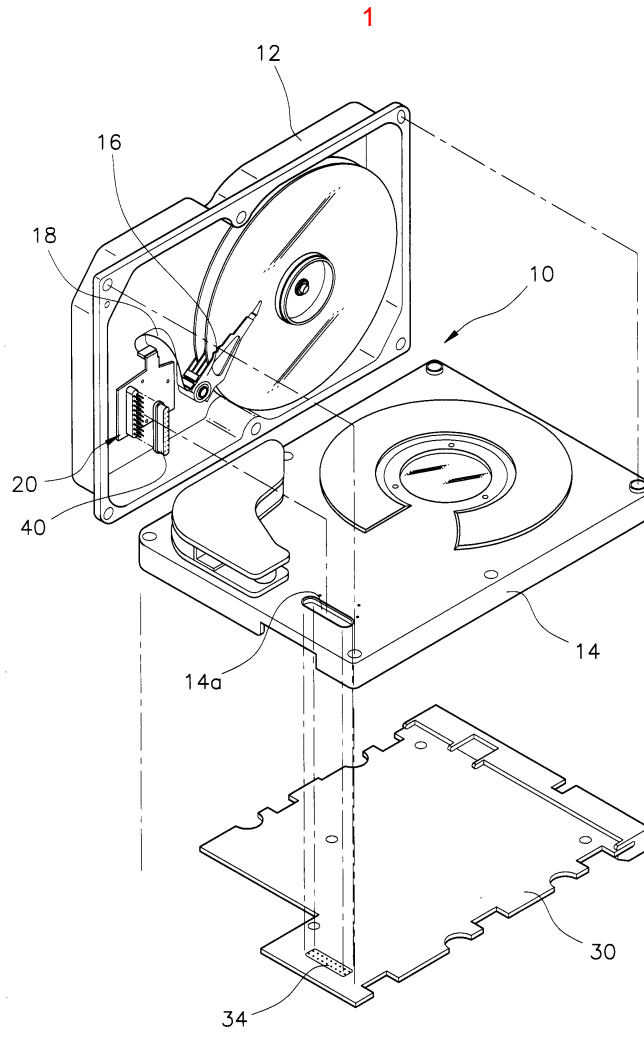

2

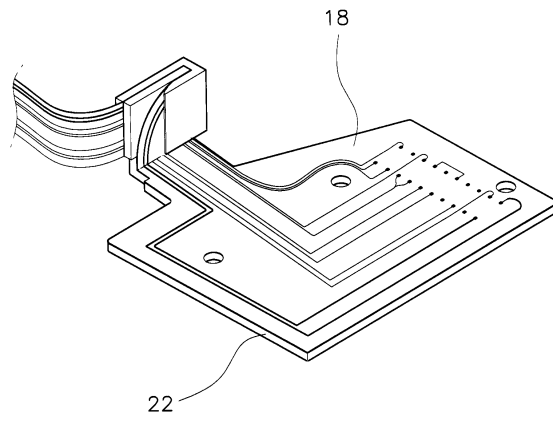

3

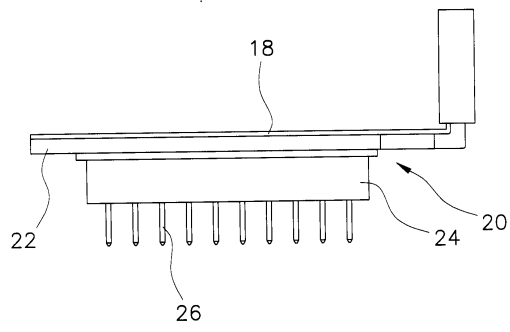

4

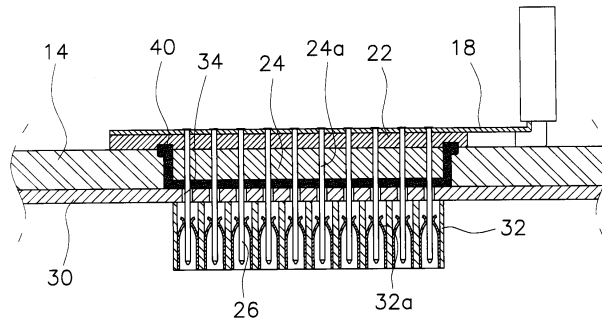

5

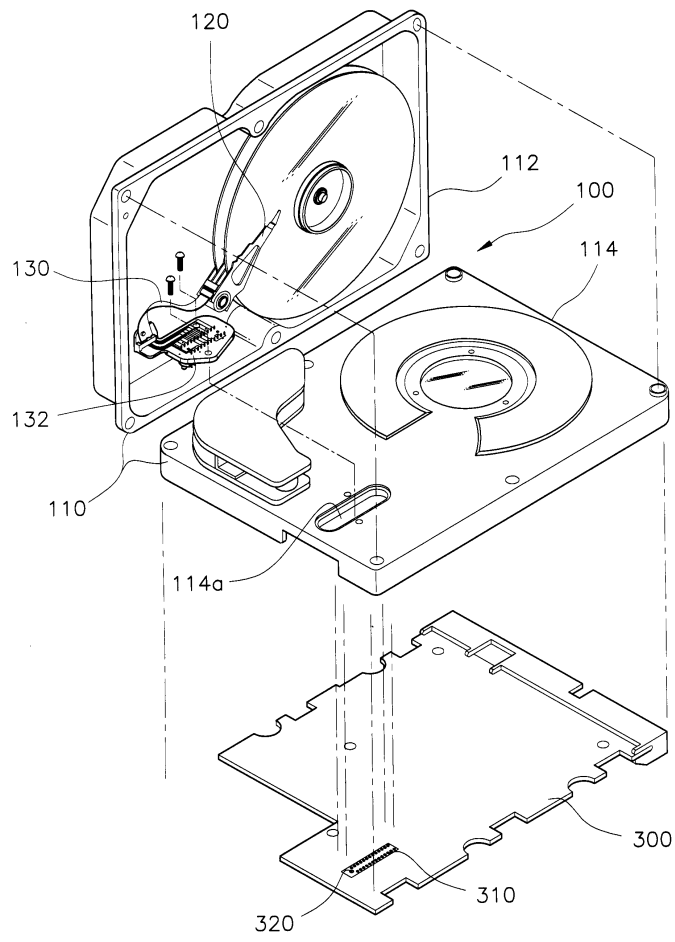

6

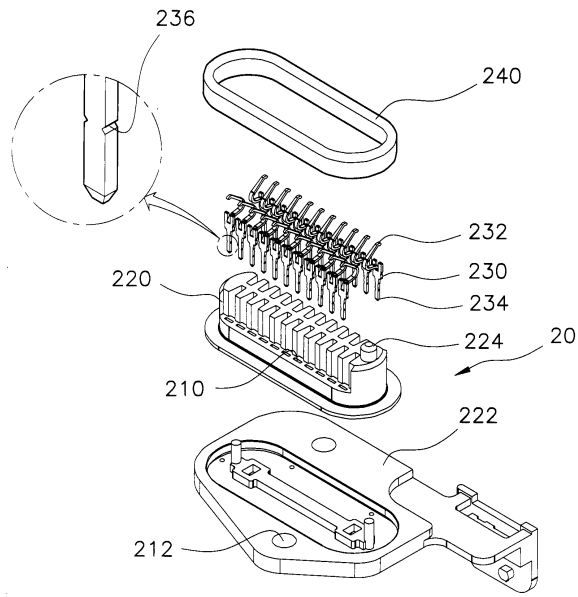

7

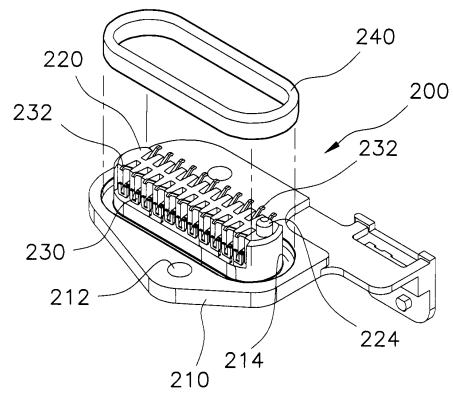

8

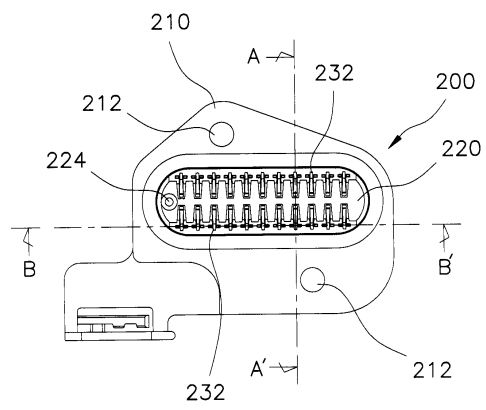

9

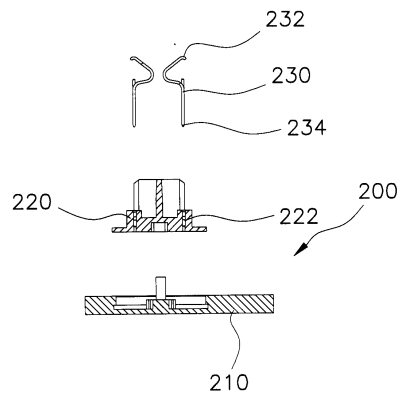

10

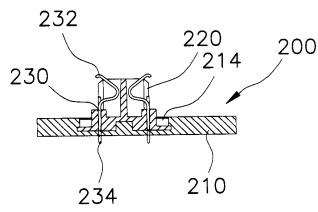

11

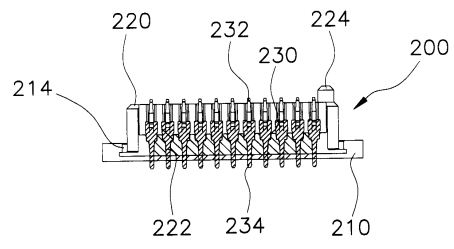

12

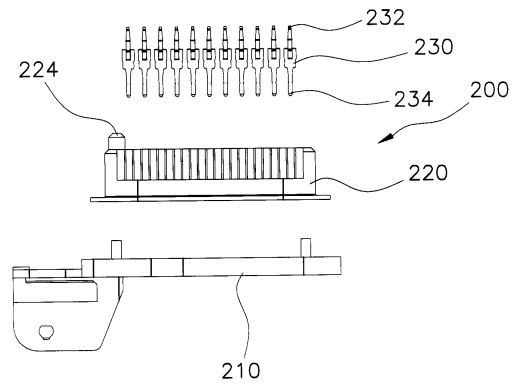

14

