

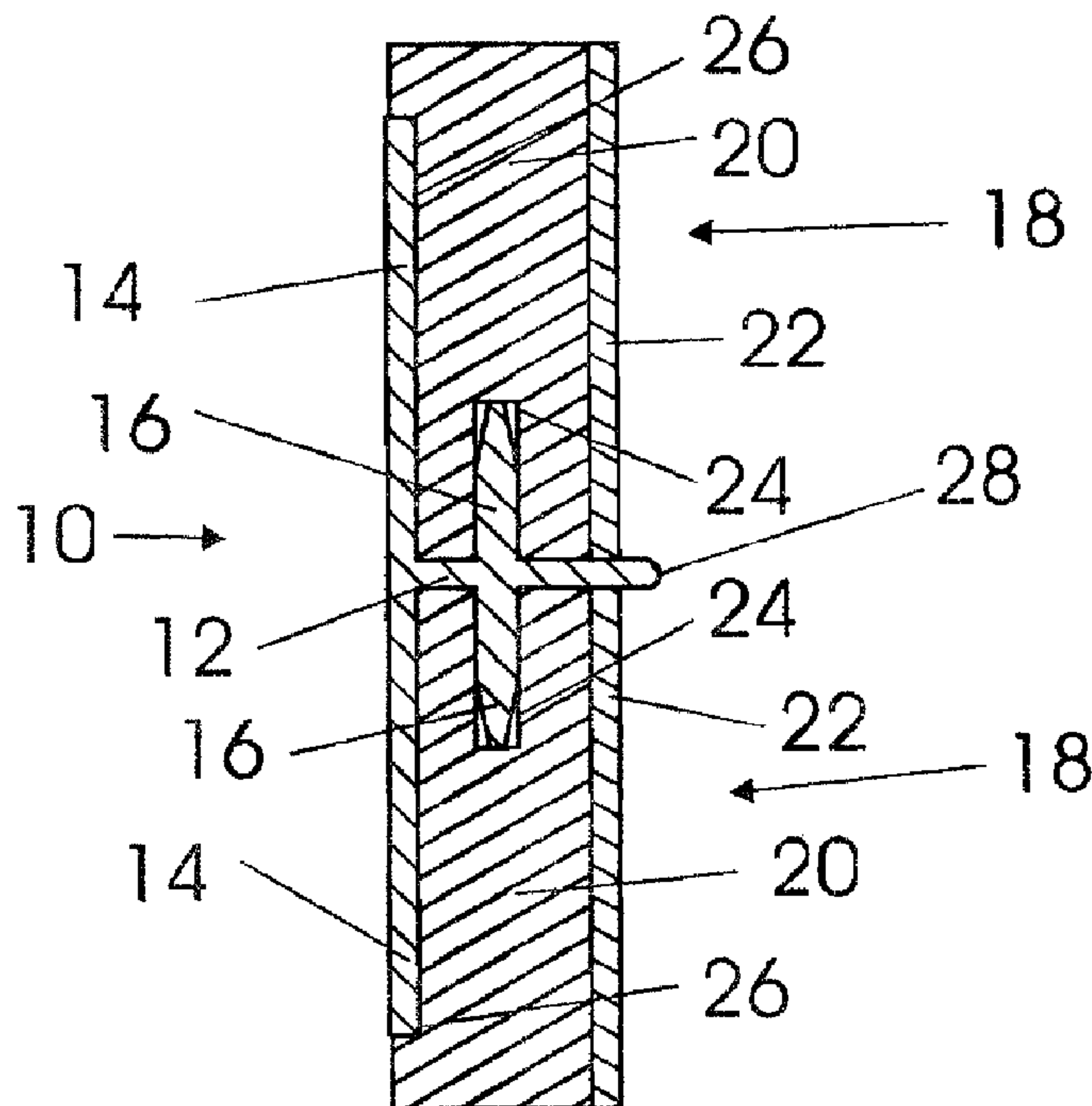

(22) Date de dépôt/Filing Date: 2003/10/17
 (41) Mise à la disp. pub./Open to Public Insp.: 2004/04/21
 (45) Date de délivrance/Issue Date: 2007/08/07
 (30) Priorité/Priority: 2002/10/21 (US60/419,523)

(51) Cl.Int./Int.Cl. *E04B 1/61* (2006.01),
B66B 11/02 (2006.01), *E04B 2/00* (2006.01),
E04B 5/00 (2006.01), *E04C 2/40* (2006.01),
E04F 13/08 (2006.01), *E04F 15/02* (2006.01)
 (72) Inventeur/Inventor:
 GRIMES, PHILIP R., CA
 (73) Propriétaire/Owner:
 718013 ONTARIO LTD., CA
 (74) Agent: MACRAE & CO.

(54) Titre : SYSTEME D'ENCASTREMENT PAR PANNEAUX
 (54) Title: PANEL FITMENT SYSTEM



(57) **Abrégé/Abstract:**

The invention provides a paneling system primarily for elevator cabs, utilizing a plurality of decorative panels each of which is provided with a kerf extending into the panel from at least one edge thereof and a rabbet portion cut into a rear surface from the same edge as contains the kerf. A fitment member has a central web portion, a pair of rearmost flanges extending laterally from one end of the web portion and a pair of second flanges extending laterally from the web portion but spaced from the rearmost flanges. One of the second flanges will have tight fit in a kerf of one panel while a corresponding rearmost flange will fit within the rabbet portion of that panel. A second panel can then be registered with the other rearmost and second flanges of the fitment member, joining or interlocking the two panels together. The web portion can have its outer end flush with the outer surfaces of the panels or projecting therebeyond. The rearmost flanges can have countersunk holes therethrough for the use of flat headed screws to secure the flanges to a panel and to a wall or other surface to which the panels are to be mounted.

ABSTRACT

The invention provides a paneling system primarily for elevator cabs, utilizing a plurality of decorative panels each of which is provided with a kerf extending into the panel from at least one edge thereof and a rabbet portion cut into a rear surface from
5 the same edge as contains the kerf. A fitment member has a central web portion, a pair of rearmost flanges extending laterally from one end of the web portion and a pair of second flanges extending laterally from the web portion but spaced from the rearmost flanges. One of the second flanges will have tight fit in a kerf of one panel while a corresponding rearmost flange will fit within the rabbet portion of that panel.
10 A second panel can then be registered with the other rearmost and second flanges of the fitment member, joining or interlocking the two panels together. The web portion can have its outer end flush with the outer surfaces of the panels or projecting therebeyond. The rearmost flanges can have countersunk holes therethrough for the use of flat headed screws to secure the flanges to a panel and to a wall or other surface
15 to which the panels are to be mounted.

PANEL FITMENT SYSTEM

FIELD OF THE INVENTION

5 This invention relates to a panel fitment or interlock system for interlocking panels or sheet material into a covering for a wall. The system finds particular use in the renovation of elevator cabs when it is desired to cover existing wall surfaces during refurbishment of older cabs.

BACKGROUND OF THE INVENTION

10 When retrofitting or refurbishing elevator cabs it is not possible, in most instances, to place new panels of wall covering material within the cab as a single sheet, capable of covering an entire wall. It is not possible to move an entire wall-covering sheet through the elevator doors and hence it is necessary to effect the covering by means of a plurality of sheets cut to fit the wall to be covered, which
15 sheets must be joined along abutting edges. The panels will not exhibit much flexibility and they will have a substantial weight which must be borne by whatever fastening system is available. Different fastening systems have been proposed, including those found in PCT publication WO01/43607 and US Patent No. 6,101,778. These systems exhibit drawbacks in production and utilization making them undesirable for efficient
20 and economical retrofitting of elevator cabs.

SUMMARY OF THE INVENTION

The system of the present invention overcomes the problems of the prior art by utilizing an interlock or fitment member that is preferably extruded from aluminum,
25 with a rather simple cross-section, the member fitting with corresponding recesses or cut-outs in the panels to be applied to a supporting surface, such as the wall of an elevator cab. The member has a generally T-shape with a pair of first or rearmost flanges extending laterally from a central web portion, the web portion being perpendicular to the rearmost flanges. A second set of flanges extend laterally from
30 the central web and are spaced from the rearmost flanges. The interlock member strengthens the joint between the panels by having one of the second flanges being received in a kerf cut in an adjacent edge of the panel. Optionally, one of the rearmost flanges can be fastened to the panel as by adhesive or removable fasteners such as a plurality of screws. Each rearmost flange of the member fits into a cut-out rabbet

portion of the rear face of the panel.

In another embodiment of the invention the fitment member is utilized with thin aluminum panels preferably carrying a decorative covering thereon. The connection between the fitment member and each panel is accomplished by way of an H-shaped extruded spacer. Two parallel legs of the spacer define a kerf that has a tight fit with the second flanges of the fitment member. The other two parallel legs of the spacer have through holes therein to receive appropriate fasteners to fix the spacer to the rearmost flange of the fitment member and to the panel itself, respectively. For additional strength, if needed, a plurality of channel members can be adhered or fastened to the rear surface of the panel extending normal to and between the fitment members. This embodiment of the invention will be lighter in weight than the first embodiment of the invention which utilizes solid core panels.

Generally speaking therefore the present invention may be considered as providing a panelling system for covering a substrate with a plurality of panels, the system comprising at least two panels adapted for fitment together along adjacent edges thereof and a fitment member adapted for connection to the at least two panels; each panel having a panel body, an outer surface, an inner surface and a plurality of edges, a kerf extending into the panel body between the inner and the outer surfaces from at least one of the panel edges, and a rabbet portion extending into the panel body at the inner surface from the at least one panel edge; and the fitment member including a central web portion, a pair of first flanges extending laterally from the web portion and adapted for a tight fit in a respective panel kerf, and a pair of second flanges extending from one end of the web portion and adapted for a flush fit in a respective rabbet portion of a panel, one of the second flanges of each fitment member including means for securing that fitment member to the panel associated therewith and the other of the second flanges including means for securing the fitment member to the substrate to be covered, whereby with the at least two panels engaging the fitment member along the respective at least one panel edges, the panels will be spaced from each other by the thickness of the fitment member web portion and the panels will be interconnected by way of the first and second flanges engaging the respective kerfs and rabbet portions.

The invention may also be considered as providing a fitment member for use in a panelling system to interconnect at least two panels together along adjacent edges thereof, the fitment member comprising an elongated central web portion, a pair of

5 first flanges extending laterally from the web portion intermediate the ends thereof and along the length thereof, and a pair of second flanges extending from one end of the web portion, each of the second flanges being sized for mating reception in a corresponding rabbet portion formed in an inner surface of a panel along the edge thereof, one of the second flanges of each fitment member including means for securing that fitment member to the panel associated therewith and the other of the second flanges including means for securing the fitment member to a substrate to be covered, whereby in use a connecting portion of each panel will be tightly engaged

by the first and second flanges on each side of the web portion such that the panels will be spaced apart by the thickness of the web portion.

BRIEF DESCRIPTION OF THE DRAWINGS

5 The invention will be described in greater detail with reference to the drawings wherein:

 Fig. 1 is a cross-sectional view of an interlock or fitment member in accordance with this invention;

10 Fig. 2 is a cross-sectional view showing one embodiment of the fitment member in position between a pair of panels for fitting to a supporting surface; and

 Fig. 3 is a cross-sectional view of a panel used with this interlock or fitment system illustrating the cut-outs that co-operate with the interlock member.

 Fig. 4 is a view similar to Fig. 2 showing the use of a second embodiment of the fitment member of this invention.

15 Fig. 5 is a cross-sectional view of a panel member having a decorative cap in accordance with this invention extending along one edge thereof.

 Fig. 6 is an enlarged partial cross-sectional view of a fitment member of this invention showing the arrangement of countersunk through holes for attachment of the fitment member to a panel and to a wall.

20 Fig. 7 is a cross-sectional view of another embodiment of the paneling system of the invention utilizing the fitment member with a set of light-weight panels.

 Fig. 8 is a cross-sectional view of a spacer member that is used with the embodiment of Fig. 7.

25 Fig. 9 is a rear elevational view of a panel as used with the embodiment of Fig. 7.

 Fig. 10 is an enlarged partial cross-sectional view of a panel with a strengthening channel member connected thereto.

DESCRIPTION OF THE PREFERRED EMBODIMENTS

30 Fig. 1 shows in cross-section an interlock or fitment member 10 that is at the heart of the present invention. The member 10 would typically be extruded from aluminum to have the indicated cross-section and thus would be an integral piece of the desired length. It should be understood that the length of the member will be determined by the particular application with which it is to be utilized and that each

member will likely be cut from an extrusion that is originally longer than the required length. While the member is preferably extruded from aluminum it could also be extruded from a suitable plastics material, especially if the possibility of fire is not something that has to be considered in the particular application.

5 The member 10 is seen as including a central web portion 12 from which extends a pair of first or rearmost flanges 14, giving the member a generally T-shape. A pair of second, shorter, flanges 16 extends laterally and oppositely from the central web portion 12, spaced from the rearmost flanges and generally parallel thereto. Preferably the outermost ends of the second flanges 16 are slightly tapered as seen in
10 Fig. 1.

 Fig. 3 illustrates in cross-section a panel 18 that would be used with the interlock or fitment member 10. The panel 18 will include a core 20, likely of a particle board, MDF (medium density fiberboard) or similar material, likely treated to be fire retardant. The panel will also likely include a thin decorative outer layer 22 of a different material,
15 giving the panel when in place a particularly attractive appearance.

 Usually, but not exclusively, a panel 18 will be positioned such that its longest edges are parallel to the floor of the elevator cab. The upper and lower edges of the panel will be cut so as to be provided with a recess or kerf 24 extending the full length of the panel edge. The kerf 24 is sized to receive a second flange 16 of a fitment
20 member 10 in an interference fit therewith. Along the rear face of the panel 18 adjacent the edge containing the kerf 24 there is provided a rabbet or rectangular cut-out 26 sized to mate with one of the rearmost flanges 14 of the fitment member. The kerf and rabbet portion formed in this solid core panel may be considered as a connecting portion for the panel

25 Turning now to Fig. 2 the manner in which the fitment member 10 is interlocked with a pair of panels 18 is shown. The fitment member 10 is first of all fitted with the lowermost panel by sliding the lower second flange 16 into the kerf 24, the rearmost flange 14 being matingly received within the rabbet 26. Depending on the weight of the panels this interlocking fitment of the fitment member 10 with the lowermost panel
30 might be sufficient to lock the panel and the member together. If additional strength at the joint is required then it would be possible to utilize a suitable adhesive within the kerf 24 and the rabbet 26 which, when set, will prevent the fitment member from parting company from the panel during assembly of an entire wall. Other fastening means, including screws, rivets, staples, etc. might be used in place of an adhesive.

Once the fitment member has been secured to a lower panel, the panel with the fitment member in place is brought into abutment with a supporting surface and secured thereagainst, as by screws or other fastening means extending through the upper of the rearmost flanges (see Fig. 6). Once the lower panel is in position an upper panel 18 is brought into registry with the exposed upper portions of the fitment member, the kerf 24 in the lower edge of the upper panel mating with the upper second flange 16 of the fitment member. Since the upper panel will be resting on the fitment member, as on the central web thereof, it is not essential that it be specifically adhered to the fitment member. Another fitment member will be applied to the upper edge of the upper panel and secured to the supporting surface, as was done with the first panel.

This assembly process continues until a desired height of panels is achieved. The remaining fitment member is then "capped off" with a decorative topmost panel or left visible, depending on the desired decorative effect.

The fitment member shown in Fig. 1 has a flat free end to the central web. This is more clearly illustrated by the surface 30 as seen in Fig. 4. The web would be the same height as the distance from the rabbet 26 to the outer surface of the panel such that the end surface 30 of the central web would be flush with the panel surface. The flat free end could be finished so that it blends in with the decorative surface of the panels, giving the finished wall a continuous uninterrupted appearance. Alternatively, the end face could carry a finish which contrasts with the surface 22, giving the appearance of a decorative accent line between adjacent panels. The same effect could be obtained by providing the free end of the central web with an arcuate or ribbed end surface 28, as seen in Fig. 2. In this case the end surface 28 projects slightly from the panel surfaces 22, giving the wall added detail and depth to a surface which would otherwise be completely flat.

As indicated above, the fitment member can be secured to a panel by the use of threaded screws in addition to or in place of a suitable adhesive. Fig. 6 shows an enlarged cross-section of the first flanges 14 of a fitment member, wherein it is seen that each of the flanges is provided with a countersunk through hole extending therethrough. One of the flanges, the one to be mated with the lower panel of Fig. 2, has the countersunk hole 36 extending through the flange 14 from the back surface, so that a flat headed screw can be driven through the hole 36 into the panel body, with the screw head being flush with the back surface of the flange. The other flange has

a countersunk hole 38 extending through the flange from the inner or front surface of the flange so that a flat headed screw can be driven through the hole 38 into the supporting wall to which the paneling system is to be attached. The holes 36 and 38 would be spaced apart along the length of the fitment member.

5 Also as indicated above it is possible to "cap off" the paneling system with a decorative panel section custom fit to mate with the uppermost panel and to fill in any gap between the uppermost panel and a ceiling. It is also possible to "cap off" an uppermost, or any other panel, with a partial fitment member formed as a decorative cap member, as seen in Fig. 5. The cap member 32 has a single rearmost or first
10 flange 14 for mating with a rabbet portion of a panel and a single second flange 16 extending from the web portion 34 for fitment within a kerf 24 of a panel. In this embodiment of the fitment member the visible surface of the web portion 34 would have an attractive appearance so that it will act as a finishing piece for the paneling system.

15 Figures 7 to 10 illustrate yet another embodiment of the present invention, providing a attractive and light-weight paneling system based on the principles of the embodiments described above. With this system, shown by reference number 50, an extruded aluminum fitment member 52 having a central web portion and laterally extending flanges as with the fitment member 10 described above is used to
20 interconnect a pair of decorative panels 70. In this case the panels 70 are formed of thin aluminum (preferably) sheet and in turn are covered with a sheet 72 of decorative material. To connect the fitment member 52 and a panel 70 together there is provided a spacer member 54 shown in greater detail in Fig. 8.

25 The spacer member 54 has a cross-section that can be described as being H-shaped with one pair of parallel legs 57 extending in one direction from a central web portion 58 and a second pair of parallel legs 59 extending in an opposite direction from the central web portion 57. The legs 59 are thicker than the legs 57 and they define a kerf 56 therebetween, the kerf 56 being essentially the same size as a kerf 24 that would be provided in a solid panel as described above. A plurality of holes 60 and 62
30 spaced apart along the length of the spacer extend through the legs 57.

With reference to Fig. 7 it will be seen that a spacer member 54 is secured to a panel 70 along one edge thereof, as by way of a suitable adhesive and/or suitable fasteners extending through the panel and the through holes 60 in the spacer member. Preferably, the spacer member is affixed to the aluminum panel 70 before the

decorative covering 72 is applied to the outer surface of the panel. The spacer member 54 thus creates a connecting portion for a panel used in the present invention

5 With reference again to Fig. 7 it will be seen that a spacer 54 fits with a fitment member on each side of the central web portion thereof, with the first flanges of the fitment member being received within a kerf of the corresponding spacer member. The spacer member is dimensioned so that one flat surface thereof will lie on the upper surface of the rearmost flange of the fitment member, ensuring a tight fit between the spacer member and the fitment member. As shown, the through holes 62 of each spacer member will be aligned with corresponding through holes 64 in the rearmost flanges of the fitment member for reception of suitable fasteners such as machine screws or "pop" rivets. An adhesive can be placed between the spacer member and the rearmost flange to enhance the attachment of the spacer member to the fitment member.

15 Fig. 9 illustrates the rear of a panel 70 having a fitment member extending along each of the upper and lower edges thereof, only the rear surface 76 of each fitment member being visible. The fitment member 52 and the spacers 54 provide reasonable lengthwise strength to the panel. In order to reduce or eliminate flex or twisting of a panel prior to assembly to a substrate a plurality of channel members 78 can be affixed to the rear of the panel either by a suitable adhesive or by suitable fasteners such as machine screws or "pop" rivets extending through the panel and the bight of the channel member on the center line 80. Preferably a channel member will be affixed to a panel adjacent each end thereof, with the channel members extending normal to the fitment members. Strengthening channel members 78 are a desirable feature and do not add much weight to a panel; they are not illustrated in Fig. 7.

25 The paneling system of Figs. 7 to 10 is applied to a substrate in the same manner as the earlier described system. With reference to Fig. 7 a spacer member 54 is first of all secured to a panel 70 and the covering 72 is applied thereto. Then, a fitment member is secured to the uppermost spacer member 54 of the lowermost panel to be applied to a substrate, for example the spacer 54 shown to the left of the fitment member in Fig. 7. The panel with the fitment member extending along the upper edge thereof is placed against the substrate and suitable fasteners, such as flat headed screws are used to secure the fitment member to the substrate, by passing through the holes 64 in the upper, or right hand, rearmost flange of the fitment member. Then the next upper panel with a spacer member extending along the

lowermost edge of the panel 70 is lowered onto the fitment member along the upper edge of the lower panel so as to be interlocked therewith. Assembly continues in a vertical manner until an entire wall is created. Decorative caps can be provided to cover the uppermost fitment member or to fill in any gaps that might be left between the uppermost panel and a ceiling. Decorative angle strips can be positioned at each vertical end of a panel, if needed, to hide the end of the fitment member and the side edge of a channel member 78.

While the paneling system has been generally described with the fitment members of the invention extending horizontally between vertically adjacent panels it is clear that they can also extend vertically between horizontally extending panels. It would likely be necessary in instances where the vertical and horizontal fitment members are used to trim one or both members at any corner where they meet to ensure a clean appearance at such corners. It would also be possible to use the fitment members running at an angle to the vertical or the horizontal for a different visual effect, although the panels would have to be prepared appropriately to accommodate an angled appearance.

The system of the present invention is inexpensive to manufacture and simple to install. The ease of installation has the added bonus of reducing necessary downtime associated with elevator maintenance.

While the fitment system of the present invention was developed in association with elevator refurbishment it is clear that it could be used with original manufacture of elevator cabs and that it could also be used for any type of panel installation where the panels can be provided with edge kerfs and rabbets without seriously affecting the strength or other important properties of the panels.

CLAIMS:

1. A panelling system for covering a substrate with a plurality of panels, said system comprising at least two panels adapted for fitment together along adjacent edges thereof and a fitment member adapted for connection to at least said at least two panels;
- 5 each said panel having a panel body, an outer surface, an inner surface and a plurality of edges, a kerf extending into said panel body between said inner and said outer surfaces from at least one of said panel edges, and a rabbet portion extending into said panel body at said inner surface from said at least one panel edge; and
- 10 said fitment member including a central web portion, a pair of first flanges extending laterally from said web portion and adapted for a tight fit in a respective panel kerf, and a pair of second flanges extending from one end of said web portion and adapted for a flush fit in a respective rabbet portion of a panel;
- 15 one of said second flanges of each fitment member including means for securing that fitment member to the panel associated therewith and the other of said second flanges including means for securing said fitment member to the substrate to be covered;
- 20 whereby with said at least two panels engaging said fitment member along the respective at least one panel edges, said panels will be spaced from each other by the thickness of said fitment member web portion and said panels will be interconnected by way of said first and second flanges engaging the respective kerfs and rabbet portions.
- 25 2. The system of claim 1 wherein each of said first flanges decreases in thickness towards the outer end thereof to facilitate entrance of the first flange into a corresponding kerf.
- 30 3. The system of claim 1 wherein each of said securing means comprises a plurality of apertures extending through the respective second flange for reception of fastening means adapted to secure said fitment member to the panel or to the substrate.
4. The system of claim 1 wherein each of said securing means comprises a plurality of countersunk apertures extending through the respective second flange for reception

of corresponding flat-head screws, with the apertures of one of said second flanges being oriented opposite to the apertures of the other of said second flanges, whereby one set of said screws can be utilized to secure said fitment member to one of said panels and another set of screws can be utilized to secure said fitment member to said substrate.

5

5. The system of claim 4 wherein said panels are arranged generally one above another, with said adjacent edges extending generally horizontally, and with said fitment member secured to a lower one of the panels by way of said one set of screws, said fitment member secured to said substrate by said another set of screws, and an upper one of said panels engaging said fitment member via corresponding first and second flanges only.

10

6. The system of claim 1 wherein said web portion has an outer end portion that extends beyond the outer surface of panels engaged therewith.

15

7. The system of claim 1 wherein said web portion has an outer end portion that is flush with the outer surface of panels engaged therewith.

20

8. The system of claim 7 wherein said outer surface of each panel includes a decorative covering and said web portion outer end portion matches said decorative covering.

25

9. The system of claim 7 wherein said outer surface of each panel includes a decorative covering and said web portion outer end portion contrasts with said decorative covering.

30

10. A fitment member for use in a panelling system to interconnect at least two panels together along adjacent edges thereof, said fitment member comprising an elongated central web portion, a pair of first flanges extending laterally from the web portion intermediate the ends thereof and along the length thereof, and a pair of second flanges extending from one end of the web portion, each of said second flanges being sized for mating reception in a corresponding rabbet portion formed in an inner surface of a panel along the edge thereof, one of said second flanges including means

for securing the fitment member to the panel associated therewith and the other of said second flanges including means for securing said fitment member to a substrate to be covered, whereby in use a connecting portion of each panel will be tightly engaged by said first and second flanges on each side of the web portion such that the panels will be spaced apart by the thickness of the web portion.

11. The fitment member of claim 10 wherein each of said first flanges decreases in thickness towards the outer end thereof to facilitate entrance of the first flange into a corresponding kerf of the panel connecting portion.

12. The fitment member of claim 10 wherein each of said securing means comprises a plurality of countersunk apertures extending through the respective second flange for reception of corresponding flat-head screws, with the apertures of one of said second flanges being oriented opposite to the apertures of the other of said second flanges, whereby one set of said screws can be utilized to secure said fitment member to one of said panels and another set of screws can be utilized to secure said fitment member to the substrate.

13. The fitment member of claim 12 wherein, with said panels arranged generally one above another, and with said adjacent edges extending generally horizontally, said fitment member can be secured to a lower one of the panels by way of said one set of screws, said fitment member can be secured to said substrate by said another set of screws, and an upper one of said panels can engage said fitment member via corresponding first and second flanges only.

14. The fitment member of claim 10 wherein said web portion has an outer end portion that in use extends beyond an outer surface of panels engaged therewith.

15. The fitment member of claim 10 wherein said web portion has an outer end portion that in use is flush with an outer surface of panels engaged therewith.

16. The fitment member of claim 15 wherein said web portion outer end portion matches a decorative covering provided on said panels.

17. The fitment member of claim 15 wherein said web portion outer end portion contrasts with a decorative covering provided on said panels.

5 18. A panelling system for covering interior wall surfaces of an elevator cab with a plurality of panels, said system comprising a plurality of panels adapted for fitment together along adjacent edges thereof and a plurality of fitment members adapted for connection to adjacent pairs of panels to interconnect such adjacent panels together;

10 each said panel having a panel body, an outer surface, an inner surface and a plurality of edges, a kerf extending into said panel body between said inner and said outer surfaces from at least one of said panel edges, and a rabbet portion extending into said panel body at said inner surface from said at least one panel edge; and

15 each said fitment member including a central web portion, a pair of first flanges extending laterally from said web portion and adapted for a tight fit in a respective panel kerf, and a pair of second flanges extending from one end of said web portion and adapted for a flush fit in a respective rabbet portion of a panel;

20 one of said second flanges of each fitment member including means for securing that fitment member to the panel associated therewith and the other of said second flanges including means for securing said fitment member to a wall surface to be covered;

25 whereby with the pair of panels engaging said fitment member along the respective adjacent panel edges, said panels will be spaced from each other by the thickness of said fitment member web portion and said panels will be interconnected by way of said first and second flanges engaging the respective kerfs and rabbet portions.

19. The panelling system of claim 18 wherein said fitment members can extend generally vertically, generally horizontally, or at an angle to the vertical within said elevator cab.

30 20. The panelling system of claim 18 including a decorative cap member having a web portion, a first flange extending laterally of said web portion, and a second flange extending from an end of said web portion parallel to said first flange, said cap member being adapted for fitment in the kerf and rabbet portion of an end panel.

21. The system of claim 18 wherein each of said first flanges decreases in thickness towards the outer end thereof to facilitate entrance of the first flange into a corresponding kerf.

5 22. The system of claim 18 wherein each of said securing means comprises a plurality of apertures extending through the respective second flange for reception of fastening means adapted to secure said fitment member to the panel or to the substrate.

10 23. The system of claim 18 wherein each of said securing means comprises a plurality of countersunk apertures extending through the respective second flange for reception of corresponding flat-head screws, with the apertures of one of said second flanges being oriented opposite to the apertures of the other of said second flanges, whereby one set of said screws can be utilized to secure said fitment member to one
15 of said panels and another set of screws can be utilized to secure said fitment member to said substrate.

24. The system of claim 23 wherein said panels are arranged generally one above another, with said adjacent edges extending generally horizontally, and with said
20 fitment member secured to a lower one of the panels by way of said one set of screws, said fitment member secured to said substrate by said another set of screws, and an upper one of said panels engaging said fitment member via corresponding first and second flanges only.

25 25. The system of claim 18 wherein said web portion has an outer end portion that extends beyond the outer surface of panels engaged therewith.

26. The system of claim 18 wherein said web portion has an outer end portion that is flush with the outer surface of panels engaged therewith.

30 27. The system of claim 26 wherein said outer surface of each panel includes a decorative covering and said web portion outer end portion matches said decorative covering.

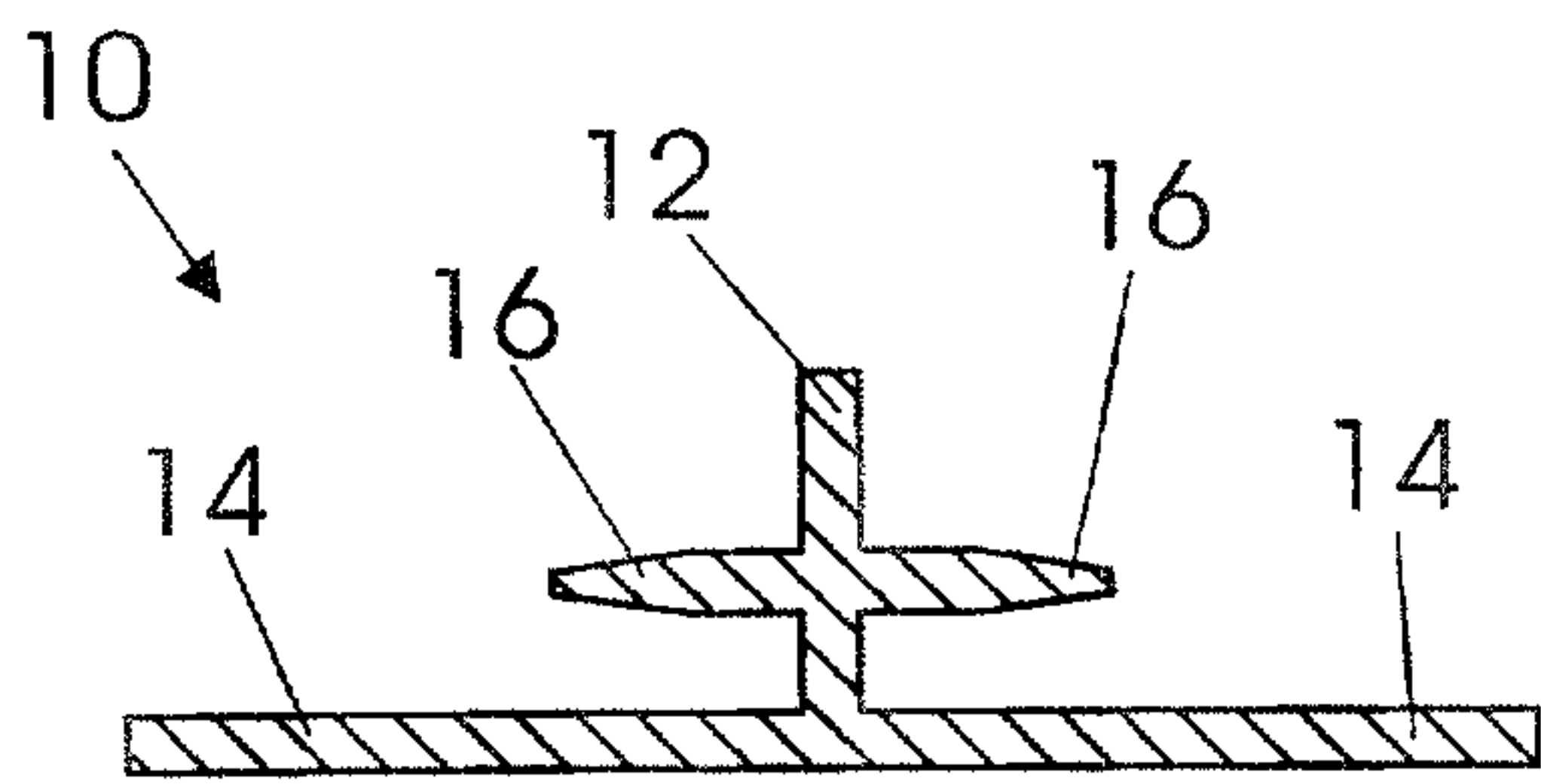

FIG. 1

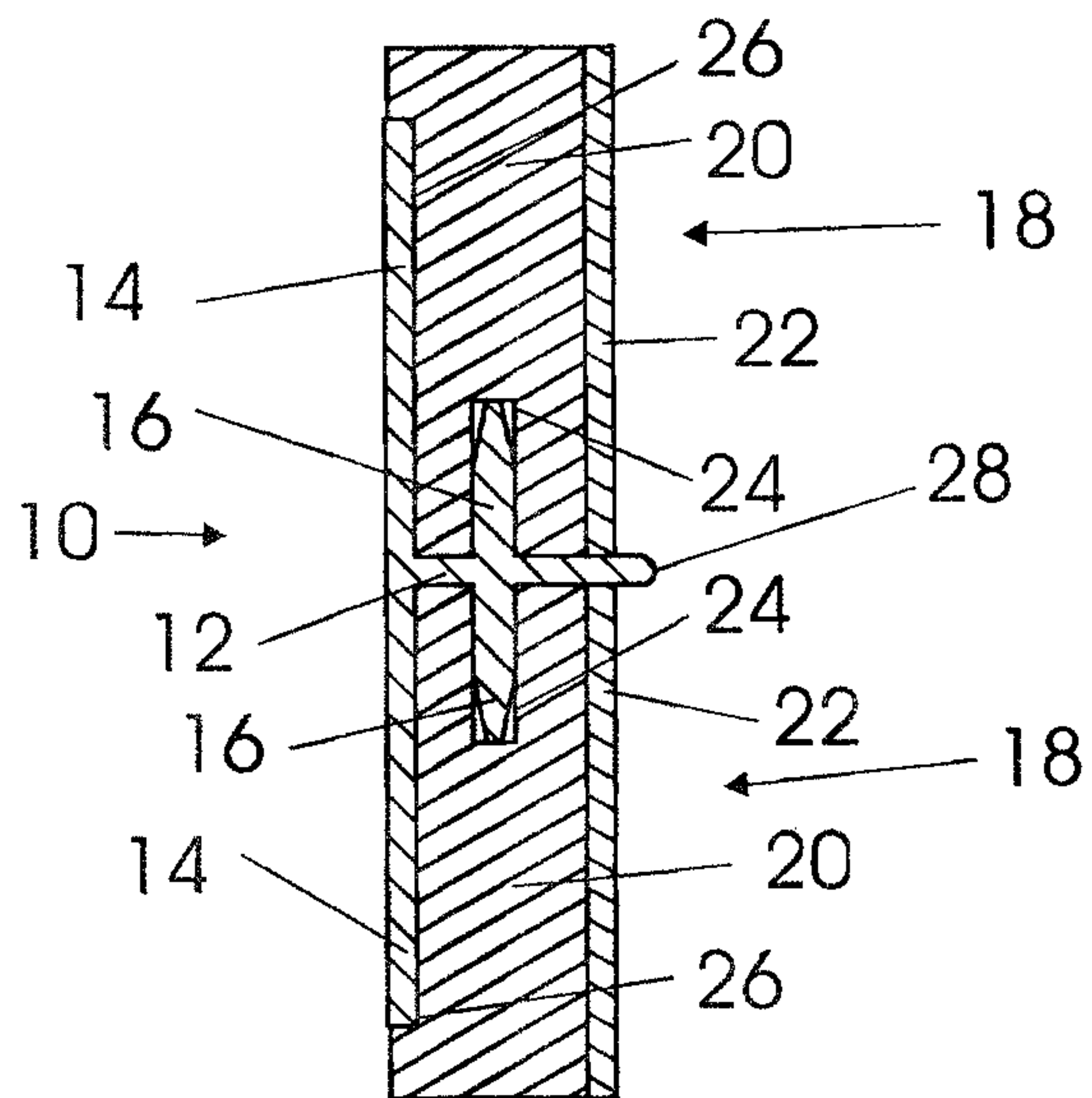

FIG. 2

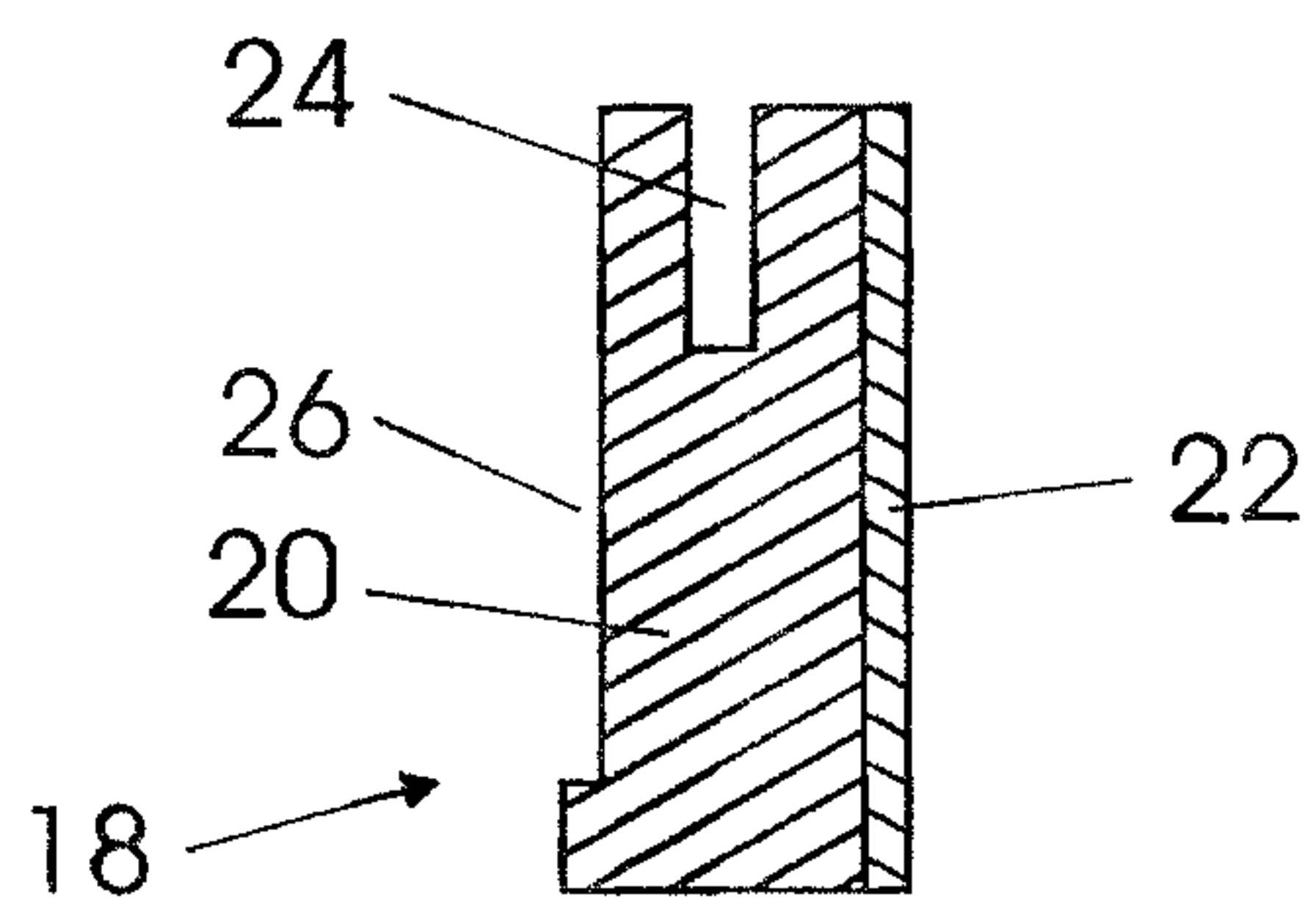

FIG. 3

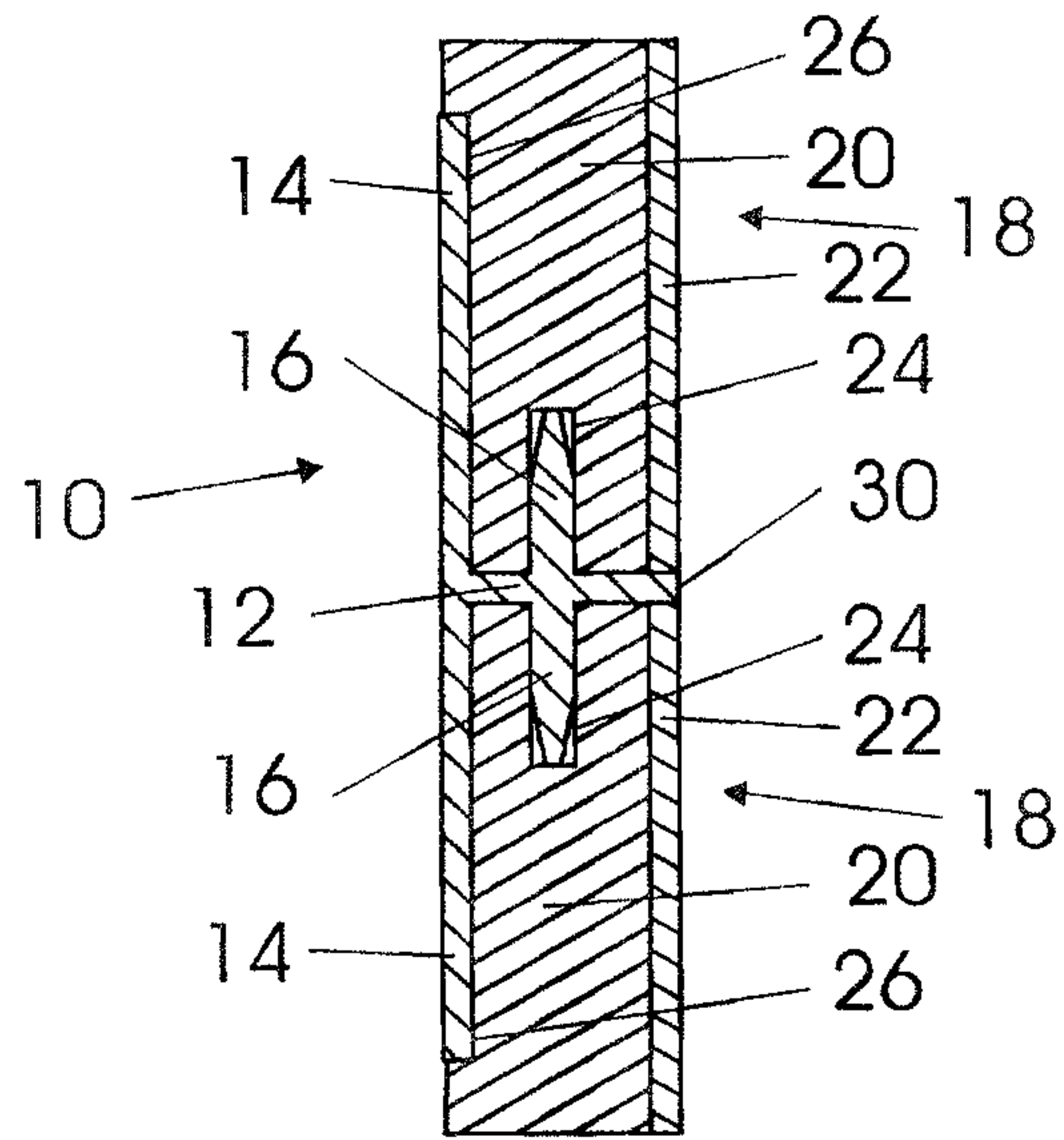

FIG. 4

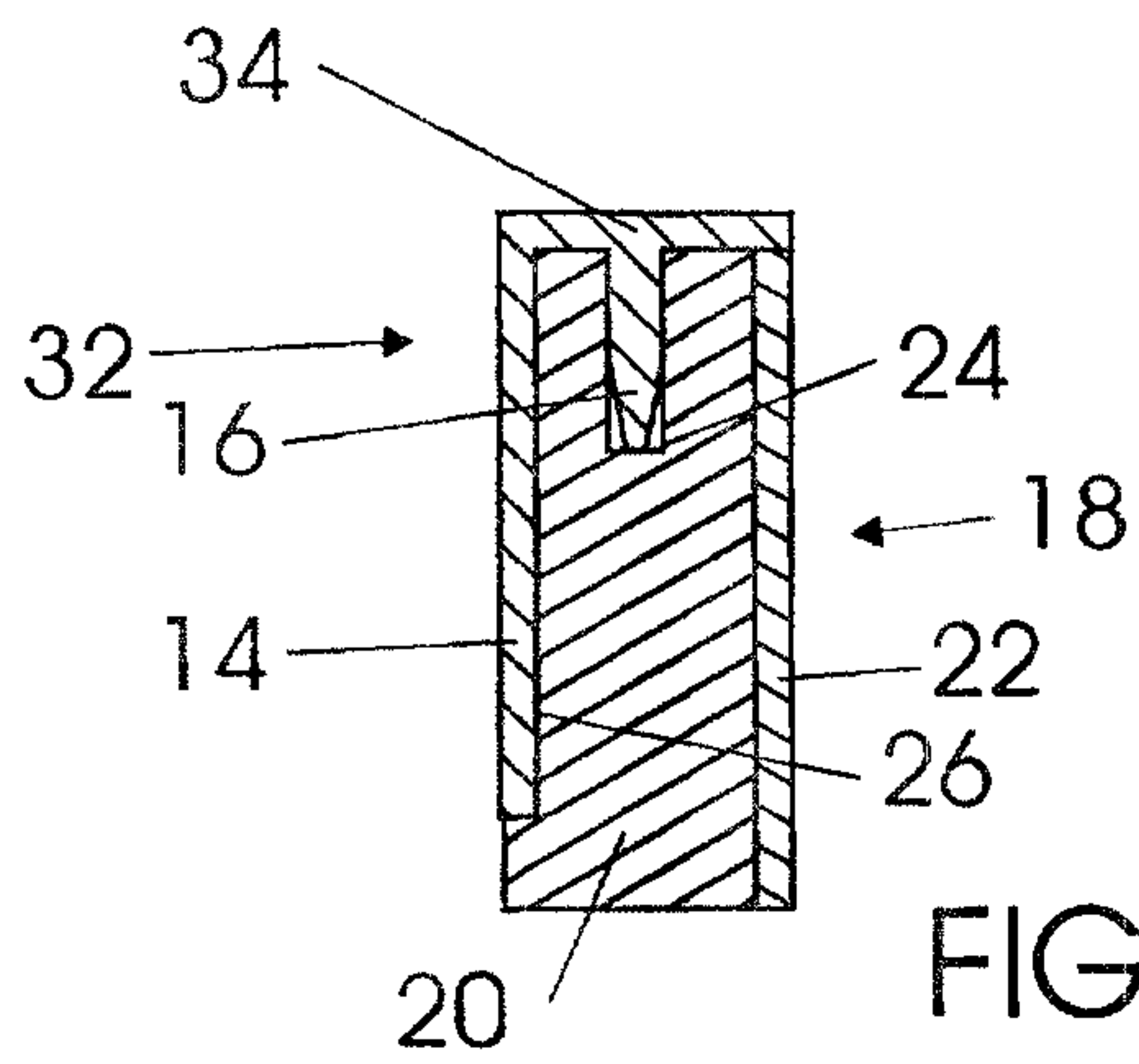

FIG. 5

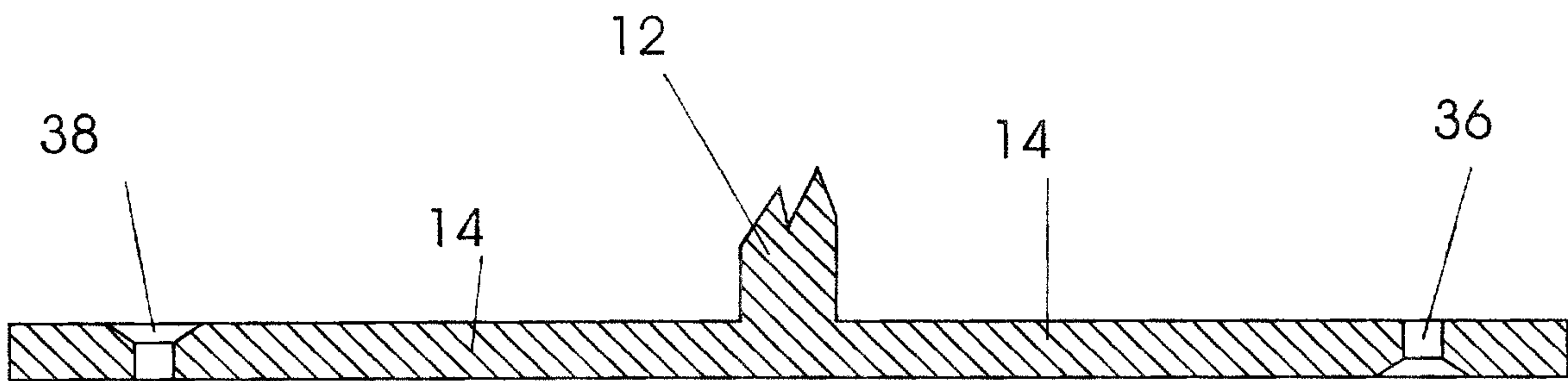

FIG. 6

