

(21) Application No 8029817
(22) Date of filing 16 Sep 1980
(30) Priority data
(31) 7932948
(32) 22 Sep 1979
(33) United Kingdom (GB)
(43) Application published 29 Apr 1981
(51) INT CL³
G01L 1/04 F16B 31/02

(52) Domestic classification
G1W E7A

(56) Documents cited
GB 1426965
GB 1213734
GB 1150062
GB 997556
GB 961621
GB 928379
GB 632601

(58) Field of search
F2H
G1W

(71) Applicants
David Brown Gear
Industries Limited, Park
Gear Works, Huddersfield,
West Yorkshire

(72) Inventors
Richard Brian Whitaker,
John Allon Sellers,
Albert Edward
Wolstencroft

(74) Agent
Kenneth Adrian Norcliffe,
David Brown Tractors
Limited, Meltham Mills,
Meltham, Huddersfield
HD7 3AR, West Yorkshire

(54) Measuring bolt elongation

(57) In the assembly of highly-stressed accurately-dimensioned high-reliability mechanisms, for example large marine gearboxes, it is desirable to control precisely the clamping forces exerted by bolts in the mechanisms. The apparatus

comprises a body 18, 24 which can be mounted at one end of the bolt 10 by a tie-rod 21 passed through an axial hole 11 in the bolt, a spring 27 taking up axial clearance between the body and the bolt by urging them apart, and an indicator 31 fixed to the body and having a probe 33 contacting the adjacent end of the bolt.

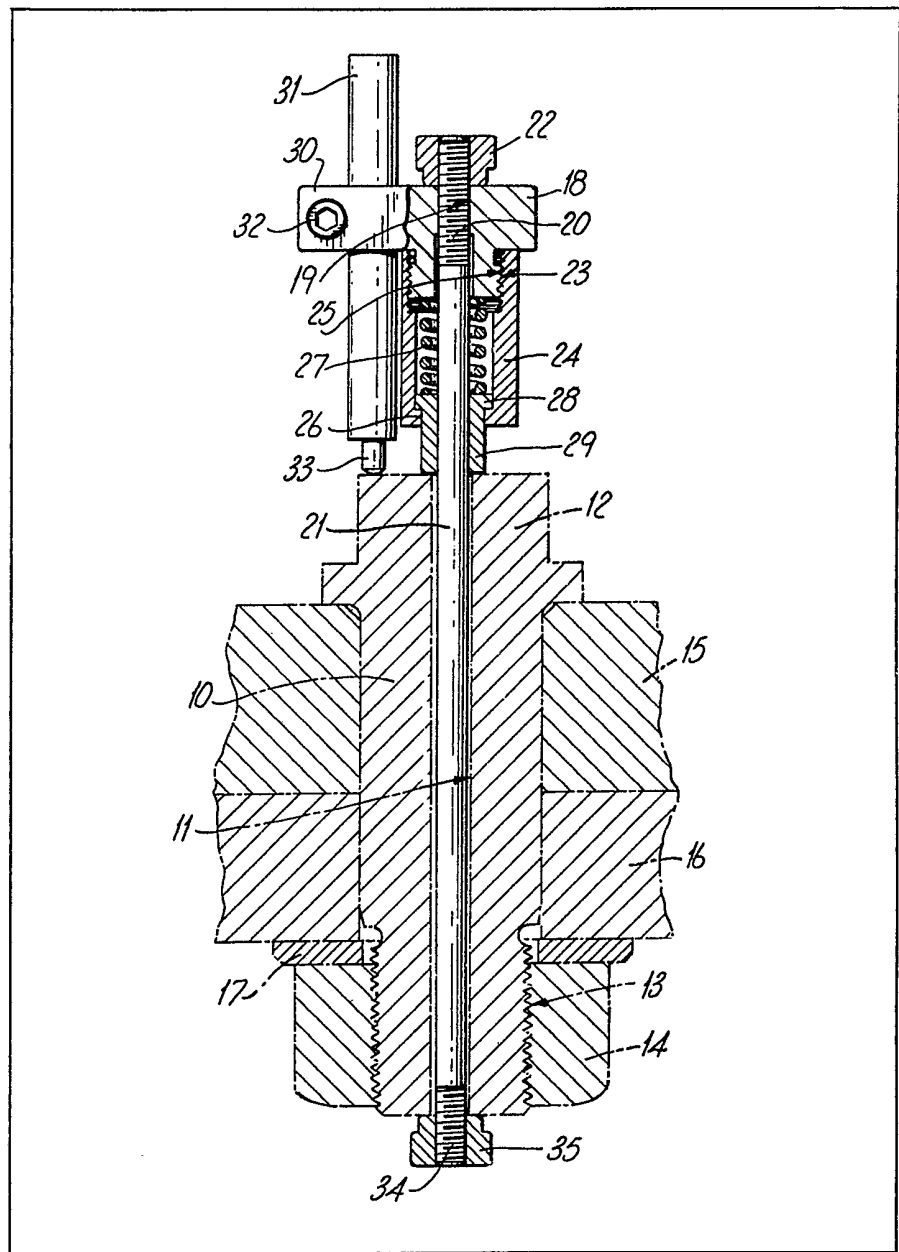

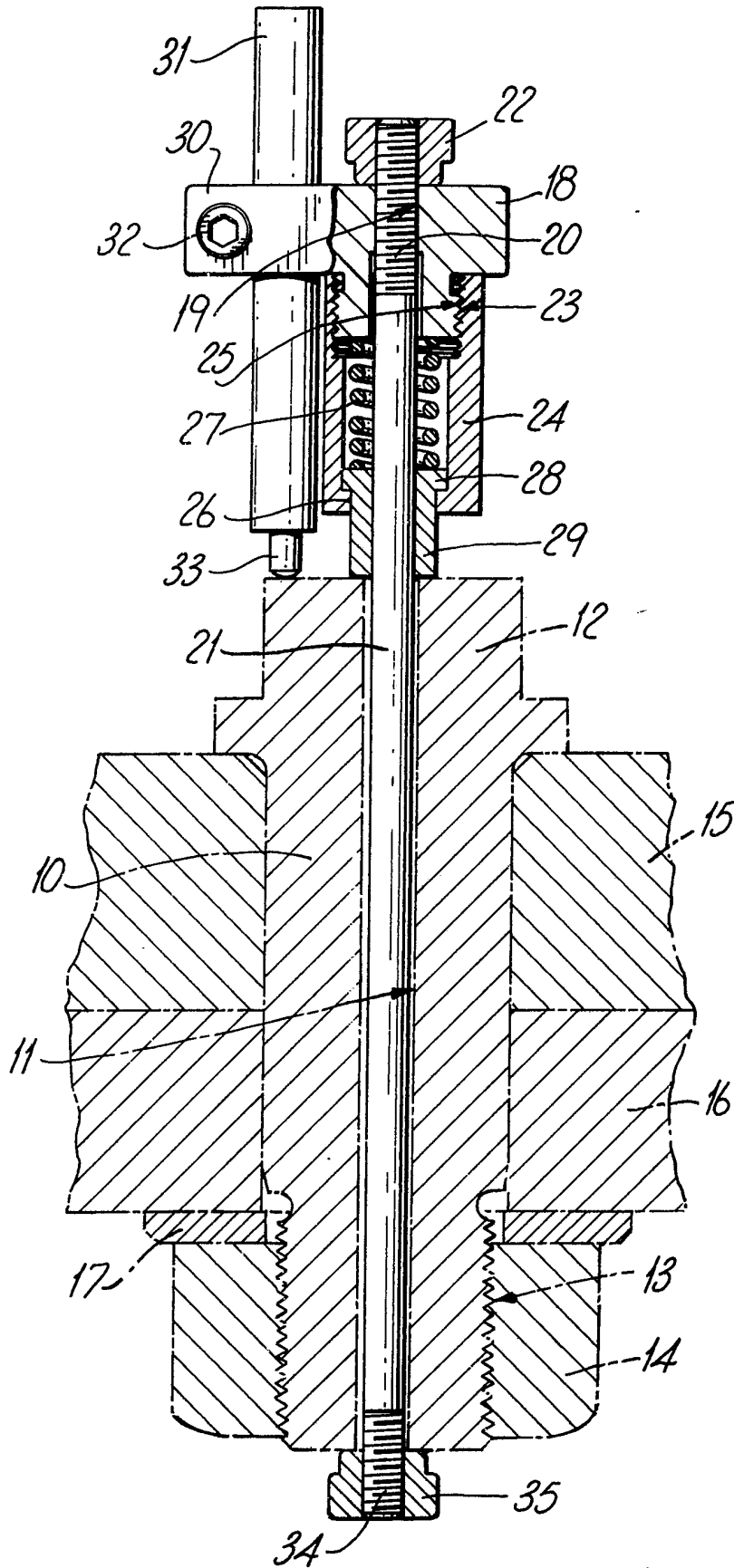

SPECIFICATION

Bolt elongation measuring apparatus

The invention relates to apparatus for measuring the elongation of a bolt due to the clamping of components between the head of the bolt and a nut tightenable on a screw-threaded zone of the bolt, so that the clamping force can be precisely controlled during tightening. To enable the apparatus to be employed, an axial hole must be provided through the bolt.

According to the invention, apparatus for measuring the elongation of a bolt provided with an axial hole, due to the clamping of components between the head of the bolt and a nut tightenable on a screw-threaded zone of the bolt, comprises a body, a rod adapted to pass through the axial hole in the bolt and to be secured to the body, resilient means adapted to be confined between the body and one end face of the bolt, an abutment on that end of the rod remote from the body adapted to contact the other end face of the bolt so as to locate the apparatus without axial clearance upon the unelongated bolt, and an indicator rigidly secured to the body and having a probe adapted to contact said one end face of the bolt.

A preferred embodiment of the invention will now be described, by way of example, with reference to the accompanying drawing which is a mainly sectional side elevation of bolt elongation measuring apparatus mounted in operative position on a bolt arranged to clamp components together with the aid of a nut and a washer, the bolt, nut, washer and components being shown in broken lines.

Referring now to the drawing, apparatus for measuring the elongation of a bolt 10 provided with an axial hole 11, a head 12, and a screw-threaded zone 13 on which a nut 14 is tightenable in order to clamp components 15, 16 between the head 12 and a washer 17 associated with the nut 14 includes a body comprising a first body portion 18 having a tapped hole 19 in which one screw-threaded end zone 20 of a rod 21 is adjustably engaged, a lock-nut 22 being provided on the zone 20 to secure the rod 21 in axially adjusted position. The first body portion 18 also has an externally screw-threaded boss 23 co-axial with its tapped hole 19, on which a second, tubular, body portion 24 having an internally screw-threaded zone 25 is rigidly secured. The second body portion 24 surrounds a zone of the rod 21, has a radially inwardly extending flange 26 at its end remote from the first body portion 18, and confines between its flange 26 and the boss 23 a helical compression spring 27 and a radially outwardly extending flange 28 on one end of a sleeve 29 slideably surrounding the rod 21, the other end of the sleeve 29 projecting from the second body portion 24. The sleeve 29 and the spring 27 together constitute resilient means. The first body portion 18 has a radial projection 30 to which an electronic remote position indicator 31 is rigidly secured by a locking screw 32. The indicator 31 has a probe 33 moveable in a

direction parallel to the rod 21, the end of the probe 33 being disposed, prior to the location of the apparatus upon the bolt 10, slightly on that side remote from the body of the plane perpendicular to the axis of the rod 21 which contains the projecting end of the sleeve 29. The other end zone 34 of the rod 21 is also screw-threaded, and an abutment consisting of a knurled nut 35 is adapted to fit thereon.

In operation, the axial position of the rod 21 relative to the body is adjusted to suit the length of the bolt 10 concerned, the rod 21 is passed through the axial hole 11 in the bolt 10, and the knurled nut 35 is then screwed on to the end zone 34 of the rod 21 until the apparatus is located upon the unelongated bolt 10 without axial clearance but without significantly compressing the spring 27. Normally the sleeve 29 and the probe 33 are arranged to contact the larger end face, that is to say the head 12, of the bolt 10, in which event the knurled nut 35 contacts the opposite end face thereof. This depresses the probe 33 slightly, and therefore the read-out of the indicator 31 must next be zeroed. As the nut 14 on the screw-threaded zone 13 of the bolt 10 is then tightened in order to clamp the components 15, 16 between the head 12 and the nut 14 and washer 17, the bolt 10 elongates and in so doing depresses the sleeve 29 against the action of the spring 27 and contemporaneously depresses the probe 33. Tightening is continued until the read-out of the indicator 31 shows that a precise predetermined elongation of the bolt 10, and thus a precise predetermined clamping force, has been attained. Finally the knurled nut 35 is unscrewed and the apparatus removed from the installed bolt 10.

In a modification, the rod passes slideably through a clearance hole in the first body portion, still has a screw-threaded zone at that end adjacent the body, and has a nut and a lock-nut on said zone. In another modification, the screw-threaded zone at that end of the rod remote from the body, and the knurled nut thereon, are replaced by a head fixed on said end of the rod.

110 CLAIMS

1. Apparatus for measuring the elongation of a bolt provided with an axial hole, due to the clamping of components between the head of the bolt and a nut tightenable on a screw-threaded zone of the bolt, comprising a body, a rod adapted to pass through the axial hole in the bolt and to be secured to the body, resilient means adapted to be confined between the body and one end face of the bolt, an abutment on that end of the rod remote from the body adapted to contact the other end face of the bolt so as to locate the apparatus without axial clearance upon the unelongated bolt, and an indicator rigidly secured to the body and having a probe adapted to contact said one end face of the bolt.

2. Apparatus according to claim 1, wherein the resilient means comprise a spring-loaded sleeve confined in but projecting from the body, slideably

surrounding the rod and adapted to contact said one end face of the bolt.

3. Means according to either of the preceding claims, wherein the rod is axially adjustably
5 secured to the body.

4. Apparatus according to claim 3, wherein the body has a tapped hole in which a screw-threaded end zone of the rod is adjustably engaged.

5. Apparatus according to claim 3, wherein
10 the body has a clearance hole through which a screw-threaded end zone of the rod passes slideably and is adjustably engaged by a nut.

6. Apparatus according to any one of the preceding claims, wherein the abutment on that
15 end of the rod remote from the body comprises a nut which fits adjustably on a screw-threaded

zone at said end of the rod.

7. Apparatus according to any one of claims 1 to 5, wherein the abutment on that end of the rod
20 remote from the body comprises a head fixed thereon.

8. Apparatus according to any one of the preceding claims, wherein the indicator is an electronic remote position indicator.

9. Apparatus for measuring the elongation of a bolt provided with an axial hole, due to the
25 clamping of components between the head of the bolt and a nut tightenable on a screw-threaded zone of the bolt, constructed, arranged and
30 adapted to operate substantially as hereinbefore described with reference to, and as illustrated by, the accompanying drawing.