



(51) International Patent Classification:

B61L 3/12 (2006.01) B61L 25/02 (2006.01)
B61L 3/00 (2006.01) B61L 25/04 (2006.01)
B61L 15/00 (2006.01) B61L 27/00 (2006.01)
B61L 23/08 (2006.01)

(21) International Application Number:

PCT/IB2019/050531

(22) International Filing Date:

22 January 2019 (22.01.2019)

(25) Filing Language:

English

(26) Publication Language:

English

(30) Priority Data:

15/878,157 23 January 2018 (23.01.2018) US
15/992,883 30 May 2018 (30.05.2018) US

(71) Applicant: ARUP VENTURES LIMITED [GB/GB]; 13 Fitzroy Street, London W1T 4BQ (GB).

(72) Inventor: GARMSON, Kenneth; 2 Hardwood Court, Warren, New Jersey 07059 (US).

(81) Designated States (unless otherwise indicated, for every kind of national protection available): AE, AG, AL, AM, AO, AT, AU, AZ, BA, BB, BG, BH, BN, BR, BW, BY, BZ, CA, CH, CL, CN, CO, CR, CU, CZ, DE, DJ, DK, DM, DO, DZ, EC, EE, EG, ES, FI, GB, GD, GE, GH, GM, GT, HN, HR, HU, ID, IL, IN, IR, IS, JO, JP, KE, KG, KH, KN, KP, KR, KW, KZ, LA, LC, LK, LR, LS, LU, LY, MA, MD, ME, MG, MK, MN, MW, MX, MY, MZ, NA, NG, NI, NO, NZ, OM, PA, PE, PG, PH, PL, PT, QA, RO, RS, RU, RW, SA, SC, SD, SE, SG, SK, SL, SM, ST, SV, SY, TH, TJ, TM, TN, TR, TT, TZ, UA, UG, US, UZ, VC, VN, ZA, ZM, ZW.

(84) Designated States (unless otherwise indicated, for every kind of regional protection available): ARIPO (BW, GH,

(54) Title: WIRELESS TRAIN MANAGEMENT SYSTEM

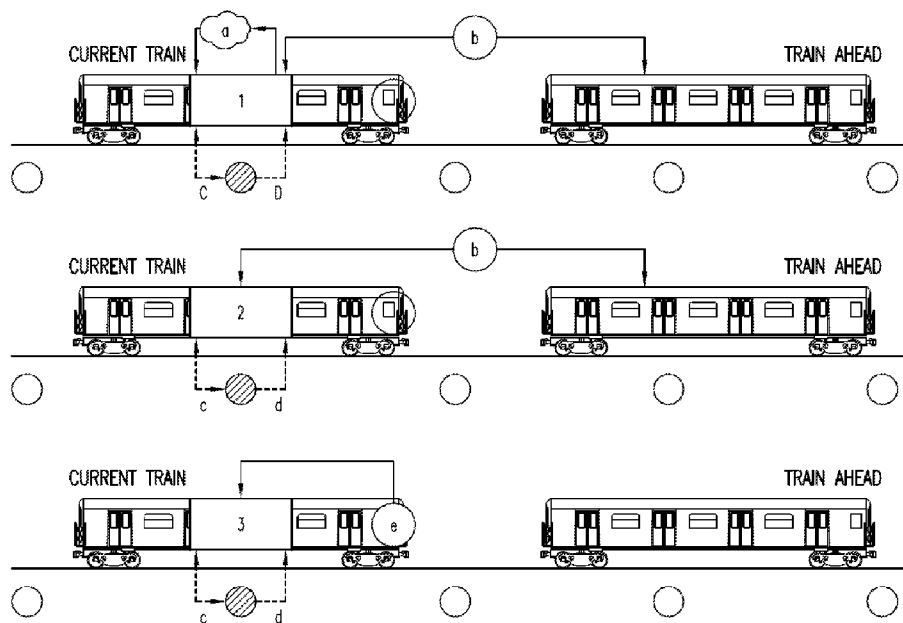

FIG. 1

(57) Abstract: A train system is provided that includes a train set including at least one railway car, at least one first set of two trackside points located along a path of the train set, at least one second set of two trackside points, at least one RFID tag located at each of the trackside points configured to store dynamic and static characteristics of the train set as it passes the at least one first set of two trackside points, at least one RFID tag located at each of the at least one first set of two trackside points and the at least one second set of two trackside points, the at least one RFID tag being configured to store characteristics of the train set as it passes the at least one second set of the at least two track points, and at least one RFID tag reader connected to a network.



GM, KE, LR, LS, MW, MZ, NA, RW, SD, SL, ST, SZ, TZ, UG, ZM, ZW), Eurasian (AM, AZ, BY, KG, KZ, RU, TJ, TM), European (AL, AT, BE, BG, CH, CY, CZ, DE, DK, EE, ES, FI, FR, GB, GR, HR, HU, IE, IS, IT, LT, LU, LV, MC, MK, MT, NL, NO, PL, PT, RO, RS, SE, SI, SK, SM, TR), OAPI (BF, BJ, CF, CG, CI, CM, GA, GN, GQ, GW, KM, ML, MR, NE, SN, TD, TG).

Published:

- *with international search report (Art. 21(3))*
- *before the expiration of the time limit for amending the claims and to be republished in the event of receipt of amendments (Rule 48.2(h))*

WIRELESS TRAIN MANAGEMENT SYSTEM

5

Claim of Priority

This application is a PCT International Application claiming priority to U.S. Patent Application No. 15/992,883, filed May 30, 2018, which is a Continuation of non-provisional U.S. Patent Application No. 15/878,157 filed January 23, 2018, the contents of each of which are
10 incorporated herein by reference in their entirety.

Field of the Embodiments

The field of the present invention and its embodiments relate to a system and method of managing train positions, distances, speeds, and locations within a train system.

15

Background of the Embodiments

Communication Based Train Control (CBTCs) systems have been evolving throughout the years, implementing new versions of technology as they are released and although the CBTC components upgrade overtime, the core system architecture still remains the same as it's fruition in the late 1980's.

20

Advances in data storage and processing now enable far greater digital applications to occur in much smaller footprint and at a fraction of the cost. Along with hardware advances and widespread availability, the adjoining software development has become a much more common skill and is approaching the same commonality as reading and writing skills. With these technological and social advances, an opportunity is presented to redefine the typical CBTC
25 system architecture to elevate train control solutions and make the system relatable to today's world. Train Control processing now has the ability to move from a large centralized control

facility into each train, creating autonomy on the rail, presenting tremendous opportunity for optimization in functionality, operation, maintenance, installation, cost, and so much more.

With many of the industrialized nations and cities around the world having to come to grips with their aging public transportations systems a need and an opportunity arose for a modern approach to overseeing these systems. In recent years, multiple disclosures have attempted to fix various aspects of existing systems. Various systems and methodologies are known in the art. However, their structure and means of operation are substantially different from the present disclosure.

Review of related technology:

10 U.S. Pat. 9,669,850 pertains to a method and system for monitoring rail operations and transport of commodities via rail, a monitoring device including a radio receiver is positioned to monitor a rail line and/or trains of interest. The monitoring device including a radio receiver (or LIDAR) configured to receive radio signals from trains, tracks, or trackside locations in range of the monitoring device. The monitoring device receives radio signals, which are demodulated into
15 a data stream. However, this disclosure requires memory storage of the trains' activities at a central location instead of on the RFID tags.

U.S. Pub. 2017/0043797 pertains to Methods and systems that utilize radio frequency identification (RFID) tags mounted at trackside points of interest (POI) together with an RFID tag reader mounted on an end of train (EOT) car. The RFID tag reader and the RFID tags work
20 together to provide information that can be used in a number of ways including, but not limited to, determining train integrity, determining a geographical location of the EOT car, and determine that the EOT car has cleared the trackside POI along the track. This publication discloses storing memory on the RFID tags but does not disclose having the memory be volatile.

U.S. Pat. 9,711,046 pertains to a control system presenting a configurable virtual representation of at least a portion of a train and associated train assets, including a real-time location, configuration, and operational status of the train and associated train assets traveling along a railway. The control system may include a train position determining system, (such as
5 RFID) and a train configuration determining system.

The train control system disclosed herein establishes a virtual train-to-train communication path, coupled with the on-board processing enabling the trains to operate autonomously and in complete synchronization with all other trains on the line, reducing communication overheads and processing delays inherent in traditional CBTC systems. The open
10 source of software and hardware enable existing train systems to have multiple vendors for the supply chain thereby promoting competitive pricing, and installation flexibility.

Summary of the Embodiments

In general, the present invention and its embodiments describe a system and method of
15 managing train positions, distances, speeds, and locations within a train system. The present system may be implemented onto any existing train system.

According to an embodiment, a train control system is provided. The system includes a train set including at least one railway car, at least one first set of two trackside points located along a path of the train set, at least one second set of two trackside points located along a track
20 switch section, at least one RFID tag located at each of the at least first set of two trackside points configured to store dynamic and static characteristics of the train set as it passes the at least one first set of two trackside points, at least one RFID tag located at each of the at least one first set of two trackside points and the at least one second set of two trackside points, the at least

one RFID tag being configured to store dynamic and static characteristics of the train set as it passes the at least one second set of the at least two track points, and at least one RFID tag reader located on the at least one railway car connected to a network.

It is an object of the present invention to provide the train control system, wherein the at least one RFID tag further comprises a type 1 RFID tag or a type 2 RFID tag.

It is an object of the present invention to provide the train control system, wherein the at least one type 2 RFID tag is connected to a second type 2 RFID tag by an RS485 or serial data transmission cable, wherein the type 2 RFID tag includes an I2C to RS485 converter connected to an RFID chip connected by I2C BUS connection, connected by a parallel connection to a tag antenna.

It is an object of the present invention to provide the train control system, wherein the at least one RFID tag reader comprises an RF transparent enclosure containing inside at least a pair of reader antennas wired to a chip reader, connected to at least one leading railway car or at least one trailing railway car by a wire.

It is an object of the present invention to provide the train control system, wherein the type 1 RFID tag and the RFID tag reader have a separation between approximately 7 inches and 40 inches.

It is an object of the present invention to provide the train control system, wherein the RFID tag reader is located on an underside of a leading railway car or an underside of a trailing railway car.

It is an object of the present invention to provide the train control system, wherein the at least one train type 1 RFID tag comprises multiple type 1 RFID tags spaced apart by less than approximately 30 feet from each other.

It is an object of the present invention to provide the train control system, wherein a network database on a leading railway car is connected to a network database on the trailing railway car by a Bluetooth or a Wi-Fi connection.

5 It is an object of the present invention to provide the train control system, wherein the network of the leading railway car further comprises a radar.

It is an object of the present invention to provide the train control system, wherein a network of a leading railway car or a network of a trailing railway car is connected to a wireless communication network comprising an Ultra-Wide Band, LWIP, LWA, WLAN, ADSL, Cable, or LTE network at locations where the trackside points are at an open track, and a Wi-Fi network
10 at locations wherein the trackside points are at an enclosed track.

It is an object of the present invention to provide the train control system, wherein the system further includes at least one trailing railway car.

According to another aspect of the present invention, a method of controlling a train system is provided. The method includes a first train car of a first train set communicating to a
15 first car of a second train set via a centralized data network route control center, the communication including a track database, a schedule database, and a route database, and the first train car of the first train set communicating to the first car of the second train set via a communication system. The communication system includes at least a first set of two trackside points located along a path of the first train set, at least a second set of two trackside points
20 located along a track switch, at least one first RFID tag located at each of the at least one first set of two trackside points and at least one second set of trackside points, wherein the at least one first RFID tag is configured to store dynamic and static characteristics of the first train set as it passes the at least one first set of two track side points, at least one second RFID tag located at

each of the at least one first set of two trackside points and at least one second set of trackside points, wherein the at least one second RFID tag configured to store dynamic and static characteristics of the train set as it passes the at least one second set of two track points, and at least one RFID tag reader located on the first train set and at least one RFID tag reader located
5 on the second train set.

It is an object of the present invention to provide the method of controlling the train system, wherein the first train car of the first train set communicates, to the first car of the second train set via the communication system, a speed, a location, and a headway of the first train.

It is an object of the present invention to provide the method of controlling the train
10 system, wherein the RFID tag further comprises a type 1 RFID tag or type 2 RFID tag.

It is an object of the present invention to provide the method of controlling the train system, wherein the communication system comprises a backup or a fail-safe system.

It is an object of the present invention to provide the method of controlling the train system, wherein the type 1 RFID tag or the type 2 RFID tag of the backup system stores a speed,
15 a brake status, a train ID, a switch status, a time stamp, and a schedule of a latest train to pass the type 1 RFID tag or the type 2 RFID tag.

It is an object of the present invention to provide the method of controlling the train system, wherein the method further includes rewriting the speed, the brake status, the train ID, the switch status, the time stamp, and the schedule of a latest train to pass the type 1 RFID tag or
20 the type 2 RFID tag, with a next train to pass the type 1 RFID tag or the type 2 RFID tag.

It is an object of the present invention to provide the method of controlling the train system, wherein a speed of a train is adjusted by a backup communication system based on a rail visual distance and time of passing of a preceding train.

It is an object of the present invention to provide the method of controlling the train system, wherein the type 1 RFID tag and the type 2 RFID tag have unique identifiers.

It is an object of the present invention to provide the method of controlling the train system, wherein the rewriting step is completed within between approximately 10 milliseconds and approximately 30 milliseconds.

It is an object of the present invention to provide the method of controlling the train system, wherein the type 1 RFID tag and the type 2 RFID tag include volatile memory.

Brief Description of the Drawings

- 10 **FIG. 1** shows the three modes of operation of system.
- FIG. 2** shows an embodiment of a train set up.
- FIG. 3** shows a possible set up of the system along the tracks.
- FIG. 4** shows a detail of an operational schematic of an embodiment of the system.
- FIG. 5A-5D** shows another detail of an operational schematic of an embodiment of the
- 15 system.
- FIG. 6A-6B** shows the data flow diagram of an embodiment of the system.
- FIG. 7A-7D** shows the data verification of an embodiment of the system.

Description of the Preferred Embodiments

20 The preferred embodiments of the present invention will now be described with reference to the drawings. Identical elements in the various figures are identified with the same reference numerals.

Reference will now be made in detail to each embodiment of the present invention. Such embodiments are provided by way of explanation of the present invention, which is not intended to be limited thereto. In fact, those of ordinary skill in the art may appreciate upon reading the present specification and viewing the present drawings that various modifications and variations
5 can be made thereto.

The present invention, hereinafter referred to as the 'Acorn' system, describes a system that has been designed to allow train sets to operate along a railway autonomously while reducing trackside infrastructure to a minimum. Acorn is based upon the principles and standards noted in IEEE 1474.1: "IEEE Standard for Communications-Based Train Control (CBTC)
10 Performance and Functional Requirements", but, unlike traditional systems using trackside equipment, the equipment located on the train is used to control the movement of trains. At the center of the Acorn design is the placement of Acorn Tags at an interval typically 10-30 feet but preferably at 25 feet along the track. Along straight (or through) track areas, Type 1 Acorn Tags are placed at the typical interval with no hardwire connections. At switch and crossing locations,
15 Type 2 Acorn Tags are deployed at the typical interval with series hardwired connections simulating track circuits. These simulated track circuits can interface with the interlocking controller and communicate with approaching trains, allowing the system to operate seamlessly.

Below, in systems operating at 90 mph, only one Acorn tag and reader interface method is required to achieve a successful read write cycle, simplifying the installation. However, if a
20 deployment needs to support speeds greater than 90 mph, the system can be configured, as is, to leverage a split read write cycle to continue achieving a successful read write cycle.

The Acorn System is an open protocol based system, allowing software applications to be available from multiple vendors and sources and the system being adaptable to various systems

around the world, using multiple operating systems on different platforms. This approach, as with the supply of the Acorn Tags, does not lock the Acorn system into a single supplier of the system. Furthermore, this approach removes common failure modes in both software and hardware of the system.

5 Referring now to FIG. 1, a method for controlling a train system is illustratively depicted, in accordance with an embodiment of the present invention. According to an embodiment, a first train car of a first train set communicates to a first train car of second train set via a centralized data network using radio controlled communication (RCC), wherein the RCC includes a track database, a schedule database, and a route database, with the first train car of the first train set
10 communicating to the first train car of the second train set via a back-up communication system.

According to an embodiment, the system architecture used in the present method enables several layers of communication to transmit and receive the critical data on-board to calculate safe headway. These layers of communication help form the three modes of operation (labelled at 1, 2, and 3 in FIG. 1) to ensure the continuous safe operation of trains. Mode 1 uses all layers
15 of technology to provide the systems minimum headway, leading Mode 1 to be the primary and thus normal mode of operation. According to an embodiment, in Mode 1, normal operation calculates headway with the following redundant inputs: RCC broadcasted Schedule Updates and Train Location confirmations (a); Train to Train broadcasted Train Location confirmations (b); Tag read Train Ahead Time and Speed (c); Tag read Current Train Location confirmation
20 (d); and LIDAR enabled Rail Visual Range sensing clear distance ahead (e).

According to an embodiment, the subsequent mode of operation, Mode 2, is reduced and engages when RCC communication is lost, but allows the system to continue functioning by increasing the minimum headway. Lastly, Mode 3 shows autonomous operation that enables

total train autonomy by relying on tags and on-board equipment information only, imposing the most restrictive headway.

According to an embodiment, the backup communication system includes at least a first set of two trackside points located along a path of the first train set and at least one RFID Type 1 tag located at each of the at least two trackside points configured to store characteristics of the first train set as it passes the first set at least two track side points and at least a second set of two trackside points located along a track switch with at least one RFID Type 2 tag being located at each of the at least two trackside points configured to store characteristics of the train set as it passes the second set of the at least two track points and at least one RFID tag reader being located on the first train set and at least one RFID tag reader located on the second train set.

The RFID type 1 tag or the RFID type 2 tag of the back-up system can store a speed, a brake status, a train ID, a switch status, a time stamp, and a schedule of the latest train to pass the RFID type 1 tag or the RFID type 2 tag. The speed, the brake status, the train ID, the switch status, the time stamp, and the schedule of the latest train to pass the RFID type 1 tag or the RFID type 2 tag, that are recorded on the tags can be rewritten with information with the next train to pass the RFID type 1 tag or the RFID type 2 tag. The read and write step can be typically completed within between approximately 10 milliseconds and approximately 30 milliseconds, but optimally 20 milliseconds is preferred for safe operation of the system.

Each train can carry three principle databases onboard, these being the track, schedule and route databases. The track database contains details of the track network and makes use of the Tag unique ID as the key for the entry record of that location. The temporary Speed field being variable and all others fields (civil speed, the next approaching train, the visual range, the next way point) being fixed unless maintenance has changed a tag. The schedule database allows

the train to determine its location in relationship with other trains in the system. All fields (Train ID, the planned route, Planned time, and confirmed time) can be preloaded be updated throughout the journey. The route database, can contain the information required to navigate the track system. This database contains information pertaining to the expected location of the individual train in relation to time. The location is based on Tag UIDs.

Using the current UID and the Train ID the Planned Time field can be accessed to determine if the train is ahead or behind of the planned schedule. For operation during Modes 2 and 3, the planned location could be determined using the Train Ahead ID and time. The Acorn System databases can be programmed to have in excess of 100,000 records. On the initial startup, a search of all the databases to locate the current Tag UID entry and schedule location may take up to a second to locate the record. Fast indexing will be used thereafter as records will be accessed sequentially, hence incremental increase or decrease.

Train spacing is achieved by establishing the train location from Tags and Inertial navigation system, to an accuracy of at least ± 12.5 ft. This data will be stored by the on-board network map and broadcasted to all trains along the route. The on-board network map also updates with train locations that it receives from other train broadcasts. Allowing the car computers to calculate the distance to train ahead, target speed and braking point to maintain a safe operating distance. The Tag has data fields for Time of last train, speed, running status. With no other received data this enables an on board calculation to determine where the train ahead is if it had applied its emergency brakes. As a train updates, it will broadcast its location to all other trains along the line every 100ft or as determined by the trains operating speed.

To calculate the target speed and available headway for a trainset for use in Modes 2 and 3, the onboard processors can adhere to the following processes:

Headway-the Tag Sequence Array, preloaded from the Track Database, can be used to calculate a distance (in number of tags clear) to train ahead. This value can be known as the Clear Tags value. The tag location of the train ahead can be obtained the following methods: in Mode 1, the Location Database holds the current location of the train ahead. The location can be confirmed via a transmission from the train ahead and a validation has from the Route Control Center. If the location of the Train ahead has been received but not validated by the Route Control Center, then Mode 2 is invoked. Using the preceding train's speed and time when the train was at the tag, the ahead train's location can be predicted assuming a constant speed. This estimated train ahead location is compared to the planned location of that train with the location database and with the reported location from the train. The lower number of the two numbers is used to set the value in the Clear Tags field. If the train has not received any train status updates for more than 500mS then Mode 3 will be invoked. In Mode 3, the train calculates the number of clear tags ahead from the tag data received and uses the scheduled location to amend the tag clear value as required. The Railway Visual Range will be used to modify the maximum speed permissible. From the obtained Tag Clear value, the train length (converted to number of tags) is subtracted. This becomes the planned stop tag for the train. The number of headway tags is then used to address on-board databases to determine the maximum speed that the train can operate at if it is to stop by the stop tag. The maximum speed derived from the on-board databases will then be compared to the Civil Speed, Temporary Speed and choose the lowest value. The data received allows the train to calculate the speed and brake profile of the train ahead.

To determine the speed of the trainset, an Interrupt Request (IRQ) can be used to start a timer sequence that will amount the time between tag reads. The counter will be 64bit using a 100 μ S interval enabling the average speed to be determined using the known tag spacing

between tags. At a speed of 10mph, the counter will reach an integer value of 15,957 between tag readings at the tag spacing, as calculated by the formula below. This counter value could be used to calculate the location of a train between tags, based on the average speed calculated between the previous Tags.

$$5 \quad (\text{velocity}) \left[\frac{ft}{sec} \right] = \frac{25(\text{tag distance})[ft]}{x(\text{integer count}) * 100[\mu S]} * \frac{1,000,000}{1[sec]}$$

$$10 \quad \left[\frac{miles}{hour} \right] = 15.667 \left[\frac{ft}{sec} \right] = \frac{25}{1750} * 10,000$$

For example, using the equations above, with a trainset traveling at 10mph, an accurate location and speed calculation occurs every 1,596mS, thus an accurate location and speed can be
 10 broadcasted to the RCC and other trainsets every 1,596mS. As the speed of the trainset increases, the travel time decreases, allowing for higher broadcast frequency of accurate location and speed values. For example, at an average speed of 25mph, location updates will occur every 682mS, and at 60mph every 284mS. These update periods are all within IEEE standard values prescribed.

15 The Wide Area Network (WAN) Communications may use various technologies and networks to provide various levels of connectivity along different types of track areas. Ideally, communications should exist along the entirety of the track system to support broadcasted trainset locations as mentioned above, although continuous WAN communication is not required to continue operations. The broadcasted trainset locations requires only 1024 bits for data
 20 transmission and 1024 bits for confirmation acknowledgement, and thus minimal communications is required along the entirety of the track system.

In addition to trainset locations, the WAN Communications will need to support schedule updates from the RCC to each train car. Unlike trainset locations, schedule updates require reasonable bandwidth and will need to be supported by high bandwidth networks. Reasonable locations where high bandwidth communications should exist are stations and switch locations, also known as waypoints.

Within the databases, each record is less than 256 bits and, for a single route, is based on:

- 12-hour maximum schedule
- Inclusion of both Local and Express lines
- 120-mile total route length
- 64 trains operation

Then the number of records to be updated is approximately 250kB. Allowing for 16CRC, data verification, and other communication overhead, updating a record of a single train would be 6Mb, and for a complete schedule update 400Mb (50MB). It is noted that various embodiments of the present invention, such as communication and data updating (FIGs. 6A-6B) and data verification (FIGs. 7A-7D) can be presently found in one or more of the present figures (FIGs. 1-7D).

The Acorn System software complexity is significantly less than a typical CBTC system as the need for complex coding has been reduced to simple linear calculations as described in the headway, speed, and location database descriptions above. The individual class structures are defined so that software development of an individual class can be undertaken by different vendors as header file allowing the class to verify independently and not a single source supplier. SIL verification of the code within the header file, if required will be simpler to establish compliance with CENELEC EN 50159 standard, FRA requirements and IEEE standards.

This reduction in coding enables verification to a SIL rating much quicker, as the lines of code are less and multiple vendors can be engaged to provide the code.

At the switch locations, an Acorn Type 2 Tag can be installed for a typical distance of 4,000 feet leading into the actual switch. The Type 2 Tag will allow the interlocking/ARS to
5 communicate with the onboard systems providing status of switch position and target speed for that location. If a dynamic communication between the existing equipment and the Acorn tags is not possible, the interface will provide track circuit emulation using existing trackside signals or in cab signals.

Referring now to FIG. 2, a train control system is illustratively depicted in accordance
10 with an embodiment of the present invention, wherein the system includes a train set having at least one leading car and at least one trailing car, and at least one RFID tag reader located on the at least one leading car and the at least one trailing car connected to a network. According to an embodiment, the RFID tag reader, located on the train (as shown in FIG. 2), can include an RF transparent enclosure containing inside at least a pair of reader antennas wired to a chip reader,
15 connected to the at least one leading car or the at least one trailing car by a wire. According to an embodiment, the network database on the leading car can be connected to the network database on the trailing car by a communication backbone tying together diverse networks, such as Bluetooth and Wi-Fi connections and the network of the leading car and/or the rear car can including a radar.

20 According to an embodiment, the network of the leading car or the trailing car further can be connected to a wireless communication network using an LTE network at locations where the trackside points are at an open track, and a Wi-Fi network at locations where the trackside points are at an enclosed track (as shown in FIG. 4). Alternatively the communication network could

use Ultra-Wide Band (UWB) LWIP, LWA, WLAN, ADSL or Cable networks for communications.

FIG. 3 shows at least a first set of two trackside points located along a path of the train set to which at least one RFID Type 1 tag (Acorn tag) can be connected and configured to store characteristics of the train set as it passes the first set of at least two track side points. FIG. 3 further shows a second set of two trackside points located along a track switch and at least one RFID Type 2 tag (Acorn tag type 2) located at each of the at least two trackside points configured to store characteristics of the train set as it passes the second set of the at least two track points. According to an embodiment, the RFID type 2 tag can be connected to a second RFID type 2 tag by an RS485 cable. The RFID type 2 tag can include an I2C to RS485 converter connected to an RFID chip connected by I2C BUS connection, connected by a parallel connection to a tag antenna. According to an embodiment, the RFID type 1 tag and the RFID tag reader have a separation between approximately 7 inches and 40 inches, with the RFID tag reader can be located on an underside of the leading car and the underside of the trailing car. According to an embodiment, the RFID type 1 tags are spaced apart between approximately 20 to approximately 30 feet from each other, but optimally 25 feet, as seen in FIG. 3.

Referring now to FIG. 4, a detail of an operational schematic is illustratively depicted, in accordance with an embodiment of the present invention.

The interface at the route control center can translate the current train schedule held by the existing system into an Acorn database format adding the additional granularity of target times at each location. As the trains report their locations, the interface will emulate its positional reporting as currently used by the RCC. The second interface to the existing system is the automatic route setting system. If a route has been changed from that planned, the new routes are

converted to an Acorn compatible format and transmitted to the Acorn operating trainsets. These interfaces allow operation with existing and enabling mixed traffic operation, which can also be shown in FIGs. 5A-5D.

As shown in FIG. 4, all train cars within the system will include the Acorn Tag Reader mounted to the underside, Wi-Fi and Bluetooth links between cars, Acorn processing equipment inside or outside the cars, WAN antennas on the top of the cars, radar collision detector on the front of driver cars, and a driver display in driver areas.

The key benefit of the Acorn System is that its introduction into service is by an overlay principle and trackside installation being reduce to a minimum avoiding disruption to the users of the systems while minimizing time and cost. To avoid Cyber hacks of the Tags or communications paths encryption is applied to all transmissions and stored Tag data.

According to an embodiment, introduction of service of the Acorn System will occur seamless as the changeover can be practically overnight.

Comparing the industry standard CBTC solutions, the present invention is the only system to utilize RFIDs with the read and write functions for capturing information from the train ahead. No other CBTC system has the “bread crumb” trail, which is a standalone system that the Acorn can use to operate the trains when all other systems for wireless communications fail. The read/write tags create a virtual block signaling system with the blocks equal to the tag spacing.

Further, embodiments of the present invention include a train control system including at train set comprising at least one leading car and at least one trailing car, at least a first set of two trackside points located along a path of the train set to which at least one RFID Type 1 tag (Acorn tag) can be connected and configured to store characteristics of the train set as it passes

the first set at least two track side points. It is another object of the embodiment of the present invention to have at least a second set of two trackside points located along at a track switch and at least one RFID Type 2 tag (Acorn tag 2) located at each of the at least two trackside points configured to store characteristics of the train set as it passes the second set of the at least two track points and at least one RFID tag reader located on the at least one leading car and at least one trailing car connected to a network.

It is yet another object of the embodiment of the present invention to have a method of controlling a train system comprising by having a first train car of a first train set communicate to a first car of second train set via centralized data network radio controlled communication (RCCs), the communication containing a track database, a schedule database, and a route database. The having the first train car of the first train set communicating to the first car of the second train set via a back-up communication system, the backup communication system (referred to as mode 1 above) including at least a first set of two trackside points located along a path of the first train set; at least one RFID Type 1 tag located at each of the at least two trackside points configured to store characteristics of the first train set as it passes the first set at least two track side points and at least a second set of two trackside points located along at a track switch at least one RFID Type 2 tag located at each of the at least two trackside points configured to store characteristics of the train set as it passes the second set of the at least two track points; and at least one RFID tag reader located on the first train set and at least one RFID tag reader located on the second train set.

Although this invention has been described with a certain degree of particularity, it is to be understood that the present disclosure has been made only by way of illustration and that

numerous changes in the details of construction and arrangement of parts may be resorted to without departing from the spirit and the scope of the invention.

Claims

What is claimed is:

5

1. A train control system comprising:

a train set including at least one railway car;

at least one first set of two trackside points located along a path of the train set;

at least one second set of two trackside points located along a track switch section;

10

at least one RFID tag located at each of the at least first set of two trackside points

configured to store dynamic and static characteristics of the train set as it passes the at least one first set of two trackside points;

at least one RFID tag located at each of the at least one first set of two trackside

15

points and the at least one second set of two trackside points, the at least one RFID tag being configured to store dynamic and static characteristics of the train set as it

passes the at least one second set of the at least two track points; and

at least one RFID tag reader located on the at least one railway car connected to a network.

20

2. The train control system of claim 1, wherein the at least one RFID tag further comprises a type 1 RFID tag or a type 2 RFID tag.

3. The train control system of claim 2, wherein the at least one type 2 RFID tag is connected to a second type 2 RFID tag by an RS485 or serial data transmission cable, wherein the type 2 RFID tag includes an I2C to RS485 converter connected to an RFID chip connected by I2C BUS connection, connected by a parallel connection to a tag antenna.

25

4. The train control system of claim 1, wherein the at least one RFID tag reader comprises an RF transparent enclosure containing inside at least a pair of reader antennas wired to a chip reader, connected to at least one leading railway car or at least one trailing railway car by a wire.
- 5 5. The train control system of claim 2, wherein the type 1 RFID tag and the RFID tag reader have a separation between approximately 7 inches and 40 inches.
6. The train control system of claim 1, wherein the RFID tag reader is located on an underside of a leading railway car or an underside of a trailing railway car.
7. The train control system of claim 2, wherein the at least one train type 1 RFID tag
10 comprises multiple type 1 RFID tags spaced apart by less than approximately 30 feet from each other.
8. The train control system of claim 1, wherein a network database on a leading railway car is connected to a network database on the trailing railway car by a Bluetooth or a Wi-Fi connection.
- 15 9. The train control system of claim 1, wherein the network of the leading railway car further comprises a radar.
10. The train control system of claim 1, wherein a network of a leading railway car or a network of a trailing railway car is connected to a wireless communication network comprising an Ultra-Wide Band, LWIP, LWA, WLAN, ADSL, Cable, or LTE
20 network at locations where the trackside points are at an open track, and a Wi-Fi network at locations wherein the trackside points are at an enclosed track.
11. The system of claim 1, further comprising at least one trailing railway car.
12. A method of controlling a train system comprising the steps of:

a first train car of a first train set communicating to a first car of a second train set via a centralized data network route control center, the communication including a track database, a schedule database, and a route database; and

the first train car of the first train set communicating to the first car of the second train set via a communication system, the communication system including:

at least a first set of two trackside points located along a path of the first train set;

at least a second set of two trackside points located along a track switch;

at least one first RFID tag located at each of the at least one first set of two trackside points and at least one second set of trackside points, wherein the at least one first RFID tag is configured to store dynamic and static characteristics of the first train set as it passes the at least one first set of two track side points;

at least one second RFID tag located at each of the at least one first set of two trackside points and at least one second set of trackside points, wherein the at least one second RFID tag configured to store dynamic and static characteristics of the train set as it passes the at least one second set of two track points; and

at least one RFID tag reader located on the first train set and at least one RFID tag reader located on the second train set.

13. The method of claim 12, wherein the first train car of the first train set communicates, to the first car of the second train set via the communication system, a speed, a location, and a headway of the first train.

14. The method of claim 12, wherein the RFID tag further comprises a type 1 RFID tag or type 2 RFID tag.

15. The method of claim 12, wherein the communication system comprises a backup or a fail-safe system.
16. The method of claim 14, wherein the type 1 RFID tag or the type 2 RFID tag of the backup system stores a speed, a brake status, a train ID, a switch status, a time stamp,
5 and a schedule of a latest train to pass the type 1 RFID tag or the type 2 RFID tag.
17. The method of claim 14, further comprising:
rewriting the speed, the brake status, the train ID, the switch status, the time stamp, and
the schedule of a latest train to pass the type 1 RFID tag or the type 2 RFID tag, with a next train
to pass the type 1 RFID tag or the type 2 RFID tag.
- 10 18. The method of claim 12, wherein a speed of a train is adjusted by a backup communication system based on a rail visual distance and time of passing of a preceding train.
19. The method of claim 12, wherein the type 1 RFID tag and the type 2 RFID tag have unique identifiers.
- 15 20. The method of claim 17, wherein the rewriting step is completed within between approximately 10 milliseconds and approximately 30 milliseconds.
21. The method of claim 12, wherein the type 1 RFID tag and the type 2 RFID tag include volatile memory.

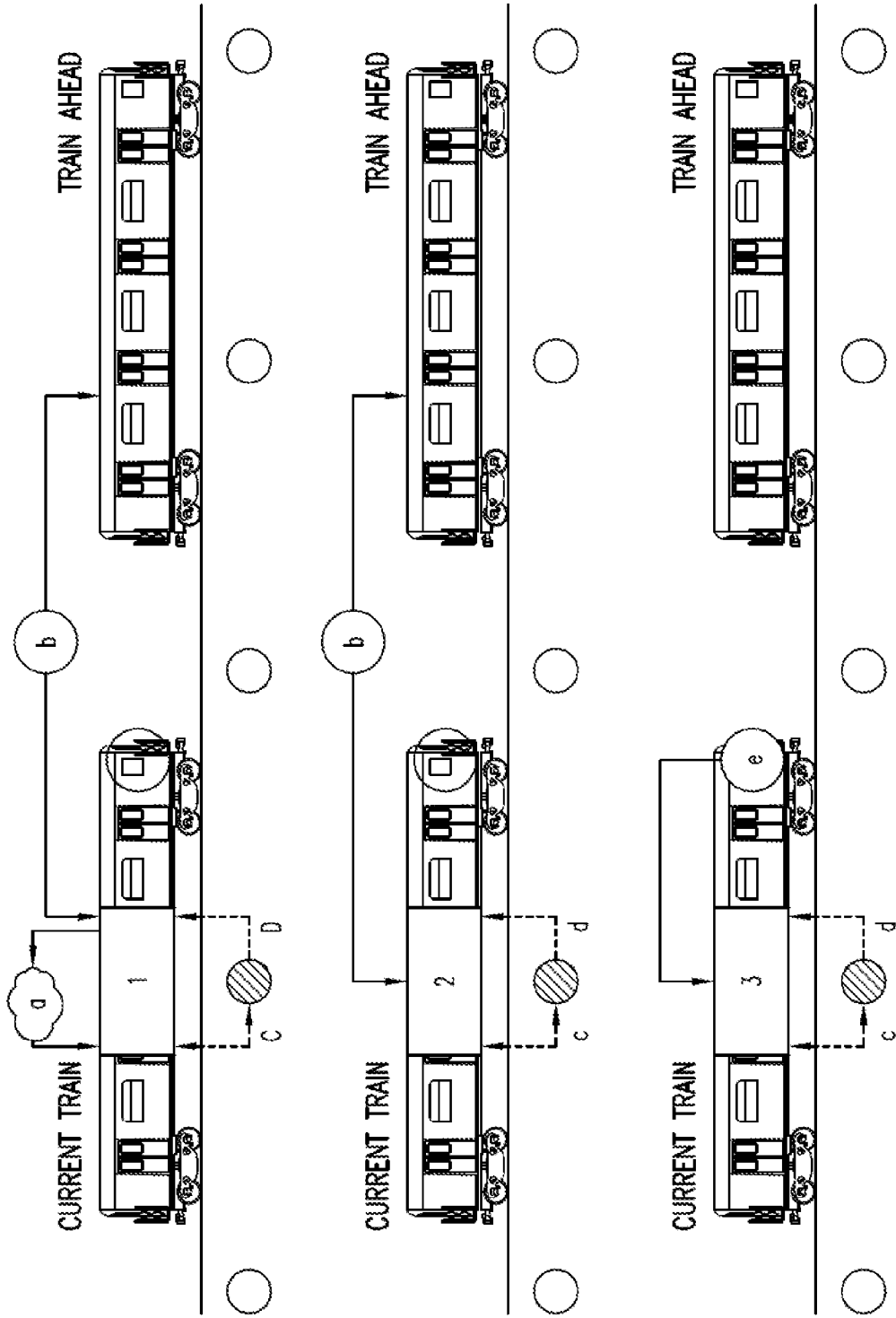

FIG.1

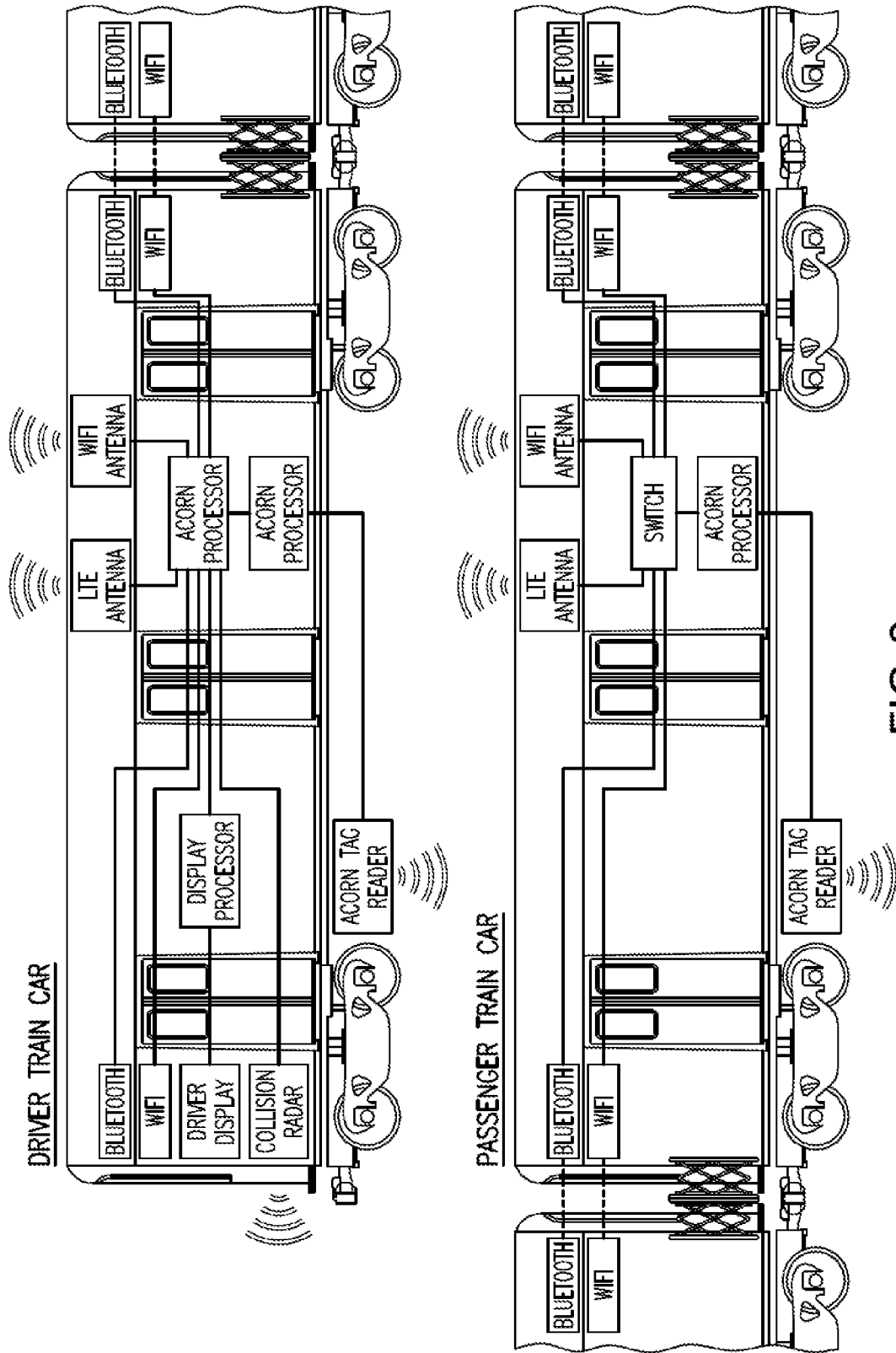

FIG.2

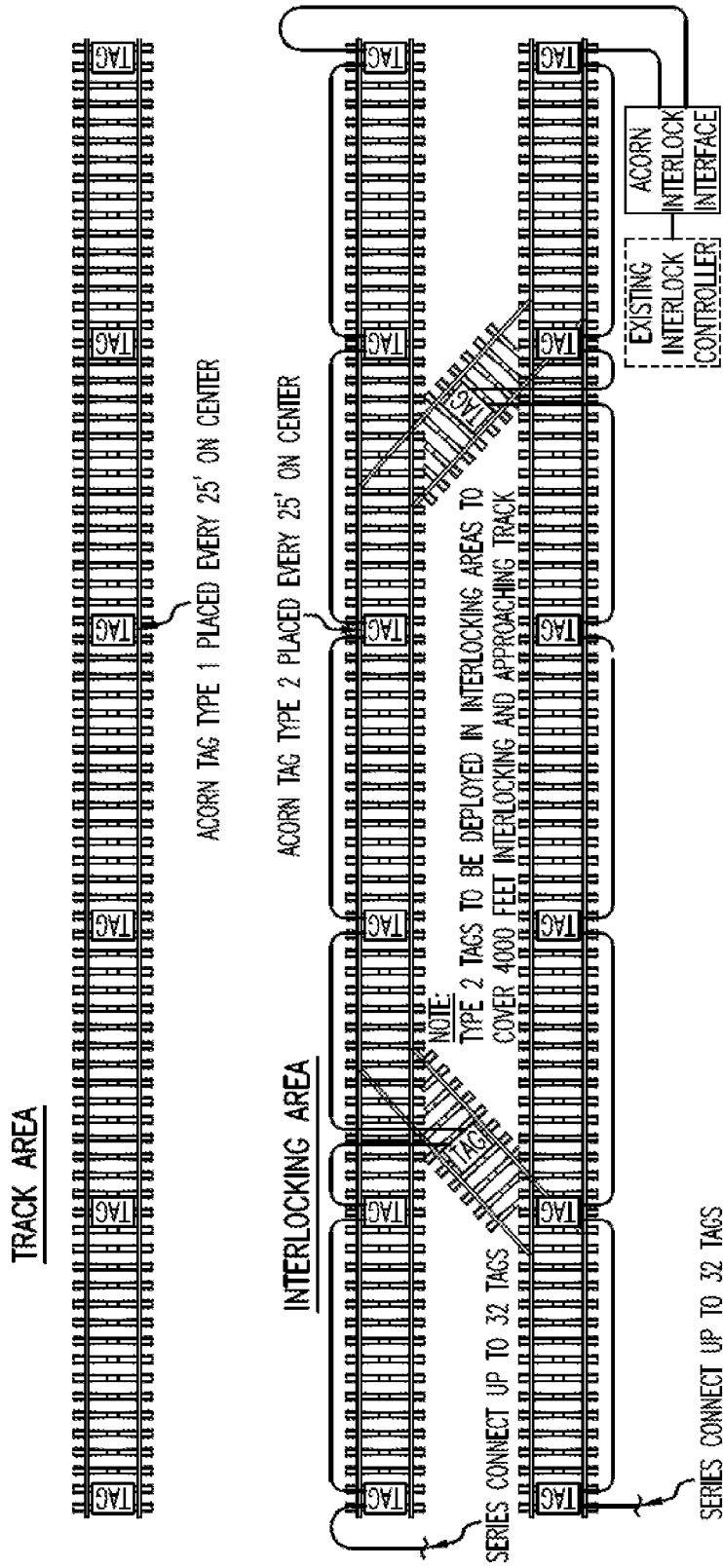

FIG.3

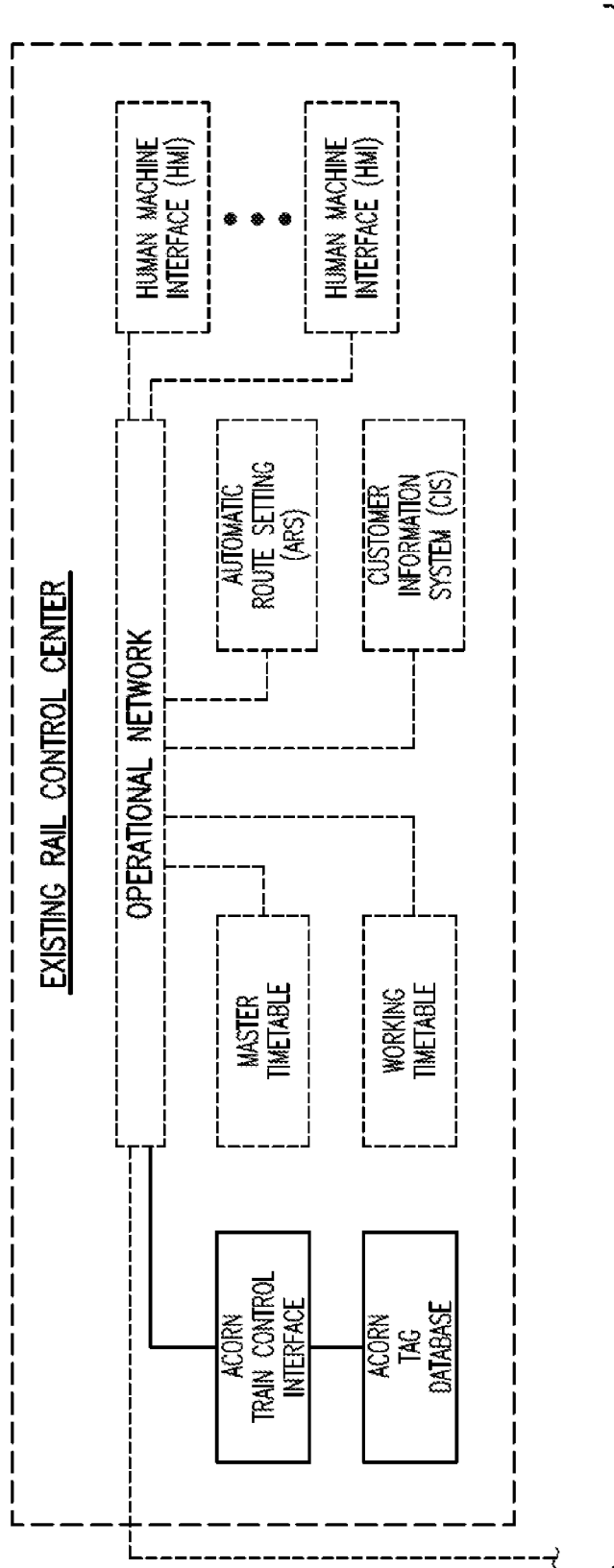
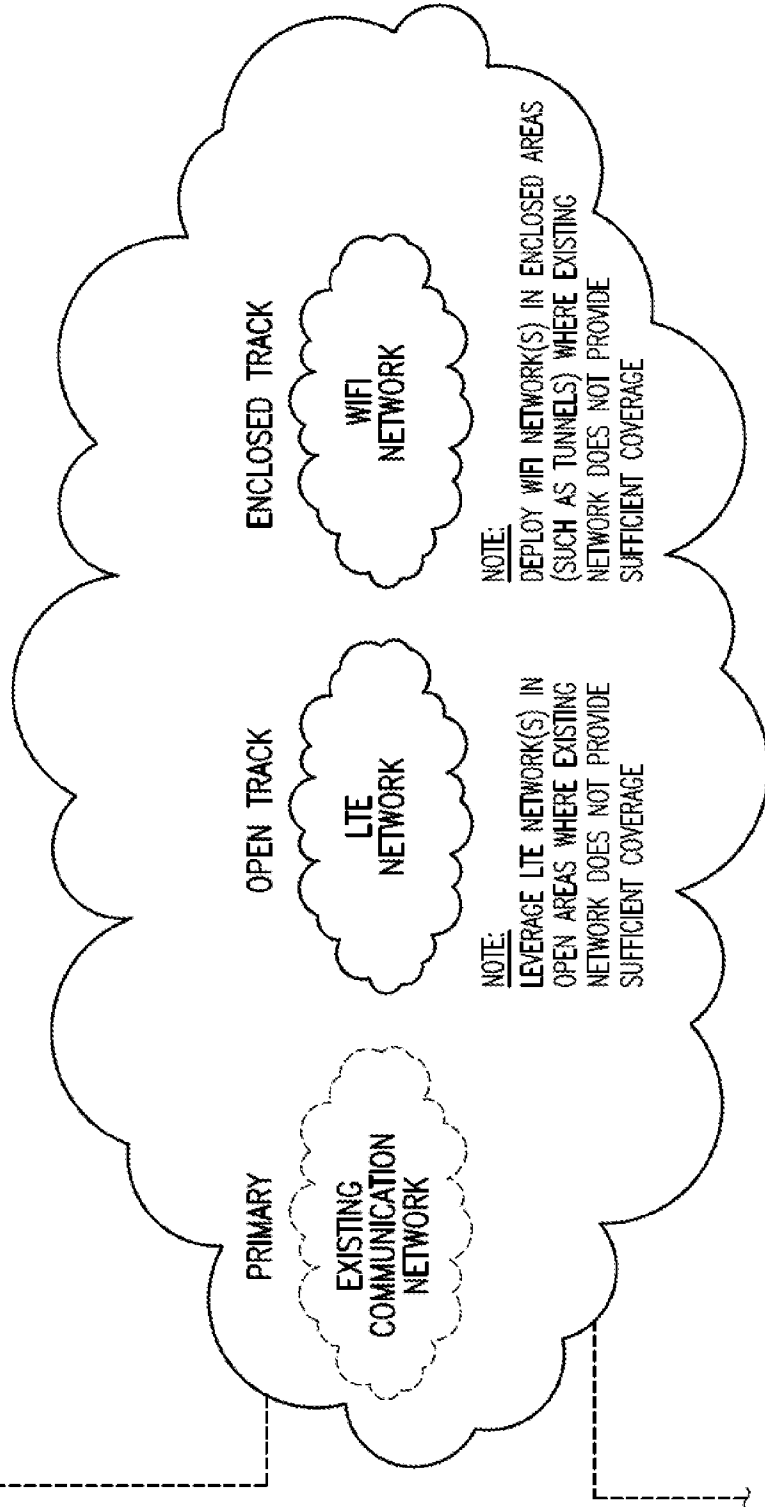

FIG.5A

From FIG.5A

WIRELESS COMMUNICATION NETWORK



Cont. on FIG.5C

FIG.5B

From FIG.5B

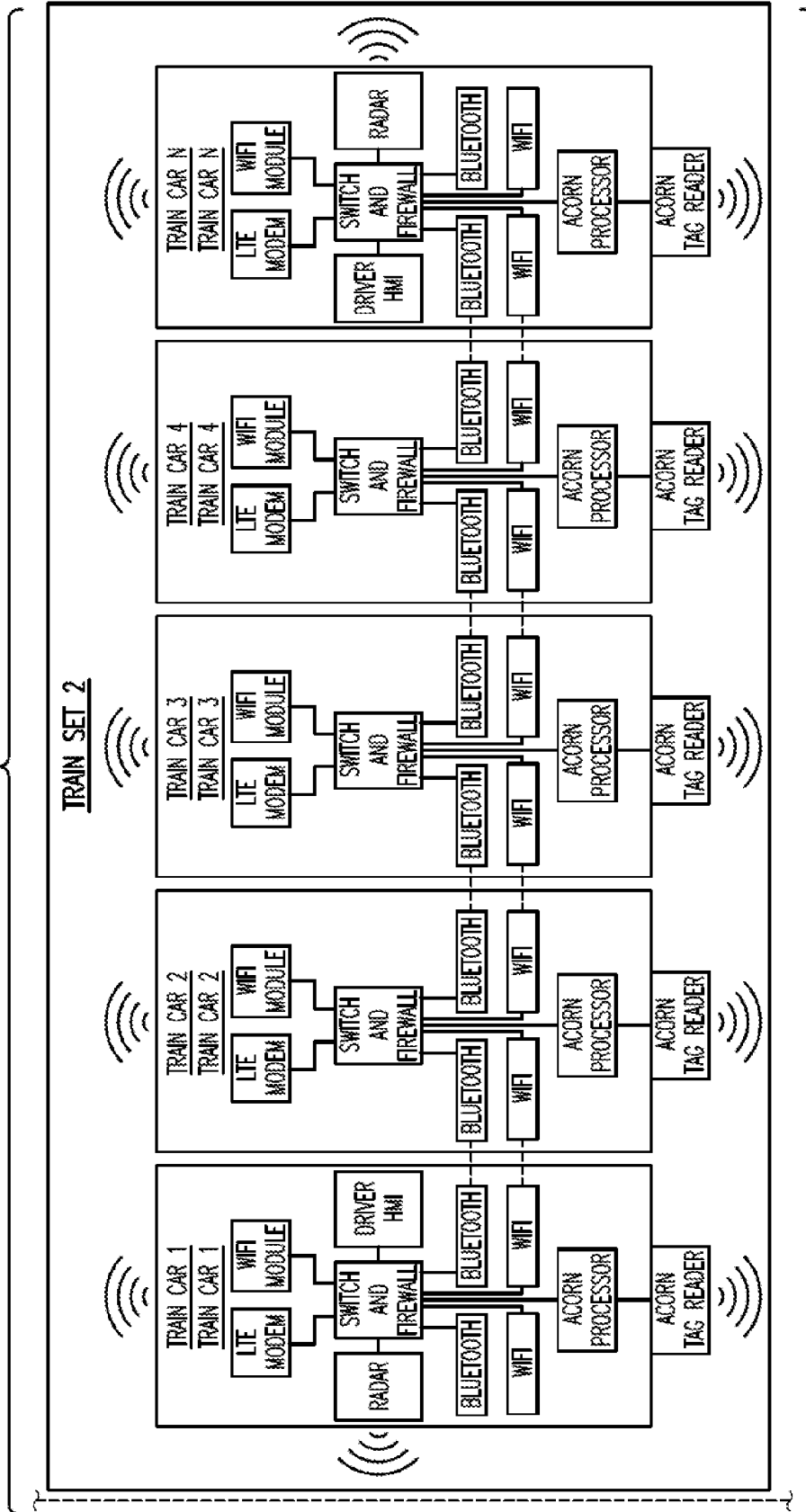

Cont. on FIG.5D

FIG.5C

From FIG.5C

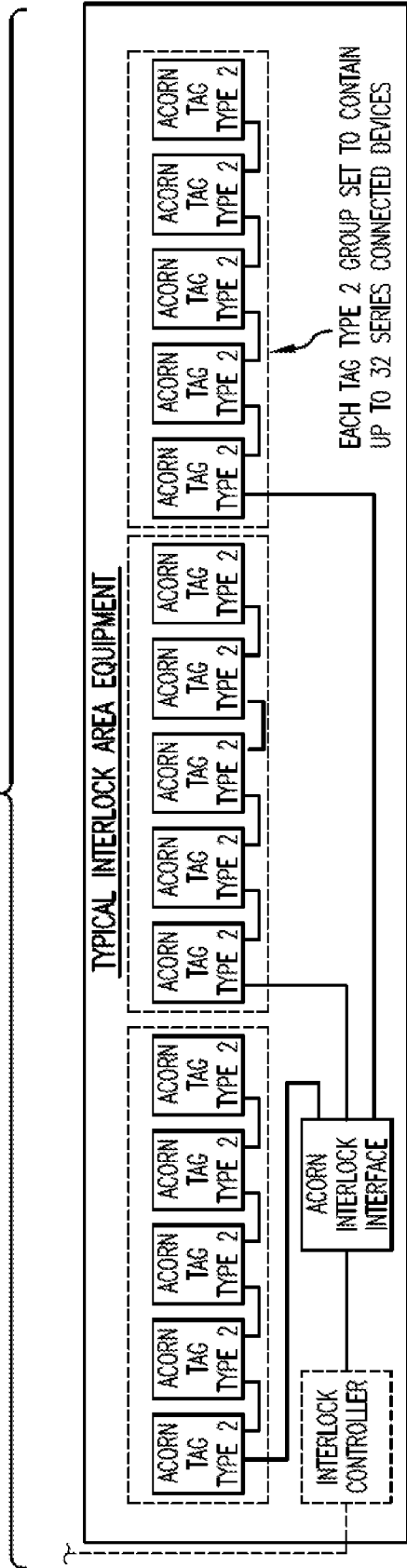

FIG.5D

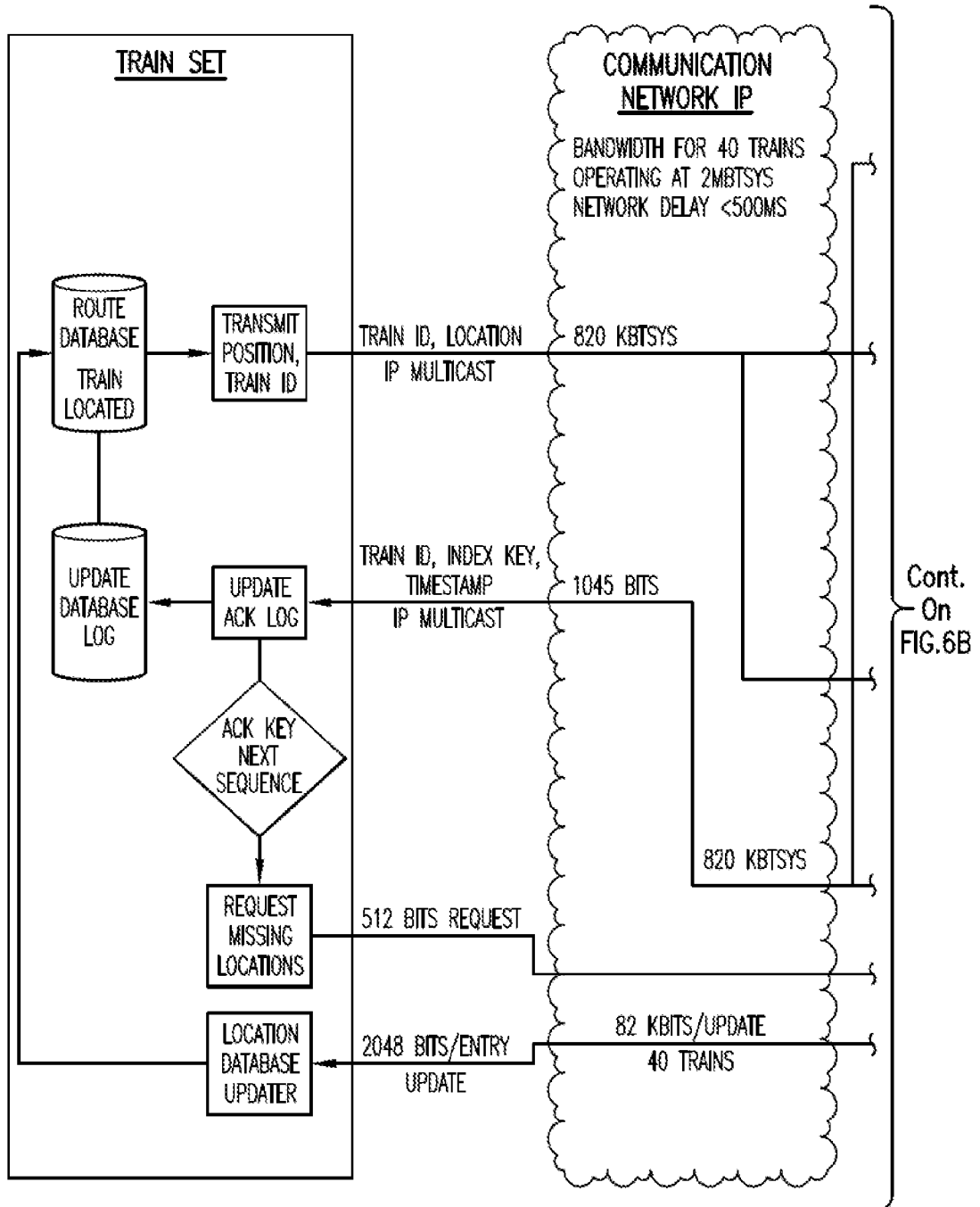

FIG.6A

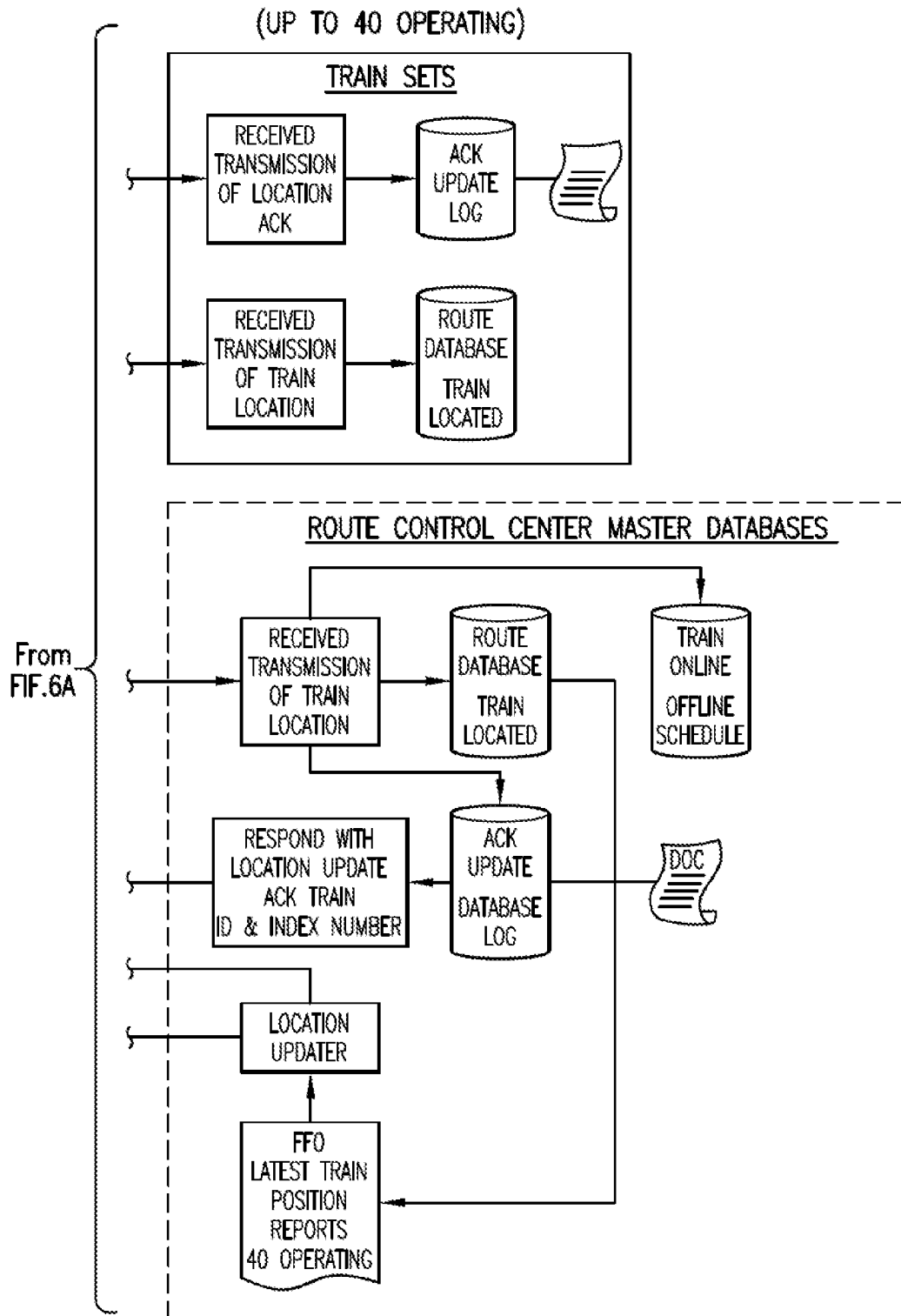

FIG.6B

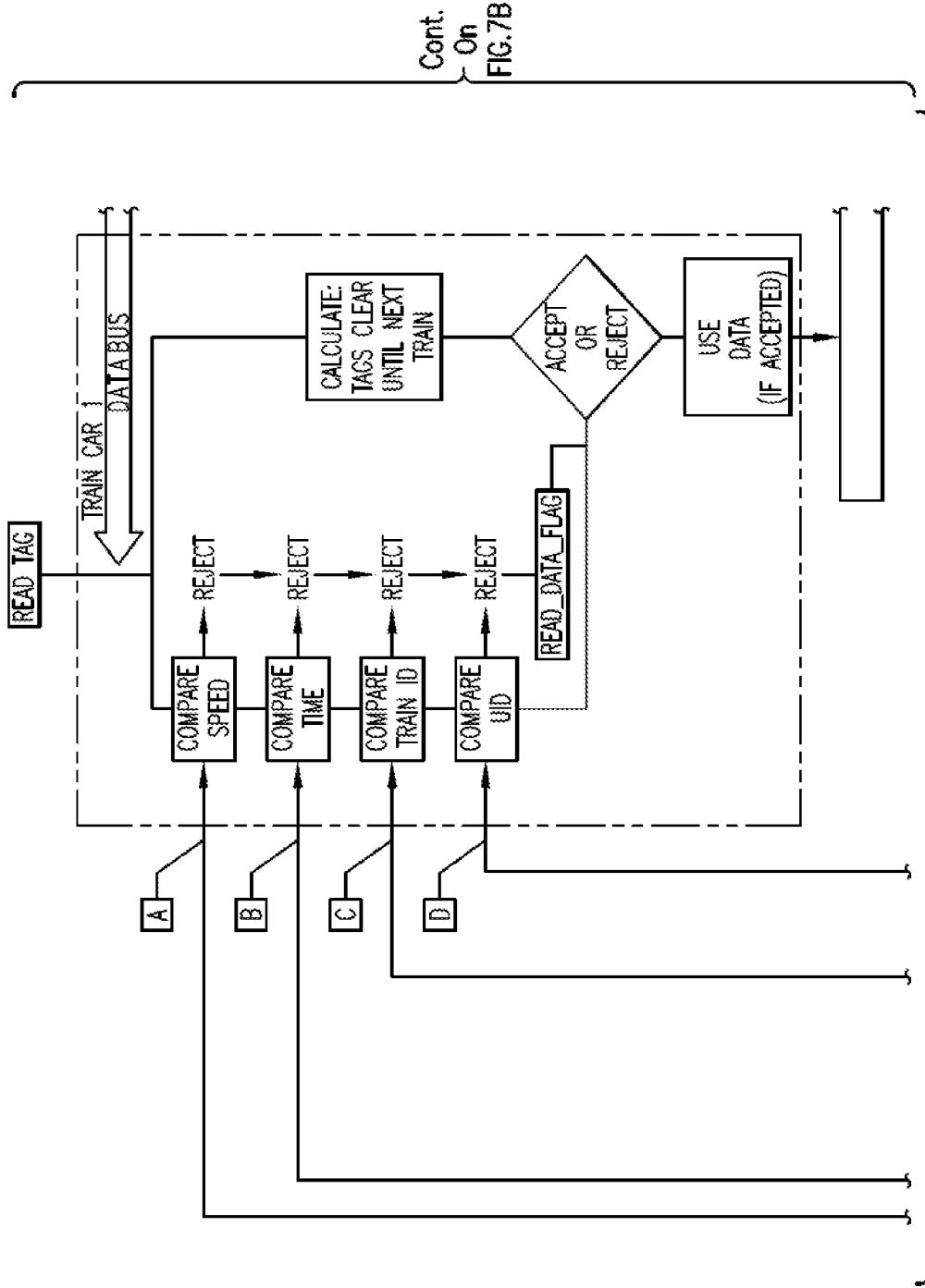

FIG.7A

Cont. on FIG.7C

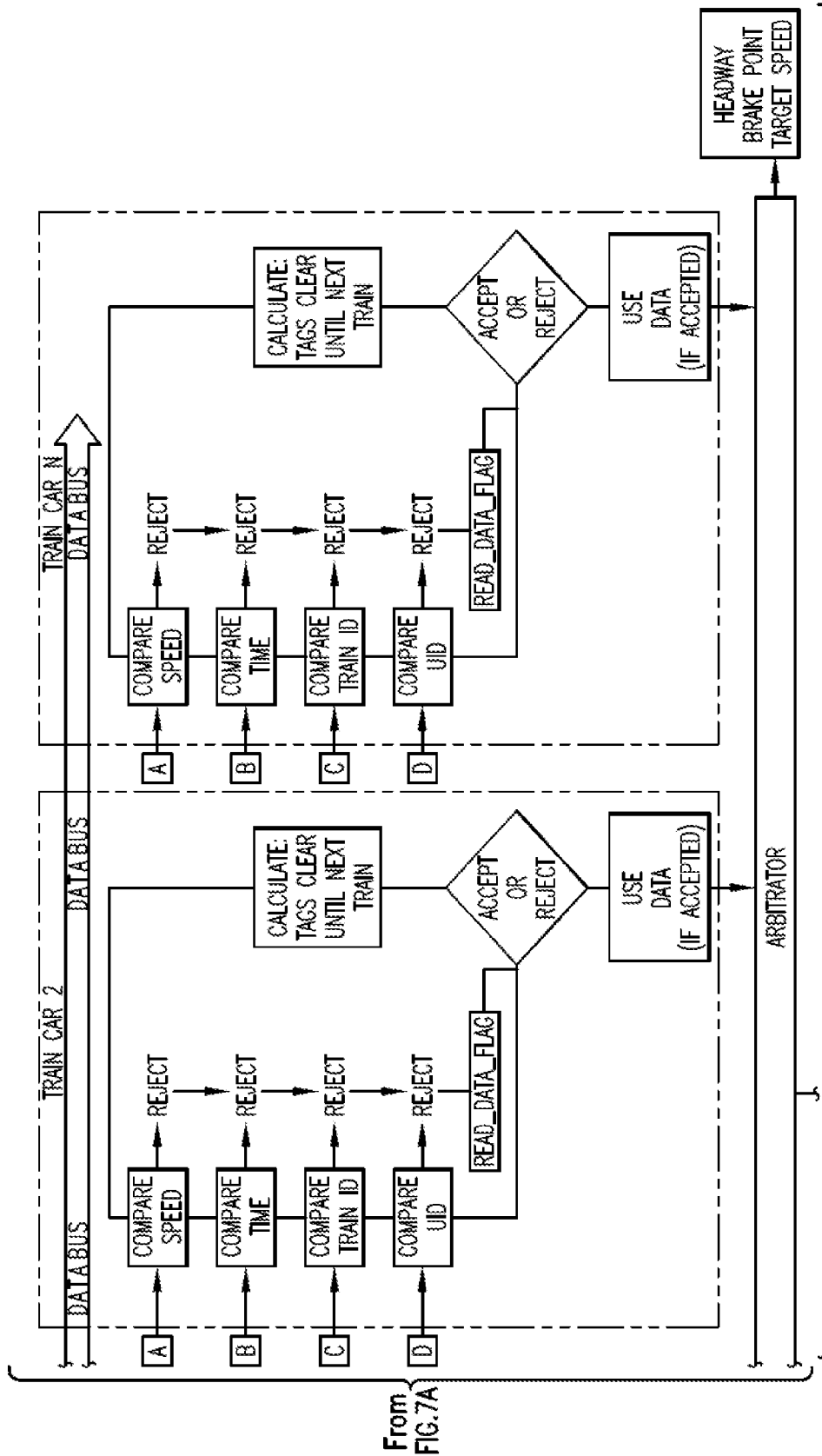
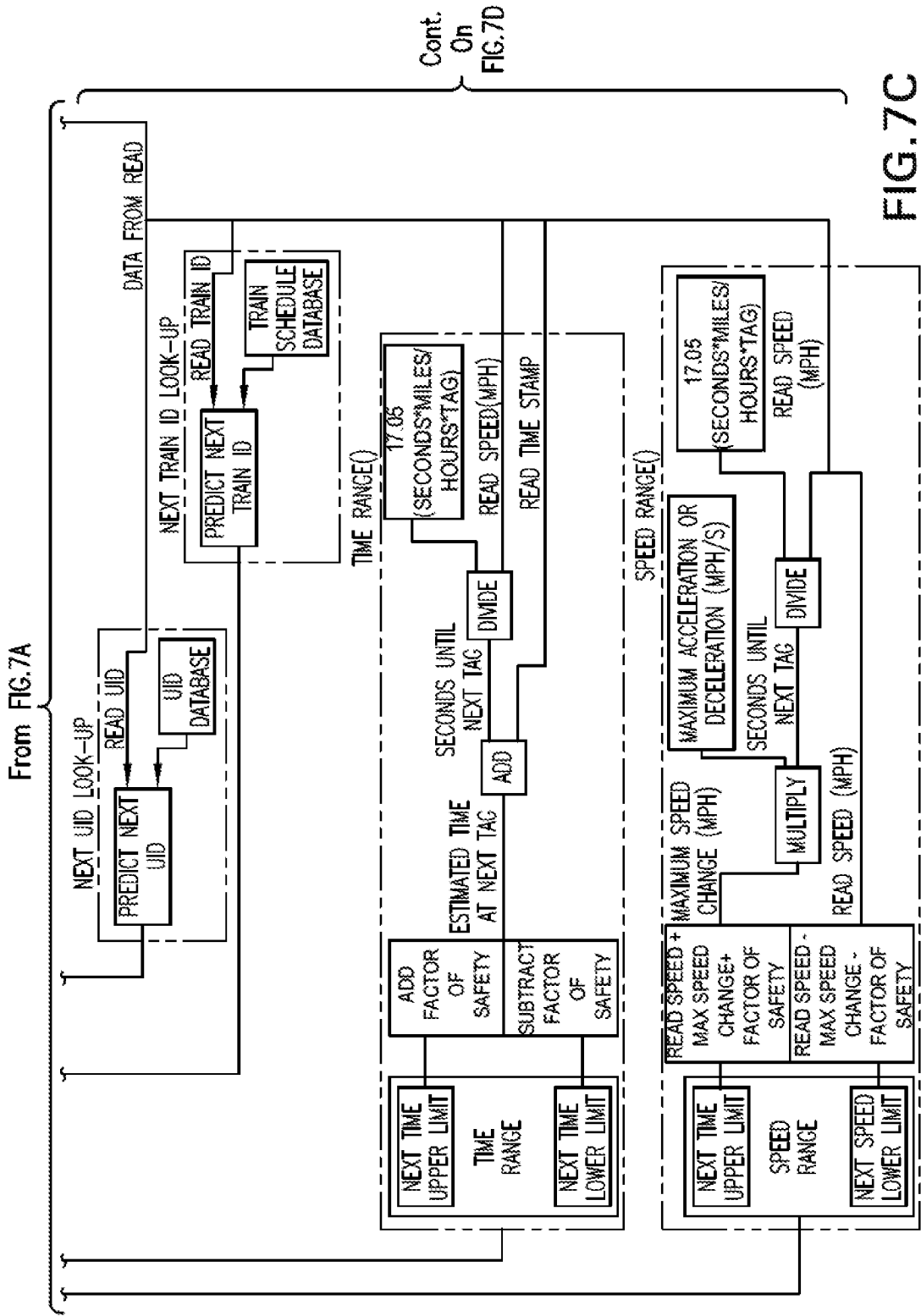

FIG. 7B

Cont. On FIG. 7D

From FIG. 7A



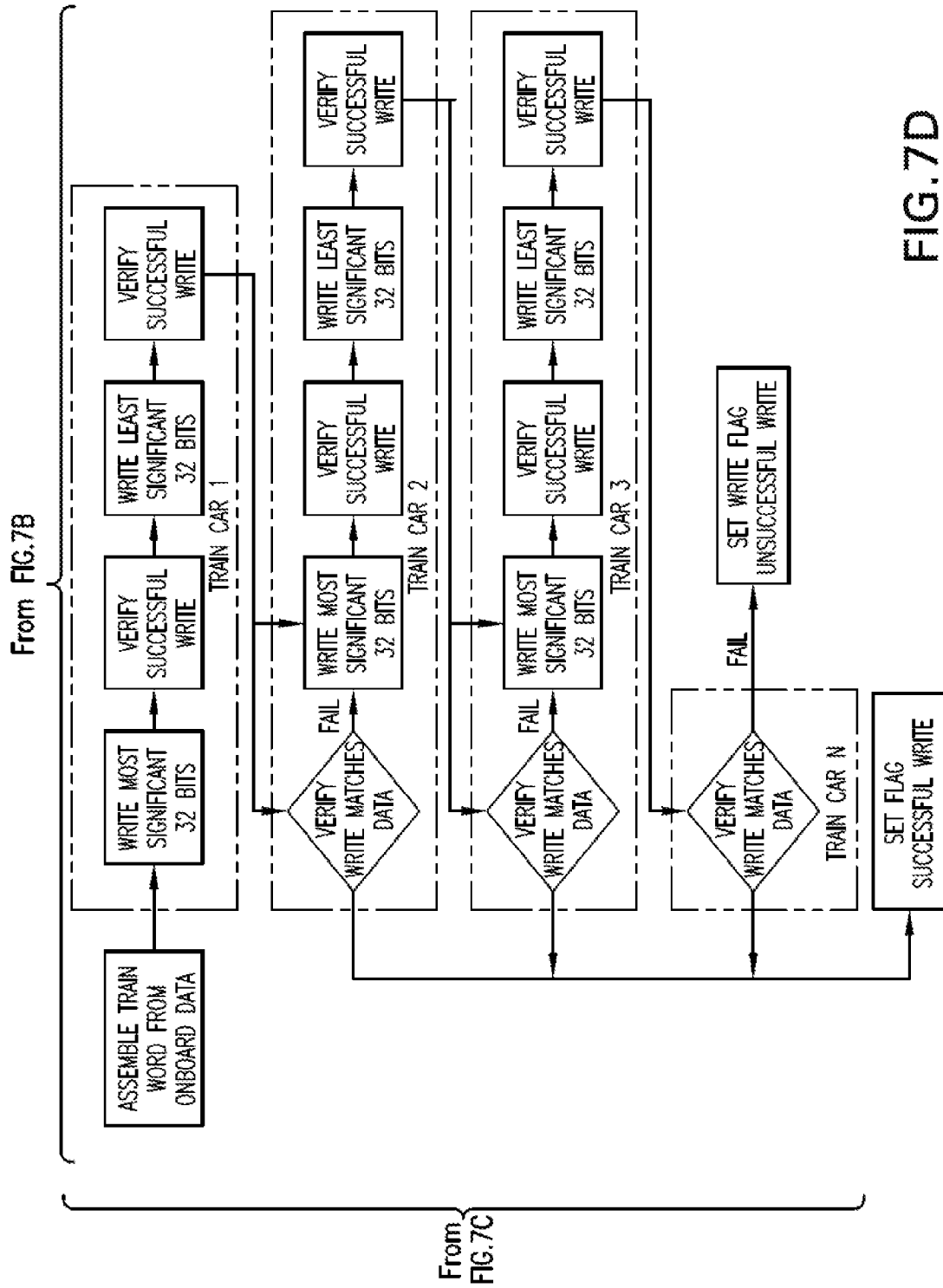

FIG. 7D

INTERNATIONAL SEARCH REPORT

International application No
PCT/IB2019/050531

A. CLASSIFICATION OF SUBJECT MATTER
 INV. B61L3/12 B61L3/00 B61L15/00 B61L23/08 B61L25/02
 B61L25/04 B61L27/00
 ADD.
 According to International Patent Classification (IPC) or to both national classification and IPC

B. FIELDS SEARCHED
 Minimum documentation searched (classification system followed by classification symbols)
 B61L

Documentation searched other than minimum documentation to the extent that such documents are included in the fields searched

Electronic data base consulted during the international search (name of data base and, where practicable, search terms used)
 EPO-Internal, WPI Data

C. DOCUMENTS CONSIDERED TO BE RELEVANT

Category*	Citation of document, with indication, where appropriate, of the relevant passages	Relevant to claim No.
X	US 2008/068164 A1 (CAMPBELL JOHN RICHARD [US]) 20 March 2008 (2008-03-20) abstract; figures paragraphs [0002], [0006], [0007], [0008], [0016] - [0021], [0024] -----	1-21
E	CN 109 305 196 A (UNIV SOUTHWEST JIAOTONG) 5 February 2019 (2019-02-05) the whole document -----	1,12
X,P	CN 109 178 039 A (CHENGDU BAISENSONG SENSOR TECH CO LTD) 11 January 2019 (2019-01-11) the whole document -----	1,12
A	US 8 428 798 B2 (KULL ROBERT C [US]; WABTEC HOLDING CORP [US]) 23 April 2013 (2013-04-23) abstract; figures 1,3 -----	1-21

Further documents are listed in the continuation of Box C.

See patent family annex.

* Special categories of cited documents :

- "A" document defining the general state of the art which is not considered to be of particular relevance
- "E" earlier application or patent but published on or after the international filing date
- "L" document which may throw doubts on priority claim(s) or which is cited to establish the publication date of another citation or other special reason (as specified)
- "O" document referring to an oral disclosure, use, exhibition or other means
- "P" document published prior to the international filing date but later than the priority date claimed

- "T" later document published after the international filing date or priority date and not in conflict with the application but cited to understand the principle or theory underlying the invention
- "X" document of particular relevance; the claimed invention cannot be considered novel or cannot be considered to involve an inventive step when the document is taken alone
- "Y" document of particular relevance; the claimed invention cannot be considered to involve an inventive step when the document is combined with one or more other such documents, such combination being obvious to a person skilled in the art
- "&" document member of the same patent family

Date of the actual completion of the international search 31 May 2019	Date of mailing of the international search report 11/06/2019
--	--

Name and mailing address of the ISA/ European Patent Office, P.B. 5818 Patentlaan 2 NL - 2280 HV Rijswijk Tel. (+31-70) 340-2040, Fax: (+31-70) 340-3016	Authorized officer Robinson, Victoria
--	--

INTERNATIONAL SEARCH REPORT

Information on patent family members

International application No

PCT/IB2019/050531

Patent document cited in search report	Publication date	Patent family member(s)	Publication date
US 2008068164	A1	20-03-2008	NONE

CN 109305196	A	05-02-2019	NONE

CN 109178039	A	11-01-2019	NONE

US 8428798	B2	23-04-2013	
		AU 2010340289	A1 24-11-2011
		BR PI1010174	A2 29-03-2016
		CA 2761014	A1 14-07-2011
		US 2011172856	A1 14-07-2011
		WO 2011084251	A2 14-07-2011
