

(21) Application No 9300970.2

(22) Date of filing 19.01.1993

(30) Priority data

(31) 9200631 (32) 20.01.1992 (33) FR

(71) Applicant

Institut Français du Pétrole

(Incorporated in France)

4, Avenue de Bois Préau, 92502 Rueil Malmaison,
France

(72) Inventors

Philippe Staron
Jean Laurent

(74) Agent and/or Address for Service

Fitzpatrick's
Cardinal Court, 23 Thomas More Street, London,
E1 9YY, United Kingdom

(51) INT CL⁵

G01V 1/40

(52) UK CL (Edition L)

G1G GMB

(56) Documents cited

GB 2235047 A EP 0442812 A1 WO 87/05708 A1
US 5137109 A US 4674591 A

(58) Field of search

UK CL (Edition L) G1G GMB
INT CL⁵ G01V
Online database: WPI

(54) Seismic well source using a reactive mass

(57) The seismic source (5) comprises a closed chamber (6) fastened inside a drill collar (4) of the drill string (1). The section thereof is smaller than the inner section of the drill string, so as to allow free circulation of the drilling fluid. A reactive mass (8) is caused to move within this chamber (6) and along the axis of drill string (1). Hydraulic or electro-mechanical means (14-17) allow a strong alternating force of controlled frequency and duration to be applied to this mass. The energy necessary to the operating thereof may be taken from the fluid current. Drilling a well and performing seismic measurement may be achieved at the same time by means of the source by arranging sensors at the surface and/or in one or several adjacent wells.

FIG. 2

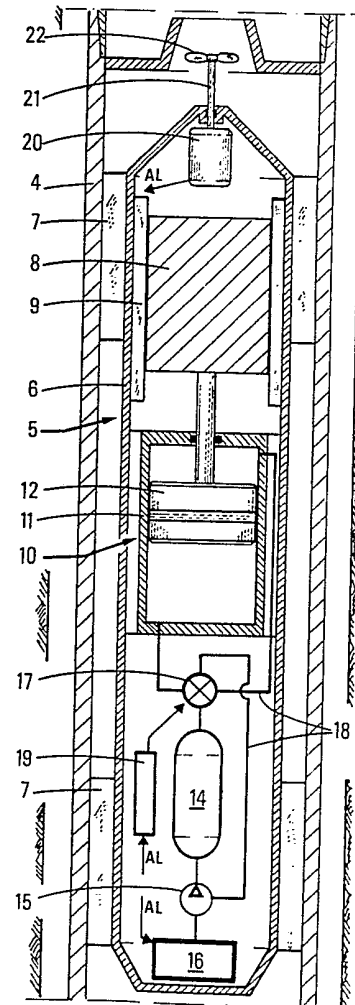

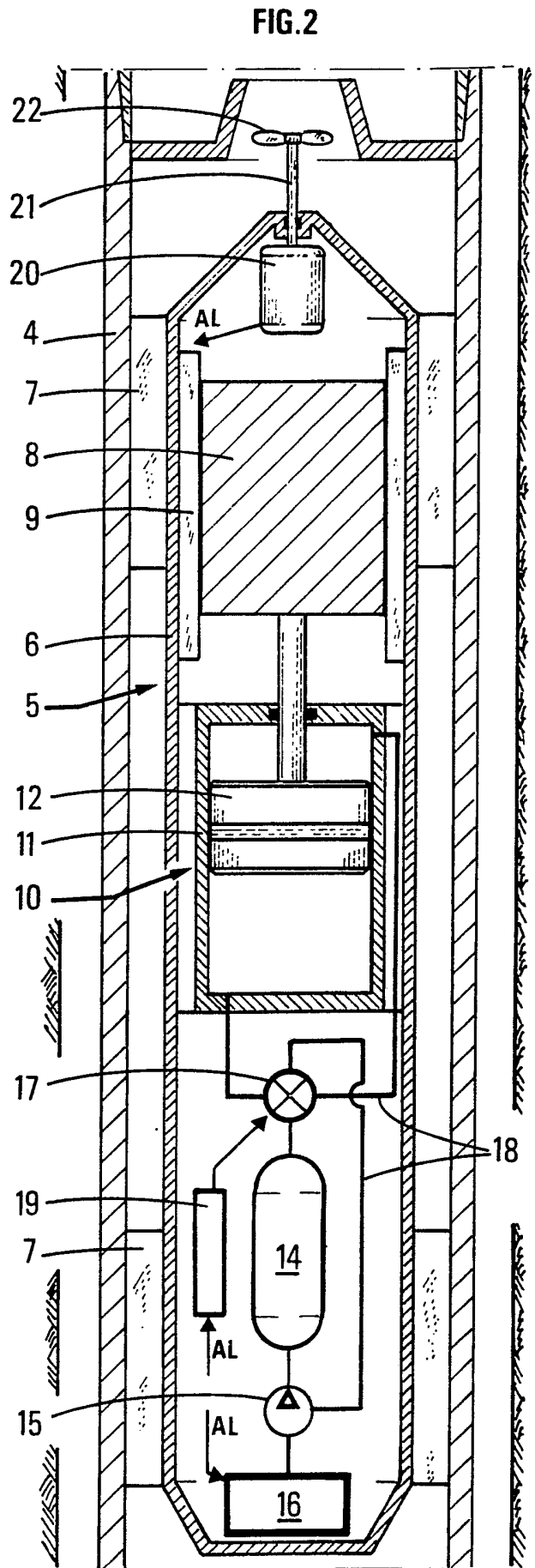
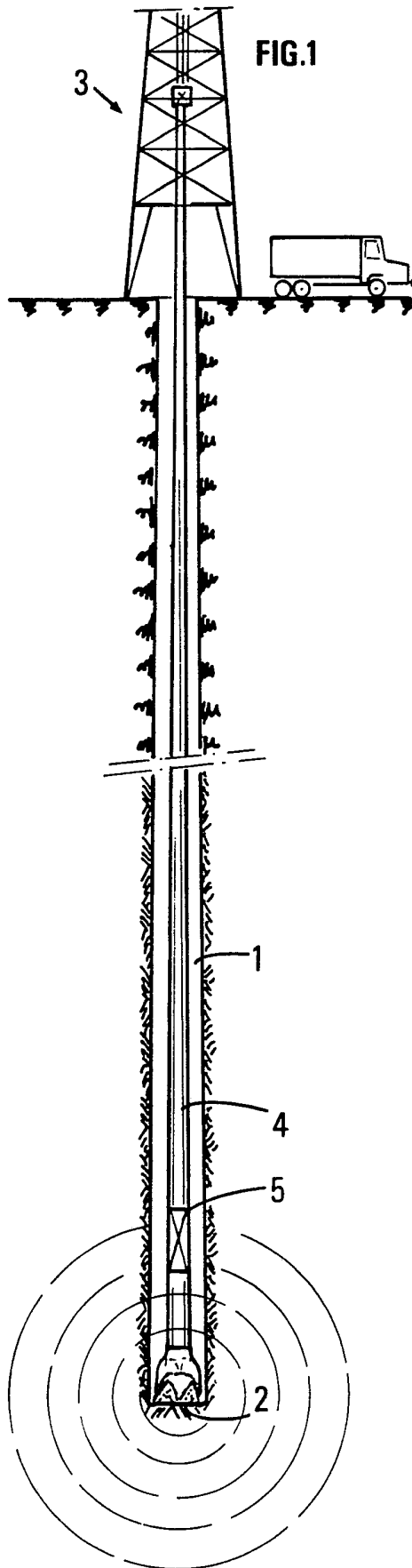

FIG.3

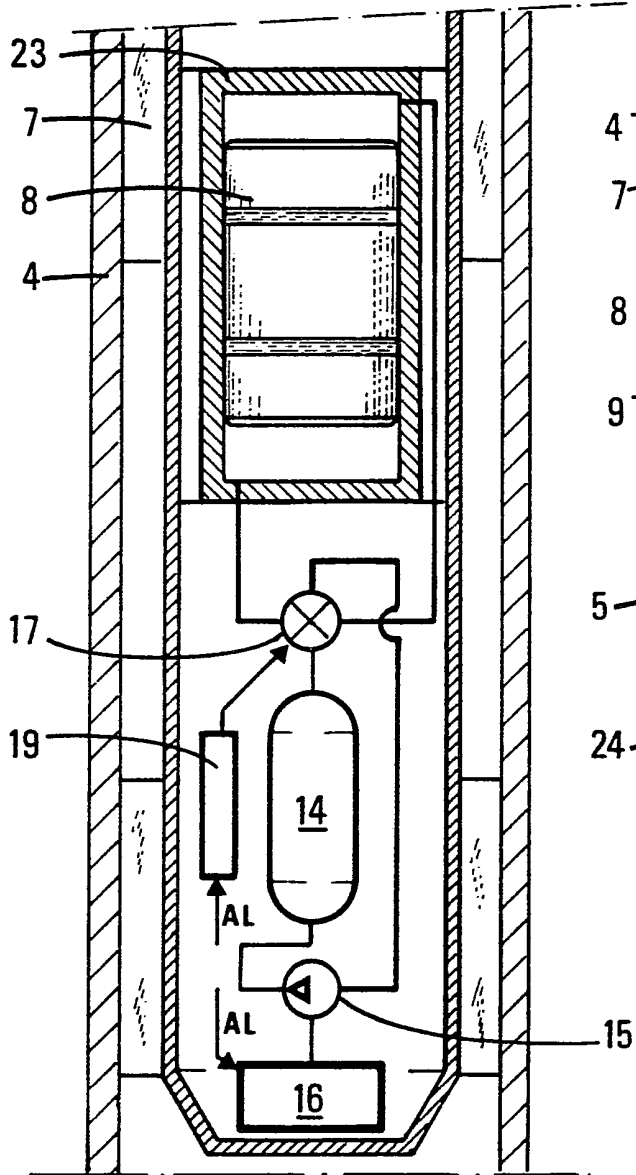
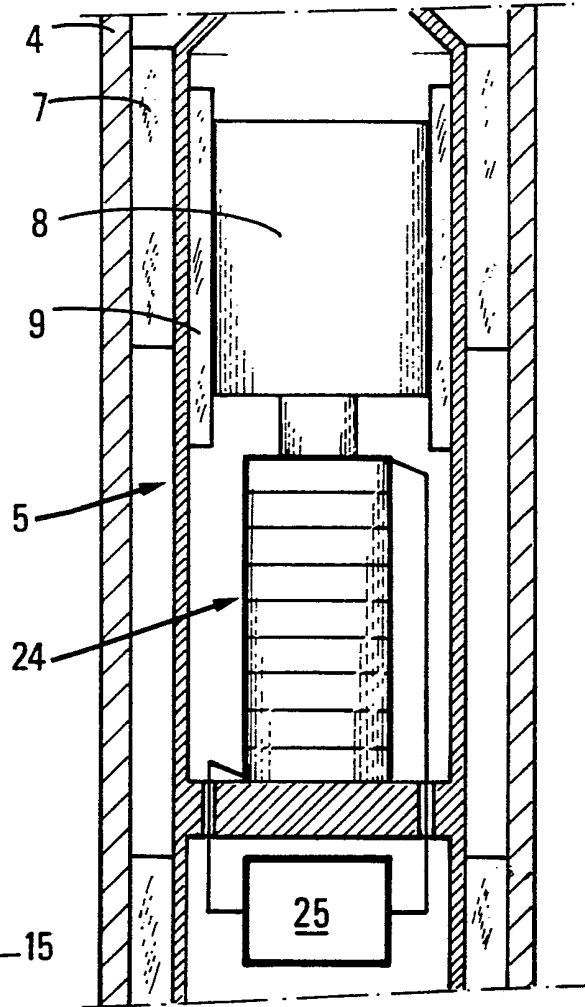

FIG.4



SEISMIC WELL SOURCE
OBJECT OF THE INVENTION

The object of the invention is a seismic well source which may be associated with a drill string. The source according to the invention is particularly adapted to
5 communicate to a drill bit in a well periodic shakes and to apply them to the surrounding formations.

BACKGROUND OF THE INVENTION

There are numerous methods for performing seismic prospecting in formations crossed by a well, including the
10 emission of seismic pulse signals or of vibrational signals by a source lowered into the well, in order notably to avoid the disturbances transmitted by the weathering zone when the waves are emitted at the surface, the reception of the waves reflected by the subsoil discontinuities by means of a
15 reception device located in the well, in another well or at the surface, and the recording thereof. Numerous processings are generally applied to the recordings so as to make them more readable to the interpreter.

Among the numerous emission devices for wells, some
20 have been specially designed to work in relation or in combination with a drill bit. These operations, referred to as MWD operations, allow prospecting operations to be achieved without stopping the drilling of a well and therefore exploration costs to be decreased.

Emission devices are for example known with which the vibrations applied to formations are the "noises" generated by a drill bit operated at the end of a drillstem or drill string. The amplitude of these shakings may vary to a large extent according to the hardness of the formations crossed by the bit. Conventional processing methods are generally very difficult to utilize with the recordings obtained with this type of emission because the characteristics of the source are not well-known. The signal is emitted permanently and no reference instant can be set. Moreover, the frequency spectrum emitted depends on the rotating speed of the bit and on the nature of the beds drilled. In order to know at any time the phase of the signals emitted, it is necessary to have a sensor located close to the drill bit and any transmission channel allowing a signal in phase with the signals emitted to be transmitted to a surface processing equipment. It may be, for example, the transmission of acoustic waves modulated according to the signals to be transmitted, along the fluid contained in the well, as described for example in patent US-4,675,852, or possibly along the pipes of a drill string.

Among well sources, those which transmit, to the formations crossed, seismic impulses generated by shocks of the drill bit on the hole bottom may also be cited, these shocks being isolated or repeated with a determined period. To create these shocks, it is possible to use the surface operating device to exert a momentary traction on the drill

string and to vary momentarily the force of gravity applied onto the bit. The shocks of the drilling head on the hole bottom may also be generated by a percussion drill bit constituted by interposing, between the drilling head and the drill string, a telescopic hydraulic device which may be contracted through a momentary pressure on the string and which, while slackening with a given delay when this pressure is loosened, applies a shock onto the bit. It is also possible to bring about shocks on the drill bit by triggering off "water hammers" through a sudden interruption of the mud flow circulating within the drill string. The main drawback of devices of this type is that, as they are interposed between the drill bit and the drill string, they require modifications in the usual drilling equipment and they have to bear the total weight exerted on the bit, which may be a source of brittleness.

SUMMARY OF THE INVENTION

The seismic well source according to the invention makes it possible to communicate, to a drill bit linked to a surface installation through a drillstem or drill string, an alternating force of controlled frequency, and to communicate it to the formations at the bottom of a well, without requiring any substantial modification in the usual geometry of drilling equipments.

It comprises an elongate closed chamber having a section smaller than the inner section of the drillstem, in

order to allow passage of drilling fluid, this chamber being fastened inside a pipe close to the drill bit, a reactive mass displaceable inside the chamber and along the direction of elongation thereof, and motor means arranged in said chamber for communicating to the reactive mass an alternating force of controlled amplitude and frequency.

According to one embodiment, the means for generating said force comprise, for example, at least one jack with a stationary body with respect to the chamber and a pipe which is fastened to the mass, as well as a hydraulic system communicating with the body of the jack so as to apply the alternating force onto the pipe thereof and onto the reactive mass.

According to another embodiment, the means for generating said force comprise a hollow body fastened inside the chamber, the reactive mass being adapted for sliding in a substantially tight way inside the body, and a hydraulic system communicating with the body on either side of the reactive mass, in order to apply thereto the required alternating force.

The hydraulic system comprises hydraulic circuits containing a fluid, a pump for carrying the fluid into the circuits at a determined pressure, motor means arranged in the chamber to drive the pump and delivery means to supply the fluid under pressure in order to apply the driving alternating force to the reactive mass.

According to another embodiment, electro-mechanical means are used to generate said force and linking means are used to transmit the vibrations generated by the electro-mechanical means to the reactive mass. These means may
5 comprise, for example, piezoelectric elements piloted by an emission assembly or an electro-dynamic vibrator.

According to an advantageous embodiment, the source according to the invention comprises means actuated by a fluid current circulating in the drillstem to produce energy
10 for the running of the motor means, these means comprising for example an electric current generator or a hydraulic energy generator.

The source preferably comprises an electronic piloting assembly for controlling said motor means.

15 Communication means may be used between the chamber and a surface installation, such as elements providing connection through modulated pressure waves.

The source according to the invention is simply inserted inside a drill pipe and it does not interfere in
20 the transmission of the weight applied onto the bit. It is contained in a closed chamber whose section is smaller than the inner section of the pipe to which it is fastened. It does practically not affect the drilling fluid current circulating inside the drill string and does therefore not
25 modify the drilling parameters. It may work permanently, at

determined intervals or on order, by communicating a strong force to the reactive mass inside, a force which is transmitted to the bit through the string. The source may also be totally autonomous and take (by means of a propeller generator for example) the energy necessary for working from the drilling fluid current. In the closed chamber, it is possible to arrange communication means allowing reception, from the surface installation, of orders of triggering and of control of the frequency of the shakings applied and, in return, communication to the surface installation of the working control signals.

Absorption means are preferably interposed on the drill string so as to avoid transmission thereto of at least part of the energy created by the running of the source.

The invention also relates to a method for implementing the seismic source, comprising :

- setting seismic sensors at the surface and/or in at least one well,
- setting the source interposed on an element of the string close to the drill bit,
- drilling a well by means of said drill bit, and
- recording the modes received by the seismic sensors in response to the shakings applied to the formations surrounding the well being drilled.

The method further comprises transmission of signals between the source and a surface installation, for example, to communicate to the latter a time reference relating to the working of the source.

5

BRIEF DESCRIPTION OF THE DRAWINGS

Other features and advantages of the source according to the invention will be clear from reading the description hereafter of embodiments given by way of non limitative examples, with reference to the accompanying drawings in which :

10

- FIG.1 diagrammatically shows a drill rig to which the seismic source according to the invention may be added,

- FIG.2 diagrammatically shows a first embodiment of the source with a reactive mass and a jack,

15

- FIG.3 shows a second embodiment of the source with a reactive mass sliding inside a closed body located in the chamber, and

- FIG.4 shows another embodiment where the force applied to the reactive mass is of piezoelectric origin.

20

DESCRIPTION OF THE PREFERRED EMBODIMENTS

The seismic source according to the invention may be associated (FIG.1) with a string of tubular pipes (drill string) 1 connecting a drill bit 2 to a surface installation

comprising a derrick 3. It is included for example (FIG.2) inside a tubular drill collar 4 of the drill string close to the drill bit. The seismic source 5 is included in an elongate rigid chamber 6 which is fastened to the inner wall of pipe 4 through flanges 7. The outer section of chamber 6 is smaller than the inner section of pipe 4 and the flanges 7 are arranged to allow passage of the drilling fluid which is circulated from the surface towards the drill bit. A reactive mass 8, which may move parallel to the axis of the chamber and of the pipe between longitudinal guide rails 9, is arranged inside the closed chamber. This reactive mass 8 is integral with driving means capable of imparting thereto an alternating force of controlled amplitude and frequency. These means comprise, for example, a jack 10 provided with a cylindrical body 11 oriented along the axis of the chamber, a piston 12 sliding tightly into the body 11 and a pipe 13 making the piston integral with the reactive mass. A hydraulic system is for example used to apply the alternating force onto piston 12 and thus to reactive mass 8. This system comprises a hydraulic accumulator 14, a hydraulic pump 15 to supply fluid under pressure into accumulator 14, an electric motor 16 to drive the pump, a supply valve 17 and lines 18 allowing the fluid under pressure from accumulator 14 to be applied into the cylinder 11 alternately on one side or on the opposite side of piston 12 so as to generate a strong alternating force which is communicated to the reactive mass 8. An electronic assembly 19 is also arranged inside the chamber to pilot the delivery

of fluid by valve 17 so that the frequency of the alternating force applied at any time to the mass is well-defined or that this frequency follows in time a well-defined variation law. An electric generator such as an alternator 20 is for example arranged in the chamber. Its axis 21 is oriented parallel to that of the drill pipe and it goes through the wall of the chamber. It is connected to a propeller 22 which is driven in rotation by the drilling fluid that is circulated inside towards the drill bit.

10 Absorption means (of the type known by specialists as shock absorber for example) are interposed on the drill string above the source to prevent transmission, to the string, of the seismic energy generated by the working of the source.

15 Communication between the source and the surface installation may be achieved with a well-known technique by means of modulated or coded acoustic waves which are propagated along the well in the drilling fluid. To that end, the electronic assembly 19 is connected to an assembly
20 for the emission-redption of acoustic signals (not shown) comprising transductor means arranged outside the chamber.

 However, the source may also work automatically either permanently, with an uninterrupted chain of emission sequences where the emitted frequency varies according to a
25 predetermined variation law, or discontinuously, with successive emission periods where the emission frequency is

fixed or variable, separated by time intervals during which the emission is interrupted.

The means for applying the force and the reactive mass are selected so as to develop and to transmit to the bit a force strong enough. An adequate selection makes it possible to obtain an alternating force that is properly proportionate to the weight of the drill string weighing on the drill bit, so as to consequently generate a strong alternating shake in the formations in contact with the bit. If the mass of the drill string is about 10^4 kg, the hydraulic system is adapted to generate an alternating force of about $2 \cdot 10^4$ Newton.

According to another embodiment (FIG.3), the reactive mass 8 is adapted to slide tightly into a cylindrical cavity inside a hollow body 23 integral with chamber 6 and the hydraulic circuits connect the two opposite ends of the hollow body 23 on either side of the mass with supply valve 17.

According to another embodiment, the reactive mass (FIG.4) is in contact with an array 24 of piezoelectric pellets piled and connected in series or in parallel, depending on the case, to the terminals of an appropriate electric generator 25. Transmission of the force may be achieved through direct mechanical coupling between the block and the reactive mass, or by way of hydraulic linking

means comprising hydraulic circuits and a coupling jack (not shown).

According to another embodiment, the electric generator 20 may be replaced by a hydraulic generator directly driven
5 by propeller 22 in order to charge accumulator 14 and to actuate the reactive mass.

Without departing from the scope of the invention, the hydraulic or piezoelectric motor means described above may be replaced by any other means for creating an alternating
10 force.

With the seismic source described above, seismic exploration operations can be performed while drilling a well. An array of seismic sensors is arranged at the surface and/or in another well, and the waves which they receive in
15 response to the shakings applied onto the formations surrounding the wellbore bottom through the source are recorded.

We claim :

1) A seismic well source for communicating, to a drill bit connected to a surface installation by a tubular drill string (1), an alternating force of controlled frequency, comprising an elongate closed chamber (6) having a section smaller than the inner section of the drill string so as to allow passage of drilling fluid, this chamber being fastened inside a pipe (4) close to the drill bit (2), a reactive mass (8) displaceable inside the chamber (6) and along the direction of elongation thereof, and motor means arranged in said chamber to communicate to the reactive mass an alternating force of controlled amplitude and frequency.

2) A seismic source as claimed in claim 1, wherein the motor means for generating said force comprise at least one jack (10) with a stationary body with respect to chamber (6) and a pipe which is fastened to the mass, as well as a hydraulic system (14-17) communicating with the jack to apply to the pipe of the jack said alternating force.

3) A seismic source as claimed in claim 1, wherein the motor means for generating said force comprise a hollow body (23) fastened inside the chamber (6), the reactive mass (8) being adapted to slide in a substantially tight way inside the body, and a hydraulic system (14-17) communicating with the body (23) on either side of the reactive mass (8), to apply thereto said alternating force.

4) A seismic source as claimed in claim 2 or 3, wherein the hydraulic system comprises hydraulic circuits containing a fluid, a pump (15) for supplying the fluid into the circuits at a determined pressure, motor means (16) arranged
5 in the chamber for driving the pump and delivery means (17) to supply the fluid under pressure so as to apply to the reactive mass (8) the alternating force.

5) A seismic source as claimed in claim 1, comprising electro-mechanical means (24) to generate said force and
10 linking means to transmit the vibrations generated by the electro-mechanical means to said reactive mass.

6) A seismic source as claimed in claim 5, wherein the electro-mechanical means comprise piezoelectric elements piloted by an emission assembly.

7) A seismic source as claimed in claim 5, wherein the
15 electro-mechanical means comprise an electro-dynamic vibrator.

8) A seismic source as claimed in any one of the previous claims, comprising means (20) operated by a fluid
20 current circulating in the drill string to produce energy for the running of the motor means.

9) A seismic source as claimed in claim 8, wherein the means (20) for producing energy comprise an electric current generator.

10) A seismic source as claimed in claim 8, wherein the means (20) for producing energy comprise a hydraulic energy generator.

5 11) A seismic source as claimed in any one of the previous claims, comprising an electronic piloting assembly for controlling said motor means.

12) A seismic source as claimed in any one of the previous claims, comprising communication means between said chamber and a surface installation.

10 13) A seismic source as claimed in the previous claim, wherein the communication means comprise elements providing connection through modulated pressure waves.

15 14) A seismic source as claimed in any one of the previous claims, comprising interposed absorption means to prevent transmission, to the drill string, of at least part of the energy generated through the working of the source.

15) A method for implementing the seismic source as claimed in any one of claims 1 to 14, comprising :

- 20
- setting seismic sensors at the surface and/or in at least one well,
 - setting the source in the pipe interposed on the drill string close to the drill bit,
 - drilling a well by means of said drill bit, and

- recording the waves received by the seismic sensors in response to the shakings applied to the formations surrounding the well during drilling.

5 16) A method as claimed in claim 15, comprising the transmission of signals between the source and a surface installation.

17) A seismic well source substantially as hereinbefore described with reference to figure 2 of the drawings.

18) A seismic well source substantially as hereinbefore described with reference to figure 3 of the drawings.

19) A seismic well source substantially as hereinbefore described with reference to figure 4 of the drawings.

20) A method substantially as hereinbefore described with reference to figures 1 to 4 of the drawings.

**Patents Act 1977
Examiner's report to the Comptroller under
Section 17 (The Search Report)**

Application number

GB 9300970.2

Relevant Technical fields

(i) UK CI (Edition L) G1G (GMB)

(ii) Int CI (Edition 5) G01V

Search Examiner

D J HARRIS

Databases (see over)

(i) UK Patent Office

(ii) ONLINE DATABASE: WPI

Date of Search

9 MARCH 1993

Documents considered relevant following a search in respect of claims ALL

Category (see over)	Identity of document and relevant passages	Relevant to claim(s)
Y	GB 2235047 A (ATLANTIC RICHFIELD) See abstract, page 1 paragraph 1 and page 3 paragraph 1	1 at least
Y	EP 0442812 A1 (SCHLUMBERGER)	1 at least
&	US 5137109 (SCHLUMBERGER)	
Y	WO 87/05708 A1 (CHEVRON)	1 at least
Y	US 4674591 (URS)	1 at least



Category	Identity of document and relevant passages	Relevant to claim(s)

Categories of documents

X: Document indicating lack of novelty or of inventive step.

Y: Document indicating lack of inventive step if combined with one or more other documents of the same category.

A: Document indicating technological background and/or state of the art.

P: Document published on or after the declared priority date but before the filing date of the present application.

E: Patent document published on or after, but with priority date earlier than, the filing date of the present application.

&: Member of the same patent family, corresponding document.

Databases: The UK Patent Office database comprises classified collections of GB, EP, WO and US patent specifications as outlined periodically in the Official Journal (Patents). The on-line databases considered for search are also listed periodically in the Official Journal (Patents).