

No. 852,934.

PATENTED AUG. 13, 1907.

J. L. PERKINS.
TROLLEY CATCHER AND RETRIEVER.

APPLICATION FILED FEB. 21, 1906.

3 SHEETS—SHEET 1.

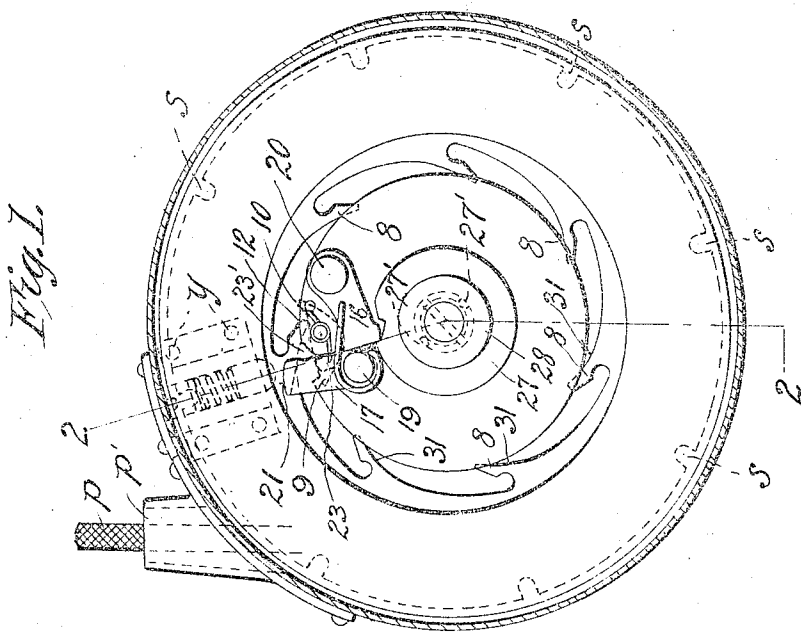
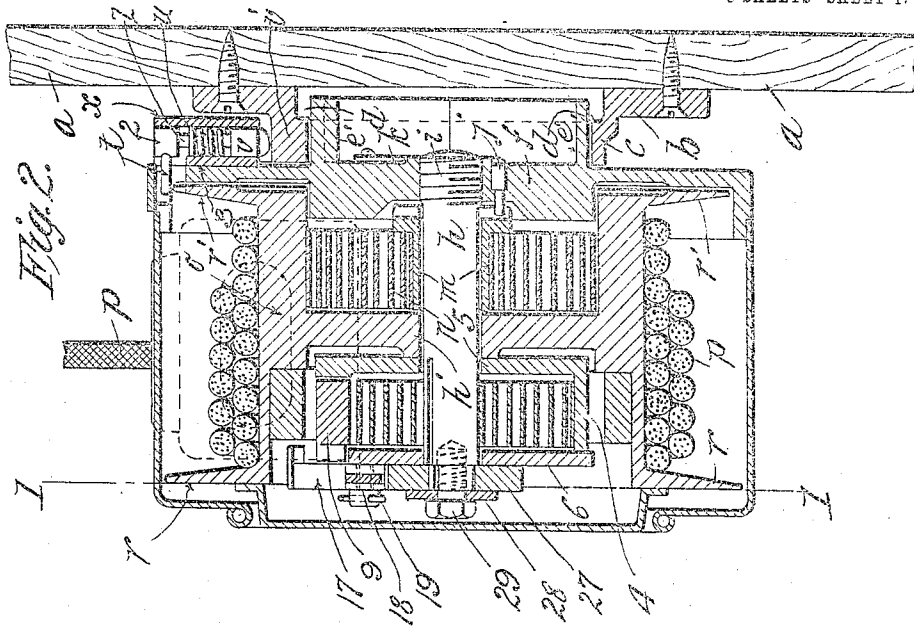

Witnesses:
H. P. Sprague
C. H. Sealhorn

Inventor:
Julian L. Perkins
by Chapin & Co.
Attorneys.

No. 862,934.

PATENTED AUG. 13, 1907.

J. L. PERKINS.
TROLLEY CATCHER AND RETRIEVER.

APPLICATION FILED FEB. 21, 1906.

3 SHEETS—SHEET 2.

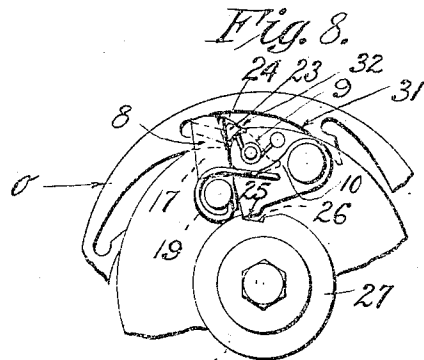
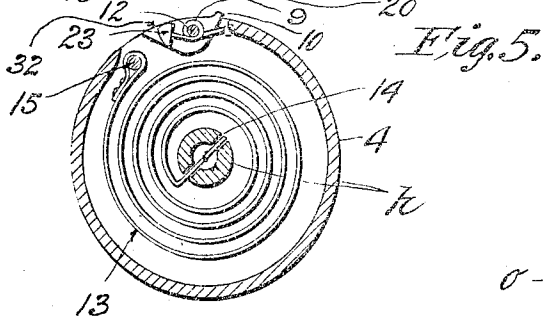
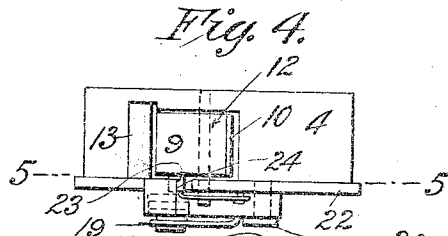
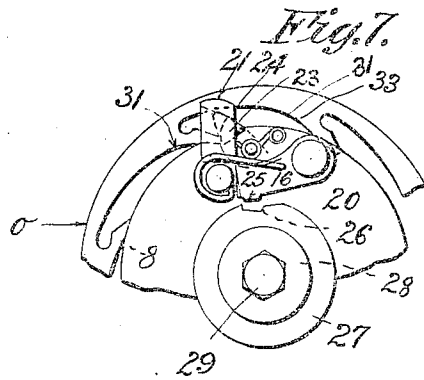
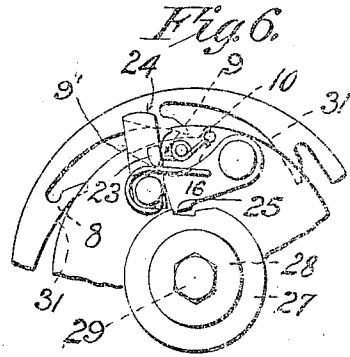
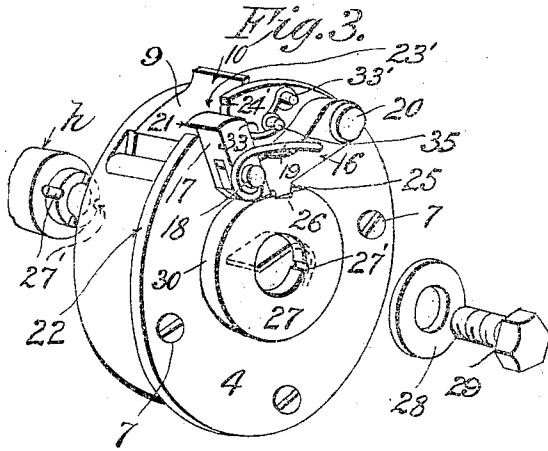

Witnesses:
H. L. Sprague
E. H. Seaborn

Inventor:
Julian L. Perkins
by Chapman & Co.
Attorneys.

J. L. PERKINS.
TROLLEY CATCHER AND RETRIEVER.

APPLICATION FILED FEB. 21, 1906.

3 SHEETS—SHEET 3.

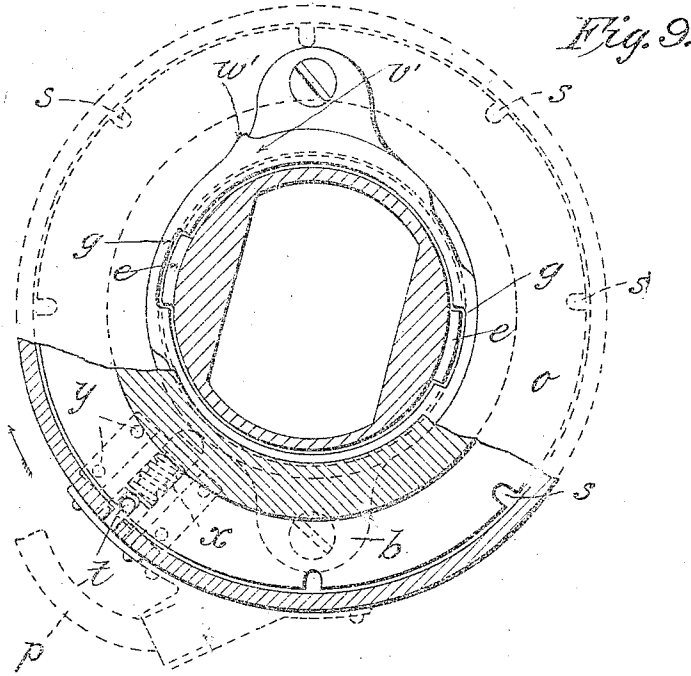

Fig. 9.

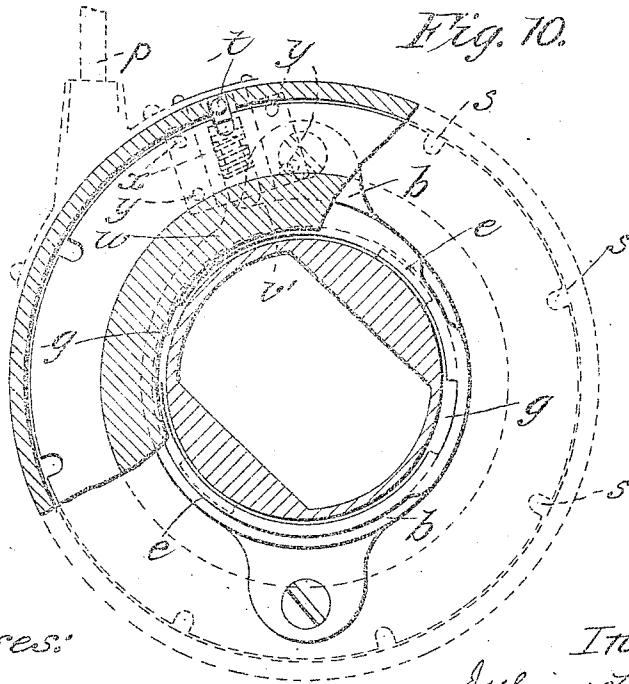

Fig. 10.

Witnesses:
H. L. Sprague
E. H. Sealover

Inventor:
Julian L. Perkins
 by *Chapin & Co.*
Attorneys

UNITED STATES PATENT OFFICE.

JULIAN L. PERKINS, OF SPRINGFIELD, MASSACHUSETTS.

TROLLEY CATCHER AND RETRIEVER.

No. 862,934.

Specification of Letters Patent.

Patented Aug. 13, 1907.

Application filed February 21, 1906. Serial No. 302,197.

To all whom it may concern:

Be it known that I, JULIAN L. PERKINS, a citizen of the United States of America, residing at Springfield, in the county of Hampden and State of Massachusetts, have invented new and useful Improvements in Trolley Catchers and Retrievers, of which the following is a specification.

This invention relates to trolley-catchers and retrievers for automatically preventing the trolley-head or pole from injuring the net-work of overhead wires when the trolley-wheel jumps the wire and is suddenly thrown upward by the expansive force of the spring on the car which controls the trolley-pole; and its object is to provide a construction which will permit the trolley-pole to follow any unevenness of the trolley-wire or movements of the car, and at the same time if the pole should accidentally leave the wire to quickly retrieve or draw the same back before any injury would be done to the overhead wire construction.

A further object is to provide a construction whereby one spring will allow the trolley-rope to work freely up and down with the movement of the pole, and if the trolley-wheel should accidentally leave the wire to bring into operation a stronger spring that will instantly draw the pole back again below the horizontal plane of the overhead wires.

A still further object is to provide an automatic catch or stop that will, when the trolley-catcher and retriever are placed in position on the car, release the winding-drum so that the trolley-rope will freely follow the movements of the pole and will automatically lock the drum against rotation when the winding and retrieving device is removed from the car in order to prevent the drum from winding the rope onto the same and allowing the device to fly up against the hand of the conductor. This automatic catch also locks the device in place on the car as described in detail below.

In the accompanying drawings forming part of this application, Figure 1 is a sectional side elevation of the catcher and retriever on line 1—1 Fig. 2, with the closing cap removed and showing the automatic lock for the winding-drum or barrel which contains the stronger spring. Fig. 2 is a vertical section on the line 2—2 of Fig. 1. Fig. 3 is a perspective view of a barrel which contains the stronger spring for retrieving the trolley-pole and also showing the automatic locks or pawls mounted thereon. Fig. 4 is a top plan view of Fig. 3. Fig. 5 is a vertical sectional view on line 5—5, Fig. 4. Figs. 6, 7, and 8 show the various positions of the automatic lock during the retrieving action of the device. Fig. 9 is a partial sectional view of the rear side of the device showing the automatic catch in dotted lines for preventing the winding-drum from rotating when the retriever is removed from the car. This figure indicates the position of the catcher and retriever when the same is first placed on the holding-ring on the car, and

before it is rotated in the direction of the arrow to lock the same in place. Fig. 10 indicates the position of the trolley-catcher and retriever after the same is locked in position on the holding-ring on the car by the automatic catch.

Referring to the drawings in detail, *a* designates a portion of the car to which the trolley-catcher and retriever are attached; *b* designates the holding-ring on the car having a rim or offset portion *c*. The interior of this portion *c* has a locking edge or channel *d* for receiving the holding lugs *e* on the rim *c* on the rear casting *f*. These lugs *e* are adapted to be passed through the cut-out portions or channel openings *g* in the holding-ring *b* leading to the locking edge or channel *d*. This rear casting *f* has rigidly secured at its center a bolt or stud *h* which is securely screwed into the casting *f* by means of the threads *i*, as shown in Fig. 2.

Extending loosely through the casting *f* is a locking-pin *j* which has secured at its outer end a holding or retaining spring *k* in order to permit the pin *j* to be readily withdrawn from the sleeve *m*. This sleeve is loosely mounted on the bolt or stud *h*. A spring *n* is attached at its inner end to the sleeve *m* and its outer end is attached to a rope winding-drum *o* for the trolley-rope *p* which plays through an opening *p* in the upper part of the casing. The winding-drum *o* has a bearing on the stud at *h* and carries at its outer edge two guide flanges *r* and *r'*.

Cut at equi-distant points in the flange *r* of the winding-drum *o* are notches *s* for receiving the holding or locking-pin *t* to prevent the rotation of the drum *o* when the device is removed from the car, and which is operated by the spring *u* to normally draw the pin *t* downward into the notches *s*; but when the sliding-bolt *v* engages the thickened portion *v'* (see Figs. 2 and 9) of the cam-shaped ring *w* on the holding-ring *b*, the pin *t* is elevated and raised clear of the notches *s* allowing the drum *o* to rotate freely.

The sliding-bolt *v* and spring *u* are inclosed in a barrel *x* on the rear portion of the casting *f*, (as shown in Figs. 1, 2, and 10,) by means of screws or rivets *y*. Integral with the sliding-bolt *v* is a stem *z* attached to the head 2 which carries the pin *t*. Immediately above the spring *u* is a ring 3 for preventing the spring *u* from rising. It is thus seen that the rounded lower end of the sliding-bolt *v* (when in engagement with the thickened portion *v'* of the ring *w*) is raised and frees the pin *t* from the notches *s* permitting the drum *o* to revolve. It will be noticed that this thickened part *v'* of the holding-ring has a lug or boss *w'* (see Fig. 9) over which the sliding-bolt *v* snaps. This lug or boss *w'* securely holds the device in place on the car. The bolt *v* is snapped over the part *w'* by giving the device a quick rotary movement and is released therefrom by a quick movement in the opposite direction.

Loosely mounted on the outer end of the bolt or stud

h is a spring barrel 4 composed of a cup or U-shaped part 5 and a plate 6, the latter being secured to the cup or U-shaped part 5 by the screws 7 (see Fig. 3).

On the inner surface of the rope winding-drum o are cut a series of inclined holding ratchets 8 which, normally, when the trolley-rope plays freely up and down in unison with the movement of the car lightly strike the S-shaped locking-pawl 9 on the upturned end 10 thereof. The pawl 9 is pivotally mounted in the spring barrel 4 on the pin 12.

A strong spring 13 within the barrel 4 has its bent inner end attached to the bolt or stud h by means of a slot 14 in the outer end of the stud h while its outer end is attached to the barrel 4 by a pin or stud 15. This spring 13 is much stronger than the spring n .

Pivotally secured on the outer face of the barrel 4 is a pawl or trigger 16 to which is pivotally secured a spring-retained piece 17 by means of the pivot 18 and spring 19. This piece 17, as shown, stands nearly at right angles to the pawl 16 which is pivotally secured to the barrel 4 by a pin 20. The spring-retained piece 17 has an overhanging lip 21 to engage the edge 22 of the barrel.

The S-shaped pawl 9 carries integral with it a lug 23, (as clearly shown in Figs. 4, 6, 7 and 8) which works in a cut-out opening 23' (see Fig. 3) of the barrel 4. The upper curved surface of the lug 23 is adapted to engage the overhanging lip 21 at the point 24 (see Fig. 4) when the pawl 9 is thrown upward into engagement with one of the ratchets 8 on the winding-drum o (see Fig. 7). This lug, by its engagement with the part 24, retains the parts 16 and 17 in the elevated position shown.

Normally, when the trolley-rope plays freely up and down the pawl 9 lies in the position shown in Fig. 6, the upturned part 10 thereof being lightly struck by the end of the ratchets 8 on the rotating drum o but not hard enough to throw the end 9' of the pawl 9 into engagement with the ratchets 8. However, should the trolley-head accidentally leave the wire, thus causing the drum o to rotate much faster than its normal speed, the upturned part 10 of the pawl 9 would receive a sharp, quick blow from the ratchets 8 on the rotating drum causing the pawl 9 to be instantly thrown upward into locking engagement with the ratchets 8, as clearly shown in Fig. 7; the lug 23 will at the same time come into engagement with the spring-retained piece 17 on the overhanging lip 21 at the point 24.

When the parts are in this position, the tension of the strong spring 13 within the barrel 4 is thrown onto the winding-drum o giving it a quick rotary movement in the direction opposite to that when the trolley-wheel leaves the wire and with the tension of the comparatively weak spring n which controls the winding-drum o . The barrel 4 and the drum o being thus locked together make one or more complete revolutions in the opposite direction with the parts in position, as shown in Fig. 7, thus instantly drawing the trolley rope back before the pole can strike any of the overhead wires. In practice, the barrel 4 is wound up so that the drum o makes four complete revolutions in the opposite direction to draw in the trolley rope.

It will be noticed that a locking-lug 25 is integral with the pawl 16. This lug, in its normal position, when the car is running, rests in the notch 26 of a

holding-disk 27 which is secured to the bolt or stud h by means of a washer 28 and a set-screw 29, and prevented from rotating by two holes 27' half of which is in the disk 27, as shown in Fig. 3. A pin is inserted in this hole 27' to lock the disk 27 to the bolt h .

After the parts have been thrown into the position shown in Fig. 7, the pawl 16 and the spring-retained piece 17 remain in the position as shown in Fig. 7, and as the barrel 4 is rotated one or more revolutions in the reverse direction in order to draw in the trolley-rope, the lug 25 on the pawl 16 is held from engaging the outer surface 30 of the holding washer 28 on account of the lug 23 being in engagement with the part 24 and retains the same in this position until one or more revolutions in the reverse direction are completed, depending upon the amount the spring 13 is wound, when it drops by gravity into contact with the outer surface 30 of the holding disk 27; then the shoulders 31 on the rear of the ratchet teeth 8 engage the inclined surface 32 on the rear side of the pawl 9 forcing the pawl 9 downward against the tension of the spring 19, which connects the parts 16 and 17. During this operation the lug 23 on the pawl 9 passes by the temporary holding point 24 on the lip 21 on the piece 17.

The length of the pawl 9 and the distance between the holding ratchets 8 on the drum o is such that in the normal up and down operation of the trolley-rope, the pawl 9 will have time to be forced back below the ratchets 8, without being caught, by the light spring 33. This spring has one end attached to the lug 23 and its opposite end to a stud or screw 33', while its middle portion is coiled one or more times around the pin 35, as clearly shown in Fig. 3. It is to be understood that this spring 33 normally keeps the S-shaped locking-pawl 9 in the position shown in Fig. 5 but permitting the ratchets 8 to lightly strike the end 10 without locking the same to the drum o . When a sudden upward movement of the pole occurs the pawl 9 becomes locked with the first holding ratchet 8. The opening 23' prevents the lug 23 from rising only a certain distance, the lip 21 allowing the lug 23 to pass when the parts are locked together. The spring 13 in the barrel 4 draws the rope in until the lug 25 drops into contact with the disk 27; the part 16 falling by gravity. The amount that the spring in the barrel 4 draws the rope in below the trolley-wire depends upon the degree of tension placed thereon by the conductor, as stated below.

In the operation of the device, the trolley-rope plays freely up and down according to the movements of the trolley-pole, the spring n not being strong enough to pull the trolley-head or wheel off from the overhead wire, but should a sudden upward movement of the trolley-pole occur, as when it suddenly leaves the overhead wire, the upturned part 10 of the locking-pawl 9 will be given a sudden blow and instantly the free end of the S-shaped locking-pawl 9 will be thrown upward into the path of the ratchets 8, as shown in Figs. 5, 7, and 8, thus locking together the spring-barrel 4 and the winding-drum o , whereby the spring 13 immediately exerts its expansive force together with that of the weaker spring n , to draw in the rope p . It is to be understood that the spring 13 is wound or placed under tension before the car starts or whenever

the trolley flies off and is held from rotating the barrel 4 backwards by the lug 25 engaging the notch 26 in the disk 27. At the moment that the locking-pawl 9 is thrown into locking engagement with the ratchet 8, the lug 25 leaves the notch 26, and the pawl 9 with its lug 23 thereon passes by the lip 21 of the piece 17. The parts remain in this position until the spring barrel 4 makes one or more revolutions in the direction opposite to that given to it by the trolley pole flying above the trolley-wire, for drawing in the trolley-rope *p*, and at the end of one or more revolutions, according to the number of times that this spring 13 is wound up by the conductor. The part 16, at the end of one or more revolutions, drops back by gravity into contact with the outer surface 30 of the holding disk 27. It is to be understood that at this point the spring 13 has become so nearly unwound that the part 16 can drop back by gravity into the notch 26. The inclined shoulders 31 on the ratchets 8 then strike the part 32 of the pawl 9 and the lug 23 is forced against the overhanging lip 21 and snaps the locking-pawl 9 against the tension of the spring 19 back into its initial position, as shown clearly in Figs. 3 and 4. This operation is accomplished by the spring *n* revolving the drum *o* in the normal direction, that is to wind the rope *p* onto the drum *o*. After this operation occurs, the conductor grasps the trolley-rope *p* drawing it upward one or more revolutions for the purpose of re-winding the spring 13, until the lug 25 drops into the notch 26; the trolley-rope is then free to work up and down against the tension of the weaker spring *n* thus permitting the conductor to again place the trolley-head in position on the overhead wire when the device is again ready for another series of operations. It should be stated that before the conductor winds the spring 13 in the barrel 4, it is necessary for him to give a quick upward pull on the rope *p* for the purpose of engaging the pawl 9 with the ratchet 8, then by a steady upward pull on the rope *p* the barrel 4 and drum *o* can be given one or more revolutions as may be necessary to place the spring 13 under the required tension. The lug 25, at the end of each revolution, in winding the spring 13 drops into the notch 26, but is released therefrom by continued winding. It is usual, in practice, to rotate the barrel 4 and drum *o* four complete revolutions and then allow the lug 25 to remain in the notch 26 which holds the spring 13 under tension. Upon releasing the upward pull on the rope *p* the surface 31 of the ratchets 8 engages the part 32 of the pawl 9 unlocking the pawl 9 and allowing the drum *o* to rotate freely as before.

Having thus described my invention, what I claim and desire to secure by Letters Patent of the United States, is:—

1. In a retrieving trolley-catcher, a retrieving winding-drum, an actuating spring therefor, and an automatic locking device for said drum to render the latter inoperative when disconnected from its support.
2. In a device of the class described, a winding-drum, means for locking the same to a support, said means including a sliding bolt engaging the support whereby the winding-drum is automatically released when in locked position.
3. In a device of the class described, in combination, a drum, a support therefor, automatically operating means to render the drum inoperative when detached from its support.
4. In a trolley-catcher and retriever, a holding-ring

adapted to be secured to the car, a main casting, a stud or bolt secured at one end to the casting, a drum, a spring, one end being secured to the casting and the other to the drum, a spring-barrel rotatably mounted upon said bolt or stud, a spring within said barrel having one end secured in a slot in the end of the stud and its opposite end to the barrel, a series of ratchets in the interior of said drum, a pawl on the spring-barrel, said ratchets normally engaging the pawl so that the free end of the pawl runs clear of the ratchets, but upon a sudden movement of the drum the spring-barrel and drum are locked together, and means for releasing the pawl from the drum.

5. In a device of the class described, a holding-ring, a casting having means for locking the same to the holding-ring, a stud or bolt rigidly secured at one end to the casting and having a slot in the outer end of the same, a drum, a spring one end of which is attached to the casting and its opposite end to the drum, a barrel, a spring within said barrel, one end of which is inserted in the slot of the stud and the opposite end is attached to the outer part of the barrel, a pawl pivotally mounted between the sides of the barrel and having an upturned end that normally projects above the periphery of the barrel while its other end is flush with the periphery of the same, a spring for holding the upturned end of said pawl normally above the periphery of the barrel, and means on the drum for rotating said pawl for locking the drum and barrel together.

6. In a device of the class described, a holding-ring, a casting having means for locking the same to the holding-ring, a stud or bolt rigidly secured at one end to the casting and having a slot in the outer end of the same, a drum, a spring one end of which is attached to the casting and its opposite end to the drum, a barrel, a spring within said barrel, one end of which is inserted in the slot of the stud and the opposite end is attached to the outer part of the barrel, a pawl pivotally mounted between the sides of the barrel and having an upturned end that normally projects above the periphery of the barrel while its other end is flush with the periphery of the same, a spring for holding the upturned end of said pawl normally above the periphery of the barrel, and means on the drum for rotating said pawl for locking the drum and barrel together said means consisting of a series of ratchets on the interior of the winding-drum, and means for releasing the pawl and drum.

7. In a trolley-catcher and retriever, a holding-ring, a casting, a stud secured to said casting and having a slot in its other end, a drum rotatably mounted in said stud, a spring connected between the casting and drum, a series of ratchets on the interior of the drum, a locking pawl adapted to engage said ratchets, the length of the pawl being less than the distance between two successive ratchets, a barrel located on the outer end of said stud, a spring connected between the barrel and stud, a trigger pivotally secured to the barrel, a spring-retained piece pivotally secured to the trigger and arranged with one end over the said locking pawl, and means on the locking pawl for holding the same in locking engagement with the ratchets of the drum until released by the locking-pawl.

8. In a device of the class described, a drum, a series of ratchets thereon, a barrel, a pawl pivotally mounted in an opening between the sides thereof and substantially S-shape in form, one end of the pawl being normally above the periphery of the barrel and in the path of the movement of the ratchets on the drum, the free end of the pawl being arranged so as to lock the winding-drum and barrel together when one end of the pawl receives an abnormal blow thereon.

9. In a device of the class described, means for securing the same to a fixed support, a stud for rotatably supporting a drum and a barrel, said drum and barrel, a spring located between the drum and a sleeve on said stud, a spring located in the barrel, one end being secured to the stud and the opposite end to the outer part of the same, the last mentioned spring being of greater strength than the first mentioned spring, a washer having a notch in the periphery of the same and on the outer end of the stud, and means for preventing rotation of the washer, a tri-

pivotally secured to the barrel and normally engaging
 the notch in the washer, a spring-retained piece pivotally
 secured to the trigger and having a lip at right angles
 thereto, a notch cut in one of the sides of the barrel, a
 5 pawl pivotally mounted between the sides of the barrel
 and having a lug thereon and adapted to enter the notch
 in the side of the plate of the barrel, a spring located be-
 tween a fixed pin on the barrel and the lug of the locking-
 10 pawl, said locking-pawl being substantially S-shape in
 form and normally held so that one end thereof is above
 the periphery of the barrel while its opposite end is
 below the periphery of the same, a series of ratchets in
 the interior of the drum and normally delivering a light
 15 blow to one end of the locking-pawl, said spring on the
 spring-barrel permitting the locking-pawl to become en-

gaged by the ratchets of the winding-drum when an
 abnormal blow is delivered to the same, said locking-pawl
 under the influence of the spring in the spring-barrel ro-
 tating the winding-drum in an opposite direction until
 the pawl on the outer face of the spring-barrel reengages 20
 the notch in the holding-washer and the lip on the spring-
 retained piece permitting the lug on the locking-pawl to
 pass by the same, the near side of said ratchet engaging
 the locking pawl whereby the same is disengaged from
 the ratchets of the winding-drum as described.

JULIAN L. PERKINS.

Witnesses:

WM. H. CHAPIN,
 K. I. CLEMONS.