



AU9344258

(12) PATENT ABRIDGMENT (11) Document No. AU-B-44258/93
(19) AUSTRALIAN PATENT OFFICE (10) Acceptance No. 663395

- (54) Title
IMPROVED JOURNAL BEARING WITH BEARING-SHAFT CLEARANCE ZONE
- International Patent Classification(s)
(51)⁵ **F16C 033/04**
- (21) Application No. : **44258/93** (22) Application Date : **28.07.93**
- (30) Priority Data
- (31) Number (32) Date (33) Country
921860 29.07.92 US UNITED STATES OF AMERICA
- (43) Publication Date : **03.02.94**
- (44) Publication Date of Accepted Application : **05.10.95**
- (71) Applicant(s)
HARNISCHFEGER CORPORATION
- (72) Inventor(s)
HARVEY J. KALLENBERGER
- (74) Attorney or Agent
SPRUSON & FERGUSON , GPO Box 3898, SYDNEY NSW 2001
- (56) Prior Art Documents
US 5161748
GB 1539420
GB 1380947
- (57) Claim

1. A mechanical drive train comprising:
a bushing-type plain journal bearing with a bearing end;
a housing radially supporting the bearing to a reference plane; and
a shaft extending through the bearing beyond the reference plane at least to the bearing end, said drive train further comprising:
a contoured surface formed on an inner surface of the bearing and being substantially bounded by the end of the bearing and the reference plane to define a clearance zone between the shaft and the bearing;
whereby the shaft is substantially prevented from contacting the bearing between the bearing end and the reference plane and fatigue breaking of the bearing is substantially reduced.

663395

S & F Ref: 240726

AUSTRALIA
PATENTS ACT 1990

COMPLETE SPECIFICATION

FOR A STANDARD PATENT

ORIGINAL

Name and Address
of Applicant: Harnischfeger Corporation
13400 Bishops Lane
Brookfield Wisconsin 53005
UNITED STATES OF AMERICA

Actual Inventor(s): Harvey J. Kallenberger

Address for Service: Spruson & Ferguson, Patent Attorneys
Level 33 St Martins Tower, 31 Market Street
Sydney, New South Wales, 2000, Australia

Invention Title: Improved Journal Bearing with Bearing-Shaft Clearance
Zone

The following statement is a full description of this invention, including the best method of performing it known to me/us:-

Field of the Invention

This invention relates generally to multi-part mechanical devices and, more particularly, to mechanical drive trains for power transmission.

Background of the Invention

5 Mechanical drive trains use gears, shafts, gearboxes, pulleys and the like to transmit power from a "prime mover", e.g., an electric motor or internal combustion engine, to an end-use function. All such drive trains use a number of bearings and, often, such bearings are of differing types. For example, the output shaft of an electric motor, considered a high speed shaft, is supported on ball, roller or some other type of
10 so-called hydrodynamic bearing. Such bearings are so named because of the way their surfaces are "self-lubricated" as they roll.

At other locations, such drive trains may use what are called bushing-type or plain journal bearings. Journal bearings do not use rolling balls or cylinders. Rather, they are simply cylindrical tubes, with or without flanged ends, and are often made of
15 brass or bronze. Journal bearings, said to be "boundary lubricated", are used in drive train applications where relative rotational speed is quite low and where the bearing and shaft through the bearing are subjected to high-impact, tipping or bending loads or a combination of such loads.

Journal bearings (which are fitted over a shaft) are often fitted into a
20 surrounding housing. To put it another way, the bearing is interposed between a shaft and a housing, the latter "reinforcing" and supporting the bearing against loads imposed on it by the shaft. However, the housing may not span the entirety of the distance between the bearing ends. As a consequence, a portion of the bearing near one or both ends is radially unsupported.



An unsupported portion is therefore exposed to shaft-imposed forces which may repeatedly deform and "fatigue" the end of the bearing. This can and does cause the bearing to eventually fracture around a portion of all of the bearing circumference. Machine downtime and a (usually) expensive repair follow.

5 The invention seeks to resolve problems relating to fatigue breaking of a radially-unsupported end of a bushing-type plain journal bearing. Such breaking can result when the shaft extending through the bearing repeatedly deflects and bends radially outward against the end, thereby "fatigues" the bearing and, finally, breaks off a ring-like portion of the end.

10 Known journal bearings are made with a slight "corner break" or radius at the junction of an end face and the internal bore. Such a radius is provided to prevent fragmentation of tiny particles from what would otherwise be a rather sharp edge. As will become apparent, such a radius is unrelated to the invention.

15 An improved mechanical drive train having a journal bearing with a contoured surface to define a clearance zone between the shaft and the bearing would help prevent bearing fatigue breaking, excessive localized heating and wear and the formation of wear particles (all of which reduce bearing life), and, therefore, would be an important advance in the art.

20 This application refers to shafts which "deflect" or which are "deflected". As used herein, such terms refer to shafts which are bent, which are tipped or which, by a combination of bending and tipping forces, are made other than straight and/or other than axially aligned with a bearing

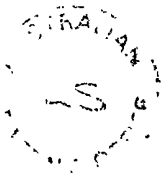

Object of the Invention

It is an object of the invention to provide an improved mechanical drive train overcoming some of the problems and shortcomings of the prior art.

Summary of the Invention

5 The present invention in one broad form provides a mechanical drive train comprising:

 a bushing-type plain journal bearing with a bearing end;

 a housing radially supporting the bearing to a reference plane; and

 a shaft extending through the bearing beyond the reference plane at least to the
10 bearing end, said drive train further comprising:

 a contoured surface formed on an inner surface of the bearing and being substantially bounded by the end of the bearing and the reference plane to define a clearance zone between the shaft and the bearing;

 whereby the shaft is substantially prevented from contacting the bearing
15 between the bearing end and the reference plane and fatigue breaking of the bearing is substantially reduced.

 Parts of this summary use geometric terms which may be better visualized with reference to a drawing. The detailed description (set out below) and the drawing will, if carefully analyzed, clarify such terms.

In a preferred embodiment, the contoured or "relief" surface extends between the end and the reference plane. The "contour" of the surface can take any of several shapes, each of which is described with reference to a "viewing plane" and to the shaft axis of rotation which is coincident with such viewing plane. In one version, that
5 portion of the surface coincident with the viewing plane defines a curved line. In another version, that portion of the surface coincident with the viewing plane defines a compound curved line and in yet another version, that portion of the surface coincident with the viewing plane defines a straight line.

And there are other contour shape possibilities. For example, that portion of
10 the surface coincident with the viewing plane may define a line which is a "composite", i.e., which has plural segments selected from a group of segments including a curved segment, a compound curved segment and a straight segment.

When the shaft is undeflected, the clearance zone comprises a generally V-shaped annular space between the surface and the shaft. However, as the shaft deflects,
15 a portion of the space may "close up" or even substantially disappear in that area where the shaft approaches or comes into rather light contact with the radially-unsupported end.

Description of the Drawings

Figure 1 is a cross-sectional view, with parts broken away, of the inventive
20 journal bearing shown in conjunction with mechanical drive train components.

Figure 2 is a view, partly in cross-section and with parts broken away, of the inventive journal bearing shown in conjunction with an exemplary housing and shaft supporting a gear.

Figure 3 is an isometric view of a portion of the exemplary structure of Figure 2.

Figures 4, 5 and 6 are cross-sectional views, with parts broken away, showing exemplary contoured surfaces on a bearing.

Figure 7 is a view, partly in cross-section and with parts broken away, showing how the new journal bearing avoids bearing breakage in a drive train having a bent shaft.

Figure 8 is a view, partly in cross-section and with parts broken away, showing how the new journal bearing avoids bearing breakage in a drive train having a tipped or canted shaft.

Figure 9 is an isometric view of a prior art, unimproved plain journal bearing.

Figure 10 is a view, partly in cross-section, taken along the viewing plane 10-10 of Figure 9, and also includes a shaft through the bearing and a housing supporting the bearing along a portion of its length. The viewing plane is coincident with the central long axis of the bearing of Figure 9.

Referring first to Figures 9 and 10, the inventive bearing 10 will be better appreciated by first having an understanding of aspects of a conventional bushing-type journal bearing 110 and how such a bearing 110 is typically mounted. Such a bearing 110 has a tubular body 111, the wall of which is of generally uniform thickness. The bearing 110 may consist only of such a body 111 or may also include a radially outwardly extending flange 113 at one or both ends. An edge 115 is formed at the junction of an end face 117 and the internal bore 119 and, typically, such edge 115 is formed to a slight radius as shown in the region 121. Such otherwise knife-like edges 115 are referred to in the industry as thereby being "broken" and a common notation on manufacturing drawings is to "break the

edge" or "break corner" to a particular small radius or chamfer.

It is apparent from Figure 10 that the radius in the region 121 does not extend to that portion of the bearing 110 which is supported by, say, a bearing housing 11. For that reason, a deflected shaft 13 may create areas of unusually high stress, often called "stress risers" because of the shape of a graphic curve representing stress. As a result, the bearing 110 "fatigues" and fractures 123 often result. The inventive bearing 10 solves this problem in a unique and imaginative way.

Referring to Figures 1-3 from which certain cross-hatching has been omitted for clarity, the improved plain journal bearing 10 is shown in conjunction with components of a mechanical drive train. Such components include a housing 11 wall radially supporting a bearing 10 along a portion of the bearing length. In Figures 1 and 2, two bearings 10 and two housings 11 are shown in support of a gear 12, such gear 12 being exemplary of any component supported on, driven by or driving a shaft. The invention will be described primarily with respect to only one bearing 10 and housing 11.

The side face 15 of the housing 11 is coincident with and defines a reference plane 17 which extends into and out of the drawing sheet and is perpendicular to such sheet. In Figure 1, the viewer sees the edge of the reference plane 17. A shaft 13 extends through the bearing 10 beyond the reference plane 17 at least to the bearing end and, typically, beyond such end.

A contoured surface 19 (somewhat resembling a chamfer) is formed circumferentially around the end 21 of the bearing 10 and preferably extends between the end 21 and the reference plane 17. As described in greater detail below, the surface 19 and the shaft 13 define a

generally V-shaped annular space 23 when the shaft 13 is undeflected. This space 23 is referred to as a clearance zone.

5 It is helpful to describe aspects of the contoured surface 19 with respect to a viewing plane 25. Considering Figure 2, the shaft 13 has an axis of rotation 27 coincident with a viewing plane 25. Such viewing plane 25 extends perpendicularly into and out of the drawing sheet in Figure 2 and the viewer sees the
10 edge of such plane 25. In Figure 1, the viewing plane 25 and the axis 27 are coincident and the plane 25 is coincident with the drawing sheet.

It should be appreciated that the more common arrangement is to mount the bearing 10 with its
15 flange toward the supported component as shown in Figure 1. In the arrangement of Figure 2, the flanges are away from the gear 12 to show an alternate arrangement.

In the views of Figures 1, 2 and 4, that portion of the contoured surface 19 which is coincident
20 with the viewing plane 25 defines a curved line 29. In a way familiar to persons in the mechanical and geometric arts, the surface is "generated" by rotating the line 29 about the axis 27.

However, such surface 19 can have any of a
25 variety of shapes and still be effective for its purpose. For example, that portion of the surface 19 coincident with the viewing plane 17 as shown in Figure 5 defines a compound curved line 31, i.e., a line 31 having segments formed using two different radii. And it
30 is to be appreciated that the compound curved line 31 could be formed using a constantly changing radius, i.e., such as formed as a segment of a parabola. That portion of the surface 19 coincident with the viewing plane 17 as shown in Figure 6 defines a straight line
35 33. Other contoured surfaces 19 can be "generated" by selecting from a group of segments including a curved

segment (Figure 2), a compound curved segment (Figure 5) and a straight segment (Figure 6).

5 Figures 7 and 8 show tube-like journal bearings 10 devoid of flanges 113. As shown in Figure 7 and because of the assumed nature of the application in which the drive train is used, the shaft 13 may be subjected to bending loads as represented by the downward force vector near the middle of the shaft 13 and the upward force vectors 37 at the shaft ends. In
10 Figure 8, the shaft 13 is shown to be subjected to what is called a "force couple", i.e., a pair of non-coincident but generally parallel forces 39 acting in opposite directions. Such forces 39 (or even a single force 39) tip but do not necessarily bend the shaft 13.
15 And, of course, the shaft 13 may be subjected to a combination of such forces.

 Using the improved bearing 10, it is now apparent that even though the shaft 13 may be bent, tipped or otherwise deflected, the shaft 13 is
20 substantially prevented from contacting the bearing 10 because of the contoured surface 19 and the resulting space 23. Fatigue fractures 123 or breaking (such as are illustrated in Figure 10) are substantially avoided.

 This is not to say that in a severe instance
25 of shaft deflection, the shaft 13 will never contact the surface 19. However, such incidents of shaft-surface contact are avoided in all but the most extreme cases.

 While the principles of the invention have been shown and described in connection with specific
30 embodiments, it should be clearly understood that such descriptions and embodiments are exemplary and not intended to limit the invention.

The claims defining the invention are as follows:

1. A mechanical drive train comprising:
a bushing-type plain journal bearing with a bearing end;
a housing radially supporting the bearing to a reference plane; and
5 a shaft extending through the bearing beyond the reference plane at least to the bearing end, said drive train further comprising:
a contoured surface formed on an inner surface of the bearing and being substantially bounded by the end of the bearing and the reference plane to define a clearance zone between the shaft and the bearing;
10 whereby the shaft is substantially prevented from contacting the bearing between the bearing end and the reference plane and fatigue breaking of the bearing is substantially reduced.
2. The mechanical drive train of claim 1, wherein the shaft has an axis of rotation coincident with a viewing plane and that portion of the surface coincident with
15 the viewing plane defines a curved line.
3. The mechanical drive train of claim 1, wherein the shaft has an axis of rotation coincident with a viewing plane and that portion of the surface coincident with the viewing plane defines a compound curved line.
4. The mechanical drive train of claim 1, wherein the shaft has an axis of
20 rotation coincident with a viewing plane and that portion of the surface coincident with the viewing plane defines a straight line.
5. The mechanical drive train of claim 1, wherein the shaft has an axis of rotation coincident with a viewing plane and that portion of the surface coincident with the viewing plane defines a line having plural segments selected from a group of
25 segments including a curved segment, a compound curved segment and a straight segment.
6. The mechanical drive train of claim 1, wherein the clearance zone comprises a generally V-shaped annular space between the surface and the shaft when the shaft is undeflected.
- 30 7. A mechanical drive train substantially as hereinbefore described with reference to the accompanying drawings.

DATED this Second Day of August 1995

Harnischfeger Corporation
Patent Attorneys for the Applicant
SPRUSON & FERGUSON



Improved Journal Bearing
with Bearing-Shaft Clearance Zone

ABSTRACT

The invention is an improvement in a mechanical drive train having a bushing-type plain journal bearing (10), a housing (11) radially supporting the bearing (10) to a reference plane (17), and a shaft (13) extending through the bearing (10) beyond the reference plane (17). That portion of the bearing (10) between the reference plane (17) and a bearing end is unsupported by the housing (11) and therefore subject to fatigue breakage as the shaft (13) repeatedly deflects or tips. The improvement comprises a contoured surface (19) formed on an end of the bearing (10) to define a clearance zone (23). When the shaft (13) deflects or tips under load or for other reasons, the shaft (13) is prevented from contacting the bearing (10) along the zone (23). Fatigue breaking of the bearing (10) is thereby substantially reduced.

Fig 1

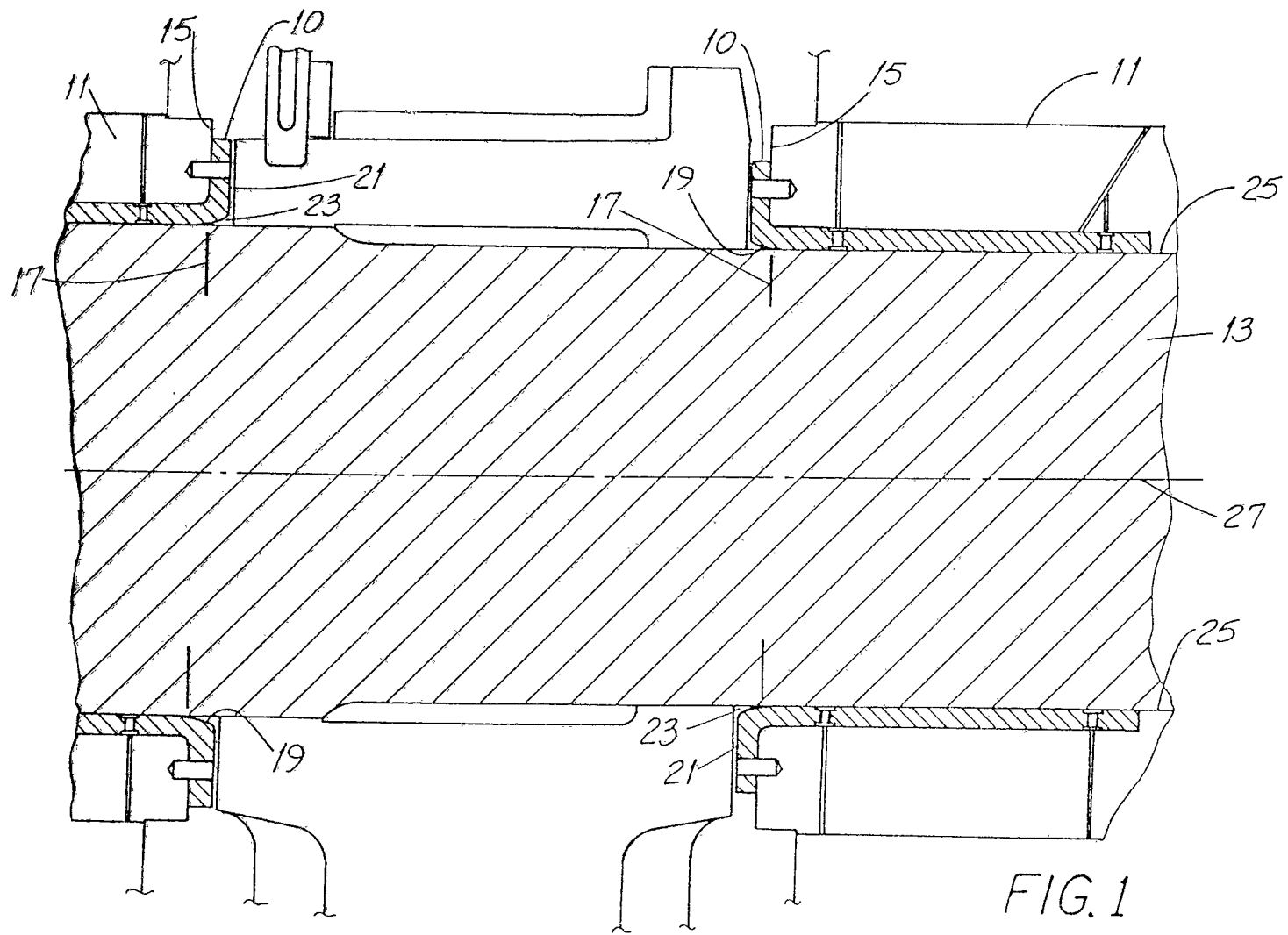

1/5

44-258/93

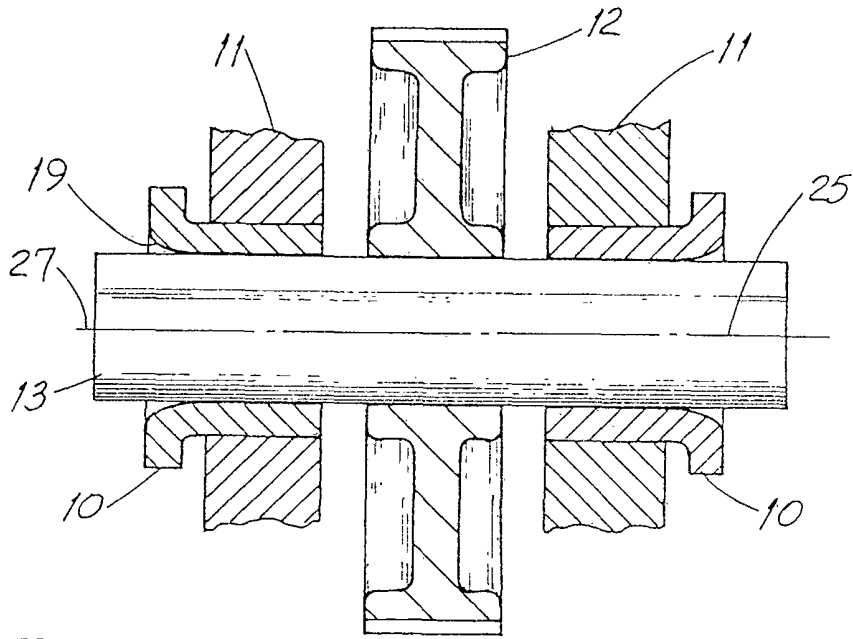

FIG. 2

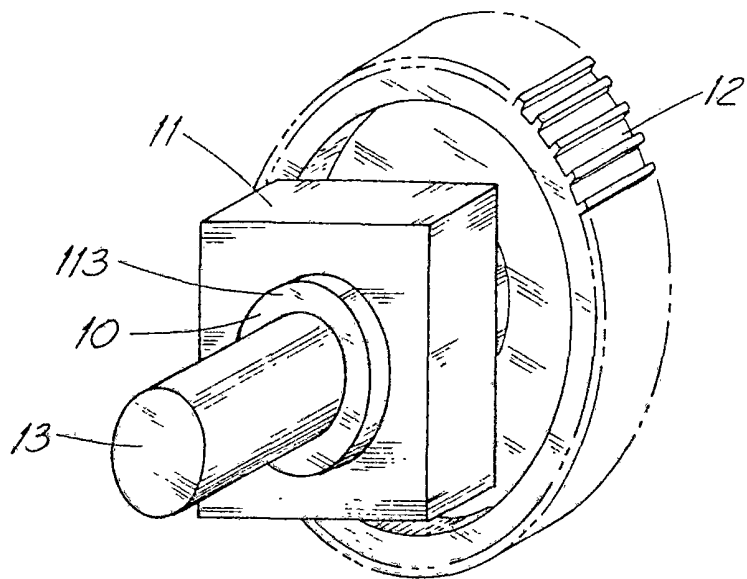

FIG. 3

3/5

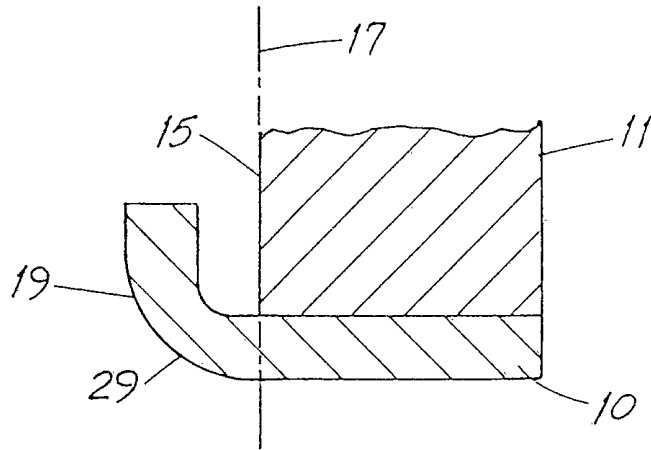

FIG. 4

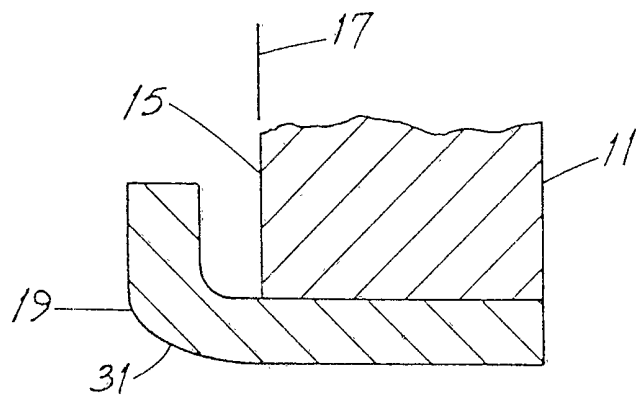

FIG. 5

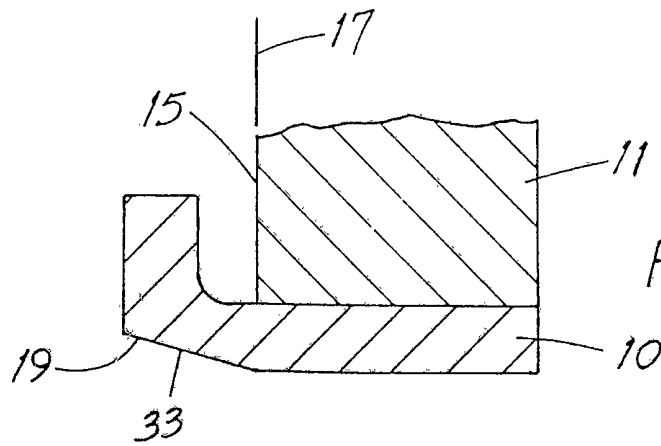

FIG. 6

4/5

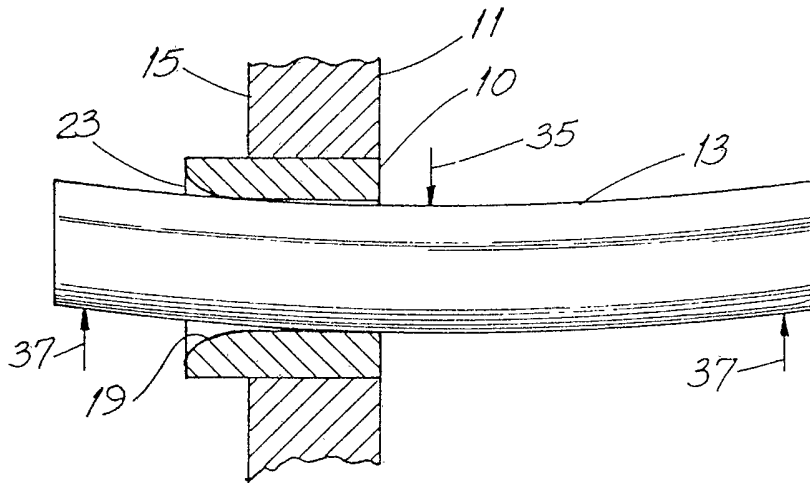

FIG. 7

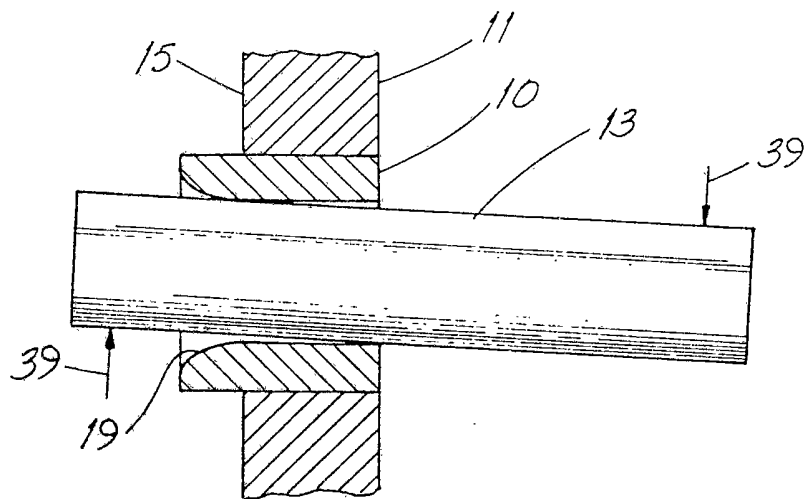

FIG. 8

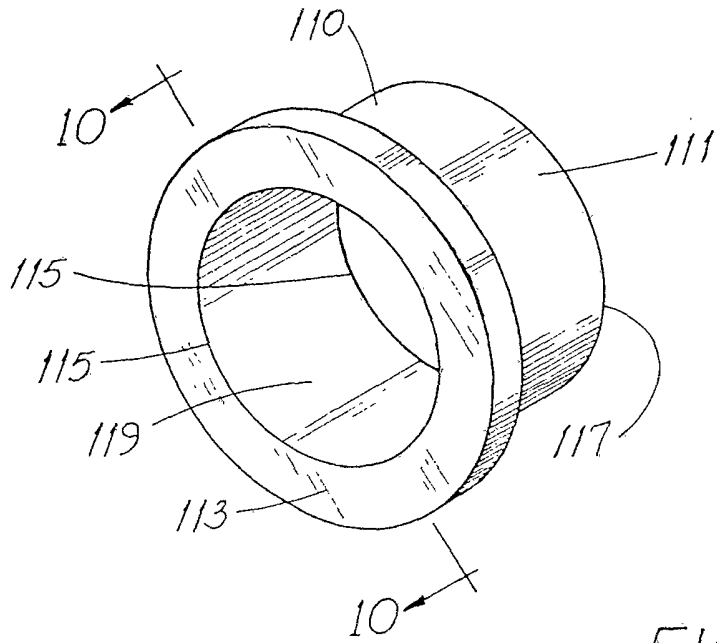

FIG. 9
PRIOR ART

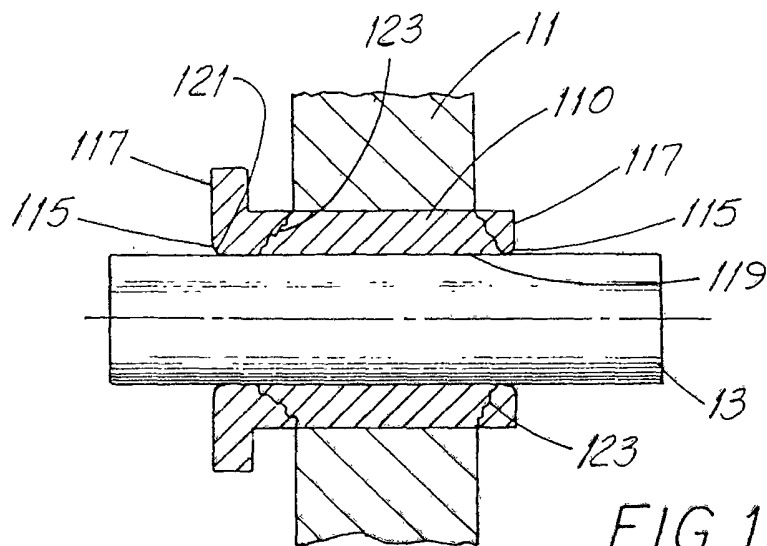

FIG. 10
PRIOR ART