

(19)



Europäisches Patentamt
European Patent Office
Office européen des brevets



(11)

EP 0 767 750 B1

(12)

EUROPEAN PATENT SPECIFICATION

(45) Date of publication and mention of the grant of the patent:

16.08.2000 Bulletin 2000/33

(21) Application number: **95904041.1**

(22) Date of filing: **02.01.1995**

(51) Int. Cl.⁷: **B63B 21/00**, B63B 21/04

(86) International application number:
PCT/NL95/00002

(87) International publication number:
WO 95/18038 (06.07.1995 Gazette 1995/29)

(54) A METHOD OF MANIPULATING A CONNECTING ELEMENT IN SHIPPING

VERFAHREN ZUM MANIPULIEREN EINES VERBINDUNGSELEMENTES IN DER SCHIFFFAHRT

PROCEDE DE MANIPULATION D'UN ELEMENT DE RACCORDEMENT POUR LA NAVIGATION

(84) Designated Contracting States:
DE DK ES FR GB NL SE

(30) Priority: **31.12.1993 NL 9302289**

(43) Date of publication of application:
16.04.1997 Bulletin 1997/16

(73) Proprietor: **Aarts, Sven Olaf**
1018 AK Amsterdam (NL)

(72) Inventor: **Aarts, Sven Olaf**
1018 AK Amsterdam (NL)

(74) Representative:
Smulders, Theodorus A.H.J., Ir. et al
Vereenigde
Postbus 87930
2508 DH Den Haag (NL)

(56) References cited:
EP-A- 0 046 547 **WO-A-91/14615**
DE-A- 3 049 235 **GB-A- 1 395 886**
US-A- 4 729 332 **US-A- 4 932 700**

- **PATENT ABSTRACTS OF JAPAN vol. 7, no. 254 (M-255) (1399) 11 November 1983 & JP,A,58 136 585 (HITACHI ZOSEN) 13 August 1983**

EP 0 767 750 B1

Note: Within nine months from the publication of the mention of the grant of the European patent, any person may give notice to the European Patent Office of opposition to the European patent granted. Notice of opposition shall be filed in a written reasoned statement. It shall not be deemed to have been filed until the opposition fee has been paid. (Art. 99(1) European Patent Convention).

Description

[0001] This invention relates to a method according to the preamble of claim 1. Such a method is known from US-4,729,332.

[0002] In shipping, it is common practice to shift or to support ships, offshore installation and such objects located on or in the water by means of one or more tugboats during maneuvers, especially in the vicinity of mooring installations, such as ports, jetties and quays. For this purpose a connecting element is arranged between the tug and the tow, and is fastened on both sides. In a comparable manner, however, ships and the like are fastened to quays and such mooring installations, the tow being moved by means of a number of tugboats to near the mooring installation and being attached thereto.

[0003] Conventional connecting elements are cables and chains, and optionally bars, one end of which being firmly attached to the tug, and the other end being provided with e.g. a loop or hook, which can be fastened around a bollard, a cleat, a towing hook or a towing eye and the like. Before towing, a tug is maneuvered to near the tow, or the tow to near the tug, after which, in general, the free end of the connecting element is transferred from the tug to the tow. For this purpose various methods are used.

[0004] Thus, the free end of the connecting element can be attached to a thin rope, the so-called heaving line, after which the free end of the heaving line is thrown over or shot at the tow by means of a rocket or such projectile, or is sailed to the tow by means of a small boat and brought on board via a ladder. By hauling in the heaving line, the usually heavy connecting element is then pulled towards the tow, optionally by means of one or more thicker intermediate cables, until its free end is brought on board the tow. This free end is then secured on board the tow by a number of people, e.g. by lifting a loop formed at the fastening element over a bollard by manual effort or by passing it through an eye and fastening it thereto.

[0005] An important drawback of throwing over, and in particular of using a rocket or such projectile, is the extreme susceptibility to weather conditions. In particular during a storm it will be practically impossible to get the end of the heaving line on board the tow. Moreover, the tug must then be located on the side of the tow whence the wind comes, which is not always the side to which the connecting element is to be fastened, so that the tug must then be maneuvered to another side of the tow. Moreover, the rocket itself and the heaving line involve a risk to members of the crew and bystanders, both on the tug and on the tow.

[0006] When using a boat for transferring the end of the connecting element, someone must sail between the tug and the tow and must often climb up a ladder against the tow with the line on him. Here, too, the line will often be brought on board on the other side of the

ship than the side on which the connecting element is to be fastened. Moreover, sailing across and climbing on board the tow involve a risk to people, in particular in heavy weather.

5 **[0007]** Both methods described are labor-intensive and require, both on the tow and on the tug, operations to be carried out by people, which operations are therefore time-consuming and expensive and are highly influenced by, inter alia, weather and other labor conditions.

10 People may then run the risk of getting wounded during sailing across and unfastening or fastening the connecting element, and the method of making the connection strongly depends on the skill of those carrying out the operations.

15 **[0008]** When breaking the connection, the end of the connecting element fastened to the tow is thrown back into the water, while in cases of emergency the connecting element is often cut, after which the connecting element is drawn on board the tug, which involves the risk of the connecting element getting entangled with the propeller.

20 **[0009]** Further, methods are known for arranging connecting elements between a tug and a tow, using, e.g., magnets or suction cups to be placed on the skin of the tow, which magnets or suction cups are connected with a cable and the like. These connecting elements must remain energized continuously during the fastening period, because otherwise the connection is broken so that these connecting methods are not suitable for a prolonged attachment. Moreover, in particular the use of an (electro)magnet has the drawback that it causes large electric and magnetic fields. Since ships are in general earthed to the body, this may cause great damage to the electric installations of the tow. Moreover, the use of electricity is very dangerous in the vicinity of, in particular, tankers.

35 **[0010]** U.S. 4,729,332 describes an apparatus and a method of mooring a ship along a quay or the like, comprising a spherical coupling member fastened to a first cable and capable of being caught behind a bollard on a ship, which coupling member can be positioned behind the bollard by means of a second cable fastened to a crane. Positioning of the coupling member is only possible from a top side and is chiefly accomplished under the action of gravity. These coupling apparatus and method are not useful for coupling a tugboat to an object to be towed. When using such an apparatus and method, especially in heavy weather, the coupling member will be going to swing relative to the bollard, while, moreover, the bollard will move up and down and to and fro relative to the crane and, consequently, relative to the coupling member. Certainly when the crane is used on a floating quay or boat, the coupling member will not be fastened behind the bollard without the aid of people aboard the object to be towed. But the use of manpower aboard the object to be towed should, for the above reasons, be prevented. Moreover, a crane from the prior art assembly should be very high in order to

reach from a relatively low tug to far above a deck of a relatively high tow. This means that in case of a relatively slight movement of the tug about one of its axes the crane would perform enormous movements at its free end. With the manipulator according to the invention this is simply prevented or at least becomes compensable.

[0011] The object of the invention is to provide a method of the type described in the opening paragraph, in which the drawbacks of the known methods are avoided and the advantages thereof are maintained. For this purpose the method according to the invention is characterized by the characterizing part of claim 1.

[0012] In the method according to the invention the connecting element is gripped directly, that is in direct contact, and picked up from the tow with a manipulator and is then transferred by means of the manipulator from the tug to the tow, or from the tow to the tug, without the help of people in a direct sense, i.e. for operations other than control. This prevents the occurrence of danger to people on the tow or the tug, or to bystanders, during picking up and moving the connecting element between the tow and the tug. A further advantage of the method according to the invention is that a connection between the tow and the tug can be made with fewer people so that a clear economic advantage is obtained

[0013] Since the coupling element, after fastening to the object to be towed, can be released by the manipulator, the distance between the tug and the object to be towed can be enlarged or reduced as required. At least partial retraction of the manipulator ensures that the connecting element has sufficient freedom of movement and is not hindered by the manipulator, nor by, e.g., personnel. Accordingly, the manipulator cannot be damaged, though it is capable of following and, if required, controlling movements of the connecting element.

[0014] Moreover, this method has the advantage that the manipulator can bring the free end of the connecting element picked up to the desired position in a very direct way, irrespective of the weather. This means that even in heavy seas and strong winds the connection between the tow and the tug can be made and broken with no danger to bystanders, also against the direction of the wind. This has the further advantage that when breaking the connection the connecting element does not fall loosely into the water, which is of great importance, in particular near the ship's propellers of a tow and a tug. In actual fact, when the free end of the connecting element falls into the water near a ship's propeller, there is a great risk of the connecting element getting entangled therewith, as a result of which great damage may be caused to the ship's propeller and, moreover, the ship in question may become unmanageable.

[0015] When shooting, throwing or sailing across and fastening or unfastening the connecting element for making or breaking a connection between a tow and a

tug someone must be or go on board the tow. Apart from the above dangers with respect to sailing across. This is undesirable in specific cases, in particular when making and breaking connections with shipwrecks and other potentially dangerous objects, such as burning ships. Consequently, in a preferred embodiment a method according to the invention is characterized by claim 2.

[0016] Thus, a connection can be made and broken by means of the manipulator, so that the whole method can be carried out from, e.g., the tug, with no necessity of manning the tow, but even so, the connecting element is safely moved, fastened and unfastened. Moreover, this method gives the advantage that the connecting element need not be gripped by man-power, so that the risk of accidents is minimized, the more so as the connecting element need not get loose from the manipulator at any moment.

[0017] In further elaboration a method according to the present invention is characterized by the features of claim 3. This enables a safe and good control of the manipulator whatever the circumstances.

[0018] In a further elaboration the method according to the invention is characterized by the features of claim 4.

[0019] By fastening the fastening element out of reach of people on a deck of the tow, the risk of these people getting wounded is easily reduced. With the manipulator such a position can be reached indeed, so that, unlike in the known methods, such an attachment is quite possible with the method according to the invention. Moreover, the fastening element can be arranged in a very favorable position, in particular near the waterline of the tow. In general, the tow will rise above the surface of the water much more than the tug. In the known methods of fastening the connecting element this means that the connecting element slopes steeply, which results in a very unfavorable load. By fastening the fastening element near the waterline, or at least clearly lower than the deck of the tow, and preferably at about the same level as the tug, the connecting element may slope less steeply or even extend in a nearly horizontal direction so as to obtain an optimum load characteristic of the tow, the tug, the connecting element, and the fastening elements.

[0020] When mooring a tow to a mooring installation, such as a quay, it is common practice to pull or push the tow by a number of tugboats towards the quay, which tugboats are to move the tow to the quay, and to steer it away from the quay as well. This means that either a large number of tugboats must be used or the tugboats must always sail from one side of the tow to the other. Moreover, the direction of pulling of the tugboats becomes increasingly unfavorable as the tow comes closer to the quay, because then the tugboats can no longer sail between the quay and the tow and must therefore pull diagonally in front of or behind the tow. It is therefore common practice to bring a tow to the

mooring installation in a number of steps, while pulling alternately one and the other end a little closer to the mooring installation. In particular these maneuvers with the tow and the tugboats render the mooring procedure time-consuming and complicated.

[0021] In order to avoid these problems, in a further elaboration of the method according to the invention a manipulator is placed on a mooring installation in a suitable position and the connecting element is coupled to the tow, after which by means of the connecting element provided by the manipulator the tow is pulled closer to the mooring installation and then secured thereto. Since the manipulator is placed on the mooring installation, the tow can be pulled continuously in a favorable direction. For instance, when mooring a seagoing ship in the longitudinal direction of a quay, it can always be pulled at about right angles to the longitudinal direction, so that the ship can be pulled towards the mooring installation parallel thereto. On the side facing away from the mooring installation the ship may then be slowed down a little by tugboats, if necessary. Preferably, a number of manipulators is used simultaneously.

[0022] The invention further relates to an assembly according to the preamble of claim 7.

[0023] In towing, it is unsafe, time-consuming and labor-intensive and thus expensive to make and break connections between a tug and a tow. It is therefore an object of the invention to provide an assembly in accordance with the preamble of claim 7, avoiding these drawbacks. The assembly according to the invention is characterized by the features of the characterizing part of claim 7.

[0024] With an assembly according to the present invention a connection between a tug and a tow can be very accurately and economically established and/or broken without any danger for the material or people involved, uninfluenced of the weather conditions and differences in size of the tug and the tow.

[0025] In a preferred embodiment of the assembly according to the invention the manipulator and the gripper element are designed for such manipulation of the connecting element that a coupling between the connecting element and the tow can be made and broken without human intervention other than for controlling the manipulator.

[0026] With the assembly according to the invention a connection can be made and broken in a rapid and effective manner with the help of few people and within a short time. It is thus possible to work safely at relatively low cost.

[0027] In a further elaboration of the invention the manipulator is characterized by the features of claim 12. As a result, the manipulator can be brought to an optimum position relative to the tow and the tug, while, simultaneously, the overpressure protections prevent the manipulator from coming into such contact with the tug or the tow as to cause damage, e.g. as a result of an unexpected movement of the tug relative to the tow

owing to the motion of the sea.

[0028] The winch according to the invention is provided with a control mechanism and a coiling reel, the control mechanism comprising running rollers, and the connecting element extending, at least in use, from the coiling reel through the running rollers. The running wheels are provided with a pressing mechanism for exerting a frictional force via the running rollers on the connecting element, the pressing mechanism being adjustable in such a manner that, in use, the tension in the connecting element is independent of the quantity of connecting element wound on the coiling reel.

[0029] When using the winch according to the inventions a constant tension can be applied to the connecting element, which tension can be predetermined and optionally adapted during use, and which tension is independent of the length of the connecting element wound on the coiling reel. In other words, the tension in the connecting element is independent of the diameter of the coiling reel with the part of the connecting element wound thereon. Consequently, the pressing mechanism can be of simple design, since no compensation for the diameter of the coiling reel is necessary and, moreover, the coiling reel may be of less heavy construction, since the running rollers receive a relatively large part of the tension in the connecting element.

[0030] The coupling assembly according to the invention comprises at least a connecting element that can be connected at one side to a tug.

[0031] The coupling assembly according to the invention has the advantage that a coupling can be easily made therewith by inserting the male part connected to the connecting element in the female part, with no further operations being required to make the connection. Consequently, this coupling assembly is eminently suited for use in the assembly according to the invention, because by means of the manipulator the male part can be easily placed in the female part. In the composite condition the convex surface of the male part has the advantage that it can rotate to some degree within the recess in the female part, so that the connecting element can always extend mainly in a favorable direction of pulling. Thus, chafing of the connecting element along the tow is largely avoided.

[0032] In a further elaboration of the coupling assembly according to the invention in the assembly a connection made can be broken in an easy, rapid and safe way with no necessity of people coming close to the fastening element. In particular in case of calamities, the connection can be directly broken, e.g. from the tug or the bridge of the tow, thus preventing accidents, and moreover, preventing the necessity of the tow being slowed down or coming to a standstill. A connection made by means of, e.g., a coupling assembly according to the invention provided with a push-out cylinder can be broken at relative high speeds and whatever the circumstances, without causing danger to the safety of the tow or the tug, and moreover, such a connection can be

made at relative high speeds and whatever the circumstances.

[0033] In explanation of the invention a number of practical examples will be described with reference to the accompanying drawings in which

Fig. 1 shows, in diagrammatic side elevation, an assembly according to the invention;

Fig. 2 shows, in diagrammatic top plan view, an alternative embodiment of an assembly according to the invention;

Fig. 3 shows, in four successive steps, a method according to the invention in connection with the mooring of a ship along a mooring installation;

Fig. 4 shows, in diagrammatic partly cross-sectional side elevation, a manipulator and a winch according to the invention;

Fig. 5 shows, in front elevation, the female part of a coupling assembly according to the invention;

Fig. 6 shows, in cross-sectional top plan view along the line VI - VI in Fig. 5, a coupling assembly according to the invention, in assembled condition;

Fig. 7 shows, in cross-sectional side elevation, an alternative embodiment of a coupling assembly according to the invention, provided with a push-out piston; and

Fig. 8 shows a female part of a further alternative embodiment of a coupling assembly according to the invention.

[0034] Fig. 1 shows a ship 1 to be towed and a tugboat 2. The ship 1 is provided with a bollard 5 disposed near the bow 3 on a deck 4 thereof. The tugboat is equipped with a manipulator 6 and a connecting element 7 extending therefrom, e.g. a cable, a chain or a webbing. At the end remote from the tugboat 2 the connecting element 7 is provided with a loop 8 which can be thrown around the bollard 5 so as to make a firm connection between the ship 1 and the tugboat 2. Besides, there may also be used other cooperating coupling assemblies, optionally known per se, or a coupling assembly according to the invention, as will be described below in more detail.

[0035] The manipulator 6 is provided with a winch 9 and an articulated arm 10, which are placed together on a turntable 11, thus enabling rotation of the manipulator around an axis of rotation extending substantially at right angles to the deck 12 of the tugboat 2. In the embodiment shown in Fig. 1 the articulated arm 10 consists of six arm portions 13 a-f hinged together and is provided at the free end with a gripper 14. It will be clear that more or fewer arm portions are also possible. The connecting element 7 extends from the winch 9 along or through the arm portions 13 a-f of the articulated arm 10 beyond the gripper 14, in such a manner that at least the loop 8 reaches out of the manipulator 6. The manipulator can be controlled directly, e.g. from a control panel 15 near the manipulator 6, but is preferably

remote-controlled, e.g. radio-controlled from the pilot-house 16 of the tugboat 2 or from the ship 1, or even from a quay, from the water or from the air. Remote control of the manipulator has the advantage that a good survey of the various movements of the ship 1, the tugboat 2, the manipulator 6 and the connecting element 7 can be obtained without running the risk of accidents.

[0036] With the assembly shown in Fig. 1 a connection between the ship 1 and the tugboat 2 can be made as follows.

[0037] The ship 1 is sailed to near the tug 2 or, the other way round, the tug to near the ship, the articulated arm 10 being kept in a compact position. Then the articulated arm 10 is brought to an at least partially stretched position, as shown in Fig. 1, and the free end is moved upwards to locate the gripper 14 above the level of the deck 4 of the ship 1. The connecting element 7 is nearly completely wound on the winch 9, so that only the loop 8 extends out of the articulated arm 10 and is held by the gripper 14. The gripper 14 is then manipulated to move the loop 8 over and fasten it around the bollard 5. Thus, the connection is made without people on board the ship 1 or the tugboat 2 having touched the connecting element 7 in any manner whatever or without so much as having to approach it. This means that this method according to the invention minimizes the risk of accidents during making connections between a ship 1 and a tugboat 2, while, furthermore, the connection can be made rapidly and accurately with a minimum of people, e.g. also in the absence of people on board the ship.

[0038] When the connection has been made, the connecting element 7 is released by the gripper 14 and the possibilities of movement of the articulated arm 10 and the turntable 11 are released so that the connecting element 7 can be pulled and kept taut, only by means of the winch 9. The tugboat 2 can then even sail away from the ship 1 some distance, while it simultaneously pays out the connecting element 7. The manipulator 6 will easily follow the movements of the connecting element 7 so that the load of the manipulator 6 is confined to a minimum during towing of the ship and chafing of the connecting element 7 is largely prevented.

[0039] When the connection between the ship 1 and the tugboat 2 has to be broken, e.g. because the ship has been brought to its destination or because of calamities, a reverse method can be used. The articulated arm 10 is maneuvered to enable the gripper 14 to take hold of the loop 8 again. Then the loop 8 can be taken from the bollard 5 by means of the manipulator 6, and the connection is broken. The articulated arm 10 is then retired, and the tugboat 2 can recede from the ship 1. Since the loop 8 is always controlled by the manipulator 6 before, during and after making and breaking the connection, the connecting element is prevented from being loose in the water at any moment, thus avoiding that the connecting element can get entangled with a propeller of the ship 1 or the tugboat 2, or can otherwise

hinder the movements thereof. Even when the connecting element must unexpectedly be cut in case of a calamity, it can be easily prevented from falling loose into the water. Moreover, the connecting element is thus prevented from becoming entangled.

[0040] During the making or breaking of the connection the two ships need not be brought to a standstill. Even at relatively high speeds (e.g. 12 knots) the connection can be safely and rapidly made or broken by means of the manipulator 6. This has the important advantage that little time and energy are lost and that, moreover, the risk of accidents is minimized.

[0041] The figure shows embodiments of the manipulator in which the connecting element 7 extends through or along the manipulator 6 and is wound on or unwound from a winch 9 connected with the manipulator. However, it is possible by means of the manipulator to pick up a connecting element which lies free on the deck of a tugboat or on a deck of a ship. It is even possible to pick up such a connecting element from a mooring installation, e.g. a quay. The connecting element is simply picked up by means of the gripper 14 and with the connecting element thus picked up a connection can be made, as described above, between a tugboat or a quay and a ship. This has the advantage that with only one tugboat 2 equipped with a manipulator connections can be made between a ship and different conventionally equipped tugboats or a quay. Such a connection can also be made from a ship equipped with a manipulator according to the invention.

[0042] Figs. 2 and 3 show a mooring installation in the form of a quay 115, provided with manipulators 106 arranged for movement relative to the quay. Like the embodiment shown in Fig. 1, the manipulator 106 shown in Fig. 4 is provided with a turntable 111, a winch 109, an articulated arm 110 and a gripper 114. The manipulator 106 is placed on a movable frame 116, shown in the figure in a strongly simplified form. The articulated arm consists of a number of arm portions 113 telescopically adjustable relative to each other, the lowermost arm portion 113a being slewably connected to a foot part 117. A gripper arm 118 is slewably connected at one end with the uppermost arm portion 113e and at the other end with the slewable gripper 114. The connecting element 107, which preferably consists of a flat webbing, extends from the winch 109 via a pressing mechanism 119 through the articulated arm 110 and the gripper 114. At the free end the webbing 107 is provided with a male coupling part 120 firmly connected therewith. The pressing mechanism 119 and the coupling part 120 will be explained below in more detail.

[0043] Fig. 3 shows, in four steps, a method according to the invention for mooring a ship 101 along a mooring installation, such as a quay 115, by means of manipulators 106.

[0044] The ship 101 is preferably maneuvered to near the quay 115, at least in such a manner that the ship 101 is within range of the manipulators 106 and is

brought to a standstill there. The range of the manipulators 106 can be, e.g., more than 15 m. The articulated arm 110 is then moved out, while the coupling part 120 is put and kept in a desired position by means of the gripper 114. The ship 101 is provided in appropriate positions with female coupling parts 121, which will be explained below in more detail. By means of the manipulator 106 the male coupling part 120 is firmly connected with the female coupling part 121, after which the articulated arm 110 is withdrawn again, and the degrees of movement of the manipulator 106 are released. By winding the webbing 107 on the winch 109 the ship 101 is then drawn to the shore.

[0045] Since at least two manipulators 106 are used simultaneously, the ship 101, with its longitudinal axis L parallel to the quay 115, can be pulled straight to the quay 115, thus resulting in a very favorable direction of pulling. In order to prevent the ship from unintentionally coming into contact with the quay 115, the ship 101 can be connected at the side facing away from the quay 115 with one or more tugboats 102, as shown in Fig. 2, which can stop the ship 101. Of course, these tugboats 102 can be provided with manipulators which correspond to the manipulators 106 placed on the quay 115, but the tugboats can also be designed, e.g., as the tugboat 2 shown in Fig. 1. With the method shown in Fig. 3, a ship 101 can be rapidly and accurately moored in a very safe way, for which relatively simple, thin and light chains, webbings and cables can be used, since the direction of pulling is very favorable.

[0046] The pressing mechanism 119 serves to take up a large part of the forces exerted on the webbing 107, guide the webbing 107, and adjust a constant tension in the webbing 107. In the practical example diagrammatically shown in Fig. 4 the pressing mechanism comprises a number of running rollers 122 through which the webbing 107 is passed. The position of the running rollers 122 is selected to have them exert an adjustable frictional force on the webbing. This frictional force can be adjusted by means of the adjusting mechanism 126, because it brings the running rollers 122 closer to or even farther from each other.

[0047] In the conventionally used winches and such winding mechanisms the connecting element extends directly from the coiling reel in the direction of the ship to be towed or moored. The complete pulling force exerted on the connecting element is then transferred directly to that coiling reel, which has the result that it must be of a very robust construction. Moreover, the force exerted on the reel spindle highly depends on the diameter of the reel and the quantity of connecting element wound on the reel. According as the connecting element wound on the reel gives a larger layer thickness, the moment exerted on the reel increases. Apart from a strongly increasing load on the winch, this has the additional drawback that complicated constructions are necessary to maintain a constant tension in the connecting element. Consequently, the coiling reels of the convention-

ally used winches are of broad and relatively thick construction and the connecting element is wound in layers, each layer consisting of several juxtaposed windings of connecting element. This has the additional drawbacks that upon winding of the connecting element special measures must be taken to wind the connecting element neatly and that upon unwinding of the connecting element the direction of pulling repeatedly changes, and moreover, the risk of chafing of the connecting element is considerably increased.

[0048] In the winch 109 according to the invention the greater part of the tensile force in the webbing 107 is taken up by the running rollers 122. The coiling reel 123 of the winch 109 only serves to wind up and deliver the webbing 107 and is composed of a thin spindle 124 provided with two parallel side flanges 125 disposed at a mutual distance corresponding to the width of the webbing 107 to be wound. Therefore, upon winding of the webbing 107 a number of layers, each consisting of only one webbing 107, are formed between the side flanges. Due to the running rollers 122, the thickness of the wound quantity of webbing 107 does not affect the load on the winch. The small width of the coiling reel 123 has the advantage that the winch can be simply installed, and moreover, that the webbing, seen from the top side, always extends at the same angle from the coiling reel. Consequently, chafing of the webbing is readily prevented.

[0049] The pressing mechanism 119 is described above as a mechanism comprising a number of running rollers 122 and an adjusting mechanism 126. Within the scope of the invention, however, other variants are also possible for the adjustment of this tension, e.g. frictional blocks or, when using a chain as connecting element, braked chain sprockets. Moreover, the running rollers can be put in different positions and another number of running rollers can be used with the same effect.

[0050] In the structural variant shown in Fig. 4 the running rollers move together with the lowermost arm portion 113a of the articulated arm 110. It is thus easily ensured that the webbing 107 always extends through the articulated arm 110, irrespective of the angle at which the lowermost arm portion 113a is inclined to the foot part 117 and the coiling reel 123, thus preventing chafing at the webbing 107 and undesirable load on the articulated arm 110.

[0051] In the embodiment of the manipulator 106 shown in Fig. 4 the gripper can cover an area located within a segment of spherical segment which is determined by the angle of rotation of the table 111 (e.g. 360°), the length of the fully stretched articulated arm 110 (e.g. 20 m), the maximum angle at which the lowermost arm portion 113 can be inclined to the foot part 117 (e.g. between 100° upwards and 60° downwards) and the angles at which the gripper arm 118 can be inclined to the uppermost arm portion 113e, and the gripper 114 to the gripper arm 118 (e.g. $\pm 100^\circ$ in the horizontal and $\pm 100^\circ$ in the vertical plane).

[0052] When mooring and towing ships, the deck 4 of the ship 1, 101 is often considerably higher than the deck 12 of the tugboat 2, 102 or than the quay 115 or comparable mooring installation. Apart from the usual problems arising when bringing on board the connecting element, the known use of connecting elements results in a very disadvantageous direction of pulling, not only in the horizontal direction but in particular also in the vertical direction. Consequently, the connecting element is loaded more heavily than would be necessary in principle to tow the ship, but moreover, during pulling the relatively low weight of the tugboat as compared with the ship causes the tugboat to be partly drawn from the water, as a result of which the full towing capacity of the tugboat cannot be used optimally without taking additional measures.

[0053] In the assembly according to the invention, as clearly shown in Fig. 3, the ship 101 is provided with a row of female coupling parts 121 at some distance below the deck. In general, these coupling parts 121 cannot be reached from the deck without auxiliaries, which substantially reduces the risk of accidents during fastening and unfastening the connecting elements 107. The female coupling parts 121 are located low and preferably near the waterline of the ship 101, recessed in the skin 127, thus preventing them from being damaged. Moreover, the female coupling parts 121 are provided around the ship 101 so that connecting elements 107 can be coupled in appropriate positions. With very large ships and such objects of relatively great height located on or in the water and with ships having a rather large difference in draft between loaded and light, the ship is advantageously provided with several rows of superimposed female coupling parts.

[0054] A simple arithmetic example teaches that when the tugboat is at a distance from the ship equal to the difference of level between the deck 12 of the tugboat 2 and the deck 4 of the ship 1 (e.g. both 12 m) the tension in a connecting element fastened to both decks, which connecting element therefore extends at an angle of approximately 45° located in the vertical plane, is at least 1.4 times as high as in a connecting element which extends in approximately horizontal direction, as shown in Fig. 3. When a tugboat is located closer to the ship 1 or when the ship is moored close to a quay, this difference only increases. The assembly according to the invention enables easy fastening in case of the connecting element extending almost horizontally, in particular when using the coupling assembly according to the invention, as particularly shown in Figs. 5 - 8.

[0055] Fig. 5 shows, in front elevation, the female coupling part 121, and Fig. 6 shows, in cross-sectional top plan view, the female and the male coupling part 121, 120 in coupled condition. The male coupling part 120 consists of a spherical segment shaped part 128 firmly connected to one end of the connecting element 107, the convex outer surface 129 facing towards the connecting element 107. The connecting element can in

principle be any type of connecting element. The female coupling part 121 comprises a slot 130, which slot is provided with a first slot portion 131 which is wider than the maximum width of the male part 120, and a second slot portion 132 which is narrower than that maximum width. The first slot portion 131 blends with the top side of the second slot portion 132. The female part 121 further comprises a recess 133 extending behind the slot and having such dimensions that the male part 120 can be freely received therein.

[0056] In the embodiment shown in the figure the male part 120 is composed of a hollow spherical part 134 which is provided with a central opening 135. The connecting element 107 extends through the opening, over the end of which connecting element 107 a pin part 136 having a central bore is placed from the concave side of the spherical part 134. The pin part has a frusto-conical portion 137 which can be tightly received in the central opening 135 and a flange 138 extending from the wide end of the frusto-conical portion, which flange 138 can abut against the concave inside of of the spherical part 134. The pin part can be connected with the connecting element 107 in many ways, such as welding, pressing or glueing, or can be clamped in the central opening 135 by means of the pin part 136. The spherical part 134 is preferably larger than a semisphere.

[0057] In the embodiments shown in Fig. 5, 6 and 7 the female part 121 is composed of a box-shaped shell part 139, preferably mounted with the open side against the inside of a skin 127. The shell part 139 is covered with a plate part 140 which is approximately in the same plane as the skin 127 or part thereof. Consequently, the female part does not project from the ship so as to minimize the risk of damage. Into the plate part 140 the slot 130 is formed. The edges of the slot 130 are formed by an anti-chafing/buckling tube 141 welded against the inside of the plate part 140, the curved outer surface 142 of which forms a blending abutting face for the connecting element 107. A leader collar 143 slopes inwards from the anti-chafing/buckling tube 141, which leader collar 143, at the end remote from the anti-chafing/buckling tube 141, connects to a likewise circular abutting tube 144, which is substantially parallel to the anti-chafing/buckling tube 141. The recess 133, which is enclosed between the abutting tube 144 and the back wall 145 of the box-shaped shell part 139, has such dimensions that the male part 120 can move and rotate therein clear of the walls and the abutting edge at least in the longitudinal direction of the slot.

[0058] The coupling assembly according to the invention can be used as follows.

[0059] The male part 120 is brought into the recess 133 via the first (upper) slot portion 131, the connecting element 107 extending beyond the slot 130. Then the male part 120 is moved downwards, in such a manner that it is located behind the second slot portion 132 and the connecting element 107 extends through the second slot portion 132. The convex surface 129 of the

spherical part 134 then abuts against the side of the abutting tube 144 facing away from the exterior of the ship 1. When a pulling force is exerted on the connecting element 107 in the direction away from the male part 120, this force is transferred to the abutting tube 144, and thus to the ship 101, so that, for instance, the ship 101 can be towed or moored via the connecting element 107 and the coupling assembly. Since the narrow second slot portion 132 is located at the bottom side, the male part 120 is kept in the coupling position by gravity.

[0060] When a force is exerted on the portion of the connecting element 107 extending beyond the ship in the forward, backward or downward directions seen in the direction of the ship, the connecting element is deflected along the curved surface 142 of the anti-chafing/buckling tube 141, thus preventing damage to the connecting element 107 at least substantially. The convex surface 129 of the spherical part 134 then enables slight rotation of the male part 120 within the female part 121, thus preventing buckling of the connecting element 107 at least near the spherical part 134, since the portion of the connecting element located close to the spherical part 134 will always extend parallel to the axis H of the central opening 135 of the spherical part 134, optionally parallel to the leader collar 143.

[0061] When breaking the connection between the male part 120 and the female part 121, and thus between the ship 101 and the connecting element 107, the male part 120 is moved upwards parallel to the longitudinal direction of the slot 130, until the male part 120 can be drawn from the recess 133 via the first slot portion 131.

[0062] If the connection can be broken without haste, then the male part 120 can be easily gripped, e.g. with the gripper 14, 114 of a manipulator 6, 106, or optionally using the hands, and can then be lifted in the recess 133. If, however, the connection must be broken without delay or the female part 121 is in a position which cannot be easily reached, then it is particularly advantageous if the female part 121 is designed as an "active" coupling point, e.g. as shown in Fig. 7. An "active" coupling point means that the male part 120 can be released from the female part 121 mechanically, without it being necessary to grip the male part 120 or the connecting element 107 from outside the recess 133.

[0063] The female part 121, as shown in Fig. 7, comprises a hydraulic push-out piston 146 partly extending into the recess. In a first, withdrawn position the top side 147 of the push-out piston 146 is located below the second slot portion 132, so that the spherical part 134, abutting against the top side 147, can be received behind the second slot portion 132. If the male part 120 must be released from the female part 121, then the push-out piston 146 is energized, so that the top side 147 with the spherical part 134 lying thereon is pushed up along the slot 130, until the spherical part 134 lies behind the first slot portion 131 and can be

drawn therethrough from the recess 133. The push-out piston is remote-controlled, preferably both from the tugboat 102 or the quay 115 and from the ship 101, thus enabling both the user of the tugboat 102 or quay 115 and the user of the ship 101 to break the coupling in case of emergency or at any other moment. Moreover, an "active" coupling point enables a connection between sailing ships to be easily and safely broken.

[0064] With the coupling assembly according to the invention, as shown in Figs. 5 - 7, and with a manipulator according to the invention a connection can be made as follows.

[0065] The male part 120 is gripped by means of the gripper 14, 114 of a manipulator 6, 106 and brought to near a skin 127, preferably above a female part 121. Then the gripper is moved along the skin towards the female part. As soon as the male part passes the anti-chafing/buckling tube 141, the spherical part 134 will be guided by the leader collar 143 into the recess behind the slot 130, after which the spherical part 134 will be received behind the second slot portion 132 by moving the gripper further down and the connection is made. The male part can then be released, after which the gripper can be withdrawn. This method of making the connection has the advantage that the connection can be easily made in nearly all conditions, in particular because the movements of the gripper relative to the ship are then minimized.

[0066] Unexpected movements of the ship relative to the mooring installation 115 or the tugboat 2, 102, and in particular relative to the manipulator 6, 106 involve the risk of the manipulator 6, 106, and in particular the gripper 14, 114, coming into sharp and undesirable contact with the ship, which may cause damage to both the ship and the manipulator. In a particularly advantageous embodiment of the manipulator this manipulator is therefore provided with overpressure protections ensuring that when certain optionally adjustable forces exerted on the manipulator are exceeded, the possibilities of movement of the manipulator are at least partly released. As a result, the manipulator cannot exert forces on the ship (or on other objects or persons) greater than these adjusted forces, so that damage is prevented. Since no pulling or other forces are exerted with the manipulator on the fastening element, these overpressure protections do not restrict the towing capacity of the tugboat or the mooring installation.

[0067] Fig. 8 shows an alternative embodiment of the female coupling part 221, in particular suitable for being mounted on a deck of a ship. In this embodiment the slot 230 is open at the top side and substantially has a width smaller than the maximum width of the male part 120. This alternative embodiment of the female part 221 also comprises, in a comparable manner, an anti-chafing/buckling tube 241, a leader collar 243, and an abutting tube 244, which are all connected at the bottom side with a baseplate 250 connected with the deck

204 of a ship. At some distance behind the abutting tube 244 an abutting edge 251 is mounted at the top side of the baseplate 250, which abutting edge 251 extends over a substantial portion of the width of the baseplate 250. Besides, the female part 221 is fully open.

[0068] During use of the embodiment of the coupling assembly shown in Fig. 8 the male part 120 can be easily brought above the female part 221 and then moved downwards so that the spherical part 134 is located behind the abutting tube 244 and the connecting element 107 extends through the slot 230. The spherical part 134 can then abut against the abutting edge 251 with its back, thus preventing the spherical part 134 from moving in the direction away from the abutting tube 244.

[0069] In order to break the connection thus formed, the male part 120 can be easily moved away upwards behind the slot. Moreover, such a female part can be easily designed as an "active" coupling point. To this end, a push-out cylinder can be used, as shown in Fig. 7, but besides, the female part may also be tiltably positioned. The slot 230 is then tiltably connected with the deck 204 towards the connecting element, so that the slot 230 can be tilted in a substantially horizontal plane, parallel to the deck 204 projecting therefrom, or farther. The male part 120 can then be withdrawn along the abutting tube 244 in approximately horizontal direction.

[0070] In order to advantageously simplify coupling of the female part 121, 221 and the male part 120, the manipulator 6, 106 is provided with positioning means 150 (Fig. 3A which can cooperate with manipulator directing means 151, which are arranged near a female part 121. Through the positioning means 150, e.g. a signal source and receiver, and the manipulator directing means 151, e.g. a signal reflector, the gripper can be positioned relative to the female part 121 independently of the movements of the tug relative to the tow, the movements for coupling preferably being carried out via a control program. In this manner, coupling of the coupling assembly, and thus making a connection between, e.g., a tugboat or a quay and a ship, can be carried out largely or even fully automatically. Besides, it is of course also possible to carry out the positioning and manipulator directing means in a different way, e.g. a transmitter located near the female part and a receiver attached to the manipulator, or e.g., by using positioning coordinates or pattern recognition.

[0071] The invention is by no means limited to the practical examples given in the description and the drawings. For instance, there can be used other manipulators having more or fewer possibilities of movement, and moreover, e.g., a coupling rod or a coupling hook can also be manipulated with the manipulator according to the invention. Furthermore, the winch, for instance, may be designed to receive two or three windings per layer, so that a greater length of webbing can be wound on a coiling reel that is relatively small in cross-section,

while largely retaining the above advantages, though. In the coupling assembly according to the invention the male part may be connected with the connecting element in a different way, and the female part may have a different shape. Within an assembly according to the invention a tugboat may be provided with another manipulator or the ship may be equipped therewith, and a mooring installation may be provided with female coupling parts.

[0072] With an assembly and a method according to the invention it is obtained that a good connection can be made between a tow and a tug with a minimum of human effort in a rapid, accurate, safe and economic way.

Claims

1. A method of manipulating in towing an elongated flexible connecting element (7,107), such as a tow rope, provided at one end with a coupling element (8,120) and connected at the opposite end with a coiling device (9,109), at least the coupling element (8,120) of at least one connecting element (7,107) being moved by means of a manipulator (6,106) between an object (2,115), called tug, and an object to be towed (1) called tow, and being fastened to the tow (1,101) or unfastened therefrom, the length of the part of the connecting element (7,107) extending between the tug (2,115) and the tow (1,101) then being adjustable by means of the coiling device (9,109), characterized in that the coupling element (8,120) is gripped in direct contact with the manipulator and manipulated in such a manner that the coupling element (8,120) is controlled for movement from the tug (2,115) to the tow (1,101) and fastened to the tow (1,101) by means of the manipulator (6,106), after which the manipulator (6,106) is drawn away from the coupling element (8,120) and brought into an at least partly retracted storing position.
2. A method according to claim 1, characterized in that the unfastening of the coupling element (8,120) is manipulator-controlled.
3. A method according to any of the preceding claims, characterized in that the manipulator (6,106) is remote-controlled, preferably radio-controlled.
4. A method according to any of claims 1 - 3, characterized in that the coupling element (8,120) is fastened to the tow (1,110) in a position that cannot be reached by people from a deck (4) of the tow without using auxiliaries.
5. A method according to any of the preceding claims, characterized in that the coupling element (8,120) is fastened near the waterline of the tow, preferably at about the same level as the tug (2,115).
6. A method according to any of the preceding claims, characterized in that the coupling element (8,120) is brought by means of the manipulator (6,106) to near a side (127) of the tow, part of which manipulator (6,106) or coupling element (8,120) is contacted with the side, after which the contacting part is passed along the wall to near a fastening point (5,121,221) on the tow, in such a manner that part of the coupling element (8,120) can be received in or around it
7. An assembly of an object, called tug (2,115), an object to be towed, called tow (1,101), and an elongated flexible connecting element (7,107) provided at one end with a coupling element (8,120) and at the opposite end with a coiling device (9,109) and designed to make a firm connection between the tug and the tow, which assembly comprises a manipulator (6,106) provided with a gripper element (14,114) capable of gripping the coupling element (8,120) in direct contact and moving it between the tug (2,115) and an adjacent tow (1,101), in such a manner that the coupling element (8,120) can be moved between the tug and the tow by manipulating the coupling element (8,120) by means of the manipulator (6,106), characterized in that the manipulator (6,106) comprises an articulated arm (10,110) provided at one end with the gripper element (14,114), which articulated arm is foldable or retractable, independently of the connecting element (7,107), in such a manner that the coupling element (8,120) can be gripped in direct contact with the gripper element (14,114) and can be coupled by controlling by means of the manipulator (6,106) or uncoupled from a fastening means (5,121,221) on or at the tow (2,115) and after retracting or folding the articulated arm (10,110) after coupling of the coupling element (8,120) with the fastening element (5,121,221) by the connecting element the connection is made between a tug and a tow, while after unfolding or extending the articulated arm (10,110) the coupling element (8,120) can again be gripped with the gripper element (14,114), optionally after adjusting the length of the connecting element (7,107) by means of the coiling device (9,109).
8. An assembly according to claim 7, characterized in that the manipulator (6,106) is provided with positioning means for positioning the gripper element (14,114) independently of the movements of the tug relative to the tow, which means are designed for co-operation with manipulator-directing means mounted on the tow.
9. An assembly according to claim 8, characterized in

- that the positioning means comprise a signal source and associated receiving means, while the manipulator-directing means comprise reflecting means for directed reflection, in use, of the irradiation emitted by the signal source, in such a manner that on the basis of a signal emitted and received back the gripper can be automatically brought to near a fastening point on the tow.
10. An assembly according to any of claims 7 - 9, characterized in that the articulated arm at least comprises a number of parts capable of telescopically moving relative to each other.
11. An assembly according to any one of claims 7 - 10, characterized in that the manipulator is positioned on a preferably mainly vertical axis of rotation.
12. An assembly according to any of claims 7 - 11, characterized in that the manipulator is provided with overpressure protections designed to at least partly release at least part of the degrees of freedom of the manipulator when a predetermined force to be maximally exerted on the gripper element is exceeded.
13. An assembly according to any of claims 7 - 12, characterized in that, at least in use, the connecting element extends at least partly through the manipulator.
14. An assembly according to any of claims 7 - 13, characterized in that the coiling device is firmly connected with the manipulator, in such a manner that the coiling device follows the movements of the manipulator around the axis of rotation.
15. An assembly according to any of claims 7 - 14, comprising a winch, wherein the winch is provided with an adjusting mechanism (119,126) for maintaining, during use or the connecting element, a constant tension in the connecting element, which tension is adjustable.
16. An assembly according to claim 15, characterized in that the winch (9,109) is provided with a coiling reel (125) and a number of running rollers (119,122), the connecting element (7,107) extending, at least in use, from the coiling reel (125) through the running rollers (119,122).
17. An assembly according to claims 15 and 16, characterized in that the adjusting mechanism (119) comprises the running rollers (122), which are provided with a pressing mechanism (126) for exerting a frictional force via the running rollers (122) on the connecting element (7,107), the pressing mechanism being adjustable in such a manner that, in use, the tension in the connecting element is independent of the quantity of connecting element wound on the coiling reel.
18. An assembly according to claims 15 - 17, characterized in that the connecting element (7,107) comprises a substantially flat, webbing shaped part, the coiling reel (125) being provided with two side flanges placed at a mutual distance which approximately corresponds to the width of the webbing shaped part.
19. A coupling assembly for use in a method according to any of claims 1 - 6, or with an assembly according to any one of claims 7 - 18 which coupling assembly at least comprises a connecting element (7,107) that can be connected at one side with a tug, characterized in that the connecting element is provided near a free end with a spherical segment shaped male part (128), the convex surface of which is directed to the connecting element (7,107), which male part (120,128) can be received in a slot shaped female part (121), which can be firmly connected to a tow to be coupled, the slot being provided with a first part (131) that is wider and with a second part (132) that is narrower than the maximum width of the male part (120), and the female part covering a recess (133), the male part in a first position being freely movable through the first portion (132) of the slot (130,230) into and out of the recess (133) and in a second position being retained in the recess (133) by the edges of the slot (130,230), in such a manner that in the second position of the male part (120) the fastening element (7,107) extends through the slot (130,230), the male part (120) being slightly rotatable within the recess (133).
20. A coupling assembly according to claim 19, characterized in that the female part (121) extends substantially vertically, the narrower second portion (132) of the slot (130,230) being located at the bottom side.
21. A coupling assembly according to claim 19 or 20, characterized in that means (146,147) are included for mechanically releasing the male part from the female part.
22. A coupling assembly according to claim 21, characterized in that the means for releasing comprise a preferably hydraulically operating push-out piston (146) designed to move the male part (120) from the second position into the first position.
23. A coupling assembly according to claim 22, characterized in that the means for releasing at least comprise a number of parts determining the slot

(130,230), which parts are arranged for movement in such a manner that the slot width can thereby be increased to more than the maximum width of the male part (120).

24. A coupling assembly according to claim 21, characterized in that the means for releasing at least comprise tilting parts determining the slot (130,230).

Patentansprüche

1. Verfahren zum Manipulieren beim Ziehen eines langgestreckten elastischen Verbindungselements (7,107), z. B. eines Schlepptaus, das an einem Ende ein Kupplungselement (8,120) aufweist und am gegenüberliegenden Ende mit einer Aufwickelvorrichtung (9,109) verbunden ist, wobei zumindest das Kupplungselement (8,120) mindestens eines Verbindungselements (7,107) von einem Manipulator (6,106) zwischen einem als Schlepper bezeichneten Objekt (2,115) und einem als Schleppanhang bezeichneten zu schleppenden Objekt (1) bewegt und an dem Schleppanhang (1,101) befestigt oder von diesem gelöst wird, wobei die Länge des Teils des Verbindungselements (7,107), der zwischen dem Schlepper (2,115) und dem Schleppanhang (1,101) verläuft, von der Aufwickelvorrichtung (9,109) einstellbar ist, dadurch gekennzeichnet, dass das Kupplungselement (8,120) in direktem Kontakt mit dem Manipulator gegriffen und derart manipuliert wird, dass die Bewegung des Kupplungselements (8,120) vom Schlepper (2,115) zum Schleppanhang (1,101) gesteuert und das Kupplungselement (8,120) durch den Manipulator (6,106) an dem Schleppanhang (1,101) befestigt wird, wonach der Manipulator (6,106) von dem Kupplungselement (8,120) weggezogen und in eine zumindest teilweise zurückgezogene Aufbewahrungsposition gebracht wird.
2. Verfahren nach Anspruch 1, dadurch gekennzeichnet, dass das Lösen des Kupplungselements (8,120) vom Manipulator gesteuert wird.
3. Verfahren nach einem der vorhergehenden Ansprüche, dadurch gekennzeichnet, dass der Manipulator (6,106) ferngesteuert, vorzugsweise funkgesteuert ist.
4. Verfahren nach einem der Ansprüche 1-3, dadurch gekennzeichnet, dass das Kupplungselement (8,120) an dem Schleppanhang (1,101) in einer Position befestigt wird, die für auf einem Deck (4) des Schleppanhangs befindliche Personen ohne Einsatz von Hilfsmitteln nicht erreichbar ist.
5. Verfahren nach einem der vorhergehenden Ansprü-

che, dadurch gekennzeichnet, dass das Kupplungselement (8,120) nahe der Wasserlinie des Schleppanhangs, vorzugsweise ungefähr auf Höhe des Schleppers (2,115) befestigt ist.

6. Verfahren nach einem der vorhergehenden Ansprüche, dadurch gekennzeichnet, dass das Kupplungselement (8,120) mit dem Manipulator (6,106) in die Nahe einer Seite (127) des Schleppanhangs gebracht wird, wobei ein Teil des Manipulators (6,106) oder des Kupplungselements (8,120) die Seite berührt, wonach der berührende Teil derart entlang der Wand in die Nähe einer Befestigungsstelle (5,121,221) an dem Schleppanhang gebracht wird, dass ein Teil des Kupplungselements (8,120) in dieser Befestigungsstelle (5,121,221) oder um diese Befestigungsstelle (5,121,221) herum aufgenommen werden kann.
7. Anordnung aus einem als Schlepper (2,115) bezeichneten Objekt, einem als Schleppanhang (1,101) bezeichneten zu schleppenden Objekt und einem langgestreckten elastischen Verbindungselement (7,107), das an einem Ende ein Kupplungselement (8,120) und am gegenüberliegenden Ende eine Aufwickelvorrichtung (9,109) -aufweist und derart konfiguriert ist, dass eine feste Verbindung zwischen dem Schlepper und dem Schleppanhang entsteht, wobei die Anordnung einen Manipulator (6,106) mit einem Greifelement (14,114) aufweist, das das Kupplungselement (8,120) in direktem Kontakt greifen und zwischen dem Schlepper (2,115) und einem benachbarten Schleppanhang (1,101) derart bewegen kann, dass das Kupplungselement (8,120) durch Manipulieren des Kupplungselements- (8,120) mittels des Manipulators (6,106) zwischen dem Schlepper und dem Schleppanhang bewegbar ist, dadurch gekennzeichnet, dass der Manipulator (6,106) einen Gelenkarm (10,110) aufweist, der an einem Ende mit dem Greifelement (14,114) versehen ist, wobei der Gelenkarm unabhängig vom Verbindungselement (7,107) derart zusammenlegbar oder zurückziehbar ist, dass das Kupplungselement (8,120) in direktem Kontakt mit dem Greifelement (14,114) gegriffen und durch Steuerung mittels des Manipulators (6,106) an einer Befestigungseinrichtung (5,121,221) auf oder an dem Schleppanhang (1,101) gekoppelt oder von dieser entkoppelt werden kann, und nach dem Zurückziehen oder Zusammenlegen des Gelenkarms (10,110) nach dem Koppeln des Kupplungselements (8,120) an dem Befestigungselement (5,121,221) durch das Verbindungselement die Verbindung zwischen einem Schlepper und einem Schleppanhang erfolgt, während wahlweise nach dem Einstellen der Länge des Verbindungselements (7,107) durch die Aufwickelvorrichtung

- (9,109) das Kupplungselement (8,120) nach dem Auseinanderziehen oder Ausfahren des Gelenkarms (10,110) wieder vom Greifelement (14,114) gegriffen werden kann.
8. Anordnung nach Anspruch 7, dadurch gekennzeichnet, dass der Manipulator (6,106) eine Positioniereinrichtung zum Positionieren des Greifelements (14,114) unabhängig von den Bewegungen des Schleppers relativ zu dem Schleppanhang aufweist, wobei die Einrichtung derart konfiguriert ist, dass sie mit der an dem Schleppanhang befestigten und den Manipulator führenden Einrichtung kooperiert.
9. Anordnung nach Anspruch 8, dadurch gekennzeichnet, dass die Positioniereinrichtung eine Signalquelle und eine dieser zugeordnete Empfangseinrichtung aufweist, während die den Manipulator führende Einrichtung eine Reflexionseinrichtung zur gerichteten Reflexion der von der Signalquelle ausgesandte Strahlung aufweist, derart, dass auf der Basis eines ausgesandten und empfangenen Signals der Greifer automatisch in die Nähe der Befestigungsstelle am Schleppanhang gebracht werden kann.
10. Anordnung nach einem der Ansprüche 7-9, dadurch gekennzeichnet, dass der Gelenkarm mindestens eine Anzahl von Teilen aufweist, die teleskopartig relativ zueinander bewegt werden können.
11. Anordnung nach einem der Ansprüche 7-10, dadurch gekennzeichnet, dass der Manipulator auf einer vorzugsweise im wesentlichen vertikalen Drehachse positioniert ist.
12. Anordnung nach einem der Ansprüche 7-11, dadurch gekennzeichnet, dass der Manipulator einen Überdruckschutz aufweist, der derart konfiguriert ist, dass er zumindest teilweise mindestens einen Teil des Freiheitsgrads des Manipulators freigibt, wenn eine maximal auf das Greifelement aufzubringende vorbestimmte Kraft überschritten wird.
13. Anordnung nach einem der Ansprüche 7-12, dadurch gekennzeichnet, dass zumindest beim Einsatz das Verbindungselement mindestens teilweise durch den Manipulator verläuft.
14. Anordnung nach einem der Ansprüche 7-13, dadurch gekennzeichnet, dass die Aufwickelvorrichtung fest mit dem Manipulator verbunden ist, derart, dass die Aufwickelvorrichtung den Bewegungen des Manipulators um die Drehachse folgt.
15. Anordnung nach einem der Ansprüche 7-14, die eine Winde aufweist, welche mit einem Einstellmechanismus (119,126) zum Beibehalten einer konstanten Spannung des Verbindungselements während des Einsatzes des Verbindungselements versehen ist, wobei die Spannung einstellbar ist.
16. Anordnung nach Anspruch 15, dadurch gekennzeichnet, dass die Winde (9,109) eine Aufwickelrolle (125) und eine Anzahl von Laufrollen (119,122) aufweist, wobei das Verbindungselement (7,107) zumindest beim Einsatz von der Aufwickelrolle (125) durch die Laufrollen (119,122) verläuft.
17. Anordnung nach Anspruch 15 und 16, dadurch gekennzeichnet, dass der Einstellmechanismus (119) die Laufrollen (122) aufweist, die mit einem Pressmechanismus (126) zum Aufbringen einer Reibkraft über die Laufrollen (122) auf das Verbindungselement (7,107) versehen sind, wobei der Pressmechanismus derart einstellbar ist, dass beim Einsatz die Spannung des Verbindungselements von der Menge an auf die Aufwickelrolle gewickelten Verbindungselements unabhängig ist.
18. Anordnung nach Anspruch 15-17, dadurch gekennzeichnet, dass das Verbindungselement (7,107) ein im wesentlichen flaches gurtförmiges Teil aufweist, wobei die Aufwickelrolle (125) mit zwei Seitenflanschen versehen ist, die in einem Abstand, der ungefähr der Breite des gurtförmigen Teils entspricht, zueinander angeordnet sind.
19. Kupplungsanordnung zum Einsatz in einem Verfahren nach einem der Ansprüche 1-6 oder zusammen mit einer Anordnung nach einem der Ansprüche 7-18, wobei die Kupplungsanordnung mindestens ein Verbindungselement (7,107) aufweist, das auf einer Seite mit einem Schlepper verbindbar ist, dadurch gekennzeichnet, dass das Verbindungselement nahe einem freien Ende mit einem kugelsegmentförmigen vorstehenden Teil (128), dessen konvexe Oberfläche in Richtung auf das Verbindungselement (7,107) zeigt, versehen ist, wobei das vorstehende Teil (120,128) in einem schlitzförmigen aufnehmenden Teil (121) aufgenommen und mit einem anzukoppeinden Schleppanhang fest verbunden werden kann, wobei der Schlitz einen ersten Teil (131) aufweist, der breiter ist, und einen zweiten Teil (132) aufweist, der schmaler ist als die maximale Breite des vorstehenden Teils (120), und der aufnehmende Teil eine Ausnehmung (133) abdeckt, wobei der vorstehende Teil in einer ersten Position frei durch den ersten Teil (132) des Schlitzes (130,230) in die Ausnehmung (133) und aus dieser heraus bewegbar ist, und in einer zweiten Position von den Rändern des Schlitzes (130,230) derart in der Ausnehmung (133) gehalten wird, dass in der zweiten Position

des vorstehenden Teils (120) das Befestigungselement (7,107) durch den Schlitz (130,230) verläuft, wobei der vorstehende Teil (120) innerhalb der Ausnehmung (133) leicht gedreht werden kann.

- 5
20. Kupplungsanordnung nach Anspruch 19, dadurch gekennzeichnet, dass der aufnehmende Teil (121) im wesentlichen vertikal verläuft, wobei sich der schmalere zweite Bereich (132) des Schlitzes (130,230) auf der Unterseite befindet. 10
21. Kupplungsanordnung nach Anspruch 19 oder 20, dadurch gekennzeichnet, dass eine Einrichtung (146,147) zum mechanischen Freigeben des vorstehenden Teils aus dem aufnehmenden Teil vorgesehen ist. 15
22. Kupplungsanordnung nach Anspruch 21, dadurch gekennzeichnet, dass die Freigabeeinrichtung einen vorzugsweise hydraulischen Druckkolben (146) aufweist, der derart konfiguriert ist, dass er den vorstehenden Teil (120) aus der zweiten Position in die erste Position bewegt. 20
23. Kupplungsanordnung nach Anspruch 22, dadurch gekennzeichnet, dass die Freigabeeinrichtung mindestens eine Anzahl von den Schlitz (130,230) bildenden Teilen aufweist, die derart angeordnet sind, dass durch ihre Bewegung die Schlitzbreite auf mehr als die maximale Breite des vorstehenden Teils (120) vergrößert werden kann. 25 30
24. Kupplungsanordnung nach Anspruch 21, dadurch gekennzeichnet, dass die Freigabeeinrichtung mindestens den Schlitz (130,230) bildende Kippteile aufweist. 35

Revendications

1. Procédé de manipulation lors du remorquage d'un élément souple allongé de raccordement (7, 107), tel qu'une corde de remorquage, muni à une première extrémité d'un élément d'accouplement (8, 120) et raccordé à l'extrémité opposée à un dispositif d'enroulement (9, 109), l'élément d'accouplement au moins (8, 120) d'au moins un élément de raccordement (7, 107) étant déplacé à l'aide d'un manipulateur (6, 106) placé entre un objet (2, 115), appelé remorqueur, et un objet à remorquer (1), appelé remorque, et étant fixé à la remorque (1, 101) ou non, la longueur de la partie de l'élément de raccordant (7, 107) qui s'étend entre le remorqueur (2, 115) et la remorque (1, 101) étant alors réglable à l'aide du dispositif d'enroulement (9, 109), caractérisé en ce que l'élément d'accouplement (8, 120) est saisi par contact direct à l'aide du manipulateur et est manipulé afin que l'élément d'accouplement (8, 120) soit commandé pour se déplacer depuis le remorqueur (2, 115) vers la remorque (1, 101) et soit fixé à la remorque (1, 101) par le manipulateur (6, 106), puis le manipulateur (6, 106) est tiré à distance de l'élément d'accouplement (8, 120) et est mis en position au moins partiellement reculée de rangement. 5
2. Procédé selon la revendication 1, caractérisé en ce que la séparation de l'élément d'accouplement (8, 120) est commandée par le manipulateur. 10
3. Procédé selon l'une quelconque des revendications précédentes, caractérisé en ce que le manipulateur (6, 106) est commandé à distance, de préférence radioélectriquement. 15
4. Procédé selon l'une quelconque des revendications 1 à 3, caractérisé en ce que l'élément d'accouplement (8, 120) est fixé à la remorque (1, 110) à un emplacement qui ne peut pas être atteint par des personnes à partir d'un pont (4) de la remorque sans utilisation d'accessoires. 20
5. Procédé selon l'une quelconque des revendications précédentes, caractérisé en ce que l'élément d'accouplement (8, 120) est fixé près de la ligne de flottaison de la remorque, de préférence à peu près au même niveau que le remorqueur (2, 115). 25
6. Procédé selon l'une quelconque des revendications précédentes, caractérisé en ce que l'élément d'accouplement (8, 120) est placé par le manipulateur (6, 106) à proximité d'un côté (127) de la remorque, une partie du manipulateur (6, 106) ou de l'élément d'accouplement (8, 120) est mise au contact du côté, puis la partie en contact passe le long de la paroi vers la proximité du point de fixation (5, 121, 221) sur la remorque, de manière qu'une partie de l'élément d'accouplement (8, 120) puisse être logée à l'intérieur ou autour de celle-ci. 30
7. Ensemble d'un objet, appelé remorqueur (2, 115), d'un objet à remorquer, appelé remorque (1, 101), et d'un élément souple allongé de raccordement (7, 107) muni à une première extrémité d'un élément d'accouplement (8, 120), et, à l'extrémité opposée, d'un dispositif d'enroulement (9, 109) et destiné à réaliser un raccord robuste entre le remorqueur et la remorque, l'ensemble comprenant un manipulateur (6, 106) muni d'un élément à organe de saisie (14, 114) qui peut saisir l'élément d'accouplement (8, 120) par contact direct et le déplacer entre le remorqueur (2, 115) et une remorque adjacente (1, 101), de manière que l'élément d'accouplement (8, 120) puisse être déplacé entre le remorqueur et la remorque par manipulation de l'élément d'accouplement (8,120) à l'aide du manipulateur (6, 106), 35 40 45 50 55

- caractérisé on ce que le manipulateur (6, 106) comporte un bras articulé (10, 110) muni à une première extrémité de l'élément à organe de saisie (14, 114), le bras articulé pouvant être plié ou reculé, indépendamment de l'élément de raccordement (7, 107), d'une manière telle que l'élément d'accouplement (8, 120) peut être saisi directement au contact par l'élément à organe de saisie (14, 114) et peut être couplé par commande à l'aide du manipulateur (6, 106) à un dispositif de fixation (5, 121, 221) placé sur la remorque (2, 115) ou au niveau de celle-ci ou désaccouplé de ce dispositif de fixation et, après recul ou pliage, le bras articulé (10, 110), après recul ou pliage du bras articulé (10, 110) après l'accouplement de l'élément d'accouplement (8, 120) à l'élément de fixation (5, 121, 221) par l'élément de raccordement, la connexion est réalisée entre un remorqueur et une remorque alors que, après dépliage ou allongement du bras articulé (10, 110), l'élément d'accouplement (8, 120) peut à nouveau être saisi par l'élément à organe de saisie (14, 114), éventuellement après ajustement de la longueur de l'élément de raccordement (7, 107) à l'aide du dispositif d'enroulement (9, 109).
8. Ensemble selon la revendication 7, caractérisé en ce que le manipulateur (6, 106) comporte un dispositif de positionnement de l'élément à organe de saisie (14, 114) indépendamment des mouvements du remorqueur par rapport à la remorque, le dispositif étant destiné à coopérer avec un dispositif de direction de manipulateur monté sur la remorque.
9. Ensemble selon la revendication 8, caractérisé en ce que le dispositif de positionnement comporte une source de signaux et un dispositif associé de réception, alors que le dispositif de direction de manipulateur comporte un dispositif réflecteur destiné à diriger, pendant l'utilisation, la réflexion du rayonnement émis par la source de signaux de manière que, d'après un signal émis et reçu, l'organe de saisie puisse être placé automatiquement à proximité du point de fixation sur la remorque.
10. Ensemble selon l'une quelconque des revendications 7 à 9, caractérisé en ce que le bras articulé comporte au moins un certain nombre de parties capables de se déplacer télescopiquement les unes par rapport aux autres.
11. Ensemble selon l'une quelconque des revendications 7 à 10, caractérisé en ce que le manipulateur est positionné sur un axe de préférence essentiellement vertical de rotation.
12. Ensemble selon l'une quelconque des revendications 7 à 11, caractérisé en ce que le manipulateur comporte des protections de surpression destinées, à libérer au moins partiellement une partie au moins des degrés de liberté du manipulateur lorsqu'une force prédéterminée comme pouvant être appliquée au maximum à l'élément à organe de saisie est dépassée.
13. Ensemble selon l'une quelconque des revendications 7 à 12, caractérisé en ce que, au cours pendant l'utilisation, l'élément de raccordement s'étend au moins en partie dans le manipulateur.
14. Ensemble selon l'une quelconque des revendications 7 à 13, caractérisé en ce que le dispositif d'enroulement est fermement raccordé au manipulateur d'une manière telle que le dispositif d'enroulement suit les mouvements du manipulateur autour de l'axe de rotation.
15. Ensemble selon l'une quelconque des revendications 7 à 14, comprenant un treuil, dans lequel le treuil a un mécanisme d'ajustement (119, 126) destiné à maintenir, pendant l'utilisation de l'élément de raccordement, une tension constante dans l'élément de raccordement, cette tension étant réglable.
16. Ensemble selon la revendication 15, caractérisé en ce que le treuil (9, 109) comporte un tambour d'enroulement (125) et un certain nombre de rouleaux de renvoi (119, 122), l'élément de raccordement (7, 107) s'étendant, au moins pendant l'utilisation, à partir du tambour d'enroulement (125) par l'intermédiaire des rouleaux de renvoi (119, 122).
17. Ensemble selon les revendications 15 et 16, caractérisé en ce que le mécanisme d'ajustement (119) comprend des rouleaux de renvoi (122) qui ont un mécanisme de pression (126) destiné à exercer une force de frottement par l'intermédiaire des rouleaux de renvoi (122) sur l'élément de raccordement (7, 107), le mécanisme de pression étant réglable de manière que, pendant l'utilisation, la tension de l'élément de raccordement soit indépendante de la quantité d'élément de raccordement enroulé sur le tambour d'enroulement.
18. Ensemble selon les revendications 15 à 17, caractérisé en ce que l'élément de raccordement (7, 107) comprend une partie en forme de joue sensiblement plate, le tambour d'enroulement (125) ayant deux flasques latéraux placés à une certaine distance correspondant approximativement à la largeur de la partie de joue.
19. Ensemble d'accouplement destiné à être utilisé dans la mise en oeuvre du procédé selon l'une quelconque des revendications 1 à 6 ou avec un

ensemble selon l'une quelconque des revendications 7 à 18, l'ensemble d'accouplement comprenant au moins un élément de raccordement (7, 107) qui peut être raccordé à un côté à l'aide d'un remorqueur, caractérisé est ce que l'élément de
5
raccordement est muni, près d'une extrémité libre, d'une partie mâle en forme de segment de sphère (128) dont la surface convexe est dirigée vers l'élément de raccordement (7, 107), la partie mâle (120, 128) pouvant être logée dans une partie femelle
10
(121) en forme de fente qui peut être raccordée fermement à une remorque à raccorder, la fente ayant une première partie (131) qui est relativement large et une seconde partie (132) qui est relativement
15
étroite et de dimension intérieure à la largeur maximale de la partie mâle (120), et la partie femelle recouvre une cavité (133), la partie mâle, dans une première position, étant mobile librement dans la
20
première partie (132) de la fente (130, 230) vers l'intérieur et l'extérieur de la cavité (133) et dans une seconde position étant retenue dans la cavité (133) par les bords de la fente (130, 230) de
25
manière que, dans la seconde position de la partie mâle (120), l'élément de fixation (7, 107) s'étend dans la fente (130, 230), la partie mâle (120) pouvant légèrement tourner à l'intérieur de la cavité (133).

tant la fente (130, 230).

- 20.** Ensemble d'accouplement selon la revendication 19, caractérisé en ce que la partie femelle (121)
30
s'étend en direction pratiquement verticale, la seconde partie (132) relativement étroite de la fente (130, 230) étant placée du côté inférieur.
- 21.** Ensemble d'accouplement selon la revendication 19 ou 20, caractérisé en ce qu'un dispositif (146, 147) est incorporé pour la libération mécanique de la partie mâle et de la partie femelle.
35
- 22.** Ensemble d'accouplement selon la revendication 21, caractérisé en ce que le dispositif de libération comprend un piston de poussé (146) de préférence commandé hydrauliquement et destiné à déplacer la partie mâle (120) de la seconde position vers la première position.
40
45
- 23.** Ensemble d'accouplement selon la revendication 22, caractérisé on ce que le dispositif de libération comprend au moins un certain nombre de parties déterminant la fente (130, 230), ces parties étant
50
disposées afin qu'elles puissent se déplacer d'une manière telle que la largeur de la fente puisse être ainsi augmentée à une valeur supérieure à la largeur animale de la partie mâle (120).
55
- 24.** Ensemble d'accouplement selon la revendication 21, caractérisé en ce que le dispositif de libération comporte au moins des parties basculantes délimi-

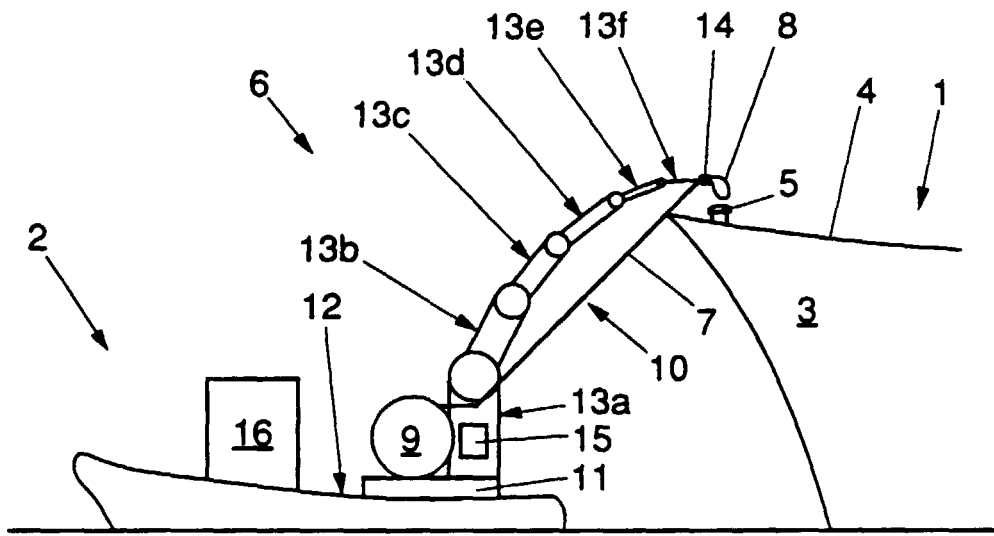

FIG. 1

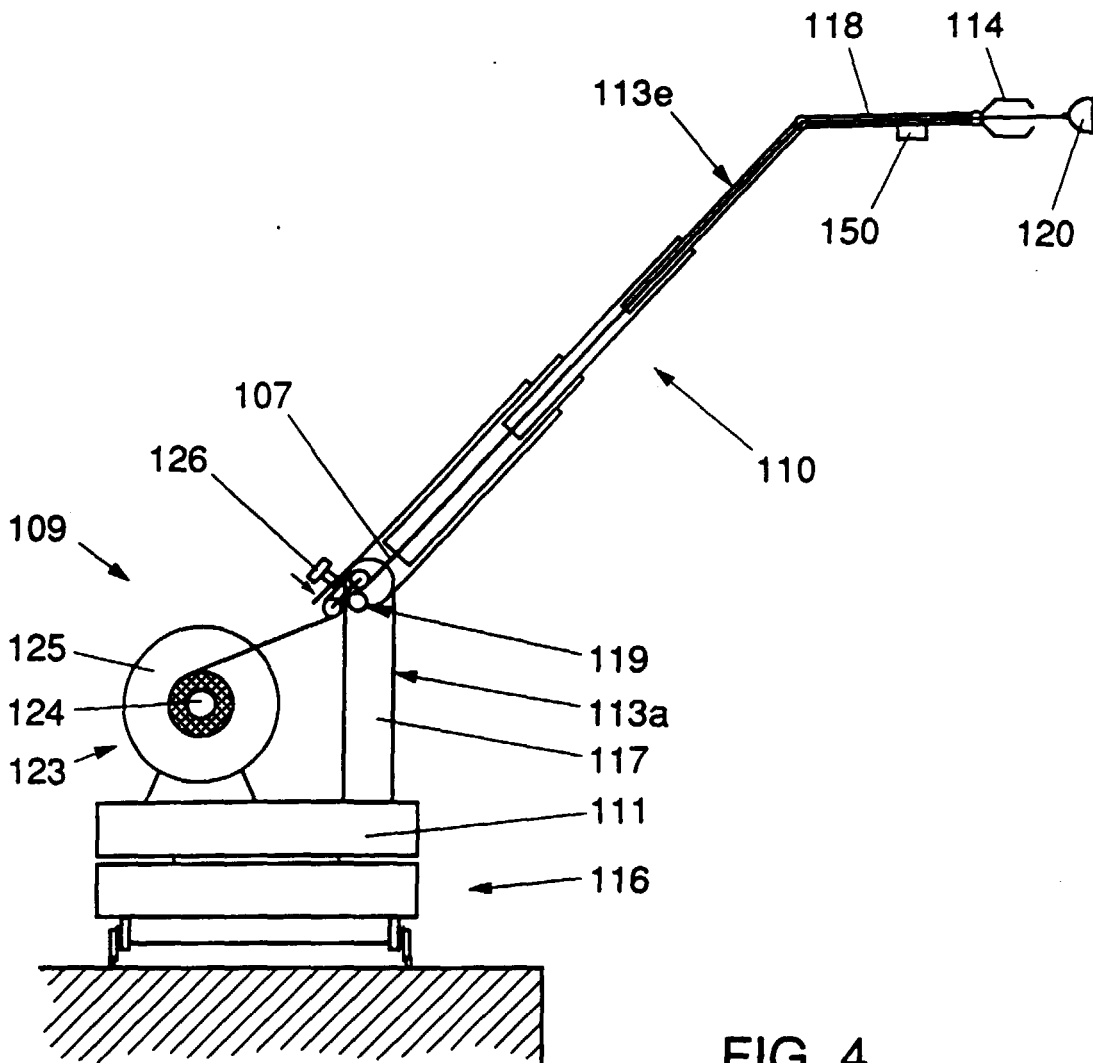

FIG. 4

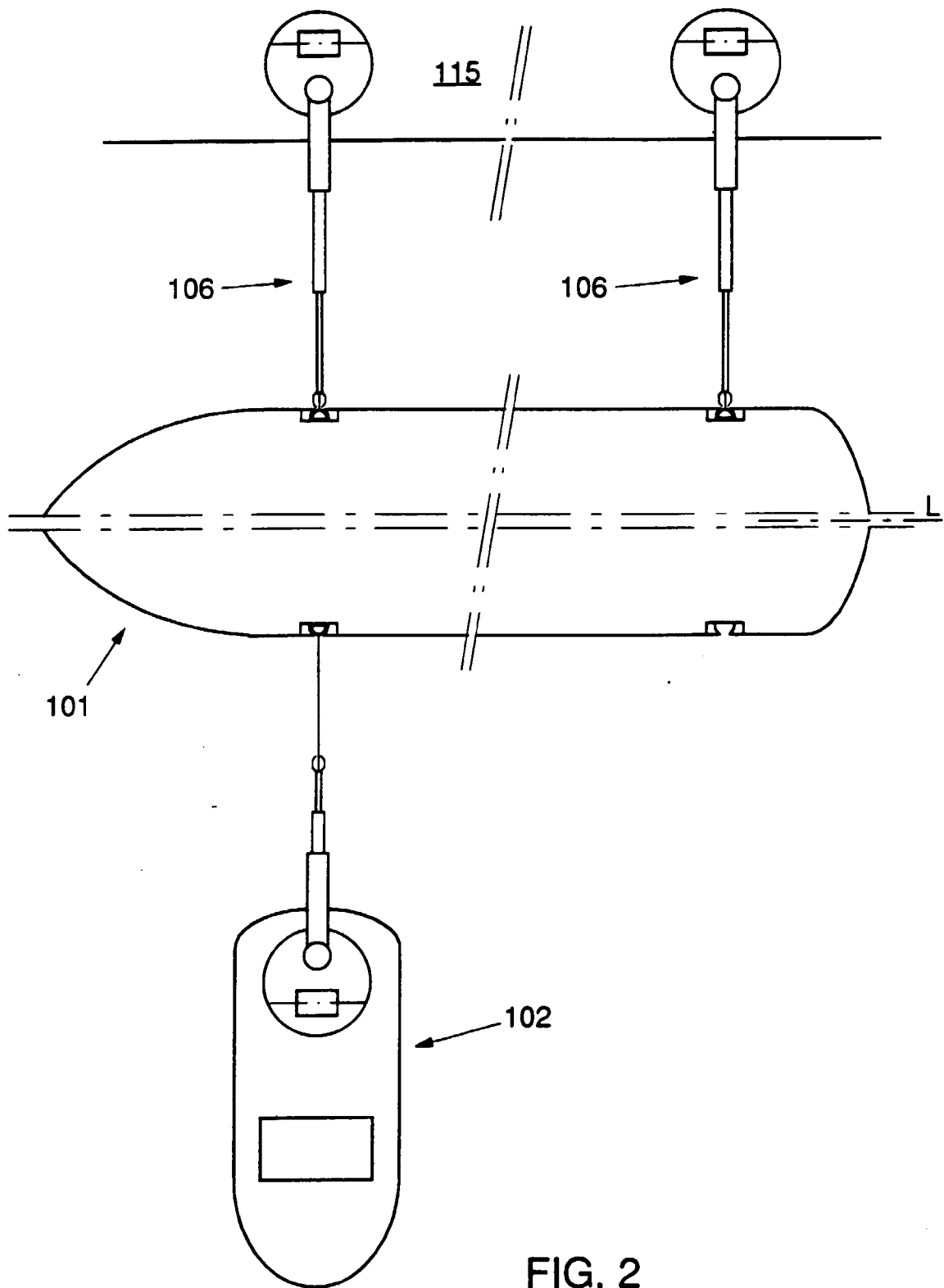

FIG. 2

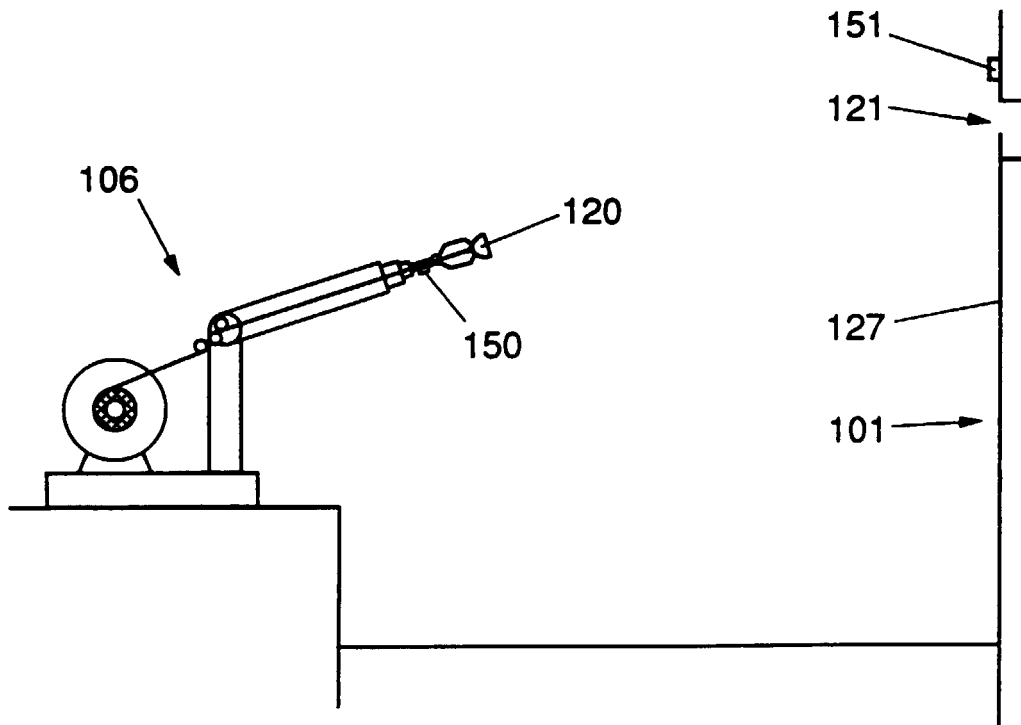

FIG. 3A

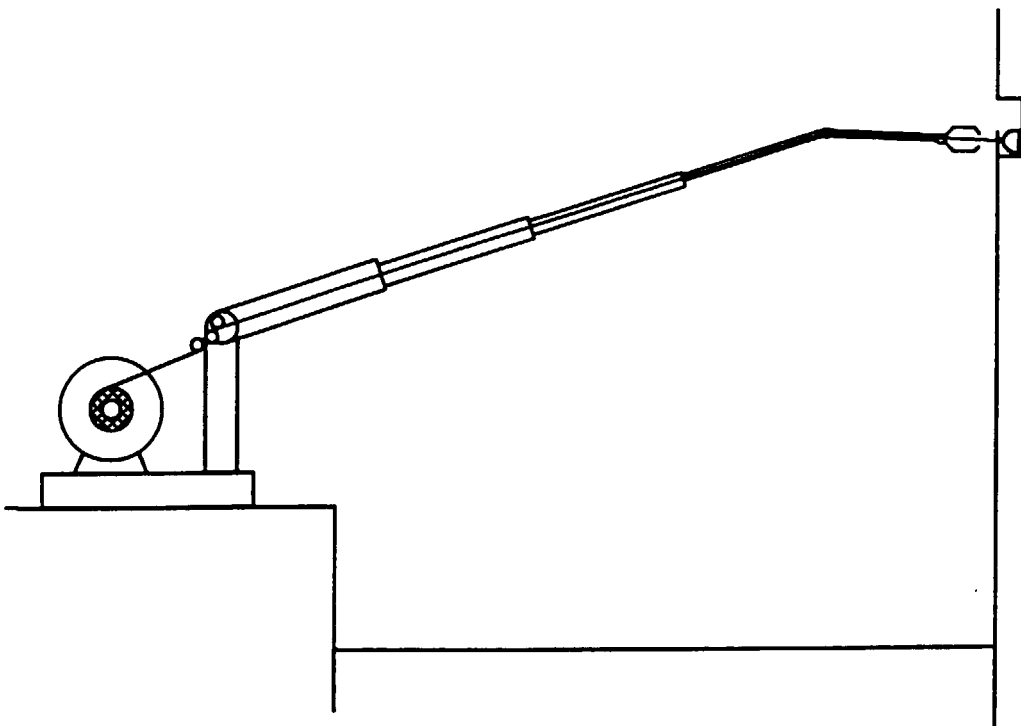

FIG. 3B

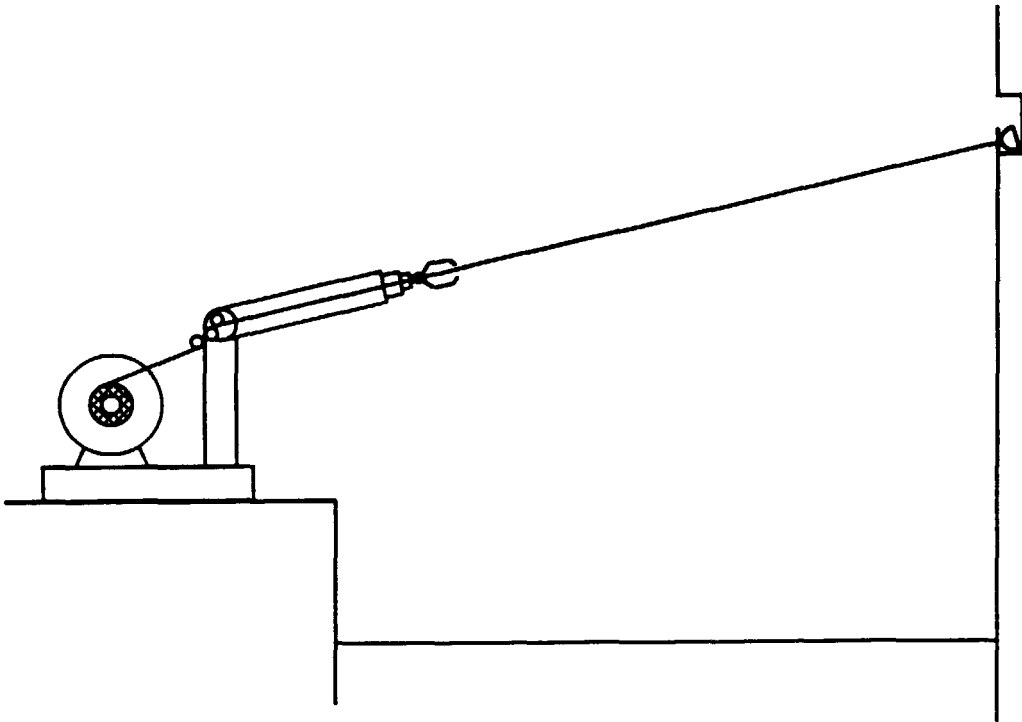

FIG. 3C

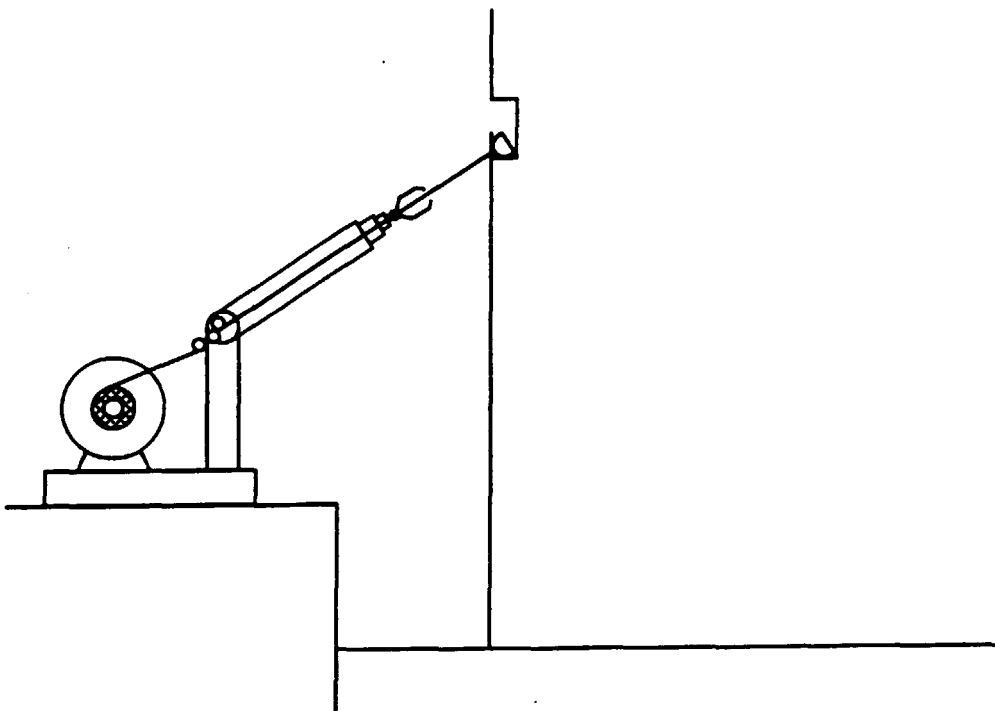

FIG. 3D

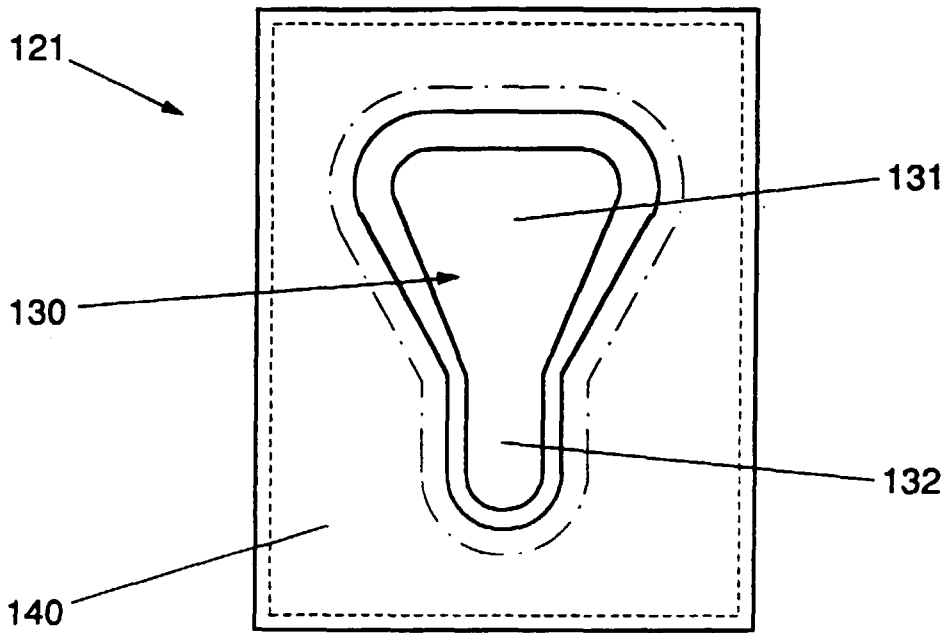

FIG. 5

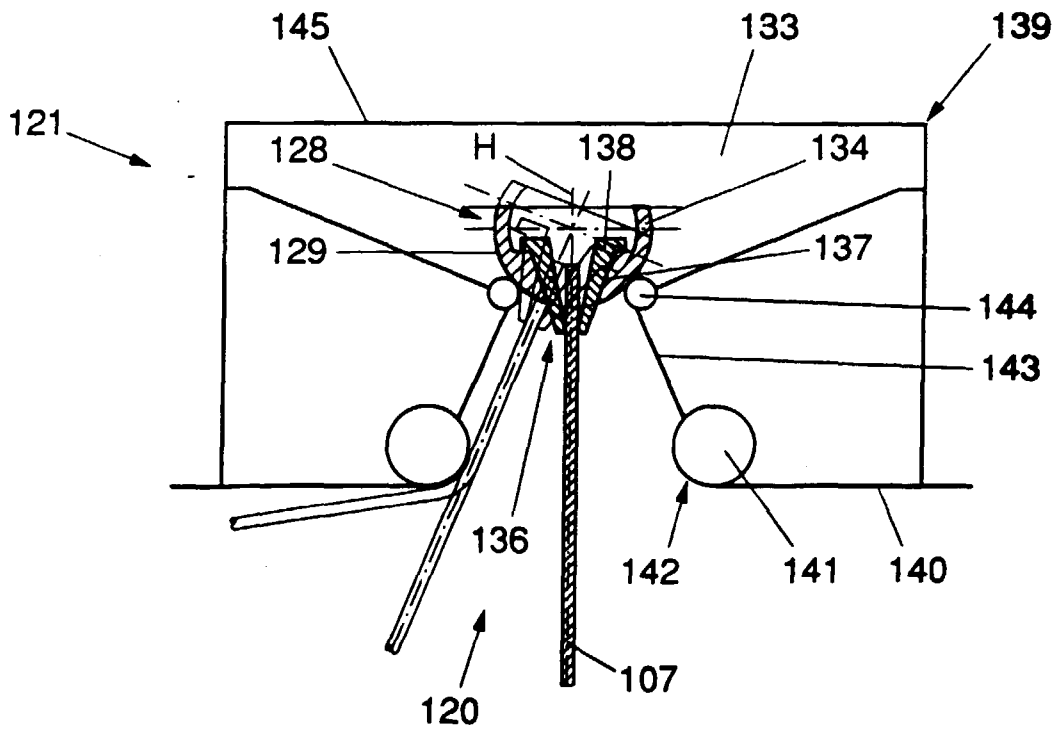

FIG. 6

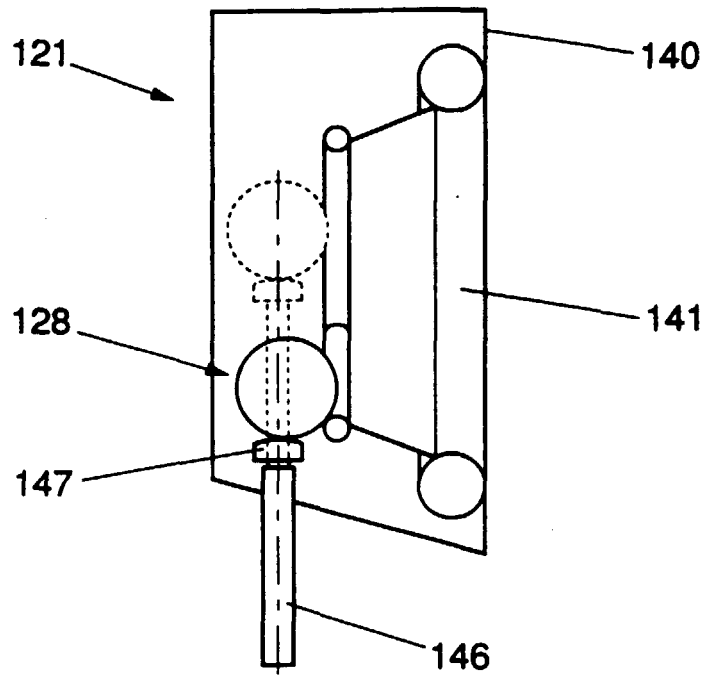

FIG. 7

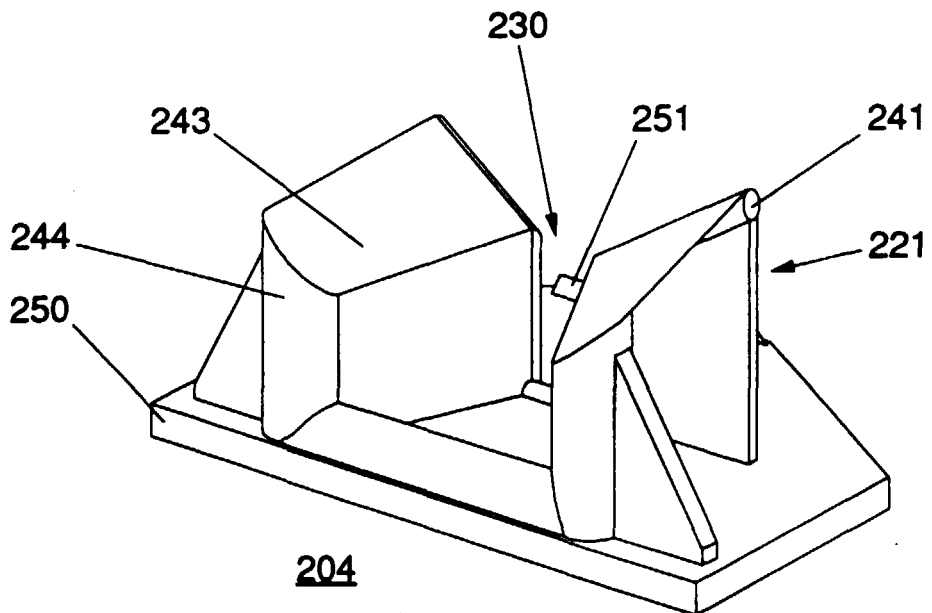

FIG. 8