

(19) World Intellectual Property  
Organization  
International Bureau



(43) International Publication Date  
29 September 2005 (29.09.2005)

PCT

(10) International Publication Number  
**WO 2005/089855 A1**

- (51) International Patent Classification<sup>7</sup>: **A61M 25/10**, A61F 2/06, A61L 27/28, 31/08
- (21) International Application Number: PCT/US2005/009310
- (22) International Filing Date: 17 March 2005 (17.03.2005)
- (25) Filing Language: English
- (26) Publication Language: English
- (30) Priority Data: 60/554,730 19 March 2004 (19.03.2004) US
- (71) Applicant (for all designated States except US): **ABBOTT LABORATORIES** [US/US]; Dept. 377 Bldg AP6A-1, 100 Abbott Park Road, Abbott Park, Illinois 60064-6008 (US).
- (72) Inventors; and
- (75) Inventors/Applicants (for US only): **TONER, John, L.** [US/US]; 817 Fair Way, Libertyville, Illinois 60048 (US). **BURKE, Sandra, E.** [US/US]; 1025 Regency Lane, Libertyville, Illinois 60048 (US). **CROMACK, Keith, R.** [US/US]; 18066 W. Banbury Drive, Gurnee, Illinois 60031 (US). **VON OEPEN, Randolph** [DE/US]; 12360 Hilltop Drive, Los Altos Hills, CA 94024 (US).
- (74) Agents: **COLEMAN-JAMES, Patricia** et al.; Dept. 377 Bldg AP6A-1, 100 Abbott Park Road, Abbott Park, Illinois 60064-6008 (US).
- (81) Designated States (unless otherwise indicated, for every kind of national protection available): AE, AG, AL, AM, AT, AU, AZ, BA, BB, BG, BR, BW, BY, BZ, CA, CH, CN, CO, CR, CU, CZ, DE, DK, DM, DZ, EC, EE, EG, ES, FI, GB, GD, GE, GH, GM, HR, HU, ID, IL, IN, IS, JP, KE, KG, KP, KR, KZ, LC, LK, LR, LS, LT, LU, LV, MA, MD, MG, MK, MN, MW, MX, MZ, NA, NI, NO, NZ, OM, PG, PH, PL, PT, RO, RU, SC, SD, SE, SG, SK, SL, SM, SY, TJ, TM, TN, TR, TT, TZ, UA, UG, US, UZ, VC, VN, YU, ZA, ZM, ZW.
- (84) Designated States (unless otherwise indicated, for every kind of regional protection available): ARIPO (BW, GH, GM, KE, LS, MW, MZ, NA, SD, SL, SZ, TZ, UG, ZM, ZW), Eurasian (AM, AZ, BY, KG, KZ, MD, RU, TJ, TM), European (AT, BE, BG, CH, CY, CZ, DE, DK, EE, ES, FI, FR, GB, GR, HU, IE, IS, IT, LT, LU, MC, NL, PL, PT, RO, SE, SI, SK, TR), OAPI (BF, BJ, CF, CG, CI, CM, GA, GN, GQ, GW, ML, MR, NE, SN, TD, TG).
- Published:**
- with international search report
  - before the expiration of the time limit for amending the claims and to be republished in the event of receipt of amendments
- For two-letter codes and other abbreviations, refer to the "Guidance Notes on Codes and Abbreviations" appearing at the beginning of each regular issue of the PCT Gazette.*



**WO 2005/089855 A1**

(54) Title: MULTIPLE DRUG DELIVERY FROM A BALLOON AND A PROSTHESIS

(57) Abstract: Disclosed is an interventional device for delivery of therapeutic agents from an angioplasty balloon and from a prosthesis such as an intraluminal stent. The invention also relates to the method of loading the beneficial agents onto the balloon and the device, as well as the method of delivery of the agents from separate surfaces. The invention also relates to an interventional device having a prosthesis surface that is loaded with a first beneficial agent, and a balloon surface loaded with a second beneficial agent. The invention also relates to a method of loading multiple beneficial agents onto the prosthesis surfaces and the balloon surfaces, and to a method of manufacturing an interventional device for the delivery of a first beneficial agent and a second beneficial agent from separate surfaces.

## MULTIPLE DRUG DELIVERY FROM A BALLOON AND A PROSTHESIS

BACKGROUND OF THE INVENTION

5

Related Application

The present invention relates to an interventional device for delivery of therapeutic agents from an angioplasty balloon and from a prosthesis such as an intraluminal stent. The invention also relates to the method of loading the beneficial agents onto the balloon and the medical device, as well as the method of delivery of the agents from separate surfaces. The invention also relates to an interventional device having a prosthesis surface that is loaded with a first beneficial agent, and a balloon surface loaded with a second beneficial agent. The invention also relates to a method of loading multiple beneficial agents onto the prosthesis surfaces and the balloon surfaces, and to a method of manufacturing an interventional device for the delivery of a first beneficial agent and a second beneficial agent from separate surfaces.

Description of Related Art

Balloon angioplasty associated with the implantation of a vascular stent is a procedure designed to expand occluded blood vessels, resulting in adequate perfusion of distal tissues. The stent, which is crimped onto the balloon, is introduced via a peripheral artery, and advanced to the lesion site over a guidewire. Inflation of the balloon results in compression of plaque and simultaneous implantation of the stent, which acts as a scaffold to keep the vessel expanded to its normal diameter. The balloon is then deflated, allowing removal of the catheter assembly, leaving the stent in place to maintain patency of the vessel.

This percutaneous intervention, described as PCI when associated with coronary balloon angioplasty, has been effective in normalizing the vessel lumen, and providing relief of pain often associated with myocardial ischemia. The procedure is not restricted to the coronary vasculature, but may also be applied to other vessels, including renal, carotid, iliac and superficial femoral arteries. However, although the success of the intervention is generally high, the long-term patency of the vessel is often reduced by restenosis of the vessel at the site of the original lesion. This restenotic process is the consequence of a variety of

factors acting in concert to re-occlude the vessel, reducing blood flow and nutrient supply to tissues. These include progression of the underlying disease, as well as the generation of cytokines and other growth factors which promote cell proliferation. These factors emanate from a variety of inflammatory cell types including monocytes and macrophages. In addition to inflammation and cell proliferation, migration of cells from the medial or adventitial layers of the vessel wall may contribute to the growth of a new layer, described as neointima, which re-occludes the vessel. In recent years, the use of bare metal stents, while effective in the short-term, has been associated with a significant rate of restenosis. Therefore, many investigators have sought to provide technologies to reduce the restenosis rate, while maintaining the beneficial effects offered by these metal scaffolds. The coating of stents with bioinert polymers has been somewhat effective, but the most important advance in this field has been the loading of these polymers with drugs known to block cell proliferation. One commonly applied technique for the local delivery of a drug is through the use of a polymeric carrier coated onto the surface of a stent, as disclosed in Berg et al., U.S. Pat. No. 5,464,650, the disclosure of which is incorporated herein by reference. Such conventional methods and products generally have been considered satisfactory for their intended purpose. The gradual elution of drug from the polymer is known to impact the restenotic process, providing beneficial concentrations of the beneficial agent at a time when the inflammatory and proliferative processes are thought to be most prevalent. The introduction of these drug-eluting stents (DES) has reduced the restenosis rate from 20 – 30% to less than 10% in several clinical trials. However, many are attempting to reduce the rate even further, providing nearly all patients who receive a DES with long-term vessel patency and minimal chance of return to the cath lab for repeat procedures. The delivery of multiple drugs, using both the stent and the balloon itself as delivery platforms, may help to achieve this goal.

As evident from the related art, conventional methods of loading interventional devices with beneficial agents, such as drugs, often requires coating the entire prosthesis with a polymer capable of releasing beneficial drugs, as disclosed in Campbell, U.S. 5,649,977 and Dinh et al., U.S. Patent No. 5,591,227, the disclosures of which are incorporated by reference.

Therefore, the present invention proposes the use of one or more beneficial agents, applied to the surface of the balloon material by any method, and the application of one or more beneficial agents applied to either the bare-metal surface of a second device, or

incorporated with the polymer which coats the second device. The delivery of the beneficial agent from the balloon is expected to occur during either pre-dilatation of the vessel at the lesion site, or from the balloon during the delivery of the device during a stenting procedure. Additionally, the delivery of the beneficial agent can be from the balloon during a final stent  
5 sizing balloon expansion. The delivery of the beneficial agent from the prosthesis is expected to occur over a longer period, as the drug is released from the polymer or from the surface of the device. The associated prosthesis may be placed directly when the balloon is inflated at the lesion site, immediately after as commonly practiced in pre-dilatation procedures, or within a suitable time period in a second interventional procedure.

10

### SUMMARY OF THE INVENTION

The purpose and advantages of the present invention will be set forth in and apparent from the description that follows, as well as will be learned by practice of the invention.

Additional advantages of the invention will be realized and attained by the methods  
15 and systems particularly pointed out in the written description and claims hereof, as well as from the appended drawings.

According to one embodiment, the present invention relates to a system for delivering a beneficial agent. The system includes a balloon having a coating loaded with a beneficial agent (such as a drug) and a prosthesis having a coating loaded with a beneficial agent (which  
20 can also be a drug that is the same or different than the beneficial agent on the balloon.) The balloon and the prosthesis can have more than one beneficial agent in the respective coatings. The coatings can be continuous over the surface of the balloon or the prosthesis or discontinuous. Numerous beneficial agents are suitable for delivery according to the invention.

According to another embodiment, the present invention relates to methods of treating  
25 and preventing a vascular disease. The inventive methods include delivery of a balloon having a coating loaded with a beneficial agent and delivery of a prosthesis having a coating loaded with a beneficial agent. The delivery of the balloon and the prosthesis to a target site can be sequential or simultaneous. The coated prosthesis can be delivered before or after the  
30 coated balloon. The beneficial agents delivered from the balloon can be the same as or different from those delivered from the stent.

According to other embodiments, the present invention relates to a method of providing a device for treatment and prevention of vascular disease, including techniques for coating the balloon with beneficial agents.

To achieve these and other advantages and in accordance with the purpose of the invention, as embodied and broadly described, the invention includes an interventional device for the delivery of multiple beneficial agents wherein the device comprises a prosthesis to be deployed in a lumen, the prosthesis having a surface; a first beneficial agent loaded on the surface of the prosthesis; and a balloon to expand the prosthesis; and a second beneficial agent loaded on the surface of the balloon.

In a further aspect of the invention, the first beneficial agent and the second beneficial agent can be incompatible with each other or detrimental to each other. The first beneficial agent can be dissolved in a first solvent and the second beneficial agent can be dissolved in a second solvent, wherein the first solvent and the second solvent are immiscible. Similarly, the first beneficial agent can react with the second beneficial agent. It is possible for the first beneficial agent to be more hydrophobic than the second beneficial agent. Also, the first beneficial agent can be loaded along a first controlled trajectory on the prosthesis and the second beneficial agent can be loaded along a second controlled trajectory on the balloon.

In a further aspect of the invention, an interventional device is provided wherein at least one of the first beneficial agent and the second beneficial agent is mixed with a binder prior to being loaded on the prosthesis or the balloon.

In accordance with another aspect of the invention, an interventional device is provided wherein the first beneficial agent is mixed with a binder having a first release rate for delivery of the first beneficial agent from the prosthesis. The second beneficial agent can be mixed with a binder having a second release rate for delivery of the second beneficial agent from the balloon; the first release rate being different than the second release rate. The first beneficial agent can be different than the second beneficial agent.

In accordance with another aspect of the invention, an interventional device is provided wherein the first beneficial agent has a first local areal density and the second beneficial agent has a second local areal density. At least one of the first local areal density and the second local areal density can be uniform across a selected portion of the prosthesis or balloon. Also, at least one of the first local areal density of beneficial agent and the second local areal density can be varied across a selected portion of the prosthesis or balloon. The

first local areal density of the first beneficial agent can be different than the second local areal density of the second beneficial agent. The interventional device can further include a third beneficial agent loaded on at least one of the first surface and second surface of the prosthesis or on the balloon.

5           In accordance with still another aspect of the invention, an interventional device is provided wherein the prosthesis further includes a layer of base material on a selected portion thereof, and the first beneficial agent is loaded to the base material layer. The base material layer defines a pattern for loading the first beneficial agent. This prosthesis is then combined with a balloon that is coated with a second beneficial agent.

10           In accordance with a further aspect of the invention, the prosthesis includes at least one cavity defined therein. The cavity can be filled with multiple beneficial agents. Preferably, the at least one cavity is at least partially loaded with a base material, and multiple beneficial agents are loaded to the base material. This prosthesis is then combined with a balloon that is coated with a second beneficial agent.

15           The invention also provides a method of loading multiple beneficial agents onto a prosthesis for delivery within a lumen wherein the method comprises the steps of providing a prosthesis to be deployed within a lumen; providing a first beneficial agent and to be loaded on the prosthesis; providing an additional beneficial agent to be loaded on the prosthesis. This prosthesis is then combined with a balloon that is coated with a second beneficial agent.

20           In accordance with a further aspect of the invention, the first beneficial agent provided by the first beneficial agent providing step is incompatible with the second beneficial agent provided by the second beneficial agent providing step. The first beneficial agent provided by the first beneficial agent providing step can be dissolved in a first solvent and the second beneficial agent provided by the second beneficial agent providing step can be dissolved in a  
25           second solvent. The first solvent and the second solvent can be immiscible. The first beneficial agent provided by the first beneficial agent providing step also can be reactive with the second beneficial agent provided by the second beneficial agent providing step. Furthermore, the dispensing steps can be performed to define an interspersed pattern of the first beneficial agent on the prosthesis and the second beneficial agent on the balloon, if  
30           desired. The dispensing steps are performed simultaneously. The dispensing steps also can be performed to define an overlapping pattern of the first beneficial agent and the second beneficial agent.

In accordance with another aspect of the invention, the method can further include the step of mixing the first beneficial agent with a binder prior to the first beneficial agent dispensing step onto the prosthesis and a step of mixing the second beneficial agent with a binder prior to the second beneficial agent dispensing step onto the balloon. In accordance with a still further aspect of the invention, the method can further include the step of mixing the first beneficial agent with a first binder having a first release rate for delivery of the first beneficial agent from the prosthesis and the second beneficial agent with a second binder having a second release rate for delivery of the second beneficial agent from the balloon. The first release rate can be different than the second release rate, and first beneficial agent can be different than the second beneficial agent.

In accordance with another aspect of the invention, a method is provided wherein the first beneficial agent dispensing step is performed to provide the first beneficial agent with a first local areal density and the second beneficial agent dispensing step is performed to provide the second beneficial agent with a second local areal density, wherein at least one of the first local areal density and the second local areal density is varied across a selected portion of the prosthesis or balloon.

In accordance with still another aspect of the invention, a method can be provided further including the step of applying a layer of base material on a selected portion of the prosthesis, and the dispensing steps are performed to introduce the first beneficial agent to the base material layer. The base material layer can be applied to define a pattern for loading the first beneficial agent. This prosthesis is then combined with a balloon that is coated with a second beneficial agent.

The invention also includes an interventional device for delivery of beneficial agent, where the beneficial agent can be selected from a group consisting of antithrombotics, anticoagulants, antiplatelet agents, anti-lipid agents, thrombolytics, antiproliferatives, anti-inflammatories, agents that inhibit hyperplasia, smooth muscle cell inhibitors, antibiotics, growth factor inhibitors, cell adhesion inhibitors, cell adhesion promoters, antimetotics, antifibrins, antioxidants, antineoplastics, agents that promote endothelial cell recovery, antiallergic substances, radiopaque agents, viral vectors, antisense compounds, oligionucleotides, cell permeation enhancers, angiogenesis agents, and combinations thereof. The prosthesis can be a stent, graft, or stent-graft. The prosthesis may also be a vascular or biliary stent or an embolic capture device. The interventional device can include an overcoat

applied to at least one of the inner surface or the outer surface of the prosthesis. The prosthesis coating or balloon coating can be applied by dip coating, spray coating, or ink jetting where the fluid-dispenser can be a drop-on-demand fluid type printer or a charge-and-deflect type print head. Additionally, the beneficial agent can be built up on the prosthesis or balloon by applying multiple layers. Furthermore, the beneficial agent can be mixed with a binder and also can be loaded onto the prosthesis with a polymer. The polymer is preferably biocompatible. For example, the polymer can be a macromolecule containing pendant phosphorylcholine groups such as poly(MPC<sub>w</sub>:LMA<sub>x</sub>:HPMA<sub>y</sub>:TSMA<sub>z</sub>), where MPC is 2 methacryloyloxyethylphosphorylcholine, LMA is lauryl methacrylate, HPMA is hydroxypropyl methacrylate and TSMA is trimethoxysilylpropyl methacrylate. The binder can be composed of complex sugars (mannitol), starches (e.g., cellulose), collagens. In general the binder would be noncrystalline, have low water solubility, have good film forming characteristics, good solubility with solvents that may be used to dissolve the drug, biocompatible, inert (nonreactive with respect to the drug and also body tissues, fluids, etc), polymer, (e.g., hydrogel), can be hydrophobic if not hydrogel, especially if it is not permanently attached to balloon (if permanently attached, then can use hydrogel, can be used to absorb drug and then when balloon inflated, will squeeze out the drug into abluminal tissue), low blood solubility if not permanently attached to balloon

In accordance with another aspect of the invention, the beneficial agents can be applied to the interventional device using a fluid jet dispenser capable of dispensing discrete droplets along a controlled trajectory, such as drop-on-demand fluid type printer or a charge-and-deflect type printer. In accordance with a further aspect of the invention, the beneficial agent can be mixed with a binder. The beneficial agent preferably is loaded onto the prosthesis with a polymer. Preferably, the polymer is a phosphorylcholine material. The second beneficial agent preferably is loaded onto the balloon with a nonpolymer film forming excipient.

In yet another aspect of the invention, the prosthesis has a tubular body when deployed, wherein the tubular body defines a longitudinal axis. The first surface of the prosthesis is defined as an inner surface of the tubular body, and the second surface of the prosthesis is defined as an outer surface of the tubular body.



In yet another aspect of the invention, the balloon is loaded with the second beneficial agent such that the delivery of the second agent extends beyond the proximal and distal ends of the prosthesis.

In yet another aspect of the invention, the balloon is loaded with the second beneficial agent such that the delivery of the second agent is delivered in a burst fashion to delivery high drug concentration locally to the tissue very rapidly, whereas the beneficial agent delivered from the prosthesis may be delivered over a longer time frame.

In further accordance with the invention, the first surface is loaded with beneficial agent selected from a group consisting of antiplatelet agents, aspirin, cell adhesion promoters, agents that promote endothelial healing, agents that promote migration and estradiol. The second beneficial agent can be selected from a group consisting of anti-inflammatories, anti-proliferatives, smooth muscle inhibitors, cell adhesion promoters, and the rapamycin analog, ABT-578, i.e., 3S,6R,7E,9R,10R,12R,14S,15E,17E,19E,21S,23S,26R,27R,34aS)-9,10,12,13,14,21,22,23,24,25,26,27,32,33,34,34a-Hexadecahydro-9,27-dihydroxy-3-[(1R)-2-[(1S,3R,4R)-3-methoxy-4-tetrazol-1-yl]cyclohexyl]-1-methylethyl]-10,21-dimethoxy-6,8,12,14,20,26-hexamethyl-23,27-epoxy-3H-pyrido[2,1-c][1,4]oxaazacyclohentricontine-1,5,11,28,29(4H,6H,31H)-pentone;23,27-Epoxy-3H-pyrido[2,1-c][1,4]oxaazacyclohentricontine-1,5,11,28,29(4H,6H,31H)-pentone.

In accordance with another aspect of the invention, an interventional device is provided wherein the first surface of the prosthesis is defined by a plurality of interconnecting structural members and prosthesis includes a first selected set of the structural members and the second surface of the prosthesis includes a second selected set of the structural members. At least one of the first selected set of structural members and the second selected set of structural members can define at least one ring-shaped element extending around a circumference of the tubular body.

The invention also provides a method of manufacturing an interventional device for the delivery of beneficial agent where the method comprises the steps of providing a prosthesis to be deployed in a lumen, the prosthesis having a first surface and a second surface; providing a first beneficial agent to be delivered from the prosthesis; providing a second beneficial agent to be delivered from the balloon; loading the first beneficial agent to at least a portion of the first surface of the prosthesis; and loading the second beneficial agent to at least a portion of the balloon.

It is to be understood that both the foregoing general description and the following detailed description are exemplary and are intended to provide further explanation of the invention claimed.

The accompanying Figures, which are incorporated in and constitute part of this specification, are included to illustrate and provide a further understanding of the method and system of the invention. Together with the description, the Figures serve to explain the principles of the invention.

#### BRIEF DESCRIPTION OF THE DRAWINGS

10 Figures 1 is a schematic representation of an angioplasty procedure and stent placement equipment showing a balloon on a catheter and the syringe systems used to inflate the balloon.

Figure 2a is a schematic representation of a stent crimped onto a catheter balloon. Figure 2b shows a blowup of the balloon and stents section of the catheter with the shading on the balloon representing a coating of a second beneficial agent and the shading of the stent struts representing a coating of a first beneficial agent.

15 Figure 3 is a schematic representation of an embodiment of the system of the present invention showing a cross section through a stent crimped onto a catheter balloon. The dark center is the catheter body, the white is the balloon, the squares are the individual struts of the stent, the shading on the balloon representing a coating of a second beneficial agent on the balloon and the shading of the stent struts representing a coating of a first beneficial agent on the stent.

20 Figure 4 is a schematic representation of the embodiment of the system of the present invention for the delivery of the beneficial agents to a vessel wall. The drawing shows the process of delivering a stent from a balloon to expand the lumen of a narrowed vessel. 4a. Shows the placement of the balloon-stent combination at the site of delivery. 4b. shows the expansion of the balloon, which results in the expansion of the stent against the vessel wall. 4c show the result after the balloon is deflated and removed leaving the stent behind.

30 Figure 5a-c is a schematic representation of a prosthesis or balloon loaded with beneficial agent having a first portion and a second portion having different local areal densities of beneficial agent in accordance with the present invention, and graph depicting corresponding areal density.

### DETAILED DESCRIPTION OF THE PREFERRED EMBODIMENTS

Reference will now be made in detail to the present preferred embodiments of the method and system for loading a first beneficial agent onto a prosthesis, and a second  
5 beneficial agent onto a balloon. Wherever possible, the same reference characters will be used throughout the drawings to refer to the same or like parts.

In accordance with the present invention, a system is provided for delivery of beneficial agents within a lumen. Particularly, the present invention provides a system including a prosthesis having a first beneficial agent and a balloon having second beneficial  
10 agent where the beneficial agents are delivered for treatment and prevention of vascular or other intraluminal diseases.

As used herein "interventional device" refers broadly to any device suitable for intraluminal delivery or implantation. For purposes of illustration and not limitation, examples of such interventional devices include stents, grafts, stent-grafts, and the like. As is  
15 known in the art, such devices may comprise one or more prostheses, each having a first cross-sectional dimension or profile for the purpose of delivery and a second cross-sectional dimension or profile after deployment. Each prosthesis may be deployed by known mechanical techniques such as balloon expansion deployment techniques, or by electrical or thermal actuation, or self-expansion deployment techniques, as well known in the art.  
20 Examples of such for purpose of illustration include U.S. Patent No. 4,733,665 to Palmaz; U.S. Patent No. 6,106,548 to Roubin et al.; U.S. Patent No. 4,580,568 to Gianturco; U.S. Patent No. 5,755,771 to Penn et al.; and U.S. Patent No. 6,033,434 to Borghi, all of which are incorporated herein by reference.

For purposes of explanation and illustration, and not limitation, an exemplary  
25 embodiment of the interventional device in accordance with the invention is shown schematically in Figure 2. In accordance with one aspect of the invention, as shown schematically in Figure 2, the interventional device generally includes a prosthesis loaded with beneficial agent to provide a local delivery of a first beneficial agent across a treatment zone and a balloon with a second beneficial agent delivered a cross a second overlapping  
30 treatment zone. Particularly, as embodied herein the prosthesis may be a stent, a graft or a stent-graft, as previously noted, for intravascular or coronary delivery and implantation. However, the prosthesis may be any type of implantable member capable of being loaded

with beneficial agent. The balloon may be any type of catheter based expandable entity that can act to expand the prosthesis, the local tissue, or push the second beneficial agent against the lumen wall.

The prosthesis can be in an expanded or unexpanded state during the loading of  
5 beneficial agent. The underlying structure of the prosthesis can be virtually any structural design and the prosthesis can be composed any suitable material such as, but not limited to, stainless steel, "MP35N," "MP20N," elastin (Nitinol), tantalum, nickel-titanium alloy, platinum-iridium alloy, gold, magnesium, polymer, ceramic, tissue, or combinations thereof. "MP35N" and "MP20N" are understood to be trade names for alloys of cobalt, nickel,  
10 chromium and molybdenum available from Standard Press Steel Co., Jenkintown, PA. "MP35N" consists of 35% cobalt, 35% nickel, 20% chromium, and 10% molybdenum. "MP20N" consists of 50% cobalt, 20% nickel, 20% chromium and 10% molybdenum. The prosthesis can be made from bioabsorbable or biostable polymers. In some embodiments, the surface of the prosthesis can include one or more reservoirs or cavities formed therein, as  
15 described further below.

The prosthesis can be fabricated utilizing any number of methods known in the art. For example, the prosthesis can be fabricated from a hollow or formed tube that is machined using lasers, electric discharge milling, chemical etching or other known techniques. Alternatively, the prosthesis can be fabricated from a sheet that is rolled into a tubular  
20 member, or formed of a wire or filament construction as known in the art.

The balloon can be in an expanded or unexpanded state during the loading of beneficial agent. Additionally, the balloon can be in a rolled or unrolled state during the loading of beneficial agent. The underlying structure of the balloon can be virtually any structural design and the balloon can be composed of any suitable material such as, but not  
25 limited to, polyester, pTFE (Teflon), nylon, Dacron, or combinations thereof. "Teflon" and "Dacron" are understood to be trade names for polymers available from DuPont Co., Wilmington, DE. In some embodiments, the surface of the balloon can include one or more reservoirs or cavities formed therein or ports for solution delivery.

The balloon can be fabricated utilizing any number of methods known in the art. For  
30 example, the balloon can be fabricated from a hollow or formed tube that is cover with thin membranes of polymer that is solution or physically (by laser or ultrasonically) welded to the tube. The inner volume of the balloon is then in direct contact with the tube such that air or

aqueous solutions can be injected into the space under pressure to expand the balloon into any predefined shape that is of use. The surface of the balloon can be rolled to reduce the outer diameter of the final catheter balloon assemble.

The balloons can be loaded with a beneficial agent from a dilute solution of the agent  
5 made in an appropriate solvent (for example Ethanol) (if desired this solution could also contain multiple beneficial agents) and allowed to dry before the stent is crimped onto it. Alternatively, the coating could not be allowed to dry or cure past a "tacky" state before the stent is crimped onto it. This would enable the adhesion of the beneficial agent coating on the balloon to the inside of the prosthesis. This process increases the retention of the  
10 prosthesis onto the balloon (acting as a prosthesis retention enhancer) thus reducing the chance that the stent will move on the angioplasty balloon during the torturous trip to the coronary arteries. To prevent the film on the balloon from drying to quickly (i.e. becoming hard before the stent was placed over the balloon) the solution can contain a second liquid that has a higher boiling point (preferable water) and thus a slower drying time than the main  
15 solvent. Additionally, the use of a two solvent system (i.e. Ethanol-water) would allow the solvent to be adjusted such that the balloons beneficial agent (for example dexamethasone) is soluble enough to be laid down but the beneficial agent (for example ABT-578, rapamycin, and rapamycin analogies) on the prosthesis is not soluble enough to leach out of the prosthesis into the balloon coating or out of the balloon coating into the prosthesis coating  
20 during the drying time. Additionally, polymer barriers, timing layers, top or capcoats, especially on the luminal side of the prosthesis, or the use of bare metal interfaces can be used to prevent drug transfer from the balloon surface into the delivery polymer of the prosthesis. Alternately, some of the beneficial agent from the balloon could be allowed to transfer to the stent creating a gradient of the two beneficial agents released from the stent  
25 into the tissue. The binder can be composed of complex sugars (mannitol), starches (e.g., cellulose), collagens. In general the binder would be noncrystalline, have low water solubility, have good film forming characteristics, good solubility with solvents that may be used to dissolve the drug, biocompatible, inert (nonreactive with respect to the drug and also body tissues, fluids, etc), polymer, (e.g., hydrogel), can be hydrophobic if not hydrogel,  
30 especially if it is not permanently attached to balloon (if permanently attached, then can use hydrogel, can be used to absorb drug and then when balloon inflated, will squeeze out the drug into abluminal tissue), low blood solubility if not permanently attached to balloon

The prosthesis, balloon combination can be fabricated utilizing any number of methods known in the art. For example, the prosthesis can be slipped over the end of the balloon and aligned at the center of the balloon. The prosthesis can be pre reduced in diameter such that as it is slipped over the end of the balloon there is a tight fit between the prosthesis and the balloon surface. Additionally, the prosthesis can be crimped onto the balloon to ensure that the prosthesis does not move during delivery of the prosthesis. The envisioned steps for this process would be: Dip or spray coat the balloon with the balloons beneficial agent, place the previously beneficial agent coated prosthesis onto a dry or tacky balloon and place Balloon/Stent into crimper and crimping.

As noted above, the prosthesis and the balloon are at least partially loaded with beneficial agent (10a, 10b, 10c). "Beneficial agent" as used herein, refers to any compound, mixture of compounds, or composition of matter consisting of a compound, which produces a beneficial or useful result. The beneficial agent can be a polymer, a marker, such as a radiopaque dye or particles, or can be a drug, including pharmaceutical and beneficial agents, or an agent including inorganic or organic drugs without limitation. The agent or drug can be in various forms such as uncharged molecules, components of molecular complexes, pharmacologically-acceptable salts such as hydrochloride, hydrobromide, sulfate, laurate, palmitate, phosphate, nitrate, borate, acetate, maleate, tartrate, oleate, and salicylate.

An agent or drug that is water insoluble can be used in a form that is a water-soluble derivative thereof to effectively serve as a solute, and on its release from the device, is converted by enzymes, hydrolyzed by body pH, or metabolic processes to a biologically active form. Additionally, the agents or drug formulations can have various known forms such as solutions, dispersions, pastes, particles, granules, emulsions, suspensions and powders. The drug or agent may or may not be mixed with polymer or a solvent as desired.

For purposes of illustration and not limitation, the drug or agent can include antithrombotics, anticoagulants, antiplatelet agents, thrombolytics, lipid-lowering agents, antiproliferatives, anti-inflammatory, agents that inhibit hyperplasia, inhibitors of smooth muscle cell proliferation, antibiotics, growth factor inhibitors, cell adhesion promoters, or cell adhesion inhibitors. Other drugs or agents include but are not limited to antineoplastics, antimitotics, antifibrins, antioxidants, agents that promote endothelial cell recovery, antiallergic substances, radiopaque agents, viral vectors, antisense compounds, oligonucleotides, cell permeation enhancers, angiogenesis agents, and combinations thereof.

Examples of such antithrombotics, anticoagulants, antiplatelet agents, and thrombolytics include unfractionated heparin, low molecular weight heparins, such as dalteparin, enoxaparin, nadroparin, reviparin, ardoparin and certaparin, heparinoids, hirudin, argatroban, forskolin, vapriprost, prostacyclin and prostacylin analogues, dextran, D-phe-pro-  
5 arg-chloromethylketone (synthetic antithrombin), dipyridamole, glycoprotein IIb/IIIa (platelet membrane receptor antagonist antibody), recombinant hirudin, and thrombin inhibitors such as Angiomax™, from Biogen, Inc., Cambridge, Mass; and thrombolytic agents, such as urokinase, e.g., Abbokinase™ from Abbott Laboratories Inc., North Chicago, IL, recombinant urokinase and pro-urokinase from Abbott Laboratories Inc., tissue plasminogen  
10 activator (Alteplase™ from Genentech, South San Francisco, CA and tenecteplase (TNK-tPA).

Examples of such cytostatic or antiproliferative agents include rapamycin and its analogs such as ABT-578, i.e.,  
3S,6R,7E,9R,10R,12R,14S,15E,17E,19E,21S,23S,26R,27R,34aS)-  
15 9,10,12,13,14,21,22,23,24,25,26,27,32,33,34,34a-Hexadecahydro-9,27-dihydroxy-3-[(1R)-2-[(1S,3R,4R)-3-methoxy-4-tetrazol-1-yl)cyclohexyl]-1-methylethyl]-10,21-dimethoxy-6,8,12,14,20,26-hexamethyl-23,27-epoxy-3H-pyrido[2,1-c][1,4]oxaazacyclohentriacontine-1,5,11,28,29(4H,6H,3 1H)-pentone;23,27-Epoxy-3H pyrido[2,1-  
20 c][1,4]oxaazacyclohentriacontine-1,5,11,28,29(4H,6H,3 1H)-pentone, everolimus, tacrolimus and pimecrolimus, angiopeptin, angiotensin converting enzyme inhibitors such as captopril, e.g. Capoten® and Capozide® from Bristol-Myers Squibb Co., Stamford, Conn., cilazapril or lisinopril, e.g., Prinivil® and Prinzide® from Merck & Co., Inc., Whitehouse Station, NJ; calcium channel blockers such as nifedipine, amlodipine, cilnidipine, lercanidipine, benidipine, trifluperazine, diltiazem and verapamil, fibroblast growth factor antagonists, fish  
25 oil (omega 3-fatty acid), histamine antagonists, lovastatin, e.g. Mevacor® from Merck & Co., Inc., Whitehouse Station, NJ. In addition, topoisomerase inhibitors such as etoposide and topotecan, as well as antiestrogens such as tamoxifen may be used.

Examples of such anti-inflammatories include colchicine and glucocorticoids such as betamethasone, cortisone, dexamethasone, budesonide, prednisolone, methylprednisolone  
30 and hydrocortisone. Non-steroidal anti-inflammatory agents include flurbiprofen, ibuprofen, ketoprofen, fenoprofen, naproxen, diclofenac, diflunisal, acetaminophen, indomethacin, sulindac, etodolac, diclofenac, ketorolac, meclofenamic acid, piroxicam and phenylbutazone.

Examples of such antineoplastics include alkylating agents such as altretamine, bendamucine, carboplatin, carmustine, cisplatin, cyclophosphamide, fotemustine, ifosfamide, lomustine, nimustine, prednimustine, and treosulfon, antimetabolites such as vincristine, vinblastine, paclitaxel, e.g., TAXOL® by Bristol-Myers Squibb Co., Stamford, Conn., docetaxel, e.g., Taxotere® from Aventis S.A., Frankfurt, Germany, antimetabolites such as methotrexate, mercaptopurine, pentostatin, trimetrexate, gemcitabine, azathioprine, and fluorouracil, and antibiotics such as doxorubicin hydrochloride, e.g., Adriamycin® from Pharmacia & Upjohn, Peapack, NJ, and mitomycin, e.g., Mutamycin® from Bristol-Myers Squibb Co., Stamford, Conn, agents that promote endothelial cell recovery such as Estradiol

Additional drugs which may be utilized in this application include inhibitors of tyrosine kinase such as RPR-101511A, PPAR-alpha agonists such as Tricor™ (fenofibrate) from Abbott Laboratories Inc., North Chicago, IL, PPAR-gamma agonists selected from a group consisting of rosiglitazone (Glaxo Smith Kline) and Pioglitazone (Takeda), HMG CoA reductase inhibitors selected from a group consisting of lovastatin, atorvastatin, simvastatin, pravastatin, cerivastatin and fluvastatin, endothelin receptor antagonists such as ABT-627 having general formula  $C_{29}H_{38}N_2O_6 \cdot ClH$ , and the following structural formula

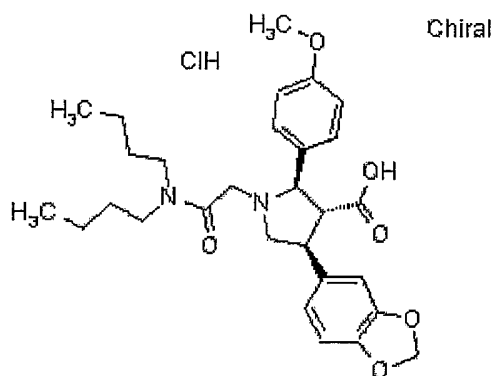

from Abbott Laboratories Inc., North Chicago, IL; matrix metalloproteinase inhibitors such as ABT-518 having general formula  $C_{21}H_{22}F_3NO_8S$  and having the following structural formula

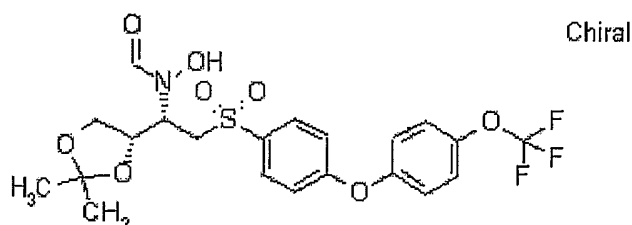



from Abbott Laboratories Inc., North Chicago, IL, antiallergic agents such as permirrolast potassium nitroprusside, phosphodiesterase inhibitors, prostaglandin inhibitors, suramin, serotonin blockers, steroids, thioprotease inhibitors, triazolopyrimidine, and nitric oxide.

5 While the foregoing beneficial agents are known for their preventive and treatment properties, the substances or agents are provided by way of example and are not meant to be limiting. Further, other beneficial agents that are currently available or may be developed are equally applicable for use with the present invention.

10 If desired or necessary, the beneficial agent can include a binder to carry, load, or allow sustained release of an agent, such as but not limited to a suitable polymer or similar carrier. The term "polymer" is intended to include a product of a polymerization reaction inclusive of homopolymers, copolymers, terpolymers, etc., whether natural or synthetic, including random, alternating, block, graft, branched, cross-linked, blends, compositions of blends and variations thereof. The polymer may be in true solution, saturated, or suspended  
15 as particles or supersaturated in the beneficial agent. The polymer can be biocompatible, or biodegradable.

For purpose of illustration and not limitation, the polymeric material include phosphorylcholine linked macromolecules, such as a macromolecule containing pendant phosphorylcholine groups such as poly(MPC<sub>w</sub>:LMA<sub>x</sub>:HPMA<sub>y</sub>:TSMA<sub>z</sub>), where MPC is 2-  
20 methacryloyloxyethylphosphorylcholine, LMA is lauryl methacrylate, HPMA is hydroxypropyl methacrylate and TSMA is trimethoxysilylpropyl methacrylate, polycaprolactone, poly-D,L-lactic acid, poly-L-lactic acid, poly(lactide-co-glycolide), poly(hydroxybutyrate), poly(hydroxybutyrate-co-valerate), polydioxanone, polyorthoester, polyanhydride, poly(glycolic acid), poly(glycolic acid-co-trimethylene carbonate),  
25 polyphosphoester, polyphosphoester urethane, poly(amino acids), cyanoacrylates, poly(trimethylene carbonate), poly(iminocarbonate), polyalkylene oxalates, polyphosphazenes, polyiminocarbonates, and aliphatic polycarbonates, fibrin, fibrinogen, cellulose, starch, collagen, Parylene®, Parylast®, polyurethane including polycarbonate urethanes, polyethylene, polyethylene terephthalate, ethylene vinyl acetate, ethylene vinyl  
30 alcohol, silicone including polysiloxanes and substituted polysiloxanes, polyethylene oxide, polybutylene terephthalate-co-PEG, PCL-co-PEG, PLA-co-PEG, polyacrylates, polyvinyl pyrrolidone, polyacrylamide, and combinations thereof. Non-limiting examples of other

suitable polymers include thermoplastic elastomers in general, polyolefin elastomers, EPDM rubbers and polyamide elastomers, and biostable plastic material such as acrylic polymers, and its derivatives, nylon, polyesters and epoxies. Preferably, the polymer contains pendant phosphoryl groups as disclosed in U.S. Patent Nos. 5,705,583 and 6,090,901 to Bowers et al. and U.S. Patent No. 6,083,257 to Taylor et al., which are all incorporated herein by reference.

The beneficial agent can include a solvent. The solvent can be any single solvent or a combination of solvents. For purpose of illustration and not limitation, examples of suitable solvents include water, aliphatic hydrocarbons, aromatic hydrocarbons, alcohols, ketones, dimethyl sulfoxide, tetrahydrofuran, dihydrofuran, dimethylacetamide, acetates, and combinations thereof. Preferably, the solvent is ethanol. More preferably, the solvent is isobutanol. Additionally, in another aspect of the invention, multiple beneficial agents are dissolved or dispersed in the same solvent. For purpose of illustration and not for limitation, dexamethasone, estradiol, and paclitaxel are dissolved in isobutanol. Alternatively, dexamethasone, estradiol, and paclitaxel are dissolved in ethanol. In yet another example, dexamethasone, estradiol, and ABT-578, i.e., the rapamycin analog,

3S,6R,7E,9R,10R,12R,14S,15E,17E,19E,21S,23-S,26R,27R,34aS)9,10,12,13,14,21,22,23,24,25,26,27,32,33,34,34a-Hexadecahydro-9,27-dihydroxy-3-[(1R)-2-[(1S,3R,4R)-3-methoxy-4-tetrazol-1-yl]cyclohexyl]-1-methylethyl]-10,21-dimethoxy-6,8,12,14,20,26-hexamethyl-23,27-epoxy-3H-pyrido[2,1-c][1,4]oxaazacyclohentriacontine -1,5,11,28,29(4H,6H,31H)-pentone; 23,27-Epoxy-3H-pyrido[2,1-c][1,4]oxaazacyclohentriacontine-1,5,11,28,29(4H,6H,31H)-pentone, are dissolved together in one solvent. Preferably, the solvent is ethanol. More preferably, the solvent is isobutanol.

Additionally, the beneficial agent includes any of the aforementioned drugs, agents, polymers, and solvents either alone or in combination.

A number of methods can be used to load the beneficial agent onto the surface of the prosthesis or balloon to provide for a controlled local areal density of beneficial agent. For example, the prosthesis or balloon can be constructed to include pores or reservoirs which are impregnated or filled with beneficial agent or multiple beneficial agents. The pores can be sized or spaced apart to correspond to or limit the amount of beneficial agent contained therein in accordance with the desired local areal density pattern along the length of the interventional device, wherein larger pores or more dense spacing would be provided in such portions intended to have a greater local areal density. Alternatively, uniform pores sizes can

be provided but the amount of beneficial agent loaded therein is limited accordingly. Additionally, if desired, a membrane of biocompatible material can then be applied over the pores or reservoirs for sustained or controlled release of the beneficial agent from the pores or reservoirs.

5           According to some of the embodiments, the beneficial agent can be loaded directly onto the prosthesis or balloon or alternatively, the beneficial agent is loaded onto a base material layer that is applied to a surface of the prosthesis or balloon. For example and not limitation, a base coating, such as a binder or suitable polymer, is applied to a selected surface of the prosthesis or balloon such that a desired pattern is formed on the prosthesis or  
10 balloon surface. Beneficial agent is then applied directly to the pattern of the base material.

          In one aspect of the invention, the desired pattern corresponds to the desired controlled local areal density. For example, a greater amount of base material layer is applied to portions of the prosthesis or balloon intended to have a greater local areal density of beneficial agent, and a lesser amount of base material is applied to portions of the prosthesis  
15 or balloon intended to have a lower local areal density of beneficial agent.

          Alternatively, a suitable base coating capable of retaining beneficial agent therein can be applied uniformly over the surface of the prosthesis or balloon, and then selected portions of the base coating can be loaded with the beneficial agent in accordance with the invention. A greater amount of beneficial agent would be loaded over a unit surface area of the base  
20 coating intended to have a greater local areal density and a lower amount of beneficial agent would be loaded over a unit surface area intended to have a lower local areal density.

          In yet another embodiment of the present invention, the beneficial agent can be applied directly to the surface of the prosthesis or balloon. Generally a binder or similar component can be required to ensure sufficient adhesion. For example, this coating  
25 technique can include admixing the beneficial agent with a suitable binder or polymer to form a coating mixture, which is then coated onto the surface of the prosthesis or balloon. The coating mixture is prepared in higher or lower concentrations of beneficial agent as desired, and then applied to selected portions of the prosthesis or balloon appropriately. In general the binder used with the beneficial agent for the prosthesis may be different than the binder  
30 used for the beneficial agent for the balloon.

In any of the embodiments disclosed herein, a porous or biodegradable membrane or layer made of biocompatible material can be coated over the beneficial agent for sustained release thereof, if desired.

5 Conventional coating techniques can be utilized to coat the beneficial agent onto the surface of the prosthesis or balloon such as spraying, dipping or sputtering and still provide the desired effect if performed appropriately. With such techniques, it may be desirable or necessary to use known masking or extraction techniques to control the location and amount in which beneficial agent is loaded. Although not required, prior to coating the prosthesis or balloon with beneficial agent, optical machine vision inspection of the prosthesis or balloon  
10 may be utilized to ensure that no mechanical defects exist. Defective prostheses or balloons may be rejected before wasting beneficial agent, some of which may be very costly.

In accordance with one aspect of the invention, a method of loading beneficial agent onto a prosthesis for delivery within a lumen is disclosed. The method comprises the steps of providing a prosthesis, beneficial agent to be delivered from the prosthesis, and a fluid-  
15 dispenser having a dispensing element capable of dispensing the beneficial agent in discrete droplets, wherein each droplet has a controlled trajectory. The method further includes creating relative movement between the dispensing element and the prosthesis to define a dispensing path and selectively dispensing the beneficial agent in a raster format to a predetermined portion of the prosthesis along the dispensing path. In particular, the  
20 beneficial agent is selectively dispensed from the dispensing element to a predetermined portion of the prosthesis in a raster format along a dispensing path. As used herein "raster format" refers to a continuous or non-continuous dispensing pattern of droplets of beneficial agent.

According to another aspect of the invention, the method of loading beneficial agent  
25 onto the prosthesis includes providing a prosthesis including a tubular member having a central axis defined along a length of the tubular member. This method further includes dispensing beneficial agent

In accordance with another aspect of the invention, additional beneficial agents or multiple beneficial agents can be loaded onto the prosthesis as described above. Therefore,  
30 further in accordance with the invention, an interventional device comprising a prosthesis loaded with a beneficial agent and additional beneficial agents is provided.

Particularly, the method described in detail above for one beneficial agent can be modified to allow for loading multiple beneficial agents onto a prosthesis and/or a balloon, which might ordinarily lead to undesirable results when using conventional loading techniques. For example and not limitation, the first beneficial agent and the second beneficial agent may have different physical and/or chemical characteristics preventing the beneficial agents from being capable of dissolving in the same solvent, or at the same pH or temperature. In particular, the first beneficial agent can be dissolved in a solvent that is immiscible with the solvent in which the second beneficial agent is dissolved. Alternatively, the first beneficial agent and the second beneficial agent may be incompatible with each other. In particular, the first beneficial agent and the second beneficial agent can be undesirably chemically reactive or may have undesirably different release rates (or contrarily, undesirably similar release rates). Additionally, the first and second beneficial agents can simply be detrimental to each other, e.g., one of the beneficial agents may degrade the efficacy of the other beneficial agent. Thus, although loading the particular multiple beneficial agents onto the same surface of a prosthesis or balloon can be desired it often may be problematic due to some incompatibility when using a conventional loading technique. In accordance with the present invention, a method of loading such beneficial agents and an interventional device that combine a prosthesis and a balloon for the delivery of such beneficial agents is provided.

As noted above, the beneficial agent can include a drug and polymer mixture. In accordance with the method of the invention, the first and second beneficial agents can correspond to drug-polymer mixtures having different concentrations of polymer to effect different release rates of the particular drug in each beneficial agent. For example, the drug-polymer mixture having a higher concentration of polymer would have a slower release of the drug within the lumen than a drug-polymer mixture having a lower concentration. Alternatively, rather than providing drug-polymer mixtures having different polymer concentrations to provide different release rates, it is also possible to dispense beneficial agents using different polymers or other binders, wherein the specific polymer or binder has different diffusivity or affinity to assure delivery of the beneficial agents at different rates. Thus, in accordance with the invention, multiple beneficial agents can be released at rates appropriate for their activities, such that the prosthesis-balloon combination of the invention

has multiple beneficial agents which elute off the prosthesis-balloon combination at desired rates.

For example, a cationic phosphorylcholine-linked polymer which has a higher affinity for anionic beneficial agents can be blended and dispersed as a first beneficial agent and lipophilic phosphorylcholine-linked polymer can be blended with lipophilic drugs as the second beneficial agent to effect different release rates respectively.

In yet another embodiment of the invention, one of the first and second beneficial agents loaded onto the prosthesis-balloon combination may be more hydrophobic than the other. Thus, in accordance with the invention is provided a prosthesis-balloon combination including first and second beneficial agents wherein one of the beneficial agents is more hydrophobic than the other. In this manner, the less hydrophobic beneficial agent is separated from the more hydrophobic beneficial agent, thereby not modifying the release rate of the more hydrophobic beneficial agent. For example and not limitation, the less hydrophobic beneficial agent may be ABT 620 {1-Methyl-N-(3,4,5-trimethoxyphenyl)-1H-indole-5-sulfonamide}, which is disclosed in US Patent No. 6,521,658, the disclosure of which is incorporated herein by reference; ABT 627, which is disclosed in US Patent No. 5,767, 144, the disclosure of which is incorporated herein by reference; ABT 518 {[S - (R\*,R\*)]-N-[1-(2,2-dimethyl-1,3-dioxol-4-yl)-2-[[4-[4-(trifluoro-methoxy)-phenoxy]phenyl]sulfonyl]ethyl]-N-hydroxyformamide }, which is disclosed in US Patent No. 6,235,786, the disclosure of which is incorporated herein by reference; dexamethasone, and the like and the more hydrophobic beneficial agent may be Fenofibrate, Tricor™ or the rapamycin analog, ABT-578, i.e., 3S,6R,7E,9R,10R,12R,14S,15E,17E,19E,21S,23S,26R,27R,34aS)-9,10,12,13,14,21,22,23,24,25,26,27,32,33,34,34a-Hexadecahydro-9,27-dihydroxy-3-[(1R)-2-[(1S,3R,4R)-3-methoxy-4-tetrazol-1-yl]cyclohexyl]-1-methylethyl]-10,21-dimethoxy-6,8,12,14,20,26-hexamethyl-23,27-epoxy-3H-pyrido[2,1-c][1,4]oxaazacyclohentacontine-1,5,11,28,29(4H,6H,31H)-pentone; 23,27-Epoxy-3H-pyrido[2,1-c][1,4]oxaazacyclohentacontine-1,5,11,28,29(4H,6H,31H)-pentone, which is disclosed in US Patent No. 6,015,815, US Patent No. 6,329,386, WO 02/123505, and WO 03/129215, disclosures of which are incorporated herein by reference thereto.

Further in accordance with the invention, using the method and systems described above, a first beneficial agent loaded onto the prosthesis can have a first local areal density and a second beneficial agent loaded onto the balloon can have a second local areal density.

As used herein, "areal density" refers to the amount of beneficial agent per unit surface area of a selected portion of the prosthesis or balloon. "Local areal density" refers to the dosage of beneficial agent per local surface area of the prosthesis or balloon. The local areal density of the first beneficial agent and the local areal density of the second beneficial agent can be  
5 uniform across each respective portion to define stepped changes in local area density as depicted in Figure 5b or can be varied across a selected portion of the prosthesis or balloon to define gradients of local area density, as depicted in Figure 5c. Accordingly, an interventional device is provided having a prosthesis or balloon that is at least partially loaded with beneficial agent having a local areal density that is varied along a selected portion of the  
10 body of the prosthesis or balloon.

In another embodiment of the invention, the local areal density is varied as a continuous gradient along a selected portion of the prosthesis or balloon as shown in Fig. 5c. Accordingly, in one aspect of the invention the local areal density of beneficial agent is varied such as to provide a prosthesis or balloon having a local areal density of beneficial  
15 agent at the ends of the prosthesis or balloon that is different than the local areal density of beneficial agent at an intermediate section of the prosthesis or balloon. For purpose of illustration and not limitation, the local areal density of beneficial agent at the intermediate section of the prosthesis can be greater than that at the proximal and distal ends of the prosthesis as shown in Figure 5c. Alternatively, the proximal and distal ends of the  
20 prosthesis can have a greater local areal density of beneficial agent than that on the intermediate section of the prosthesis. In a preferred embodiment of the invention, the varied local areal density of beneficial agent corresponds to the location of a lesion when the prosthesis is deployed within a lumen. For example, the prosthesis or balloon can be loaded to have a greater local areal density of beneficial agent along a preselected portion of the  
25 prosthesis or balloon that corresponds to the location of the lesion when the prosthesis is deployed in a lumen. Thus, targeted therapy may be achieved with the interventional device of the present invention.

As noted above, the beneficial agent is at least partially loaded onto a surface of the prosthesis. Further in accordance with the invention the prosthesis includes a first surface  
30 and a second surface that are at least partially loaded with beneficial agent. In one embodiment of the invention, the first surface and the second surface each correspond to one of the inner surface and the outer surface of the prosthesis. Thus, according to this particular

embodiment, beneficial agent, as defined above, is loaded onto the inner or luminal surface of a prosthesis as well as the outer surface of the prosthesis. In this aspect of the invention, the interventional device can be designed to provide combination therapy of beneficial agents to targeted locations. For example and not limitation, the particular beneficial agent loaded on the balloon can be intended for systemic or down stream release, whereas the particular beneficial agent loaded onto the surface of the prosthesis is intended for release into the wall of the vessel. In accordance with one aspect of the invention, the beneficial agents loaded onto the balloon include, without limitation, antiplatelet agents, aspirin, cell adhesion promoters, agents that promote endothelial recovery, agents that promote migration, estradiol, anti-inflammatories, anti-proliferatives, smooth muscle inhibitors, cell adhesion promoters, and the rapamycin analog ABT-578, i.e.,

3S,6R,7E,9R,10R,12R,14S,15E,17E,19E,21S,23S,26R,27R,34aS)-  
9,10,12,13,14,21,22,23,24,25,26,27,32,33,34,34a-Hexadecahydro-9,27-dihydroxy-3-[(1R)-2-  
[(1S,3R,4R)-3-methoxy-4-tetrazol-1-yl)cyclohexyl]-1-methylethyl]-10,21-dimethoxy-  
6,8,12,14,20,26-hexamethyl-23,27-epoxy-3H-pyrido[2,1-c][1,4]oxaazacyclohentriacontine-  
1,5,11,28,29(4H,6H,31H)-pentone; 23,27-Epoxy-3H-pyrido[2,1-  
c][1,4]oxaazacyclohentriacontine-1,5,11,28,29(4H,6H,31H)-pentone. The beneficial agents loaded onto the prosthesis include without limitation, antiplatelet agents, aspirin, cell adhesion promoters, agents that promote endothelial recovery, agents that promote migration, estradiol, anti-inflammatories, anti-proliferatives, smooth muscle inhibitors, cell adhesion promoters, angiotensin II receptor antagonists such as losartan, eposartan, valsartan and candesartan, antihypertensive agents such as carvedilol, and the rapamycin analog ABT-578, i.e., 3S,6R,7E,9R,10R,12R,14S,15E,17E,19E,21S,23S,26R,27R,34aS)-  
9,10,12,13,14,21,22,23,24,25,26,27,32,33,34,34a-Hexadecahydro-9,27-dihydroxy-3-[(1R)-2-  
[(1S,3R,4R)-3-methoxy-4-tetrazol-1-yl)cyclohexyl]-1-methylethyl]-10,21-dimethoxy-  
6,8,12,14,20,26-hexamethyl-23,27-epoxy-3H-pyrido[2,1-c][1,4]oxaazacyclohentriacontine-  
1,5,11,28,29(4H,6H,31H)-pentone; 23,27-Epoxy-3H-pyrido[2,1-  
c][1,4]oxaazacyclohentriacontine-1,5,11,28,29(4H,6H,31H)-pentone.

As noted above, the beneficial agent is loaded onto the prosthesis to provide a controlled local areal density across a length of the interventional device. That is, it may be desirable to provide a greater concentration of beneficial agent at one portion of a prosthesis and a lower concentration, or perhaps no beneficial agent, at another portion of the prosthesis.



For example, in one preferred embodiment, a greater local areal density can be provided at a first portion, *e.g.*, intermediate portion 10b, of a prosthesis or balloon 10, as shown in Fig. 5a, while providing a lower local areal density of beneficial agent to a second portion, *e.g.*, one or both end portions (10a, 10c), of the prosthesis or balloon 10. In accordance with the  
5 present invention, each of the first and second portions of the prosthesis or balloon may be defined by any of a variety of patterns or selected portions of the prosthesis or balloon. For example, the first portion of the prosthesis can be defined by longitudinal connectors whereas the second portion of the prosthesis is defined by annular rings, or vice versa.

Alternatively, the beneficial agent distribution profile for the interventional device  
10 may be controlled to include any of a variety of desired patterns. For example, the prosthesis or balloon can have a decreased local areal density of beneficial agent on the distal and proximal ends, as noted above. This profile is highly desirable in preventing adverse dosing of beneficial agent if multiple prostheses are placed in combination with each other (for example overlapping prostheses or kissing prostheses at bifurcations) but still provides for  
15 decreased dosage of the extreme ends of the interventional device as a whole. Alternatively, as embodied herein, the beneficial agent distribution profile can provide a controlled local areal density that is uniform along the length of a first prosthesis and a second prosthesis in combination, or multiple prostheses in combination. Alternatively, in accordance with the invention, the beneficial agent distribution profile provides a controlled local areal density  
20 that is varied along the length of the first prosthesis and the second prosthesis in combination, or multiple prostheses in combination.

Another feature of the present invention includes applying a layer of base material on a selected portion of the prosthesis or balloon described above. The beneficial agent is loaded onto the base material layer according to the methods described above. The base  
25 material layer preferably defines a pattern for loading the beneficial agent onto the prosthesis or balloon.

The present invention also encompasses, for any of the embodiments disclosed, the application of a rate-controlling topcoat over the beneficial agent loaded prosthesis, balloon, or prosthesis-balloon combination for further controlling or sustaining the release of  
30 beneficial agent. The rate-controlling topcoat may be added by applying a coating layer posited over the beneficial agent loaded prosthesis, balloon, or prosthesis-balloon combination. The thickness of the layer is selected to provide such control. Preferably, the

overcoat is applied by spray coating or fluid-jet technology. Advantageously, fluid jetting an overcoat such as a polymer overcoat allows thinner and more uniform layers. However other conventional methods can be used such as other fluid-dispensers, vapor deposition, plasma deposition, spraying, or dipping, or any other coating technique known in the art.

5           The present invention also encompasses, for any of the embodiments disclosed, the application of polymer barriers, timing layers, top or capcoats, especially on the luminal side of the prosthesis, or the use of bare metal interfaces to be used to prevent drug transfer from the balloon surface into the delivery polymer of the prosthesis. Alternately, some of the beneficial agent from the balloon could be allowed to transfer to the stent creating a gradient  
10 of the two beneficial agents released from the stent into the tissue.

          The present invention also provides a method for manufacturing an interventional device for delivery of beneficial agents. This method comprises the steps of providing a prosthesis to be deployed within a lumen; providing a balloon configured to be deployed in an overlapping relationship with the prosthesis, the prosthesis and the balloon in combination  
15 defining at least an overlapping segment; and loading the prosthesis with a first beneficial agent and the balloon with a second beneficial agent to provide a controlled local areal density along a length of the prosthesis and the balloon in combination. The method described in detail above is preferred for such loading step.

          The present invention also provides a method of delivering beneficial agents. In  
20 accordance with this method, as described in detail in conjunction with the description of the interventional device of the present invention above, the method comprising the steps of providing a prosthesis having a tubular body when deployed in a lumen; providing a balloon capable of expanding in the lumen; loading the prosthesis with a first beneficial agent and the balloon with a second beneficial agent; deploying the prosthesis into a lumen with the  
25 beneficial agent coated balloon deploying the beneficial agent coated prosthesis into the lumen to define in combination at least one overlapping segment; wherein the beneficial agents are loaded onto the prosthesis and the balloon to provide a controlled local areal density of beneficial agent across a length of the prosthesis when deployed. The method described in detail above is preferred for such loading step.

30           For purposes of explanation and illustration, and not limitation, an exemplary embodiment of the interventional device in accordance with the invention is shown schematically in Figure 2 and 3. In accordance with one aspect of the invention, as shown

schematically in Figure 2 and 3, the interventional device generally includes a prosthesis loaded with beneficial agent (preferably ABT-578, rapamycin, or rapamycin analogies, alone or in combination with an additional drug such as dexamethasone or estradiol) to provide a local delivery of a first beneficial agent across a treatment zone and a balloon with a second beneficial agent (preferably paclitaxel, taxanes, or other taxane derivatives, alone or in combination with an additional drug) delivered across a second overlapping treatment zone. Alternatively, the prosthesis could be loaded with beneficial agent (preferably paclitaxel, taxanes, or other taxane derivatives alone or in combination with an additional drug such as dexamethasone or estradiol) to provide a local delivery of a first beneficial agent across a treatment zone and a balloon with a second beneficial agent (preferably ABT-578, rapamycin, or rapamycin analogies, alone or in combination with an additional drug) delivered across a second overlapping treatment zone. Particularly, as embodied herein the prosthesis may be a stent, a graft or a stent-graft, as previously noted, for intravascular or coronary delivery and implantation. However, the prosthesis may be any type of implantable member capable of being loaded with beneficial agent. The balloon may be any type of catheter based expandable entity that can act to expand the prosthesis, the local tissue, or push the second beneficial agent against the lumen wall.

The present invention will be further understood by the examples set forth below, which are provided for purpose of illustration and not limitation.

The following examples demonstrate how various embodiments of the present invention may be practiced. By "simultaneous" it is meant that a coated prosthesis (e.g., stent) is mounted on a coated balloon and the stent and balloon are delivered to the desired location at the same time. By "independent", it is meant that the coated balloon is delivered either before or after the coated stent is delivered. By "combined", it is meant that beneficial agent(s) are delivered from both the balloon and the prosthesis to the vessel tissue."

## EXAMPLES

### Example 1. Loading of stents with beneficial agents or multiple beneficial agents

#### I. Coating the Stents with PC1036

Prior to any experimentation, coated stents are prepared. These are 3.0 mm X 15 mm 316L electropolished stainless steel stents. Each stent is spray coated using a filtered 20-mg/mL solution of phosphorylcholine polymer PC1036 (product of Biocompatibles Ltd., Farnham, Surrey, UK) in ethanol. The stents are initially air dried and then cured at 70°C for 16 hours. They are then sent for gamma irradiation at <25K Gy.

## II. Loading the Stents with Drugs of interest

In these experiments, beneficial agents are loaded onto stents and elution profiles examined. In general, the procedure is as follows. Multiple PC-coated stents are loaded with each of several drugs or combinations thereof from solution. The solutions of the drugs are usually in the range of 2 – 20 mg/mL of ABT-578 and 10.0 mg/mL dexamethasone in 100% ethanol, with ~ 10% PC1036 added to the solution to enhance film formation.

The stents are weighed before loading with the drug solution. To load approximately 10 µg/mL of each drug, a solution with equal amounts of ABT-578 and dexamethasone is sprayed onto the stent in a controlled fashion. The stent is allowed to dry before the stents are re-weighed to determine total drug load. The loaded, dry stents are stored in a refrigerator and are protected from light.

## III. Extracting Drugs from the Stents

For each drug, 3 stents are used to evaluate the total amount of drug loaded by the above procedure. The stents are immersed in 6 mL of 50% ethanol, 50% water solution and sonicated for 20 minutes. The concentration of the drug in the extraction solution is analyzed by HPLC.

## 25 Example 2. Loading of balloons with beneficial agents or multiple beneficial agents

### I. Preparing the balloon for drug loading

Multiple balloons (Jomed 15mm X 3.0 mm) are rolled to minimize the final catheter crossing profile. If needed the balloons were washed in ethanol.

### II. Loading the balloon with Drugs of interest

In these experiments, beneficial agents are loaded onto balloons. In general, the procedure is as follows. Multiple balloons (Jomed 15mm X 3.0 mm) are loaded with paclitaxel from a solution. The solutions of paclitaxel are usually in the range of 2 – 20 mg/mL of paclitaxel in 100% ethanol.

5 The balloons are weighed before loading with the drug solution. To load approximately 200 to 600 ug of paclitaxel, the balloons are dipped into a solution of paclitaxel. The balloon is removed in a controlled fashion to control drying. The stent is allowed to dry before the balloons are re-weighed to determine total drug load. The loaded, dry balloons are stored at room temperature and are protected from light.

10

### III. Extracting Drugs from the Balloon

For each drug, 3 balloons are used to evaluate the total amount of drug loaded by the above procedure. The balloons are expanded and immersed in 6 mL of 50% ethanol, 50% water solution and sonicated for 20 minutes. The concentration of the drug in the extraction solution is analyzed by HPLC.

15

#### Example 3. Crimping of beneficial agent-coated stents onto beneficial agent-coated balloons.

Multiple stents loaded with ABT-578 and top coated with PC1036 are placed over the end of catheter balloons which have been coated with paclitaxel. The stent is centered over the radiopaque markers of the balloon and crimped onto the balloon using a Machine Solutions drug eluting stent crimper. The stent-balloon final product is then leak-tested and visually inspected to ensure the quality of the final product. The catheter assembly is then packaged in Tyvek pouches, labeled, and ETO sterilized.

20

#### 25 Example 4. Simultaneous combined delivery of a first beneficial agent on prosthesis and a second beneficial agent on Balloon

This example describes delivery of a stent containing at least one beneficial agent using a balloon coated with a second beneficial agent(s). In this example, a prosthesis will be coated with at least one beneficial agent and will be mounted on an angioplasty balloon which has been coated with a second beneficial agent(s). This complete system will be inserted into the body via a peripheral vessel, and advanced to the lesion targeted for treatment. After location at the lesion site, the angioplasty balloon containing the second beneficial agent(s) will be

30

expanded, simultaneously delivering said beneficial agent(s) as well as deploying the prosthesis containing the first beneficial agent(s). The simultaneous delivery will use a technique often described as direct stenting, in which no pre-dilatation of the vessel at the site of the lesion is involved and the delivery of each beneficial agent begins during the same time period. Alternatively, the simultaneous delivery can be completed after pre-dilatation with an uncoated balloon or with a coated balloon. When deployment of the prosthesis is complete, the balloon will be deflated and removed from the body, leaving the prosthetic device in place to continue delivering the first beneficial agent(s) over time. Beneficial agents on the prosthesis or the balloon can be the same or different.

10 Example 5. Independent combined delivery of first beneficial agent(s) on prosthesis and second beneficial agent(s) on Balloon

A balloon coated with one or more beneficial agents, but containing no prosthesis, will be inserted into the body, and advanced to the lesion site where it will be dilated to expand the vessel. This technique is commonly described as pre-dilatation. Delivery of a second beneficial agent(s) to the lesion site will proceed upon expansion of this balloon. The balloon will then be deflated and removed from the body. At that time, a second intervention, in which a second balloon without a beneficial agent, containing a prosthesis coated with one or more beneficial agents, will be introduced via the peripheral vessel. Upon expansion of the second balloon at the pre-dilated lesion site, the prosthesis will be expanded and will begin to deliver one or more beneficial agents to the lesion. The second balloon will then be removed from the body.

25 Example 6. Independent combined delivery of first beneficial agent(s) on prosthesis with a post-expansion delivery of a second beneficial agent(s) from a balloon.

This procedure involves the delivery of a prosthesis containing a first beneficial agent(s), using a balloon that has no beneficial agent. In this case, the balloon catheter, containing a drug-loaded prosthesis, is advanced to the lesion site, and expanded to deliver the device and initiate the delivery of the beneficial agent(s). The balloon is then deflated and removed from the body. At this time, a second balloon, coated with a second beneficial agent(s), is inserted into the peripheral vessel and advanced to the lesion site. A second balloon expansion is then conducted to further expand the previously placed stent or to deliver a second beneficial

agent or agents to the site of the lesion. Beneficial agents on the prosthesis or the balloon can be the same or different.

Example 7. Delivery of a second beneficial agent on balloon to treat in-stent restenosis.

5 This intervention involves the dilation of a vessel with a balloon that is coated with a second beneficial agent(s) at a restenosed lesion site where a stent or stents have been previously placed. In this way, restenosis of a vessel in which an intervention has previously failed can be adequately treated without placement of an additional prosthesis or prosthesis at the same site.

10

As will be recognized by those of ordinary skill, the examples can be adapted to address situations for which it is desired to deliver multiple stents, e.g., "kissing" stents or overlapping stents.

What is claimed is:

1. A system for delivering a beneficial agent, comprising:

- a) a balloon having an outer surface that is at least partially coated with a therapeutically effective amount of a first beneficial agent; and
- b) a prosthesis that can be delivered or implanted having a surface that is at least partially coated with a therapeutically effective amount of a second beneficial agent

wherein the system is useful for the treatment and prevention of vascular diseases.

2. A system according to claim 1, wherein the balloon is an angioplasty balloon.

3. A system according to claim 1, wherein the prosthesis is a stent.

4. A system according to claim 3, wherein said prosthesis is crimped onto said balloon.

5. A system according to claim 1, wherein said prosthesis is at least partially retained on said balloon by said coating on said balloon.

6. A system according to claim 3, wherein the stent is a self-expanding stent.

7. A system according to claim 1, wherein the coating on the balloon further comprises a carrier for said first beneficial agent.

8. A system according to claim 6, wherein the carrier is selected from the group consisting of complex sugars (mannitol) starches (cellulose), collagens, and polymeric materials.

9. A system according to claim 1, wherein the coating on the prosthesis further comprises a carrier for said second beneficial agent.



10. A system according to claim 9, wherein said carrier for said second beneficial agent is selected from a group consisting of phosphorylcholine, polycaprolactone, poly-D,L-lactic acid, poly-L-lactic acid, poly(lactide-co-glycolide), poly(hydroxybutyrate), poly(hydroxybutyrate-co-valerate), polydioxanone, polyorthoester, polyanhydride, poly(glycolic acid), poly(glycolic acid-co-trimethylene carbonate), polyphosphoester, polyphosphoester urethane, poly(amino acids), cyanoacrylates, poly(trimethylene carbonate), poly(iminocarbonate), polyalkylene oxalates, polyphosphazenes, polyiminocarbonates, and aliphatic polycarbonates, fibrin, fibrinogen, cellulose, starch, collagen, Parylene®, Parylast®, polyurethane, polycarbonate urethanes, polyethylene, polyethylene terephthalate, ethylene vinyl acetate, ethylene vinyl alcohol, silicone polysiloxanes, substituted polysiloxanes, polyethylene oxide, polybutylene terephthalate-co-PEG, PCL-co-PEG, PLA-co-PEG, polyacrylates, polyvinyl pyrrolidone, polyacrylamide, thermoplastic elastomers, polyolefin elastomers, EPDM rubbers, polyamide elastomers, biostable plastic, acrylic polymers, nylon, polyesters, epoxies and derivatives or combinations thereof.

11. A system according to claim 1, further comprising a balloon which is substantially free of a beneficial agent.

12. A system according to claim 1, wherein the first beneficial agent is the same as the second beneficial agent.

13. A system according to claim 1, wherein a surface of said prosthesis is loaded with therapeutically effective amounts of more than one beneficial agent.

14. A system according to claim 1, wherein the first beneficial agent and the second beneficial agent are individually selected from the group consisting of antithrombotics, anticoagulants, antiplatelet agents, anti-lipid agents, thrombolytics, antiproliferatives, anti-inflammatories, agents that inhibit hyperplasia, smooth muscle cell inhibitors, antibiotics, growth factor inhibitors, cell adhesion inhibitors, cell adhesion promoters, antimetotics, antifibrins, antioxidants, antineoplastics, agents that promote endothelial cell recovery, antiallergic substances, viral vectors, nucleic acids, monoclonal antibodies, antisense compounds,

oligonucleotides, cell permeation enhancers, radiopaque agent markers, HMG CoA reductase inhibitors, pro-drugs and combinations thereof. .

15. A system according to claim 9, wherein said HMG CoA reductase inhibitor is selected from the group consisting of atorvastatin, simvastatin, pravastatin, lovastatin, cerivastatin, fluvastatin.

16. The system according to claim 1, wherein the first and second beneficial agents are individually selected from the group of indomethacin, phenyl salicylate, vinblastine, ABT-627 (atrasentan), ABT-578, testosterone, progesterone, paclitaxel, taxanes, cyclosporin A, vincristine, carvedilol, vandesine, dipyridamole, methotrexate, folic acid, thrombospondin mimetics, estradiol, dexamethasone, metrizamide, iopamidol, iohexol, iopromide, iobitridol, iomeprol, iopentol, ioversol, ioxilan, iodixanol, iotrolan, rapamycin, rapamycin derivatives, pimecrolimus, everolimus, fenofibrate, carvedilol, taxoteres, tacrolimus, peroxisomal proliferator activated receptor  $\gamma$  (PPAR- $\gamma$ ) agonists, paricalcitol, butylated hydroxytoluene, butylated hydroxyanisole, vitamin E, danazol, probucol, tocopherols, tocotrienols and pro-drugs, analogs, derivatives, or combinations thereof.

17. The system according to claim 16, wherein the PPAR- $\gamma$  agonist is a thiazolidinedione.

18. The system according to claim 1, wherein the beneficial agent is a nucleic acid that encodes a pharmaceutically useful peptide or an anti-sense oligonucleotide used to control a gene of interest in a cell of the patient.

19. A system according to claim 1, further comprising additional prostheses.

20. A system according to claim 1, wherein the coating on the balloon is discontinuous.

21. A system according claim 1, wherein the coating on the balloon forms a pattern.

22. A system according to claim 4, wherein the length of said coating on the balloon extends past the length of said prosthesis crimped on said balloon.

23. A system according to claim 6, wherein said coated balloon is delivered after said stent is implanted to accomplish final sizing of said stent.
24. A system according to claim 1, wherein said first beneficial agent is transferred from said coating on said balloon into said coating on said prosthesis.
25. A system according to claim 1, wherein said coating on said prosthesis comprises a barrier to transfer of said first beneficial agent from said coating on said balloon into said coating on said prosthesis or of said second beneficial agent from said coating on said prosthesis into said coating on said balloon.
26. A system according to claim 25, wherein said barrier is polymeric.
27. The system according to claim 26, wherein the polymeric component is selected from a group consisting of phosphorylcholine, polycaprolactone, poly-D,L-lactic acid, poly-L-lactic acid, poly(lactide-co-glycolide), poly(hydroxybutyrate), poly(hydroxybutyrate-co-valerate), polydioxanone, polyorthoester, polyanhydride, poly(glycolic acid), poly(glycolic acid-co-trimethylene carbonate), polyphosphoester, polyphosphoester urethane, poly(amino acids), cyanoacrylates, poly(trimethylene carbonate), poly(iminocarbonate), polyalkylene oxalates, polyphosphazenes, polyiminocarbonates, and aliphatic polycarbonates, fibrin, fibrinogen, cellulose, starch, collagen, Parylene®, Parylast®, polyurethane, polycarbonate urethanes, polyethylene, polyethylene terephthalate, ethylene vinyl acetate, ethylene vinyl alcohol, silicone polysiloxanes, substituted polysiloxanes, polyethylene oxide, polybutylene terephthalate-co-PEG, PCL-co-PEG, PLA-co-PEG, polyacrylates, polyvinyl pyrrolidone, polyacrylamide, thermoplastic elastomers, polyolefin elastomers, EPDM rubbers, polyamide elastomers, biostable plastic, acrylic polymers, nylon, polyesters, epoxies and derivatives or combinations thereof.
28. A method of treating and preventing a vascular disease using the system of claim 1.

29. A system according to claim 24, wherein said first beneficial agent is delivered from said coating on said prosthesis into a target site.
30. A system according to claim 1, wherein said coating on said balloon contains multiple beneficial agents.
31. A system according to claim 1, wherein said coating on said prosthesis contains multiple beneficial agents.
32. A method of treating and preventing a vascular disease, comprising the steps of:
- a) delivering a balloon having an outer surface that is at least partially coated with a therapeutically effective amount of a first beneficial agent; and
  - b) delivering a prosthesis having a surface that is at least partially coated with therapeutically effective amount of a second beneficial agent.
33. A method according to claim 40, wherein first beneficial agent is not the same as the second beneficial agent.
34. A method according to claim 40, wherein step a and step b are performed simultaneously.
35. A method according to claim 42, wherein said balloon is adhered to said prosthesis by said coating on said balloon.
36. A method according to claim 40, wherein step a and step b are performed in sequence.
37. A method according to claim 40, wherein step a is performed before step b and said balloon is delivered during angioplasty.
38. A method according to claim 40, further comprising the step of using an uncoated balloon.

39. A method according to claim 40, wherein step b is performed prior to step a.
40. A method according to claim 47, wherein said prosthesis is a self-expanding stent.
41. A method according to claim 48, wherein said coated balloon is used for final sizing of said coated stent.
42. A system according to claim 24, wherein said first beneficial agent is delivered from said coating on said prosthesis into a target site.
43. A method of providing a device for treatment and prevention of vascular disease, comprising the steps of:
- a) providing a beneficial agent; and
  - b) coating said beneficial agent onto said balloon.
44. A method according to claim 60, wherein said coating step is accomplished by dipping, spraying, layering, painting or jetting.
45. A method according to claim 60, wherein said beneficial agent is coated from a solution.
46. A method according to claim 62, wherein said solution comprises at least one solvent.
47. A method according to claim 63, wherein said at least one solvent is selected from the group consisting of water, alcohols, dichloromethane, dimethylsulfoxide, ethanol, isopropyl alcohol, isobutyl alcohol, tetrahydrofuran, alkanes, dimethylformamide and mixtures thereof.
48. A method according to claim 60, further comprising the step of providing a prosthesis for use in association with said coated balloon.

49. A method according to claim 60, further comprising the step of enhancing retention of said prosthesis by mounting said prosthesis on said coated balloon prior to complete drying or curing of said coating on said balloon.

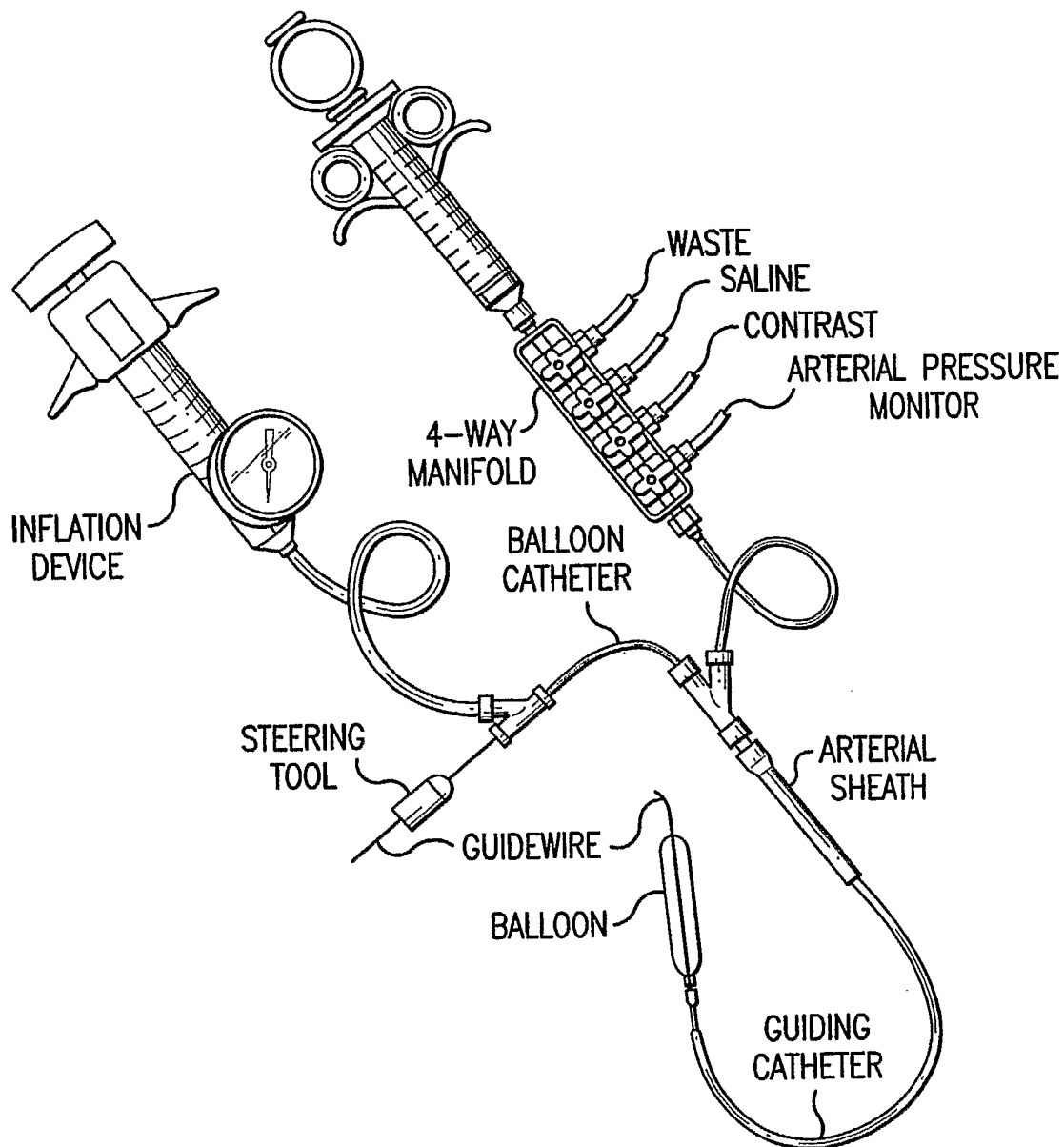

FIG. 1

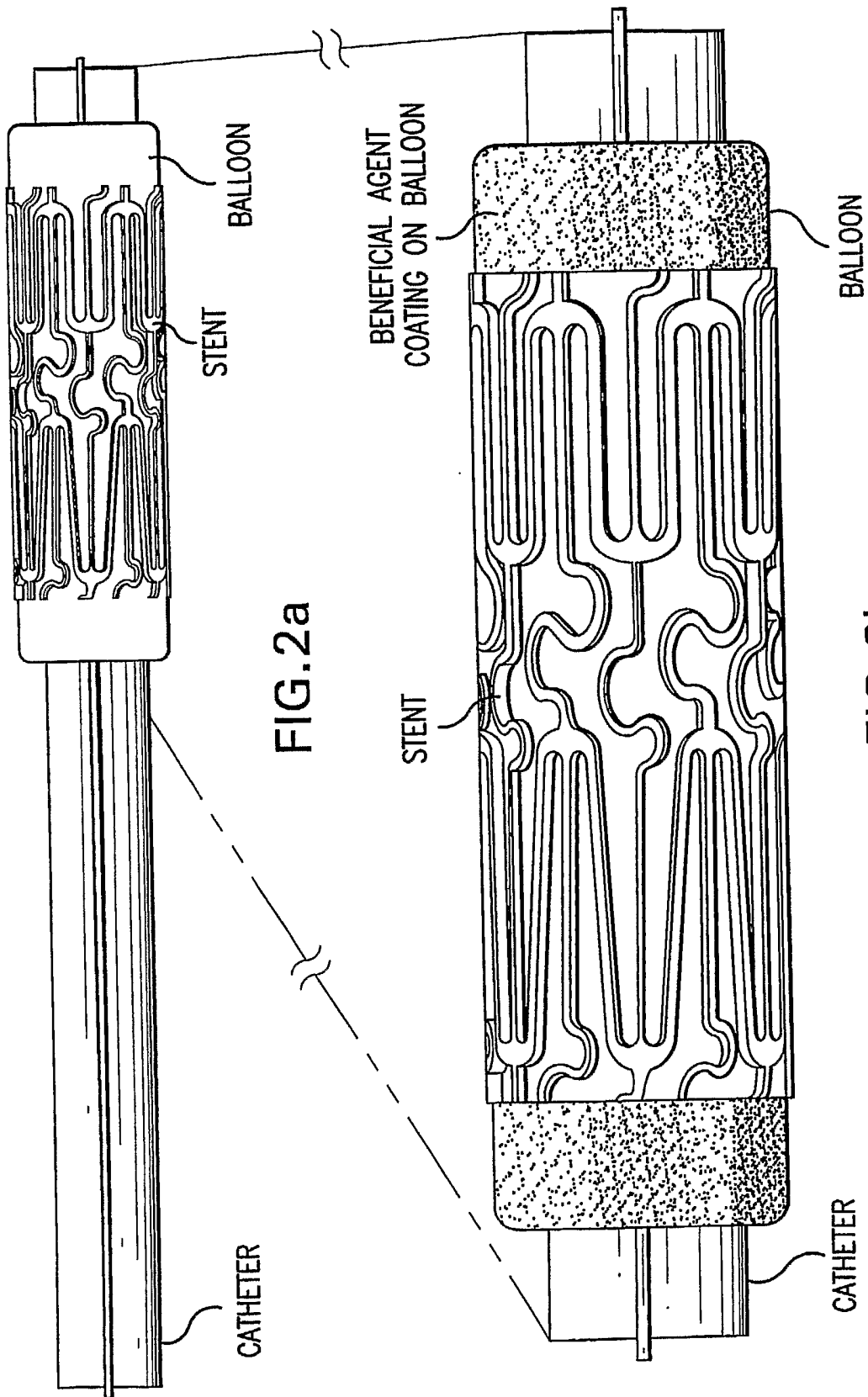

FIG. 2a

FIG. 2b



3/6

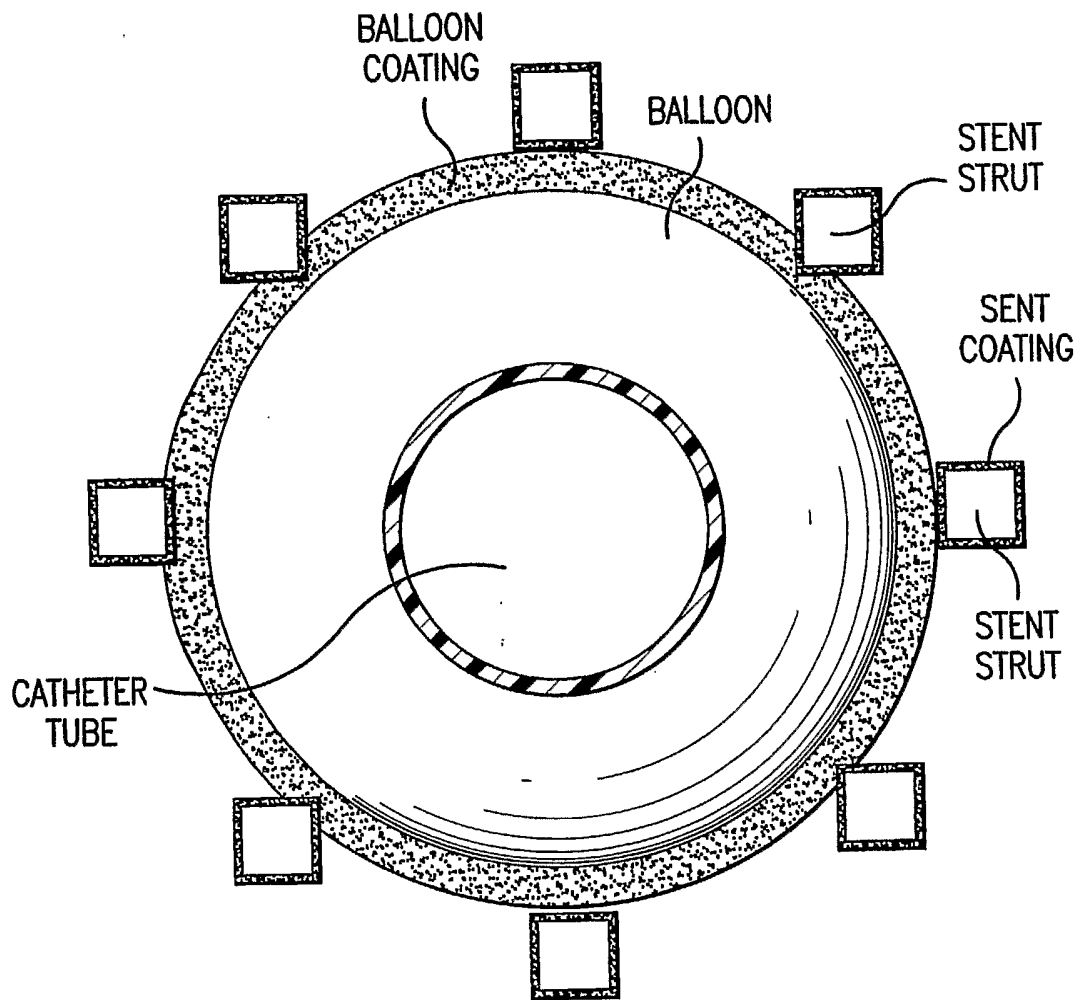

FIG.3

FIG. 4a

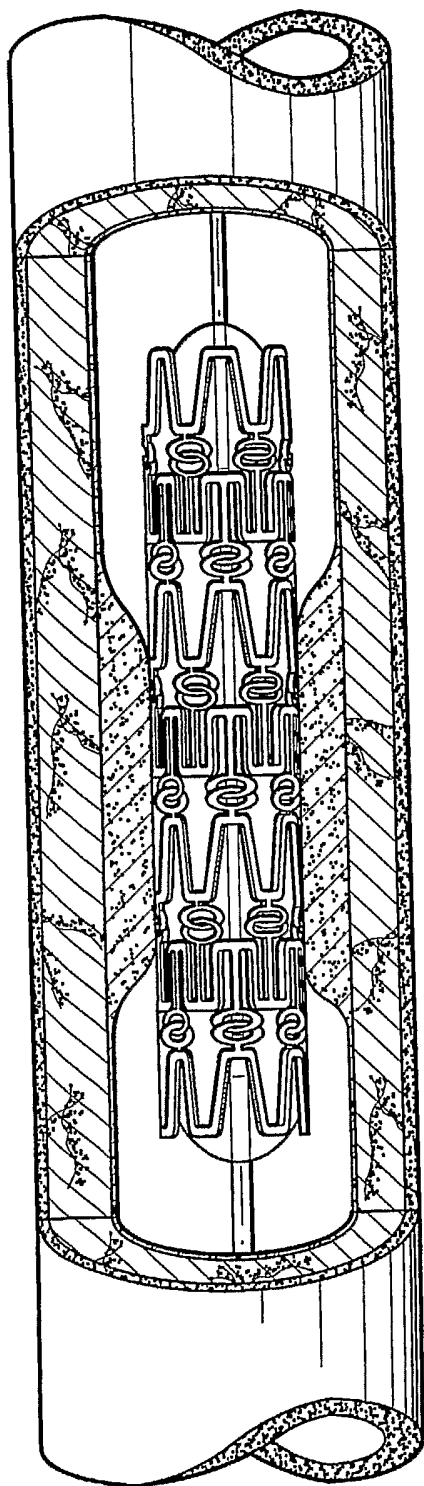
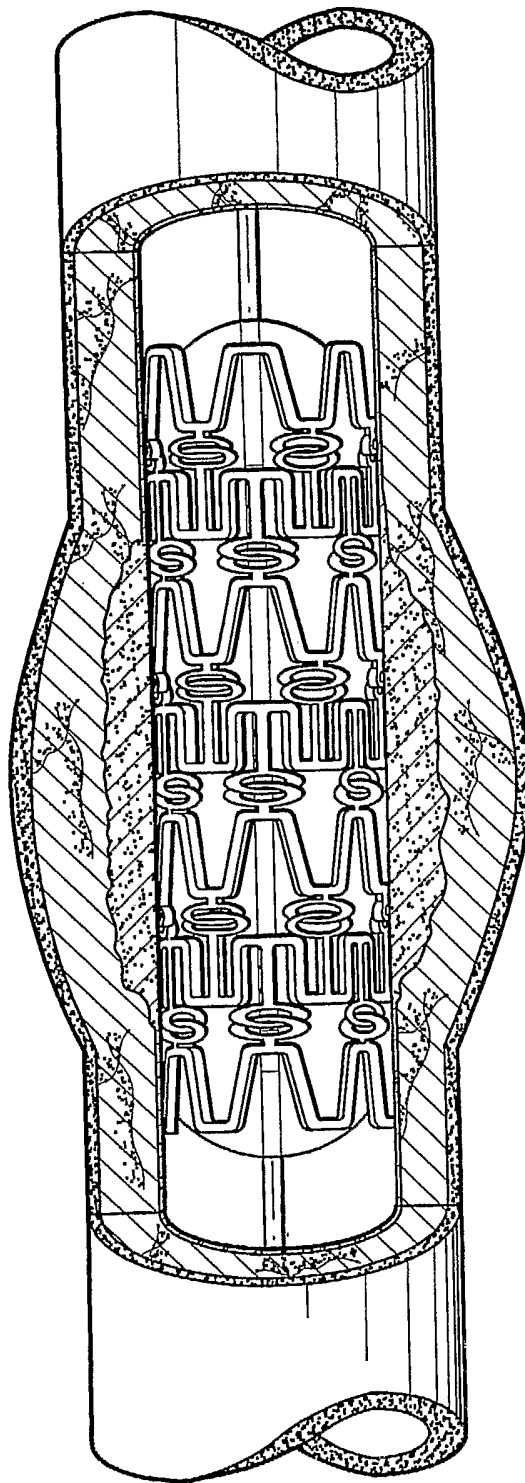

FIG. 4b



5/6

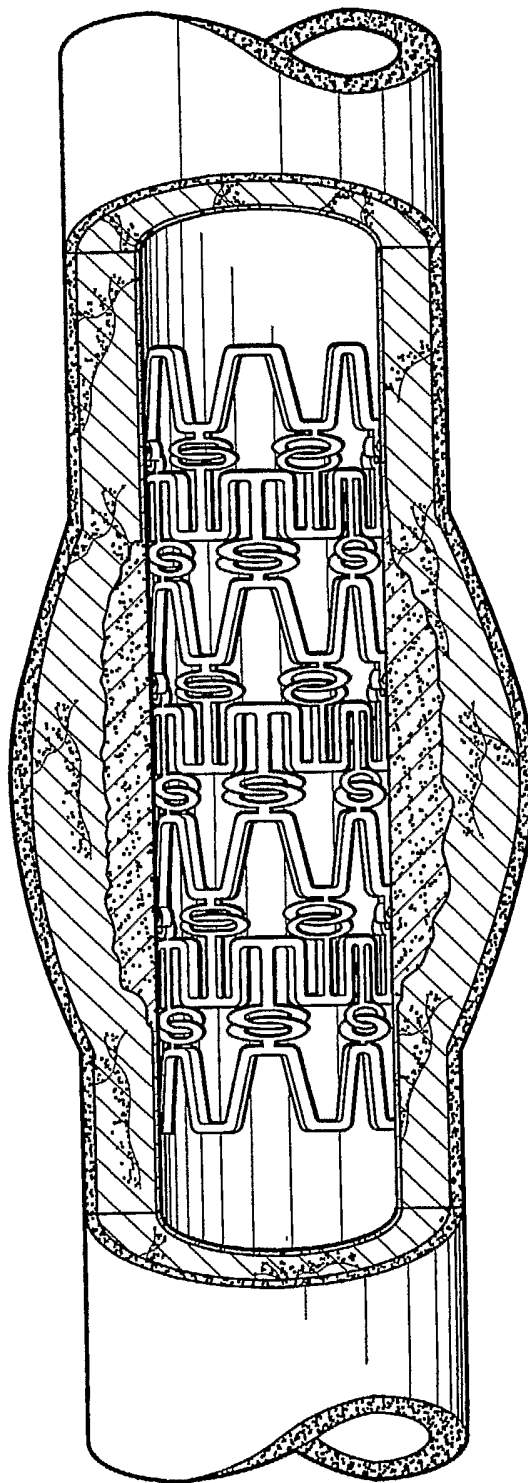

FIG.4c

6/6

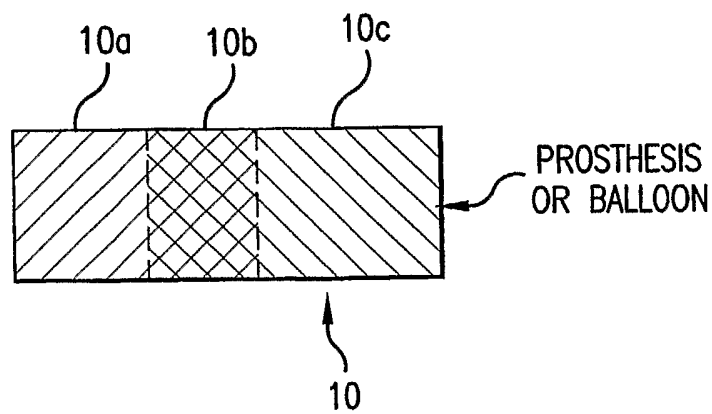

FIG.5a

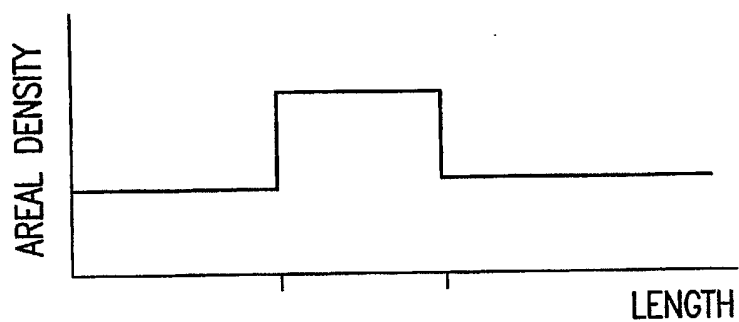

FIG.5b

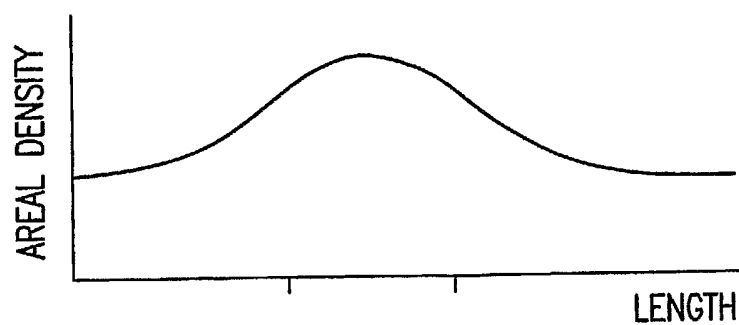

FIG.5c

# INTERNATIONAL SEARCH REPORT

International Application No  
PCT/US2005/009310

**A. CLASSIFICATION OF SUBJECT MATTER**  
 IPC 7 A61M25/10 A61F2/06 A61L27/28 A61L31/08

According to International Patent Classification (IPC) or to both national classification and IPC

**B. FIELDS SEARCHED**  
 Minimum documentation searched (classification system followed by classification symbols)  
 IPC 7 A61M A61L A61F

Documentation searched other than minimum documentation to the extent that such documents are included in the fields searched

Electronic data base consulted during the international search (name of data base and, where practical, search terms used)  
 EPO-Internal, WPI Data, PAJ, CHEM ABS Data, MEDLINE, EMBASE, BIOSIS

**C. DOCUMENTS CONSIDERED TO BE RELEVANT**

Category °	Citation of document, with indication, where appropriate, of the relevant passages	Relevant to claim No.
X	US 5 591 227 A (DINH ET AL) 7 January 1997 (1997-01-07) cited in the application abstract column 2, line 35 - column 3, line 46 column 10, line 61 - column 11, line 62 claims 1-11	1-31, 40-50, 60-66
X	EP 0 623 354 A (MEDTRONIC, INC) 9 November 1994 (1994-11-09) abstract page 2, line 1 - line 2 page 2, line 42 - page 3, line 22 examples 3-5,7 claims 1-19	1-31, 40-50, 60-66

Further documents are listed in the continuation of box C.       Patent family members are listed in annex.

° Special categories of cited documents :

<p>"A" document defining the general state of the art which is not considered to be of particular relevance</p> <p>"E" earlier document but published on or after the international filing date</p> <p>"L" document which may throw doubts on priority claim(s) or which is cited to establish the publication date of another citation or other special reason (as specified)</p> <p>"O" document referring to an oral disclosure, use, exhibition or other means</p> <p>"P" document published prior to the international filing date but later than the priority date claimed</p>	<p>"T" later document published after the international filing date or priority date and not in conflict with the application but cited to understand the principle or theory underlying the invention</p> <p>"X" document of particular relevance; the claimed invention cannot be considered novel or cannot be considered to involve an inventive step when the document is taken alone</p> <p>"Y" document of particular relevance; the claimed invention cannot be considered to involve an inventive step when the document is combined with one or more other such documents, such combination being obvious to a person skilled in the art.</p> <p>"&amp;" document member of the same patent family</p>
--	--

Date of the actual completion of the international search  <b>12 July 2005</b>	Date of mailing of the international search report  <b>25/07/2005</b>
--	---

Name and mailing address of the ISA European Patent Office, P.B. 5818 Patentlaan 2 NL - 2280 HV Rijswijk Tel. (+31-70) 340-2040, Tx. 31 651 epo nl, Fax: (+31-70) 340-3016	Authorized officer   <b>Taylor, G.M.</b>
--	---

## INTERNATIONAL SEARCH REPORT

 International Application No  
 PCT/US2005/009310

## C.(Continuation) DOCUMENTS CONSIDERED TO BE RELEVANT

Category °	Citation of document, with indication, where appropriate, of the relevant passages	Relevant to claim No.
A	US 6 033 434 A (BORGHI ET AL) 7 March 2000 (2000-03-07) cited in the application abstract figures 1-8 column 4, line 3 - line 28 column 10, line 45 - line 48 claims 1-39 -----	1-31, 40-50, 60-66
A	US 5 755 771 A (PENN ET AL) 26 May 1998 (1998-05-26) cited in the application abstract figures 1-6 column 4, line 61 - line 67 column 5, line 1 - line 24 claims 1-46 -----	1-31, 40-50, 60-66
A	US 5 591 195 A (TAHERI ET AL) 7 January 1997 (1997-01-07) abstract figures 1-8 column 2, line 21 - line 48 column 7, line 6 - line 51 column 14, line 6 - line 39 claims 1-14 -----	1-31, 40-50, 60-66
A	US 4 733 665 A (PALMAZ ET AL) 29 March 1988 (1988-03-29) cited in the application abstract figures 1-4 column 3, line 18 - column 5, line 13 claims 1-28 -----	1-31, 40-50, 60-66

# INTERNATIONAL SEARCH REPORT

Information on patent family members

International Application No  
PCT/US2005/009310

Patent document cited in search report	Publication date	Patent family member(s)	Publication date
US 5591227	A	07-01-1997	US 559352 A 04-02-1997
			US 5957971 A 28-09-1999
			DE 69527900 D1 02-10-2002
			DE 69527900 T2 27-03-2003
			EP 0701802 A1 20-03-1996
			JP 8089585 A 09-04-1996
			US 5697967 A 16-12-1997
			US 6080190 A 27-06-2000
			US 5571166 A 05-11-1996
			US 5591224 A 07-01-1997
			US 5510077 A 23-04-1996
			US 5554182 A 10-09-1996
			US 5800507 A 01-09-1998
			US 5628785 A 13-05-1997
			US 5849034 A 15-12-1998
			DE 69326631 D1 11-11-1999
			DE 69326631 T2 08-06-2000
			EP 0566245 A1 20-10-1993
			JP 6007455 A 18-01-1994
			EP 0623354
DE 9422438 U1 25-04-2002			
DE 69431457 D1 07-11-2002			
DE 69431457 T2 26-06-2003			
EP 1181943 A1 27-02-2002			
EP 0623354 A1 09-11-1994			
JP 8033718 A 06-02-1996			
US 2002138048 A1 26-09-2002			
US 5837008 A 17-11-1998			
US 5679400 A 21-10-1997			
US 5624411 A 29-04-1997			
US 5776184 A 07-07-1998			
US 5824048 A 20-10-1998			
US 6033434	A	07-03-2000	IT B0950292 A1 09-12-1996
			IT B0960201 A1 15-10-1997
			IT B0960202 A1 15-10-1997
			AU 5776696 A 09-01-1997
			BR 9608708 A 07-12-1999
			DE 69630379 D1 20-11-2003
			DE 69630379 T2 06-05-2004
			EP 0830109 A1 25-03-1998
			JP 11513903 T 30-11-1999
			AU 5675196 A 09-01-1997
			BR 9608928 A 14-12-1999
			CA 2223479 A1 27-12-1996
			CA 2223502 A1 27-12-1996
			DE 69630030 D1 23-10-2003
			DE 69630030 T2 09-06-2004
			EP 0830108 A1 25-03-1998
			WO 9641591 A1 27-12-1996
			WO 9641592 A1 27-12-1996
			JP 11507567 T 06-07-1999
			US 6113628 A 05-09-2000
US 5755771	A	26-05-1998	CA 2134997 A1 04-05-1996
			AT 166783 T 15-06-1998
			AT 231366 T 15-02-2003

## INTERNATIONAL SEARCH REPORT

Information on patent family members

International Application No

PCT/US2005/009310

Patent document cited in search report	Publication date	Patent family member(s)	Publication date			
US 5755771	A	AU 3678599	A 28-10-1999			
		AU 3739795	A 31-05-1996			
		WO 9614028	A1 17-05-1996			
		CZ 9701329	A3 17-12-1997			
		DE 69502817	D1 09-07-1998			
		DE 69502817	T2 25-02-1999			
		DE 69529480	D1 27-02-2003			
		DE 69529480	T2 27-11-2003			
		DK 751752	T3 22-03-1999			
		EP 0751752	A1 08-01-1997			
		EP 0847734	A2 17-06-1998			
		ES 2119487	T3 01-10-1998			
		GR 3027774	T3 30-11-1998			
		HK 1009322	A1 28-05-1999			
		JP 10508234	T 18-08-1998			
		RU 2180198	C2 10-03-2002			
		US 6099560	A 08-08-2000			
		US 5906640	A 25-05-1999			
		US 5591195	A	07-01-1997	AU 724820	B2 28-09-2000
					AU 7479496	A 22-05-1997
CA 2235675	A1 09-05-1997					
EP 0862481	A1 09-09-1998					
JP 2001502926	T 06-03-2001					
US 2002077634	A1 20-06-2002					
WO 9716219	A1 09-05-1997					
US 6287315	B1 11-09-2001					
US 6334869	B1 01-01-2002					
US 5713917	A 03-02-1998					
US 2004236403	A1 25-11-2004					
US 2002065545	A1 30-05-2002					
US 4733665	A	29-03-1988	AT 60500	T 15-02-1991		
			AU 591942	B2 21-12-1989		
			AU 6488286	A 14-05-1987		
			BR 8605658	A 15-12-1987		
			CA 1281504	C 19-03-1991		
			CA 1281505	C 19-03-1991		
			CA 1338303	B 07-05-1996		
			DE 3677321	D1 07-03-1991		
			DE 221570	T1 17-12-1987		
			EP 0221570	A2 13-05-1987		
			ES 2020502	T5 16-03-2001		
			GR 3001410	T3 25-09-1992		
			GR 3035143	T3 30-04-2001		
			JP 2731642	B2 25-03-1998		
			JP 4357949	A 10-12-1992		
			JP 1719657	C 14-12-1992		
			JP 4006377	B 05-02-1992		
			JP 62231657	A 12-10-1987		
			JP 2999731	B2 17-01-2000		
			JP 9276302	A 28-10-1997		
US 5102417	A 07-04-1992					
US 4776337	A 11-10-1988					
US 4739762	A 26-04-1988					
ZA 8608414	A 30-09-1987					