

[54] **FOLDING SCREEN FOR LIGHT PERMEABLE SKYLIGHTS AND THE LIKE**

[76] Inventor: **Charles R. Gates**, 15070 Hill Drive, Novelty, Ohio 44072

[22] Filed: **Mar. 5, 1975**

[21] Appl. No.: **555,365**

**Related U.S. Application Data**

[63] Continuation-in-part of Ser. No. 462,172, April 18, 1974, which is a continuation of Ser. No. 242,649, April 10, 1972.

[52] **U.S. Cl.**..... **160/183; 160/206**

[51] **Int. Cl.<sup>2</sup>**..... **E05D 15/26**

[58] **Field of Search** ..... 160/133, 174, 183, 188, 160/193, 199, 206, 229, 235; 49/371

[56] **References Cited**

**UNITED STATES PATENTS**

2,505,155	4/1950	Smith.....	49/371
2,561,206	7/1951	Kasper.....	160/229
2,839,135	6/1958	Anderson.....	160/133
3,219,101	11/1965	Prehn.....	160/193
3,265,117	8/1966	Lorentzen.....	160/174
3,333,621	8/1967	Elder.....	160/206
3,348,516	10/1967	Caillet.....	160/188

*Primary Examiner*—Kenneth Downey  
*Attorney, Agent, or Firm*—Alfred D. Lobo

[57] **ABSTRACT**

A folding screen formed by a plurality of successively hinged, rigid, radiation-controlling panels supported for horizontal, planar movement in a pair of parallel, overhead tracks and operated by a flexible drive member extending along the track and connected to the lead panel. Since each panel is supported in the tracks only at its ends, each panel must possess sufficient rigidity to permit hinged, side-by-side coaction of interconnected panels from a stacked, generally vertical relationship to a generally horizontal, planar relationship. To enable the screen to be collapsed from an extended planar position without jamming, alternate hinges are vertically upwardly displaced. In a particular embodiment the hinges are provided with rollers at the ends thereof. Rollers for the lower and upper hinges travel in lower and upper levels, respectively, of each overhead track.

A particularly useful elongated panel for a radiation screen under a light-permeable building component comprises an arcuate extrudate bounded at the sides by relatively thick discontinuous ribs, each of sufficient thickness to have an axial bore adapted to journal a rod for hingedly connecting adjacent panels for horizontal, side-by-side coaction from a collapsed, distensible stack of plural panels into an extended, collapsible radiation screen, and vice versa.

**4 Claims, 10 Drawing Figures**

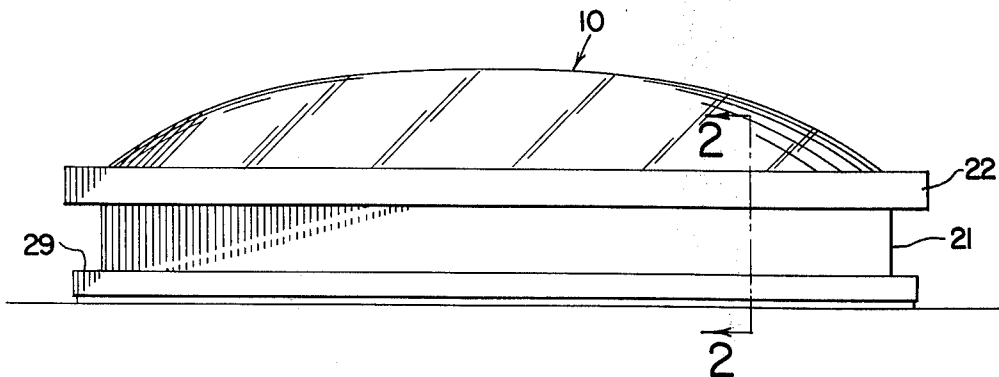

FIG. 1

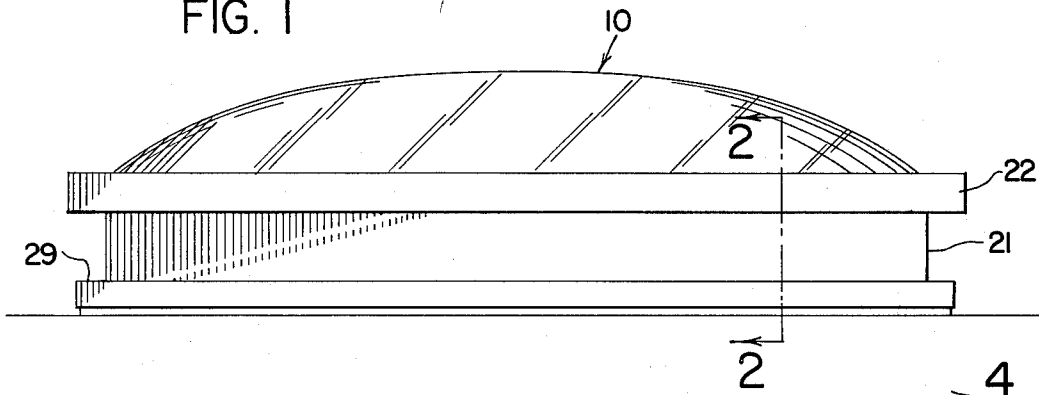

FIG. 2

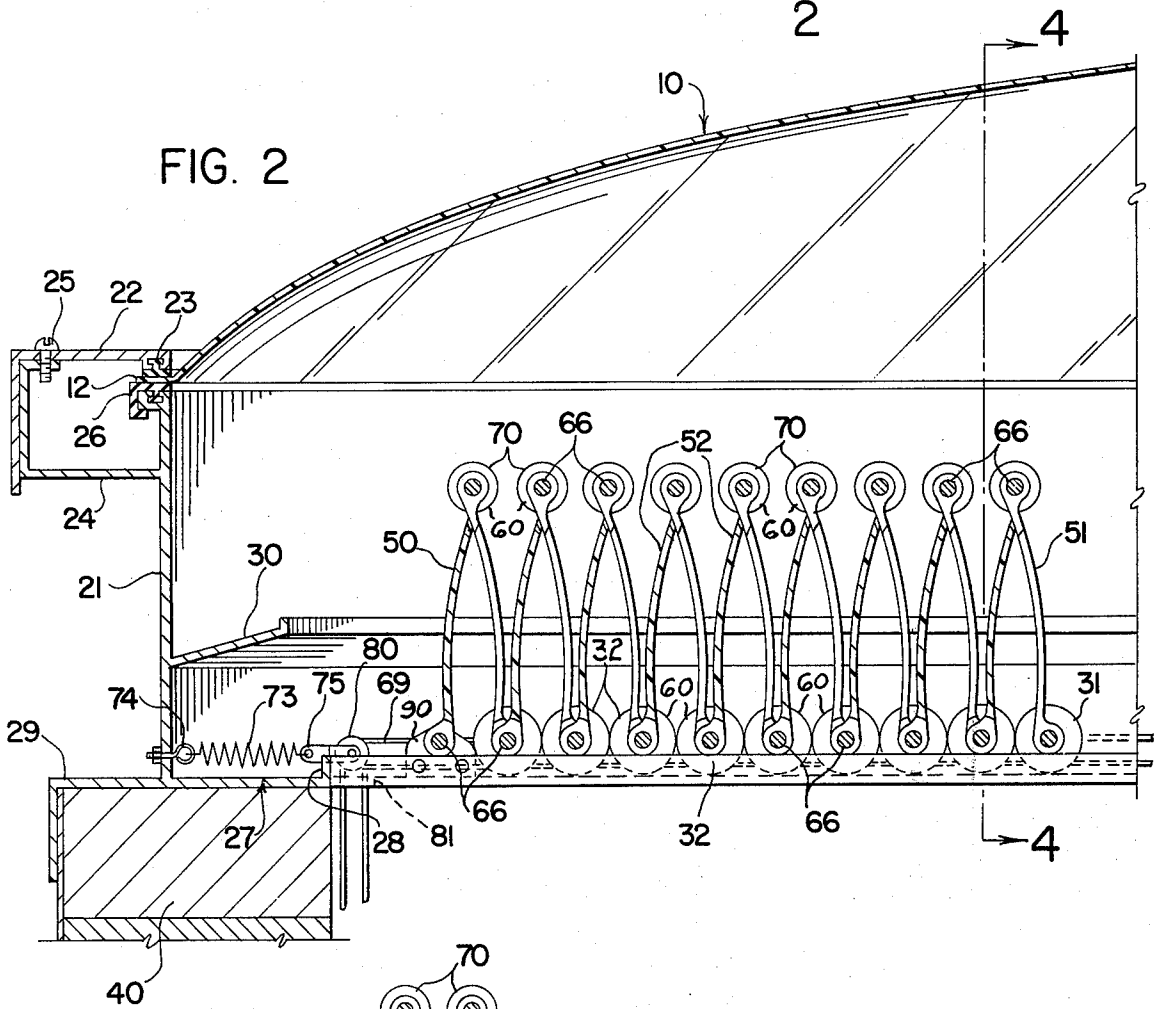

FIG. 3

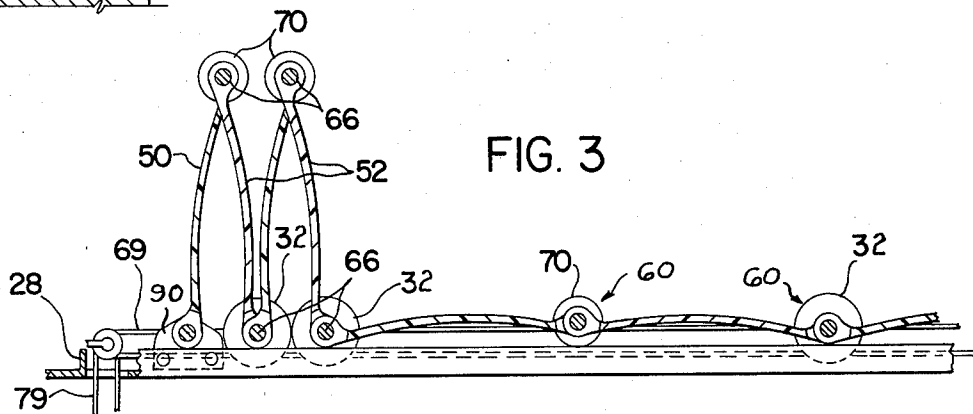

FIG. 4

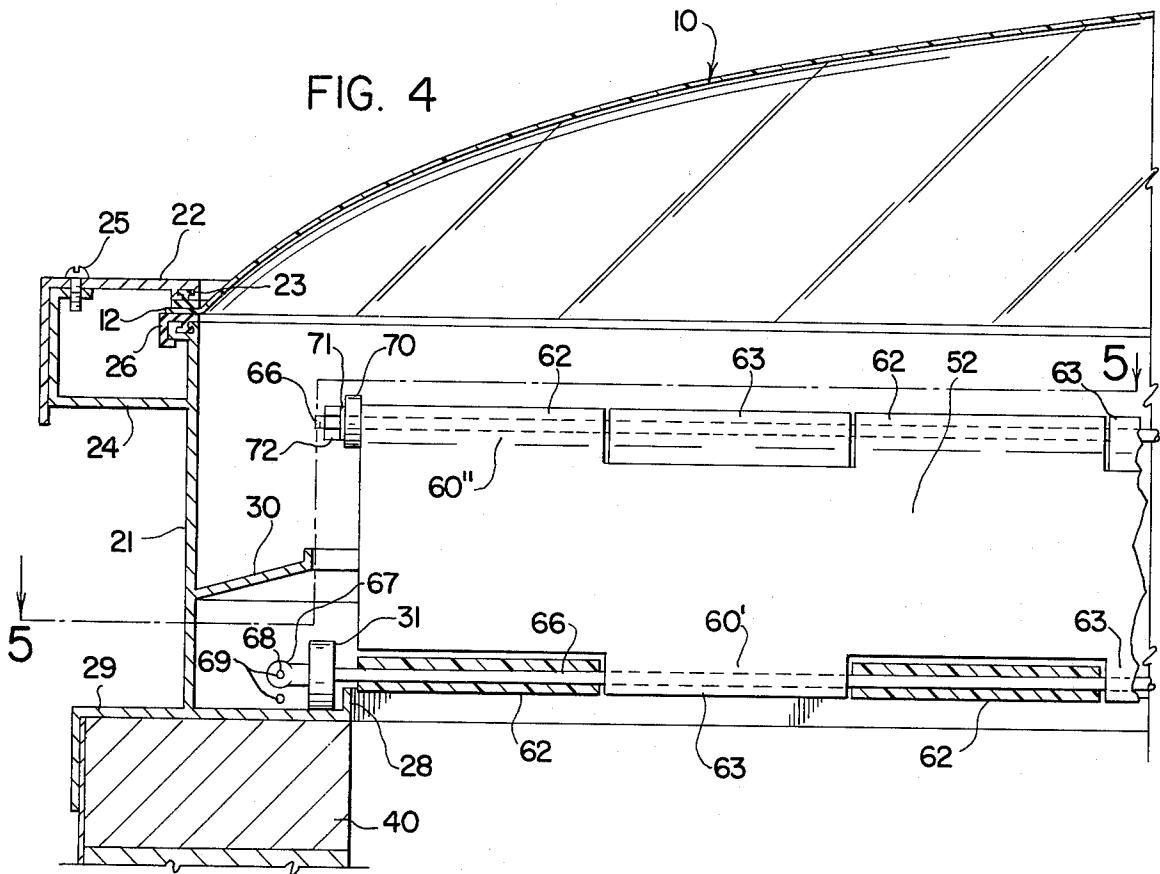
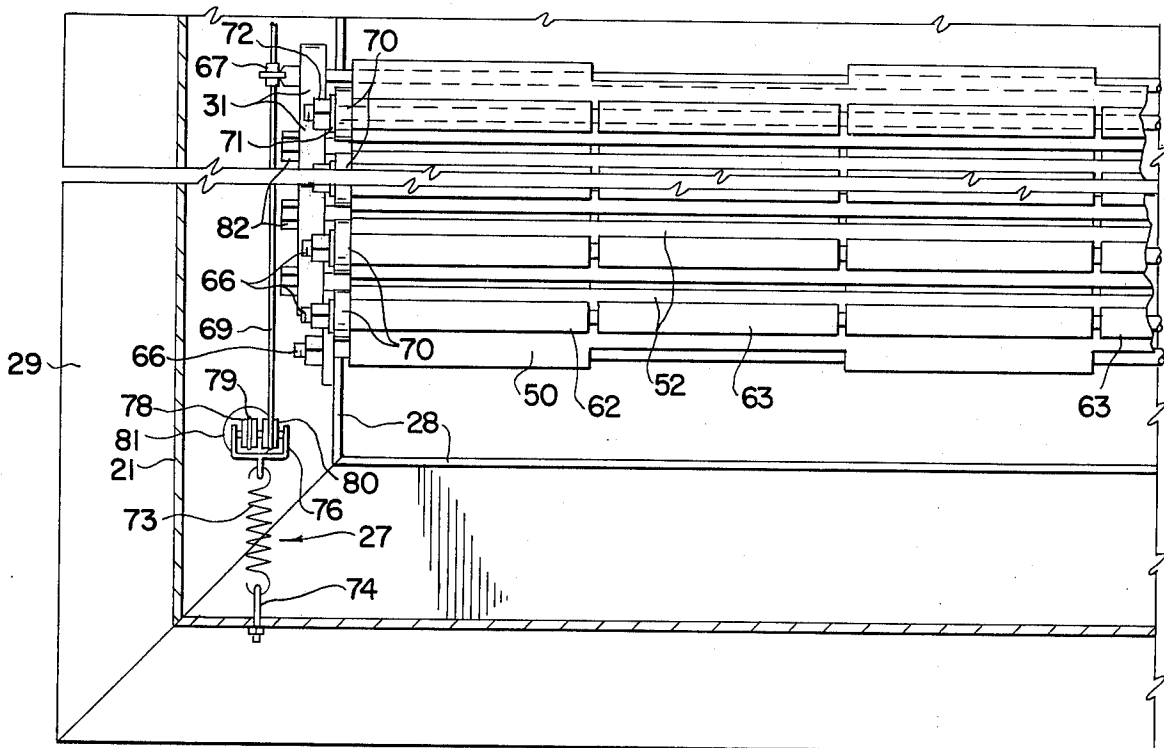

FIG. 5



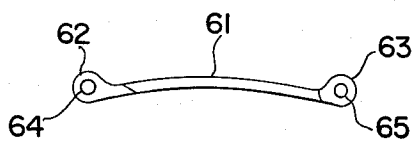

FIG. 6

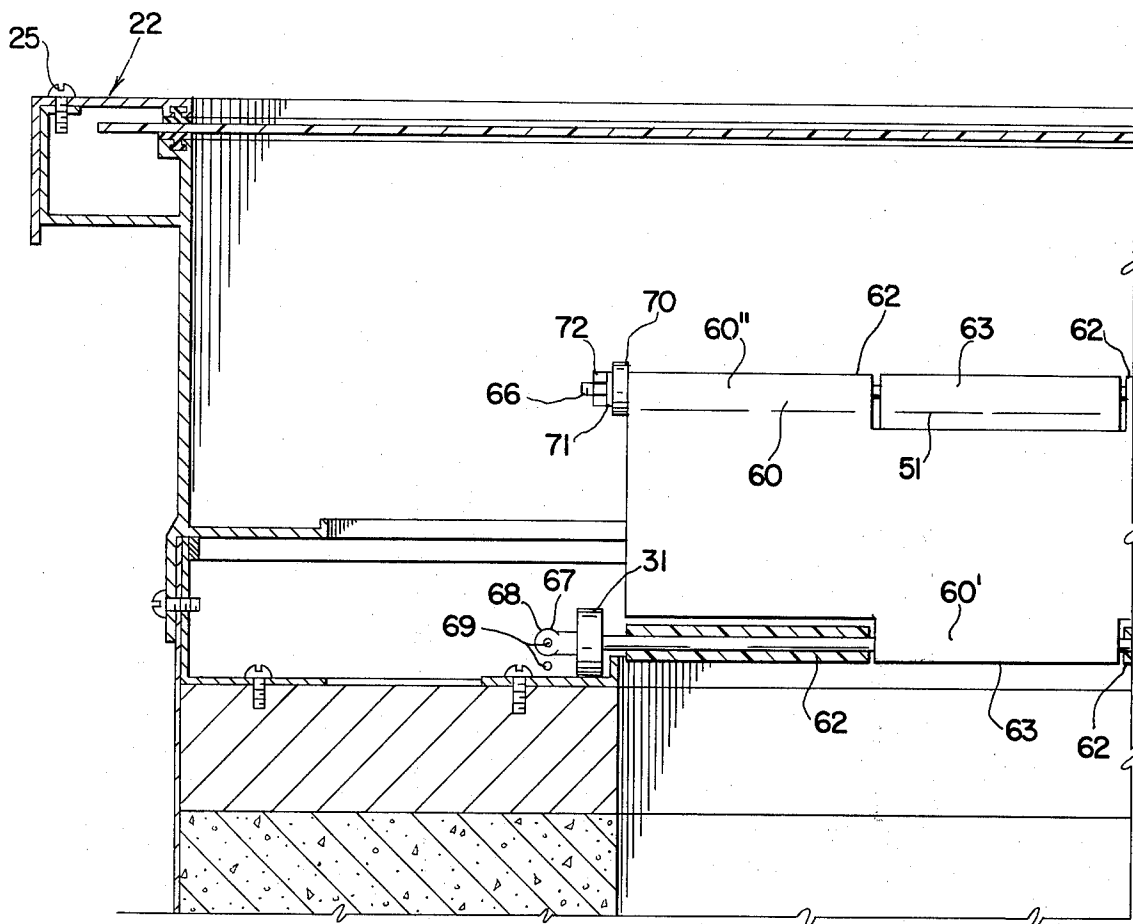
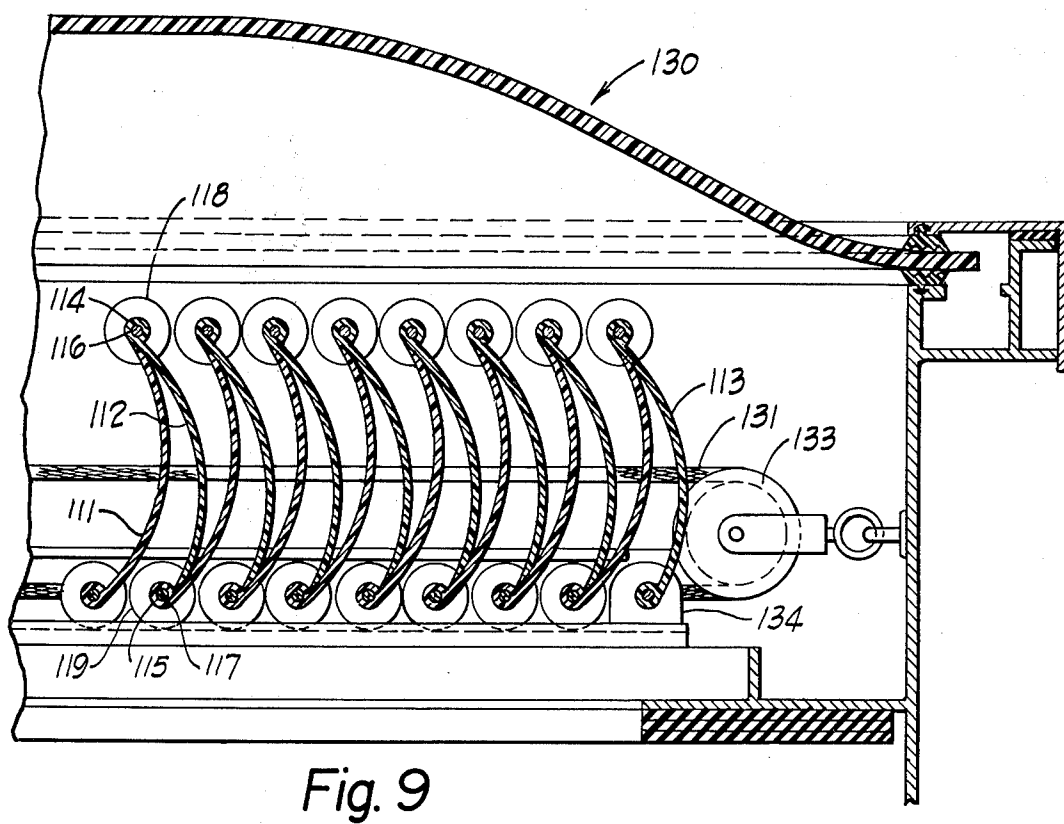
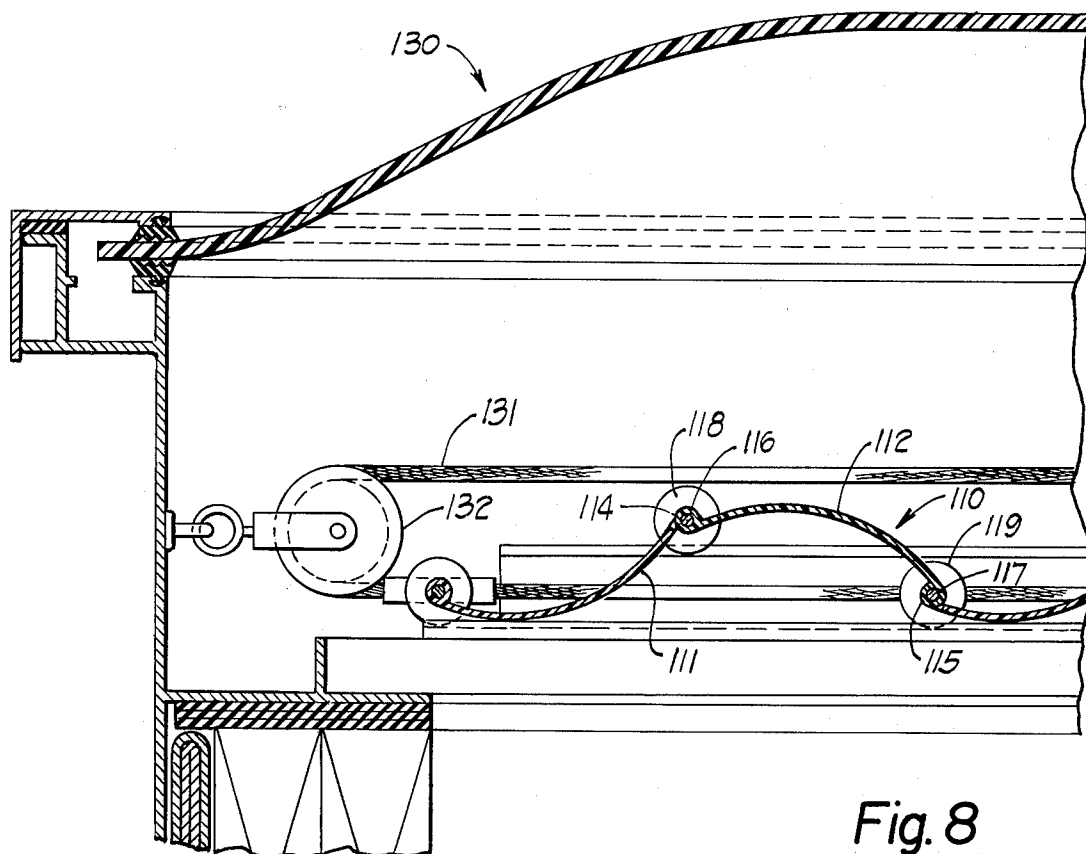

FIG. 7



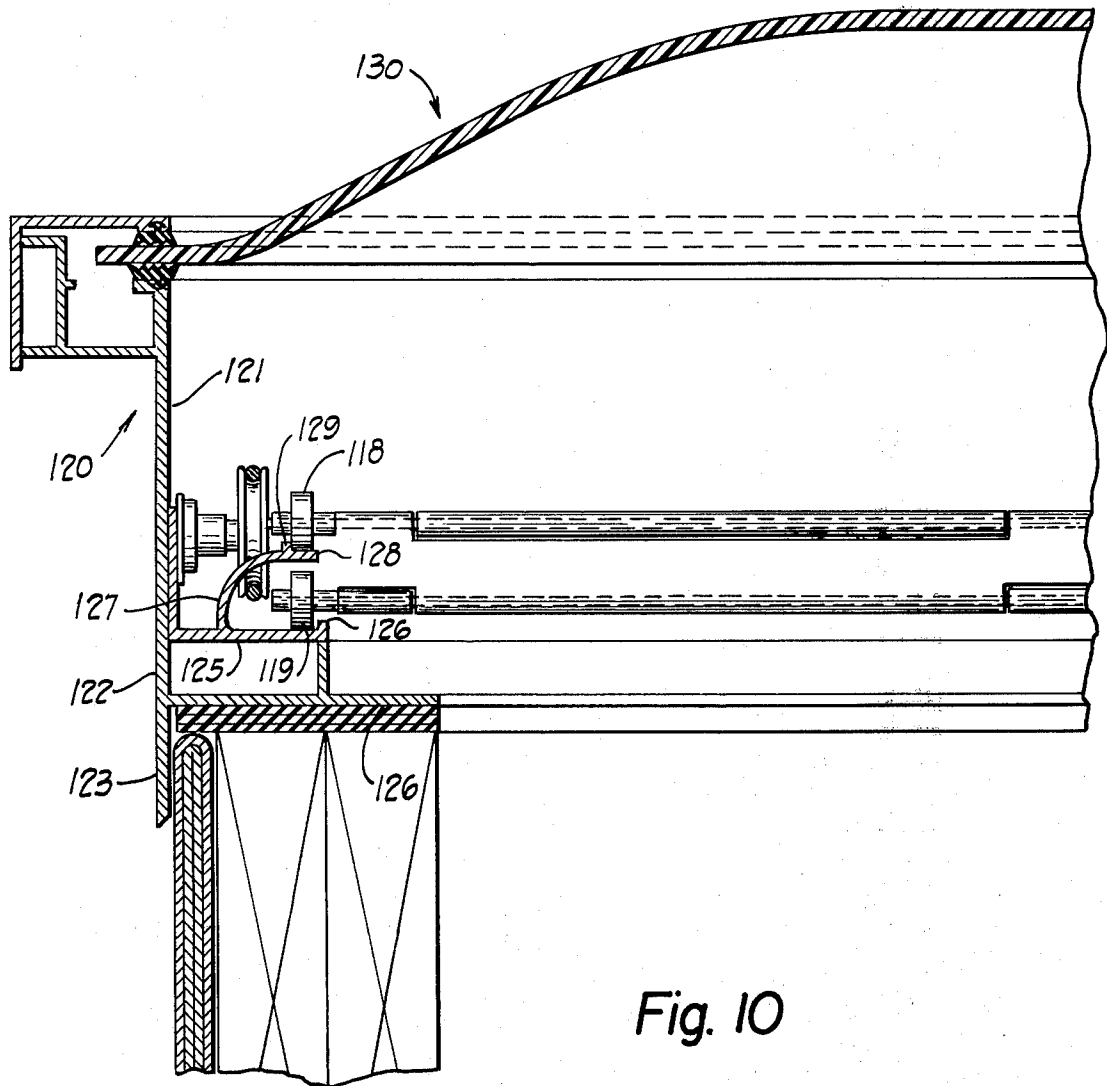

Fig. 10

## FOLDING SCREEN FOR LIGHT PERMEABLE SKYLIGHTS AND THE LIKE

### CROSS REFERENCE TO RELATED APPLICATIONS

This patent application is a continuation-in-part application of Ser. No. 462,172 filed Apr. 18, 1974 which in turn is a continuation application of Ser. No. 242,649 filed Apr. 10, 1972.

### BACKGROUND OF THE INVENTION

This invention relates to a folding, horizontally disposed screen, useful in conjunction with transparent and translucent skylights and roof panels of various types, through which heat generated by the sun's rays and sunlight particularly in the range from about the near-infrared to about the near-ultra-violet regions, may be controlled. Until recently, the problem of controlling sunlight and heat transmitted through roof structures has been of interest mostly in green houses where the optimum growth of plants is governed by the skilled control of the intensity of light to which they are exposed. In other applications, such as those in which skylights are used for dwellings, office buildings, and the like, the problem has been relatively less pressing, if only for the reason that the popularity of skylights, and other transparent and translucent building roof-structures, has acquired momentum only in recent years.

The present ready availability, at reasonable cost, of relatively large transparent planar and arcuate sections, generally referred to as "bubbles", has increasingly prompted builders to use relatively large expanses of bubbles to provide a functional roof-structure open to the sky. Thus, bubbles formed from synthetic, resinous, plastic materials, as well as from glass and fiberglass laminates, are increasingly used in modern residential and office buildings, including commercial installations for stadium roofs, service station island canopies, swimming pool enclosures, and the like. Mushrooming popularity of bubbles and light-transmitting roof structures has created a demand for an effective, easy to operate, and reliable radiation screen. Above all, a radiation screen useful in such an application must be as functional as it is compatible with the design and construction of the roof structure. The radiation screen of this invention is directed to satisfying that demand.

### SUMMARY OF THE INVENTION

The present radiation screen is directed for use in conjunction with parallel, horizontal overhead tracks disposed beneath a skylight or other transparent or translucent roof structure. It is a folding screen formed of a plurality of hinged, elongated, rigid, light-controlling panels supported in the overhead tracks. The panels may be stacked in a generally vertical, collapsed structure, or extended into a generally horizontal, planar structure beneath the skylight to control the amount of radiation which passes from the skylight to the area below the screen. One end panel adjacent one end of the tracks is fixedly disposed for pivotal movement about a longitudinal edge and the lead panel is connected to a flexible cable or similar drive means, preferably in a closed loop, which is subjected to sufficient force either to pull the screen into an extended position between one end of the tracks and the other, or to pull the screen in a stacked, collapsed position. Where the bubbles or skylights are inclined

from the horizontal, the radiation screen may be supported in overhead tracks inclinedly disposed beneath the light-permeable sections. In a specific embodiment, a radiation screen formed of plural, hinged, connected, rigid, light-controlling panels is supported for translation at an angle less than about 75° from the horizontal, in overhead tracks integral with the support structure for roof skylights. Hinges of all panels are provided with roller means at each end, which roller means permit to-and-fro translation of the panels in the tracks when actuated by a pull-cable.

Since rigidity of the panels is essential, the elongated panels are stiffened. Stiffness or rigidity may be imparted by ribs along the length or across either the top or the bottom surface of the panels. More preferably, rigidity may be obtained by providing a gentle arc to a panel by displacing the longitudinal edges of each panel downwardly with respect to the longitudinal axis along the upper surface of the panel. In other words, viewed from beneath, each panel is arcuate, being concave along its length. In one embodiment, plural, arcuate panels, collapsed in hinged, side-by-side relationship, present in end view, a compact profile of upstanding wishbones. In another embodiment the collapsed screen presents a serrated profile which is even more compact. Rigidity of the panels is enhanced by relatively thickened ribs at the longitudinal edges of the panels. The ribs are discontinuous and are provided with an axial, horizontal bore; the discontinuities of a discontinuous rib are adapted to accommodate a corresponding, juxtapositioned, discontinuous rib of an adjacent panel in a manner so as to permit a rod to be journaled therethrough. Interlocking ribs of adjacent panels, with the rod journaled therein, form a succession of hinges. In one embodiment of the invention each alternate rod is provided with a roller at each end, the remaining rods being provided with a washer at each end. In another embodiment all the rods are provided with a roller at each end. Each of the overhead tracks is especially adapted to permit translation of the panels, supported as described hereinafter, on the tracks.

In the illustration described, a folding radiation screen is provided beneath a transparent bubble of a plastic material such as methyl-methacrylate or the like. The edges of the bubble are fixedly disposed upon a horizontal support beam provided with an integral track in which the rollers on one side of the radiation screen are guided.

### BRIEF DESCRIPTION OF THE DRAWINGS

FIG. 1 is a front elevational view of a rectangular bubble skylight;

FIG. 2 is an enlarged side elevational view along the line 2—2 in FIG. 1 showing the support column on which the rectangular bubble is disposed, and a radiation screen in a collapsed or closed position, supported in a track which is an integral part of the support beam;

FIG. 3 is a side elevational view diagrammatically illustrating the radiation screen which is partially extended in a horizontal, planar attitude, and partially in a collapsed position;

FIG. 4 is a side sectional view along the line 4—4 in FIG. 2 with portions broken away to show details of construction;

FIG. 5 is a plan view, partially broken away, along the broken plane 5—5 in FIG. 4;

FIG. 6 is an end elevational view of an individual panel; and

FIG. 7 is a side sectional view with portions broken away showing the lead panel and the next preceding panel, and details of an installation of the instant folding screen in an existing structure having a light-permeable roof;

FIG. 8 is an elevational view similar to that shown in FIG. 2, of another embodiment of the invention showing the screen in an open or extended position in a bi-level overhead track;

FIG. 9 is an elevational view similar to that shown in FIG. 2, of the embodiment shown in FIG. 8, diagrammatically illustrating the radiation screen in a collapsed position;

FIG. 10 is a side sectional view, similar to FIG. 4, with a portion broken away, to show details of the embodiment shown in FIGS. 8 and 9, and particularly the bi-level track.

#### DETAILED DESCRIPTION OF THE INVENTION

Referring to the drawings, FIG. 1-7, which illustrate one embodiment of the invention, FIG. 1 shows a large rectangular bubble skylight shown generally as 10, removably clamped on a horizontal support beam, shown generally as 20, disposed upon an upstanding wall 40. Similar support beams are horizontally disposed beneath each outer edge of a bubble. Where plural bubbles are used in side-by-side relationship to form a "bubble-roof", suitable intermediate support beams, not necessarily of the same configuration as the support beams to be used also to support a foldable radiant screen, may be used. Where a large expanse of light-transmitting roof, such as a roof for a concert hall, sports arena, or the like is to be screen, plural screens in generally side-by-side relationship may be used, suitably supported either on support beams with integral guiding tracks or on guiding tracks alone, where support of the roof-structure is effected by other means, not in combination with a folding radiant screen.

As is shown in FIG. 2, the rectangular bubble 10 includes flanged edge 12 adapted to be clamped between suitably gasketed members of the horizontal support beam 20, as will be described hereinafter. The support beam 20 includes a lower support section, referred to generally as 21, and an upper clamping section 22. The upper section 22 is a generally rectangular L-shaped elongated section, with a thickened section near one edge suitably adapted to secure a gasket 23 in a position directly above the flanged edge 12 of the bubble. The upper section 22 is adapted to be disposed exteriorly of a protruding J-shaped section 24 on the outside of the lower support section 21 and on the upper portion thereof, so as to permit the member 22 to be clampingly secured upon the edge 12 by a fastening means such as a screw 25. The edge 12 of the bubble 10 rests upon a gasket 26 removably secured on top of the web of the lower support section 21. The gasket 26 is removably disposed in an inverted T-shaped slot provided in the top of the lower support section 21. The base of the lower support section 21 includes a horizontal track 27 provided with a vertical guiding lip 28, the track 27 being disposed interiorly of the support section 21. Disposed exteriorly of the support section 21, the base includes a down-turned flange section 29 adapted to snugly fit the outside upper corner of the wall 40. Disposed above the track 27 and inclinedly protruding interiorly from the support section 21 is a condensate gutter 30. The entire lower support section 21, including the J-shaped section 24, the track 27, the

down-turned flange 29 and the condensate gutter 30 are preferably formed as a single extrudate of aluminum. Where separate support beams are used for the roof structure; or in the case of pre-existing light-transmitting structures, channel guides may be used separately to provide suitably disposed tracks for the screen.

It will be apparent from the foregoing particular description that where, as in new construction, the specially adapted two-part support beam 20 of this invention is used, the edge 12 of the bubble 10 is securely clamped between the gaskets 23 and 26 which provide a fluid-tight seal. The seal is maintained by securing the clamping section 22 to the J-shaped section 24 by any suitable means such as plural metal screws 25.

Referring further to FIG. 2, and to FIG. 5 as required, the folding radiation screen of this invention includes a pivot panel 50 and a lead panel 51 connected by a series of intermediate panels 52, all shown in a vertically upstanding, stacked or collapsed position. The vertical panels 50-52 are successively connected together for side-by-side coaction by hinges 60 arranged successively on opposite sides of the panels. The panels are maintained in stacked, vertical relationship by a biasing force exerted by spring means such as a spring 73, one end of which is hooked into an eye bolt 74 fixedly disposed in the lower support section 21, near its base. The other end of the spring 73 is hooked into a lug 75 which is part of a pulley yoke 76. The spring constant of the spring 73 is such that it exerts sufficient force to take up any slack in a driven cable 69 which may normally be expected to result from repeated opening and closing of the screen over an extended period of time. It will be recognized that where the screen is to extend longitudinally over a relatively long distance, a slight extension or contraction of a metal cable cannot be disregarded. Where it is practical to use other drive means, such as a chain, to translate the panels from a stacked relationship to an extended, generally planar relationship, the biasing means may be dispensed with.

The pulley yoke 76 has a pin 77 journaled in the arms of the yoke. A drive pulley 78 and a driven pulley 80 are fixedly disposed in side-by-side relationship on the pin 77. The pulleys 78 and 80 are preferably grooved to accommodate a drive cable 79 and the driven cable 69. The drive cable 79 hangs downwardly through an aperture 81 provided in the track 27 and is preferably looped around an idler pulley (not shown) as is conventionally done, where manual operation of the drive cable is desired. Power drive means also may be conveniently adapted to drive the drive cable 79. As diagrammatically illustrated in FIG. 5, the driven cable 69 is fixedly attached to a flared guide 67 on a lead wheel 31 of a lead panel 51. Reverting to FIG. 2, it is seen that the cable 69 thereafter is passed over an idler pulley (not shown) and returned so as to form a closed loop to open and close the folded screen. In the embodiment described herein, a drive cable and driven cable provided on one side of the screen, is sufficient to translate it in its tracks. Where relatively long panels are used, as for example, where each panel is in excess of 8 feet long, it may be desirable to provide a dual cable system, properly synchronized to extend or collapse the screen without jamming it in its tracks.

Each of the intermediate panels 52 are supported on intermediate wheels 32 which ride on the track 27. The intermediate wheels 32 are secured on rods 66 of alternate hinges so as to align all the wheels 32 and 31, and



the alignment is maintained by providing nuts 82 for each wheel in such a way as not to interfere with the operation of the driven cable 69.

As shown in FIGS. 3 and 4, each hinge 60 is formed by the rod 66 journaled in mating discontinuous sections of ribs of adjacent panels. Referring now to the lower hinge 60, referred to as 60' in FIG. 4, it is seen that the rod 66 clears the vertical lip 28 on the inside edge of the track 27. The wheel 31 on the lead panel 51 is rotatably disposed near the end of the rod 66 and is supported by the track 27 for rolling translation thereupon. The end of the rod 66 protruding through the wheel 31 is provided with a flared guide 67 having a passage 68 through which a cable 69 may be threaded but which is fixedly disposed with respect to the guide 67 at the passage 68. Referring now to the upper hinge 60, referred to as 60'' in FIG. 4, the rod 66 is provided at each end with a washer 70 abuttingly secured against the ends of the mating ribs 62 and 63 by a lock washer 71 and a nut 72. The dimensions of the washer 70 are so chosen that, when the radiant screen is extended or "opened", the washer 70 is peripherally supported against the upper edge of the lip 28 maintaining the rods 66 of the hinges 60'' in a generally horizontal plane. It will be recognized that, were the rod 66 in a hinge 60'' to fall below the horizontal plane defined by the rods 66 in the hinges 60' in the open position, the radiant screen could not be closed, that is, returned to its stacked position by a pulling action on the lead panel 51 to which the cable 69 is secured. The relationship of the axis of the washers 70, slightly vertically displaced upwardly from the line connecting the axes of the wheels 31 and 32, is critical to permit collapsing of the screen. The arcuate shape of each panel 50-52, described hereinbelow, is a simple and easy way to impart longitudinal rigidity to the panels to facilitate operation of the screen.

As is shown in FIGS. 2 and 3, the pivot panel 50 is pivotally disposed about a rod 66 journaled in brackets 90 fixedly disposed adjacent each end of the overhead tracks 27. It will be recognized that each track 27 on each side of the screen supports intermediate wheels 32 and a lead wheel 31 rotatably disposed on rods 66 of alternate hinges 60 so that one end of each panel, on each side of the screen, is supported for rolling translation. Generally, a screen will extend longitudinally beneath the full length of the skylight. In a fully collapsed position, the screen will permit all the radiant energy, both heat and light, to enter the enclosed structure. In a fully extended position, depending on the choice of the light-permeability of the panels of the screen, the heat and light energy of the radiation through the skylight is screened out to the extent desired. It will be apparent that the width of individual panels and the length of the light-permeable roof structure will determine the number of panels required to furnish a screen adequate for the entire length. Where desirable, the folding screen may also be partially extended, leaving some panels stacked and distending others to provide a screen.

It is seen, that to open the radiant screen, that is, to extend the partitions from a stacked position to a generally horizontal, planar position, a pulling action on the lead panel 51 by the cable 69 will sequentially unfold the panels 50-52 as the wheels 31 are rollingly translated along the track 27 and alternate hinges 60'' of those panels in the open position will, because of the washer 70, come to rest in a position which will facili-

tate the re-stacking of the panels by a pulling action on the cable 69 in a direction opposite to that required to extend the panels from a vertical stacked relationship.

As is shown in FIG. 6, each panel comprises an arcuate, elongated strip 61 bounded at its edges by thickened, longitudinally extending ribs 62 and 63, each provided with an axial bore for its entire length. The ribs 62 and 63 are discontinuous to provide a hinge between adjacent panels when a rod 66 (FIGS. 2-5) is journaled therein. The strip and ribs of each panel are preferably extruded together from a suitable plastic material such as methyl-methacrylate or other acrylic ester. The discontinuities or "notches" in each rib may be provided by shearing sections of each rib so as to permit discontinuous ribs of adjacent panels to be interdigitated to form a hinge when the rod 66 is journaled in their aligned axial bores. Alternatively, the arcuate strip may be extruded or shaped by pressing, vacuum forming or the like, and the ribs 62 and 63 affixed to the edges by solvent welding, sonic welding or other known methods. Fixing the ribs on to pre-formed strips is advantageous where relatively short ribs will provide adequate hinging action and support; but short ribs may require the edges of the strips to be "stepped" to preclude undesirably wide open slots between successive panels when the folding screen is fully extended.

The length and width of each panel is limited only by practical considerations. For example, very long panels tend to "sag" in the center and interfere with the smooth operation of the hinges. The deflection of long panels may be overcome by increasing their rigidity either by making them more arcuate, by providing additional stiffening ribs or by utilizing a thicker cross-section of panel. It will be apparent that each of the methods of increasing the rigidity presents certain disadvantages with respect both to collapsing the screen tightly as well as to economic feasibility. The width of the panels will be determined, inter alia, by the space available beneath the bubble, which in a new structure utilizing the support beam 20 with integral, horizontal tracks 27 of this invention, will depend upon the height of the lower section 21 of the support beam 20. A convenient width of a strip for a panel particularly suited to an essentially maintenance-free radiant screen, is in the range from about 3 to about 12 inches and a length from about 4 to about 16 feet. Thickness of each strip is in the range from about 0.0625 inch to about 0.375 inch. The ribs 62 and 63 may be conveniently formed with a nominal or effective diameter in the range from about 0.1875 inch to about 0.5 inch. It will be recognized that, where the width and length of a panel is such as to provide sufficient rigidity without necessitating an arcuate strip a flat, elongated strip may be used.

The materials from which panels of predetermined radiation permeability may be made are not limited to extruded plastic materials. The panels may be made of translucent fiberglass reinforced plastic panels or from tinted glass. However, the ease with which glass may be extruded, formed and tinted is offset by the difficulty of handling it. By predetermined radiation permeability is meant a preselected, desirable characteristic of the material from which the panel is formed, both with respect to the intensity and the range of wave lengths of heat and light radiation to which the panel is permeable.

As has been mentioned hereinabove, the folding radiation screen of the instant invention may be used in existing structures with light-permeable roofs. A partial section of a flat, light permeable bubble, as installed in

an existing structure, is shown in FIG. 7 and includes a sheet of tinted plastic material 10a clamped in a prior art support beam 20a. The upper portion of the support beam 20a is identical with the upper portion of the support beam 20. The lower portion of the beam 20a is provided with a gutter 30a and a downwardly turned flange section 11 at its base adapted to engage the up-standing side of the right angle member 13. The angle 13 is fixedly disposed upon the wall 40a which is normally wide enough to accommodate an L-shaped section 14 coextensively disposed with respect to the angle 13. The L-shaped section is fixedly secured to the top of the wall 40a as shown in FIG. 7 so as to provide a horizontal track in which the wheels 31 and 32 may be translatably, rotatably disposed. The opposite wall is similarly provided with an L-shaped section 14 so as to provide a pair of oppositely disposed tracks, in a horizontal plane, in which the radiation screen may be disposed. As described hereinbefore, a drive cable and driven cable, biased to take up variations in length of the loop of driven cable, are provided to operate the screen.

In those instances where the span of the area to be screened is such as to make the length of a single panel impractical, that is, the width of a folding screen such as to interfere with the operation of the hinges, plural screens may be used in side-by-side relationship, each operable independently of an adjacent screen. Where, as for example, in a pre-existing structure, two coplanar folding screens are to be used, the outside edges of the screens are supported in L-shaped track sections 14 and the inside edges of each screen are supported in a channel section suspended from the roof structure. The channel section provides side-by-side tracks for the wheels 31 and 32 on the inside edges of the screens.

As has been mentioned hereinabove, the radiation screen may be installed in inclinedly disposed tracks. It will be apparent that the driven cable may be adapted to exert sufficient frictional force on the track-guide wheels 32 and 31 so as to permit the screen to remain in an extended, or partially extended position, though it may be inclinedly disposed. The precise extent to which the frictional forces on the wheels may be controlled may be varied by increasing the number of flared guides to which the driven cable is threaded; for example, maximum frictional force will be provided by threading the cable through successive flared guides. A lesser frictional force may be obtained by threading the cable through flared guides disposed on every alternate rod carrying a wheel. Even fewer flared guides may suffice where the angle of inclination is small, that is, in the range from 15° to 30°. Additionally, wheels which have relatively greater friction coefficients with respect to the rods on which they are disposed may be used to minimize the tendency of the screen to collapse from an extended, upwardly inclined position. Other means for increasing the friction to overcome the tendency of the screen to collapse in its inclined tracks due to its weight will be apparent to those skilled in the art. Depending upon the choice of frictional engagement of successive panels on the radiation screen, the tracks in which the screen is disposed may be inclined from the horizontal at any angle less than about 75°. More preferably, the screen is used at angles inclined from the horizontal which are less than 45°. It will be apparent that the physical dimensions of the skylight under which the radiation screen is to be disposed, the number of screens to be used in side-by-side relationship,

the width of the skylight and the length of each screen will all be factors in determining the practical limits of the inclination of the tracks in which the screen may operate.

Though in most instances where a screen is to be inclinedly disposed, it will be extensible upwardly, in some instances, it may be desirable to have an inclinedly disposed screen which is extensible downwardly, that is, the screen may be extended essentially under its own weight but must be collapsed by returning the panels into their stacked relationship by collapsing the screen, overcoming the downward component of its weight in the tracks.

In another second embodiment of the invention illustrated in FIGS. 8-10 the folding screen may be stored more compactly by a different disposition of the arcuate panels in hinged relationship with each other. This second embodiment also provides for translation of the panels in a unique by-level track. In the description hereinafter reference will be made only to the details necessary to distinguish this second embodiment from the first one, since other details as to operation will be apparent from the foregoing description of the first.

Referring now particularly to FIG. 8 there is shown a side elevation, with a portion broken away, of a folding screen indicated generally by the reference numeral 110 having a lead panel 111, intermediate panels 112 and pivot panel 113 (see FIG. 9). As will be evident, each panel comprises an arcuate elongate strip bounded at its edges by thickened discontinuous ribs having an axial bore therethrough, as described hereinbefore, so that adjacent panels may be interdigitated and hinged at upper hinges 114 and at lower hinges 115. With this arrangement every other panel is concave upwards, the remaining panels being concave downwards, and as will be seen in FIG. 9, the collapsed screen is more compact than the screen with all panels concave downwards.

Each upper hinge 114 has an upper hinge rod 116 journaled in the interdigitated ribs of adjacent panels, and each lower hinge 115 has a lower hinge rod 117 similarly journaled. Each upper hinge rod 116 has an upper roller 118 rotatably mounted near each end of the rod 116, and each lower hinge rod 117 has a lower roller 119 rotatably mounted near each end of the rod 117. The lower rollers 119 are always supported but the upper rollers are not supported when the screen is in the closed position; only some of the upper rollers are supported when the screen is partially open; and all the upper rollers are supported when the screen is fully extended, as will be better understood from the following description of the support means in which the rollers are translated. The rollers reduce friction and are preferred. It will be evident that where the friction to be overcome in opening and closing the screen is not a factor, or where substantial friction is desired, the rollers may be replaced with any suitable translatable supports such as pads or spacers fixedly disposed at the ends of the hinge rods.

Referring now to FIG. 10 in particular, there is shown a support beam indicated generally by reference numeral 120, for the screen 110, which support beam also supports the plastic bubble indicated generally by reference numeral 130. The support beam 120 has a web 121 the lower portion of which includes a box section 122. Flanges 123 and 124 are normally disposed relative to one another and protrude from the box section 122 so the flanges rest on a supporting wall of the struc-

ture covered by the plastic bubble 130. The upper horizontal side 125 of the box section 122 serves as the lower level support upon which the lower rollers 119 all translated, and terminates in a lower guide lip 126. Intermediate the guide lip 126 and the web 121, an arcuate member 127 projects above the lower roller 119 and terminates in a horizontal ledge 128 which serves as the upper level support upon which the upper rollers 118 are translated. An upper guide lip 129 on the upper level limits lateral movement of the upper rollers 118.

A similar support means is provided for the oppositely disposed side of the screen. As described in the first embodiment, where the span under the bubble is large, it may be desirable to provide an intermediate bi-level track in which the rollers are translatable. As also described hereinbefore, suitable pulleys and drive cables, previously used, are operatively connected to the lead panel 111 of the screen as diagrammatically illustrated herein, so that pulling on the lead panel progressively moves the upper rollers 118 into rolling engagement with the horizontal ledge or upper level of the bi-level tracks.

For example, a drive cable 131 may be drivingly trained upon a pulley 132 and attached to the leading edge of the folding screen to enable the screen to be extended and collapsed by exerting a force on the lead panel. Thus, it will be appreciated that the lead panel and the next adjacent panel are extended or collapsed first, with the remaining panels successively performing the same movement. The screen may thus be partially extended, the remaining portion remaining in a collapsed position. The pulley 132 may be affixed to a structural member as shown in FIG. 8. A second pulley 133 is similarly affixed at the opposite end of the screen adjacent the pivot panel 113 as shown in FIG. 10. The drive cable 131 is drivingly trained upon the pulley and anchored to the support 134 in which a pivot rod for the pivot panel is journaled. It will be evident that the length of the loop defined by the drive cable 131 and the folding screen 110 will vary depending upon the extent to which the screen is extended. When the screen is fully extended, there is maximum slack in the drive cable, and all upper rollers 118 are supported on the upper level of the bi-level track. It is desirable, particularly for motor-driven operation of the screen, that a take-up loop be provided for such slack as does occur depending upon the position of the screen, and this take-up may be effected by any means such as are well known in the art.

The scope of the invention is not limited to the slavish imitation of all of the structural and operative details mentioned above. These have been given merely by way of an example of a presently preferred embodiment of the invention. For example, though rolling means have been described for the obvious reason that in most installations, rolling friction is preferable, it will be apparent that the wheels in the tracks may be replaced by pads which are slidably disposed in tracks.

I claim:

1. A folding radiation screen having predetermined permeability to sunlight, for operation beneath a skylight or light-permeable roof structure, said screen comprising a plurality of relatively rigid panels succes-

sively hinged together through interdigitated longitudinal edges thereof for co-action in side-by-side relationship and supported by a pair of parallel, overhead track means inclinedly disposed at an angle less than 75° with respect to the horizontal, each said track means including a lower horizontal track and an immovable vertical guiding lip means, said panels being movable from a folded, stacked relationship adjacent one end of said track means to a generally planar relationship extending between said one end and the other end of said track means, the end panel adjacent said one end being fixedly disposed for pivotal movement about the longitudinal edge of said end panel adjacent said one end; rolling means supported by said lower horizontal track, and, washer or spacer means supported by said lip means to coaxingly translate said panels along said tracks so as to dispose hinged edges supported by said lip means in a plane vertically upwardly displaced relative to a plane including hinged edges supported by said rolling means; and, flexible means to exert a sufficient force on said panels, in either direction along said tracks, to translate said panels from said stacked relationship into said generally planar relationship, or vice versa, so as to control the intensity of said sunlight below said screen.

2. The folding screen of claim 1 wherein said panels are arcuate, the curvature of each panel being such that a line parallel to the longitudinal axis of each panel and on the surface thereof, is vertically displaced with respect to the longitudinal edges of each panel.

3. A folding radiation screen having predetermined permeability to sunlight, for operation beneath a skylight or light-permeable roof structure, said screen comprising a plurality of relatively rigid panels successively hinged together through interdigitated longitudinal edges thereof for co-action in side-by-side relationship and supported by a pair of parallel, overhead bi-level track means inclinedly disposed at an angle less than 75° with respect to the horizontal, each said track means including an upper level track and a lower level track, said panels being movable from a folded, stacked relationship adjacent one end of said track means, to a generally planar relationship extending between said one end and the other end of said track means, the end panel adjacent said one end being fixedly disposed for pivotal movement about the longitudinal edge of said end panel adjacent said one end; upper roller means supported by said upper level track, and lower roller means supported by said lower level track to coaxingly translate said panels along said tracks so as to dispose upper hinges of said screen in a plane vertically upwardly displaced relative to a plane including lower hinges of said screen; and, flexible means to exert sufficient force on said panels, in either direction along said tracks, to translate said panels from said stacked relationship into said generally planar relationship, or vice versa, so as to control the intensity of said sunlight below said screen.

4. The folding screen of claim 3 wherein said panels are arcuate and successively hinged together with a downwardly concave panel adjacent an upwardly concave panel.

\* \* \* \* \*