

(19)



(11)

**EP 2 048 107 A1**

(12)

**EUROPEAN PATENT APPLICATION**

(43) Date of publication:  
**15.04.2009 Bulletin 2009/16**

(51) Int Cl.:  
**B66F 7/08 (2006.01) B66F 7/26 (2006.01)**  
**B25H 1/00 (2006.01)**

(21) Application number: **07075875.0**

(22) Date of filing: **09.10.2007**

(84) Designated Contracting States:  
**AT BE BG CH CY CZ DE DK EE ES FI FR GB GR HU IE IS IT LI LT LU LV MC MT NL PL PT RO SE SI SK TR**  
Designated Extension States:  
**AL BA HR MK RS**

(72) Inventors:  
• **De Lange, Jan**  
**7533 BD Enschede (NL)**  
• **Oliveri, Agostino**  
**7522 ET Enschede (NL)**

(71) Applicants:  
• **De Lange, Jan**  
**7533 BD Enschede (NL)**  
• **Oliveri, Agostino**  
**7522 ET Enschede (NL)**

(74) Representative: **'t Jong, Bastiaan Jacob et al**  
**Arnold & Siedsma**  
**Sweelinckplein 1**  
**2517 GK Den Haag (NL)**

(54) **Vehicle lift with a jack device**

(57) The invention relates to a vehicle lift, in particular for a motorcycle, which lift comprises a height adjustable plateau for supporting the vehicle,

a jack device is arranged to the plateau for lifting or supporting at least one wheel of the vehicle.

With the jack device it is possible to have a support surface for the wheel, independent of the plateau itself.

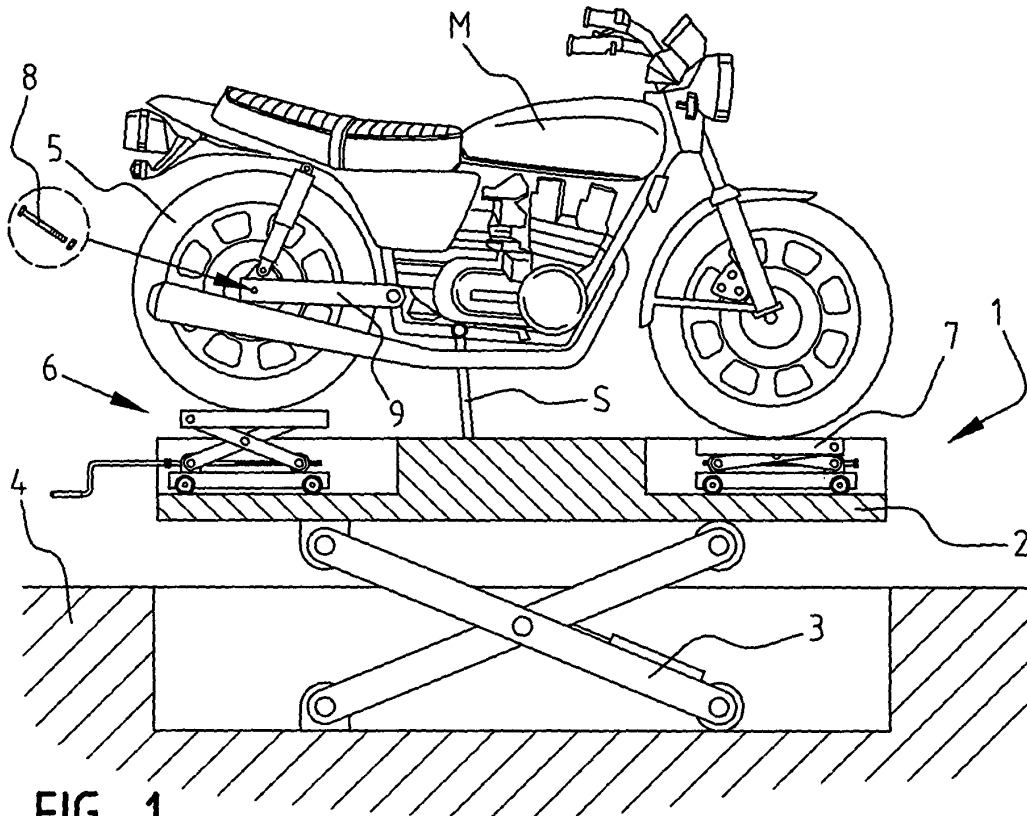

**FIG. 1**

**EP 2 048 107 A1**

## Description

[0001] Invention relates to a vehicle lift, in particular for a motorcycle, which lift comprises a height adjustable plateau for supporting the vehicle.

[0002] When maintaining a motorcycle it is common to place the motorcycle onto a vehicle lift and to lift the motorcycle to a height at which the mechanic can easily maintain the motorcycle. When changing a tyre of a motorcycle the motorcycle is put on its' stand such that the wheel is unsupported. Then a second mechanic will hold the wheel while the first mechanic removes the wheel axle with which the wheel is arranged into the frame of the motorcycle. The second mechanic then removes the wheel while supporting the wheel, which is heavy and not ergonomic.

[0003] Something similar applies for changing the tyre of a car. After removing the bolts or nuts from the wheel hub the wheel has to be lifted and removed from the wheel hub.

[0004] It is the object of the invention to provide a vehicle lift, which removes the above stated disadvantages or at least diminishes these disadvantages.

[0005] This object is achieved by a vehicle lift according to the invention, which is characterised in that a jack device is arranged to the plateau for lifting or supporting at least one wheel of the vehicle.

[0006] With this jack device it is possible to have a support surface for the wheel, independent of the plateau itself such that the wheel can be supported even when it is lifted off the plateau. For a motorcycle, the wheel is lifted off the plateau by putting the motorcycle on its' stand and then the jack device is set to support the lifted wheel. The mechanic removes the axle of the wheel, and as the wheel is supported by the jack device, the mechanic can easily take the wheel from the frame of the motorcycle.

[0007] In a preferred embodiment of the vehicle lift according to the invention, the jack device is displaceable in the plane of the plateau. As vehicles can differ in length and width it is preferable to be able to displace the jack device in the plane of the plateau in order to position the jack device under a wheel. This prevents the mechanic from having to precisely manoeuvre the vehicle onto the plateau such that the wheel is positioned above the jack device.

[0008] In another embodiment of the invention, the jack device comprises a scissors jack. Scissors jacks are simple in design, cost effective and provide a stable support for wheels.

[0009] In yet another embodiment, the jack device is hydraulic.

[0010] In a further preferred embodiment of the vehicle lift according to the invention, the upper surface of the jack device is sinkable into the upper surface of the plateau. In such a condition, the upper surface of the jack device is part of the plateau and the vehicle is easily arranged onto the plateau.

[0011] In another embodiment of the vehicle lift accord-

ing to the invention the plateau, in particular for a four-wheel vehicle, is provided with an elongate central opening. This enables the mechanic to inspect the bottom of the vehicle when placed on the plateau. Furthermore with a vehicle lift according to the invention, the jack device can comprise a support surface, which is displaceable between the positions substantially flush with the upper surface of the plateau and a position above and at a distance from the upper surface of the plateau.

[0012] The vehicle lift could also comprise a jack device having a support surface, which is displaceable between a position substantially flush with the upper surface of the plateau and the position below and at a distance from the upper surface of the plateau. In this latter embodiment the wheel of the vehicle can be suspended free in the air by bringing the jack device towards the position below and at a distance from the upper surface of the plateau.

[0013] These and other advantages of the invention will be illustrated in conjunction with the accompanying drawings.

Figure 1 shows a cross-sectional view of a vehicle lift according to the invention in which a jack device supports the rear wheel of a motorcycle.

Figure 2 shows the vehicle lift according to figure 1 in which the rear wheel of the motorcycle is removed from the frame by lowering the jack device.

[0014] Figure 1 shows a lift device 1 having a plateau 2 which is moveable up and down by a rod system 3. The rod system 3 is sunk into the floor 4 of for example a workshop.

[0015] A motorcycle M is placed on the plateau and stood on its' stand S. As a result the rear wheel 5 is in the air. A scissors jack 6 supports the wheel 5. This scissors jack 6 is displaceable onto the plateau 2 in longitudinal direction. A second scissors jack 7 is arranged under the front wheel.

[0016] When the axle bolt 8 is removed from the motorcycle frame 9, the rear wheel 5 will still be supported by the scissors jack 6.

[0017] As shown in figure 2 the rear wheel 5 can be removed from the frame 9 of the motorcycle M by lowering the scissors jack 6.

[0018] From this figure it is also clear that in this position the support surface 10 of the scissors jack 6 is flush with the upper surface 11 of the plateau 2.

## Claims

1. Vehicle lift, in particular for a motorcycle, which lift comprises a height adjustable plateau for supporting the vehicle, **characterized in that,** a jack device is arranged to the plateau for lifting or supporting at least one wheel of the vehicle.

2. Vehicle lift according to claim 1,  
**characterized in that,**  
the jack device is displaceable in the plane of the plateau.  
5
3. Vehicle lift according to claim 1 or 2,  
**characterized in that,**  
the jack device comprises a scissors jack.
4. Vehicle lift according to any of the preceding claims,  
**characterized in that,**  
the jack device is hydraulic. 10
5. Vehicle lift according to any of the preceding claims,  
**characterized in that,**  
the upper surface of the jack device is sinkable into  
the upper surface of the plateau. 15
6. Vehicle lift according to any of the preceding claims,  
**characterized in that,**  
the plateau, in particular for a four wheel vehicle, is  
provided with an elongate, central opening. 20
7. Vehicle lift according to any of the preceding claims,  
**characterized in that,**  
the jack device comprises a support surface, which  
is displaceable between a position substantially flush  
with the upper surface of the plateau and a position  
above and at a distance from the upper surface of  
the plateau. 25  
30
8. Vehicle lift according to any of the preceding claims,  
**characterized in that,**  
the jack device comprises a support surface, which  
is displaceable between a position substantially flush  
with the upper surface of the plateau and a position  
below and at a distance from the upper surface of  
the plateau. 35  
40  
45  
50  
55

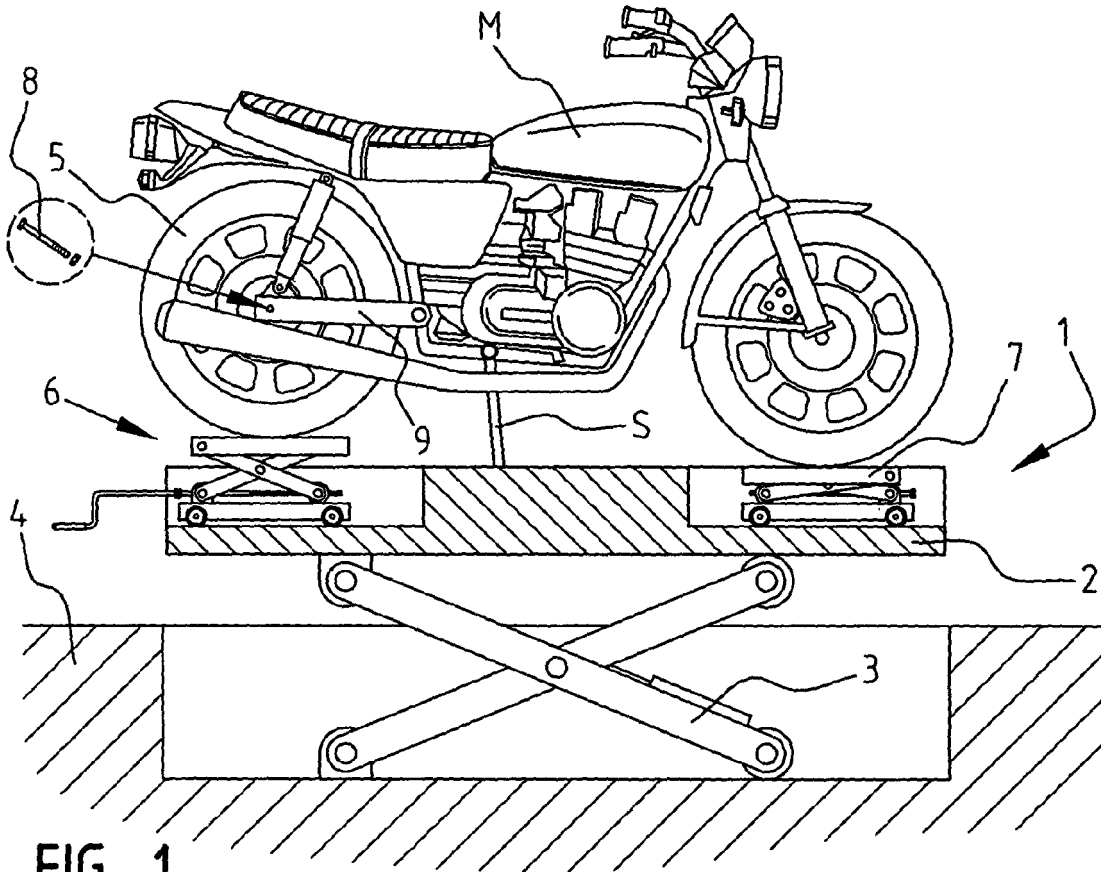

**FIG. 1**

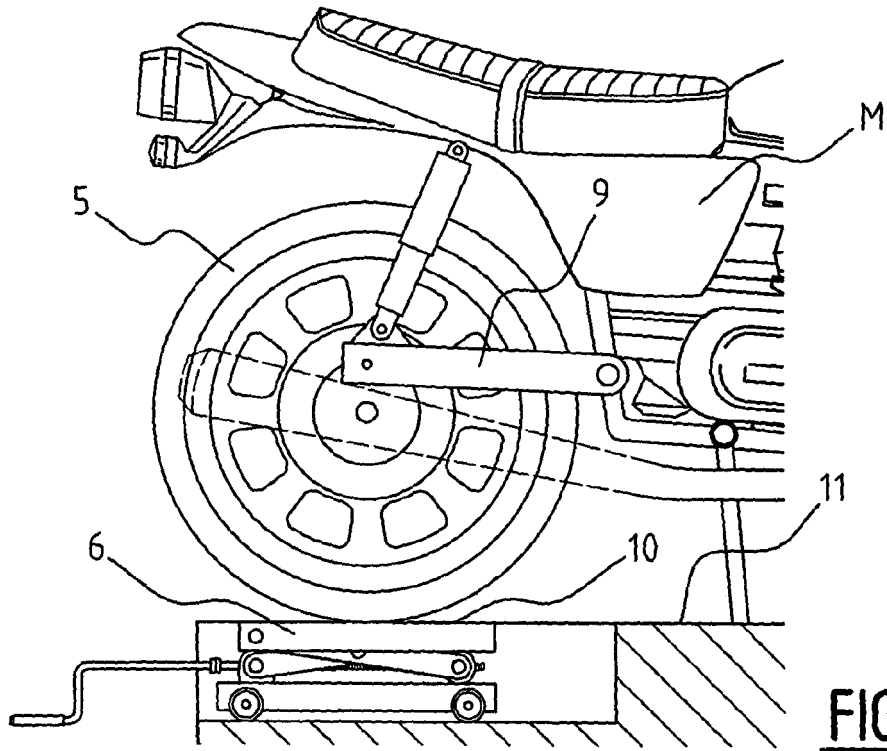

**FIG. 2**



DOCUMENTS CONSIDERED TO BE RELEVANT			
Category	Citation of document with indication, where appropriate, of relevant passages	Relevant to claim	CLASSIFICATION OF THE APPLICATION (IPC)
X	US 4 750 712 A (GENOVESE JOLANDA [IT]) 14 June 1988 (1988-06-14)	1,4-8	INV. B66F7/08 B66F7/26 B25H1/00
Y	* column 2, line 62 - column 3, line 4; figures 3,5 *	2,3	
Y	----- US 4 447 042 A (MASUI SABURO [JP]) 8 May 1984 (1984-05-08)	2	
Y	* column 2, line 50 - column 3, line 3; figures 5,6 *		
A	* column 3, line 41 - line 47 *		
Y	----- US 5 031 726 A (WAKAMIYA KOJI [JP]) 16 July 1991 (1991-07-16)	3	
A	* figures 1,2 *	1	
A	----- US 6 164 414 A (DUTY BILLY G [US]) 26 December 2000 (2000-12-26)	1	TECHNICAL FIELDS SEARCHED (IPC)  B66F B25H B62H
A	* column 7, paragraph 2; figures 1,2 *	1	
A	----- US 5 001 798 A (HAMILTON HAROLD F [US]) 26 March 1991 (1991-03-26)	1	
A	* column 3, line 39 - line 40; figure 1 *	1	
A	----- FR 2 666 254 A (CELETTE SA [FR]) 6 March 1992 (1992-03-06)	1	
A	* the whole document *	1	
A	----- DE 32 40 952 A1 (NUSSBAUM OTTO GMBH CO KG [DE]) 10 May 1984 (1984-05-10)	1	
	* abstract; figure 1 *		
-----			
The present search report has been drawn up for all claims			
Place of search <b>Munich</b>		Date of completion of the search <b>10 March 2008</b>	Examiner <b>Ferrien, Yann</b>
<b>CATEGORY OF CITED DOCUMENTS</b> X : particularly relevant if taken alone Y : particularly relevant if combined with another document of the same category A : technological background O : non-written disclosure P : intermediate document		T : theory or principle underlying the invention E : earlier patent document, but published on, or after the filing date D : document cited in the application L : document cited for other reasons ..... & : member of the same patent family, corresponding document	

1  
EPO FORM 1503 03.02 (P04C01)

ANNEX TO THE EUROPEAN SEARCH REPORT  
ON EUROPEAN PATENT APPLICATION NO.

EP 07 07 5875

This annex lists the patent family members relating to the patent documents cited in the above-mentioned European search report. The members are as contained in the European Patent Office EDP file on  
The European Patent Office is in no way liable for these particulars which are merely given for the purpose of information.

10-03-2008

Patent document cited in search report		Publication date	Patent family member(s)	Publication date
US 4750712	A	14-06-1988	NONE	
US 4447042	A	08-05-1984	JP 57166293 A	13-10-1982
US 5031726	A	16-07-1991	JP 2079392 U	19-06-1990
			JP 6050478 Y2	21-12-1994
			KR 960003408 Y1	23-04-1996
US 6164414	A	26-12-2000	NONE	
US 5001798	A	26-03-1991	NONE	
FR 2666254	A	06-03-1992	NONE	
DE 3240952	A1	10-05-1984	NONE	