

(No Model.)

2 Sheets—Sheet 1.

D. W. BROMLEY.
MACHINE FOR KNEADING DOUGH.

No. 551,714.

Patented Dec. 17, 1895.

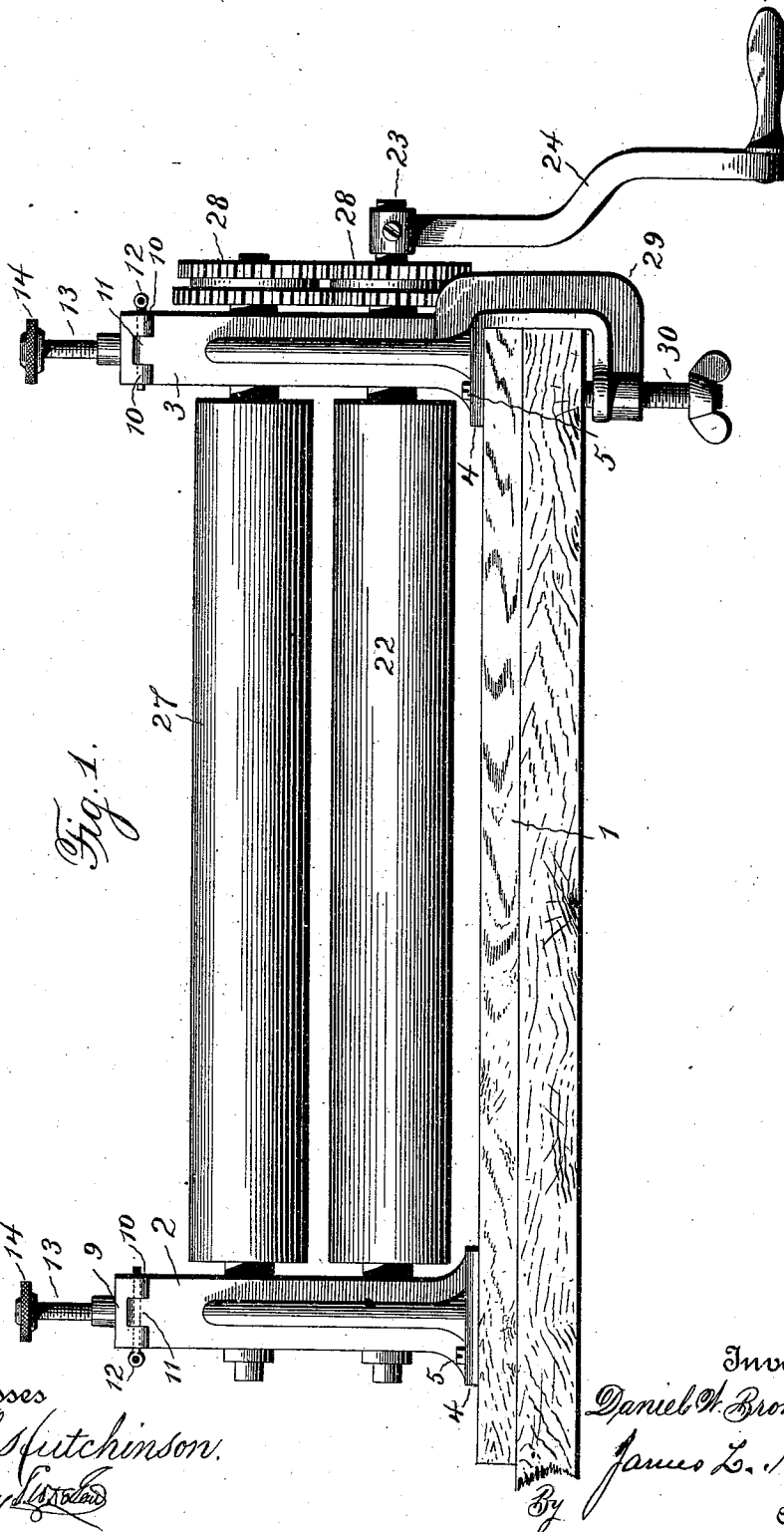

Fig. 1.

Witnesses
James Hutchinson.
Alroy L. ...

Inventor
Daniel W. Bromley,
James L. Norris,
By
Attorney

(No Model.)

2 Sheets—Sheet 2.

D. W. BROMLEY.
MACHINE FOR KNEADING DOUGH.

No. 551,714.

Patented Dec. 17, 1895.

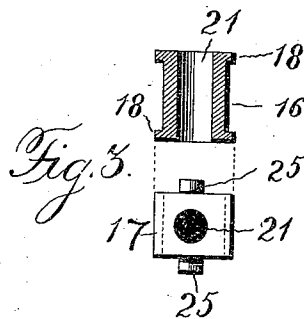
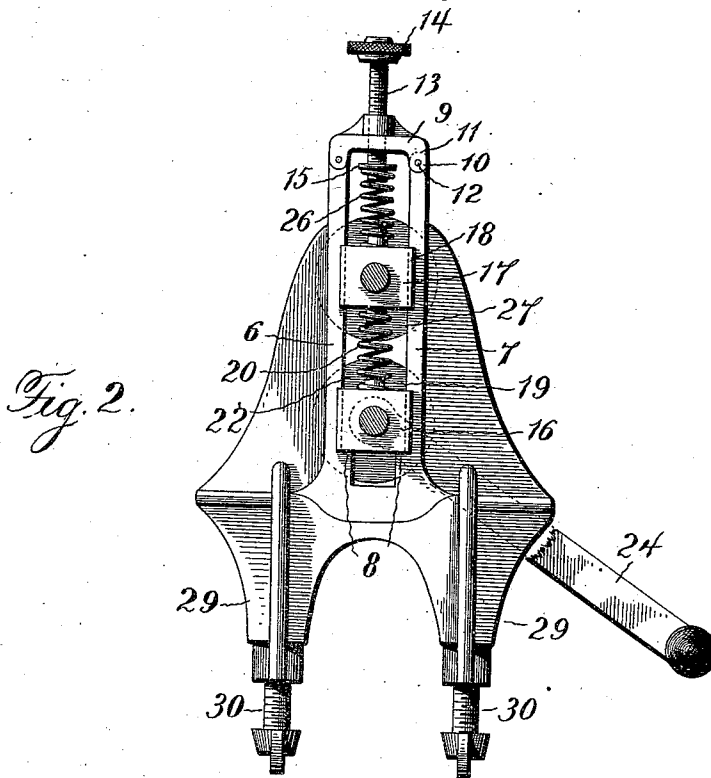

Witnesses
James Hutchinson
Alfred S. [unclear]

Inventor
Daniel W. Bromley
By *James L. Norris*
Attorney

UNITED STATES PATENT OFFICE.

DANIEL W. BROMLEY, OF LEXINGTON, KENTUCKY.

MACHINE FOR KNEADING DOUGH.

SPECIFICATION forming part of Letters Patent No. 551,714, dated December 17, 1895.

Application filed July 27, 1895. Serial No. 557,358. (No model.)

To all whom it may concern:

Be it known that I, DANIEL W. BROMLEY, a citizen of the United States, residing at Lexington, in the county of Fayette and State of Kentucky, have invented new and useful Improvements in Machines for Kneading Dough, of which the following is a specification.

This invention relates to dough-kneading machines, and has for its object to provide such a machine more especially designed for domestic use and which shall be simple, durable and inexpensive in construction and efficient in operation, and which may be readily taken apart for cleaning and similar purposes.

To these ends my invention consists in the novel features and in the construction, arrangement, or combination of parts herein-after described and pointed out in the claim following the description, due reference being had to the accompanying drawings, forming a part of this specification, in which—

Figure 1 is a front elevation of my improved dough-kneading machine. Fig. 2 is an end elevation thereof, and Fig. 3 is a detail view of one of the journal-boxes.

In order that those skilled in the art may make and use the invention, I will describe the same in detail, referring to said drawings, wherein—

The numeral 1 indicates the base upon which the machine is mounted and which may conveniently consist of a wooden board of any suitable or desired size and shape. Adapted to be secured to the opposite ends of the base 1 are two bifurcated standards 2 and 3, each having perforated bottom flanges 4, which are secured to said base by suitable screws 5. Said standards each consist of two parallel uprights 6 and 7, the adjacent faces of which are preferably planed smooth and are provided at their lower ends with inwardly-projecting lugs 8, which form supports for the lower journal-boxes presently to be described. To one of said uprights, as 6, of each of said standards is hinged one end of a yoke 9, the other end of which is provided with two downwardly-projecting parallel and perforated lugs 10, which are adapted to engage the opposite sides of and register with a perforated lug 11 formed on the upper end

of the opposite upright 7, a pin 12 being adapted to be passed through said perforated lugs to fasten the yokes to the uprights 7. A threaded aperture is formed in each of the yokes 9, in which is fitted an adjusting-screw 13, the upper end of which is provided with a hand-wheel 14, while upon the lower end thereof is rigidly secured an annular shoulder 15, for the purpose presently made apparent.

Seated between each of the uprights 6 and 7 are two journal-boxes 16 and 17, the lowermost boxes 16 each consisting of a cast metallic block provided at each side or edge with laterally-projecting flanges 18 that engage the opposite sides of the uprights 6 and 7 and prevent any lateral movement of said box between the uprights, and upon the upper side of each of said boxes is formed a projecting boss 19, over which is adapted to be seated a coiled spring 20. The boxes 16 rest upon and are supported by the shoulders 8 formed on the lower adjacent faces of the uprights 6 and 7, and said boxes are provided with coincident journal-bearings 21, in which are journaled the ends of a roll 22, one end of which, as 23, projects through the bearing in the standard 3 and is provided with a detachable crank-handle 24, by means of which said roll may be rotated.

Resting upon the coiled springs 20 are two journal-boxes 17, similar in all respects to the journal-boxes 16 before described, excepting that the boxes 17 are provided upon both their upper and lower sides with bosses 25, the lowermost of which seat within the upper ends of the coiled springs 20, while over the uppermost of said bosses are seated similar coiled springs 26, and in the upper ends of said last-mentioned springs project the lower ends of the adjusting-screws 13, the shoulders 15 on the latter resting upon the upper ends of said springs. A roll 27 is journaled in bearings in the boxes 17, said roll being similar in all respects to the roll 22, before described, and said rolls at one end are provided with intermeshing purchase-gear wheels 28, by means of which the motion of the driven roll 22 is communicated to the roll 27, causing the two to rotate in unison.

From the base of the standard 3 depend two brackets 29, in which are fitted thumb-

screws 30, by means of which the machine may be detachably secured to a table or other suitable support.

The operation of my improved machine will be readily understood from the foregoing description.

The device having been secured to a table or the like in the manner described, the dough is introduced between the rolls, and the latter rotated by turning the crank 24. The dough is thus drawn between said rolls and thereby rolled out and compressed, and by turning the adjusting-screws 13 in the proper direction the rolls may be adjusted toward or from one another to roll the dough out into any thickness desired. The coiled springs 20 operate to maintain the rolls the desired distance apart, while the springs 26 serve to cause said rolls to approach each other with a yielding pressure through the medium of the adjusting-screws 13, whereby said upper roll may yield vertically in both directions to perfectly accommodate itself to the dough being operated upon. By removing the pins 12 and throwing back the yokes 9 the rolls, together with their journal-boxes, may be instantly removed from the machine and thoroughly cleaned, and may, with equal facility and despatch, be restored to their normal positions.

The machine constructed as above described is exceedingly simple, durable and efficient, the parts may be readily taken apart for cleaning, and the rolls may be readily adjusted to suit the character of the material to be operated upon.

Having described my invention, what I claim is—

A dough kneading machine, consisting of a base, two parallel uprights 6 and 7 secured to each end thereof, said uprights being pro-

vided at their upper ends with perforated lugs and provided upon their adjacent faces near their lower ends with inwardly projecting lugs 8 to form supports for journal-boxes 16, yokes 9 hinged to one of said perforated lugs of each pair of parallel uprights and provided at their opposite ends with two parallel perforated lugs 10 that straddle the perforated lugs on the adjacent uprights and are detachably connected thereto by pins 12, vertically movable journal-boxes 16 and 17 arranged one above the other between said uprights, the said boxes each consisting of a block provided upon its opposite sides with laterally projecting flanges 18 that engage the opposite sides of said uprights, the boxes 16 each having a boss 19 on its upper side, and the boxes 17 each having bosses 25 on their upper and lower sides, rolls journaled in said boxes and provided at one end with intermeshing purchase gears, set screws 13 arranged in threaded apertures formed in the yokes 9 and provided near their lower ends with shoulders 15, coiled springs 20 arranged between the journal boxes 16 and 17 and disposed over the bosses thereon, and coiled springs 26 arranged between the journal boxes 17 and seated at their lower ends over the bosses on the upper sides of the journal boxes 17 and at their upper ends against the shoulders 15 on the set screws, substantially as shown and described.

In testimony whereof I have hereunto set my hand in presence of the subscribing witnesses.

DANIEL W. BROMLEY.

Witnesses:

J. B. GORHAM,
GEO. T. GESS,
FAUST FONSHU.