



US00D867481S

(12) **United States Design Patent**
Ikoma et al.

(10) **Patent No.:** **US D867,481 S**
(45) **Date of Patent:** **** Nov. 19, 2019**

(54) **ROBOT TOY**

(56) **References Cited**

(71) Applicant: **TOMY COMPANY, LTD.**, Tokyo (JP)

U.S. PATENT DOCUMENTS

(72) Inventors: **Akiko Ikoma**, Tokyo (JP); **Shu Katayama**, Tokyo (JP); **Mitsutoshi Tokuyama**, Tokyo (JP); **Shigeru Kanauchi**, Tokyo (JP); **Tomoyuki Tanaka**, Tokyo (JP)

D286,901 S *	11/1986	Ohno	D21/615
D294,611 S *	3/1988	Shinohara	D21/584
D301,353 S *	5/1989	Matsuda	D21/615
D478,362 S *	8/2003	Nakase	D21/615
D479,862 S *	9/2003	Takahashi	D21/615
D481,081 S *	10/2003	Okutsu	D21/615
D484,196 S *	12/2003	Nakase	D21/615
D510,963 S *	10/2005	Nakase	D21/578
D554,713 S *	11/2007	Wong	D21/615
D663,792 S *	7/2012	Wong	D21/615
D704,279 S *	5/2014	Murayama	D21/578

(73) Assignee: **TOMY COMPANY, LTD.**, Tokyo (JP)

(**) Term: **15 Years**

* cited by examiner

(21) Appl. No.: **29/658,461**

Primary Examiner — Sandra L Morris

(22) Filed: **Jul. 31, 2018**

(74) *Attorney, Agent, or Firm* — Oliff PLC

(30) **Foreign Application Priority Data**

(57) **CLAIM**

Feb. 9, 2018 (JP) 2018-002710

The ornamental design for a robot toy, as shown and described.

(51) **LOC (12) Cl.** **21-01**

DESCRIPTION

(52) **U.S. Cl.**

USPC **D21/615**; D21/578

(58) **Field of Classification Search**

USPC D6/598; D11/158, 162; D21/576–596, D21/604–605, 611–613, 615, 617–618, D21/621; 446/99, 268, 368–369, 376, 446/428, 487; 180/8.6; D30/160
CPC ... A63H 3/00; A63H 3/02; A63H 3/04; A63H 3/16; A63H 3/28; A63H 3/36; A63H 7/06; A63H 11/00; A63H 11/10; A63H 11/20; A63H 11/205; A63H 13/00; A63H 33/04; A63H 33/08; A63H 33/042; A63H 23/10

FIG. 1 is a right-side elevational view of the robot toy; FIG. 2 is a left-side elevational view thereof; FIG. 3 is a front elevational view thereof; FIG. 4 is a rear elevational view thereof; FIG. 5 is a top plan view thereof; FIG. 6 is a bottom plan view thereof; FIG. 7 is a front, right-side, top perspective view thereof; FIG. 8 is a rear, left-side, bottom perspective view thereof; FIG. 9 is a front, right-side, top perspective view of an alternate configuration thereof; and, FIG. 10 is a rear, left-side, bottom perspective view of the alternate configuration.

See application file for complete search history.

1 Claim, 10 Drawing Sheets

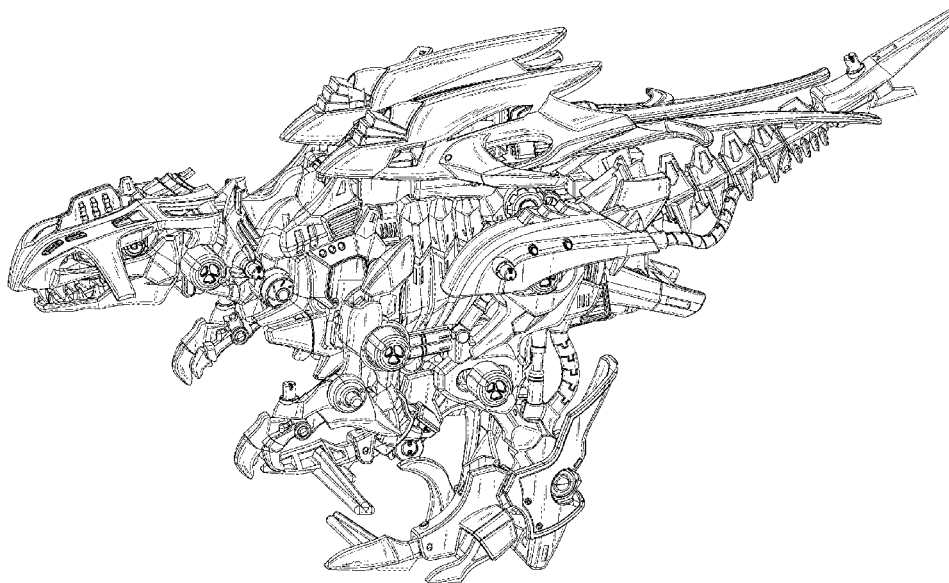

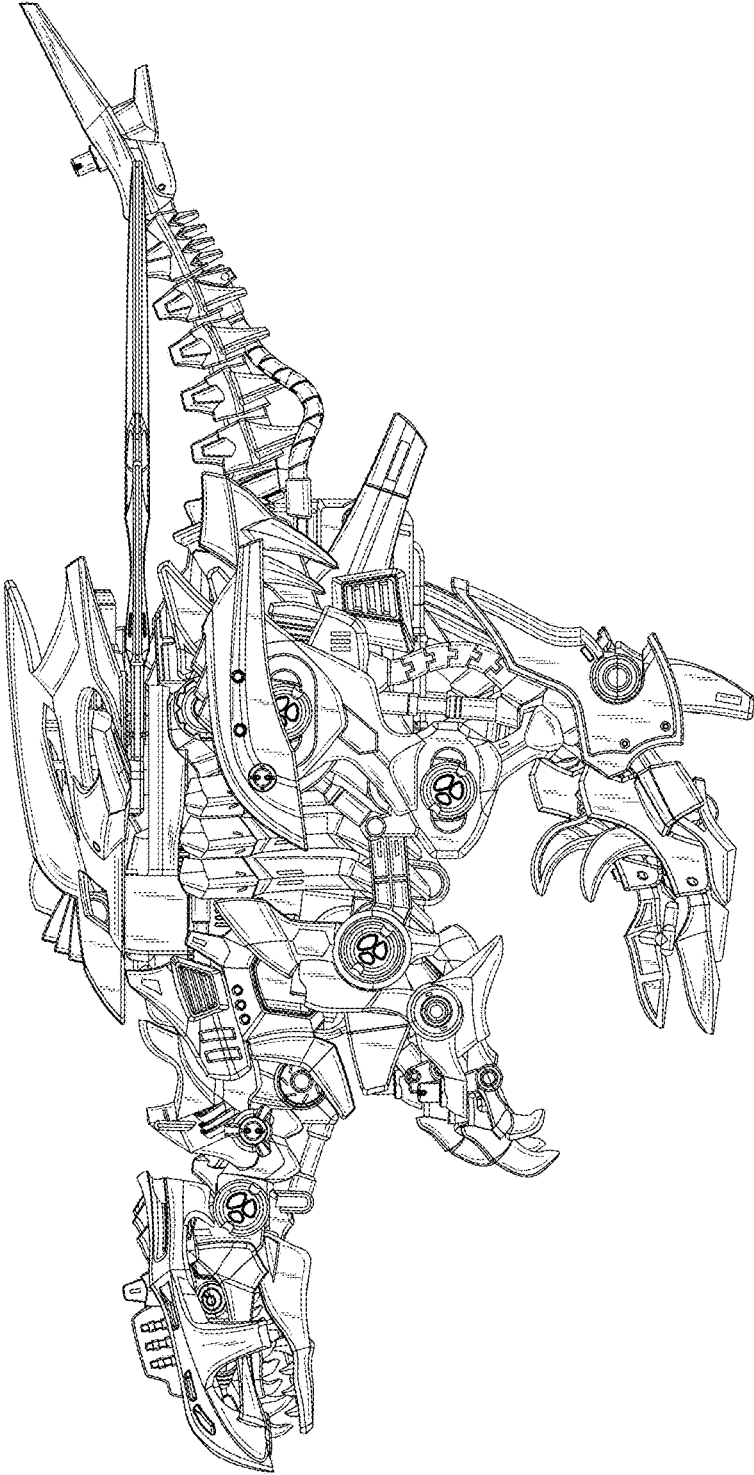

FIG. 1

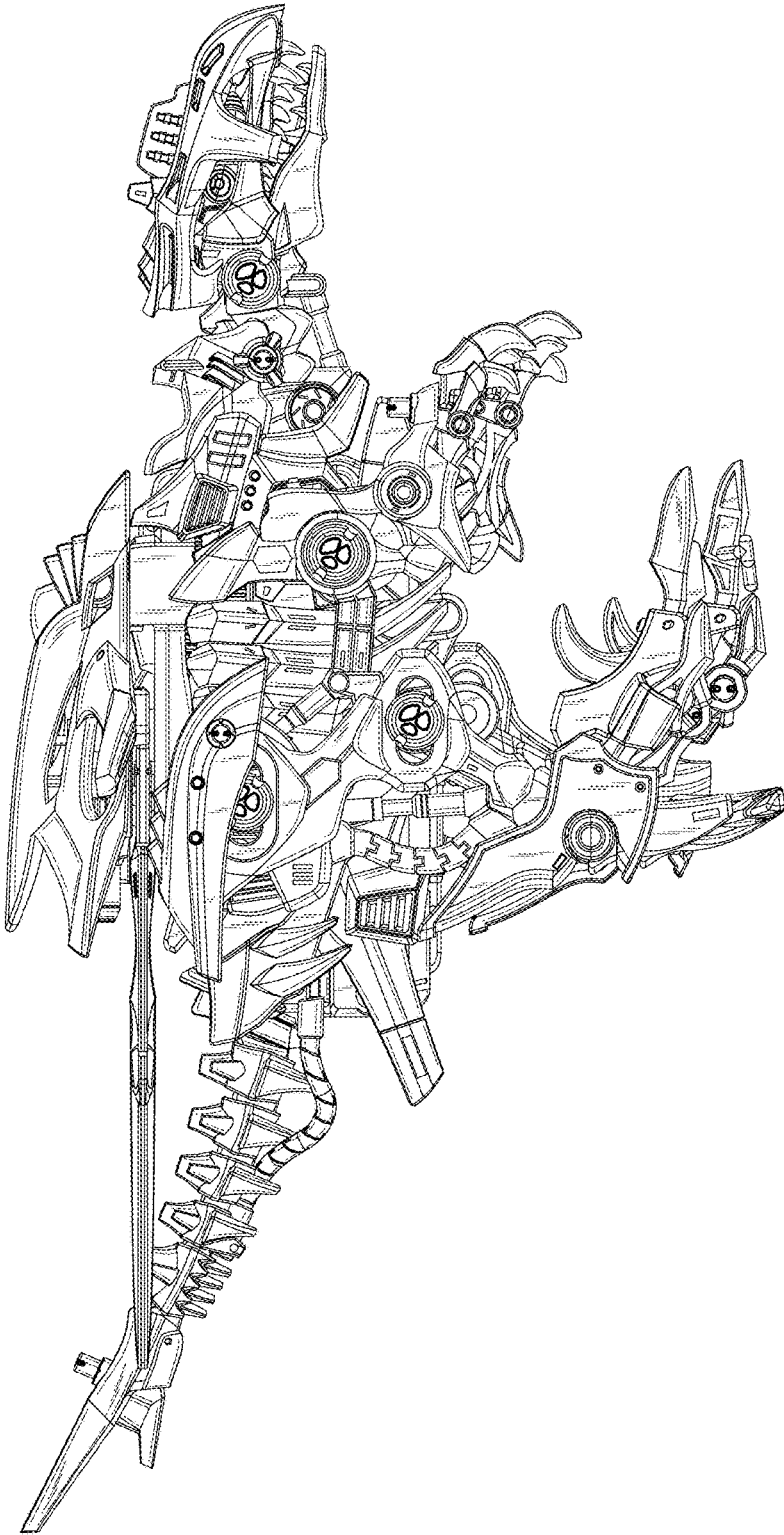

FIG. 2

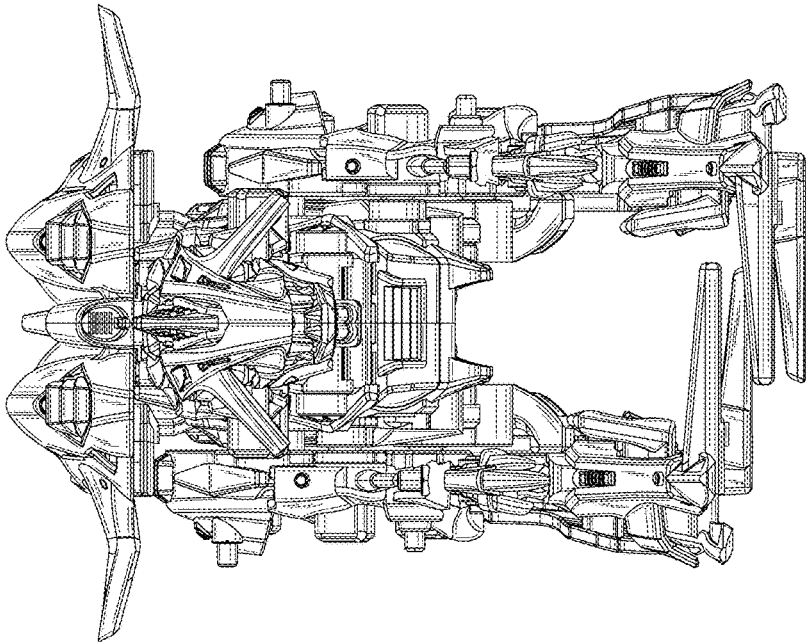

FIG. 3

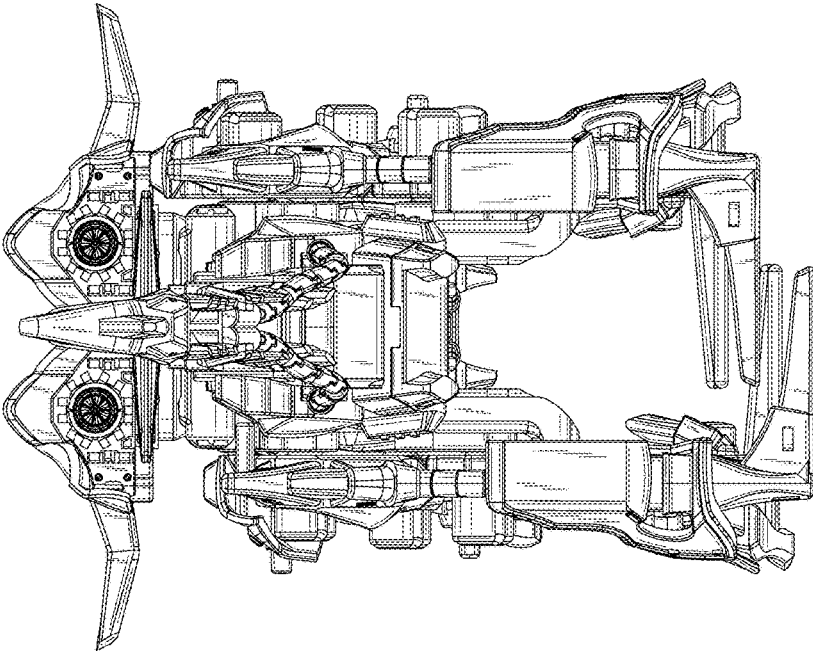

FIG. 4

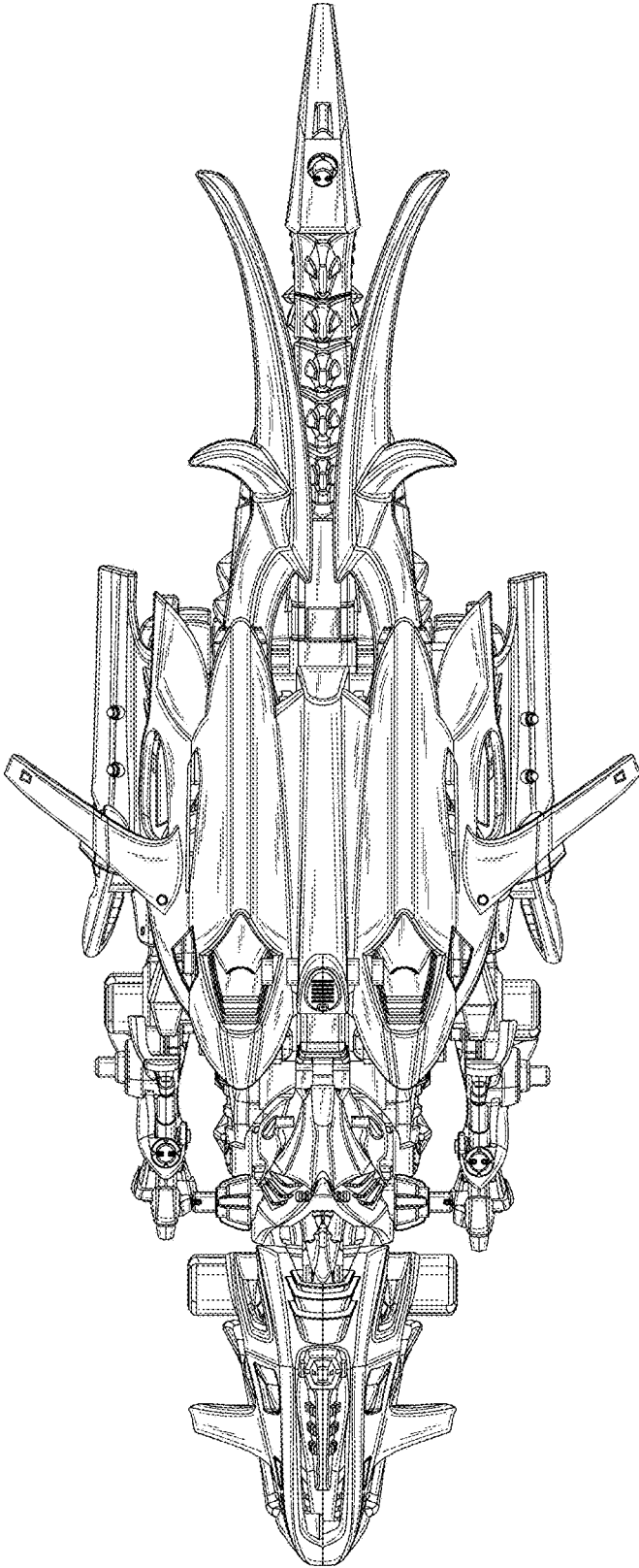

FIG. 5

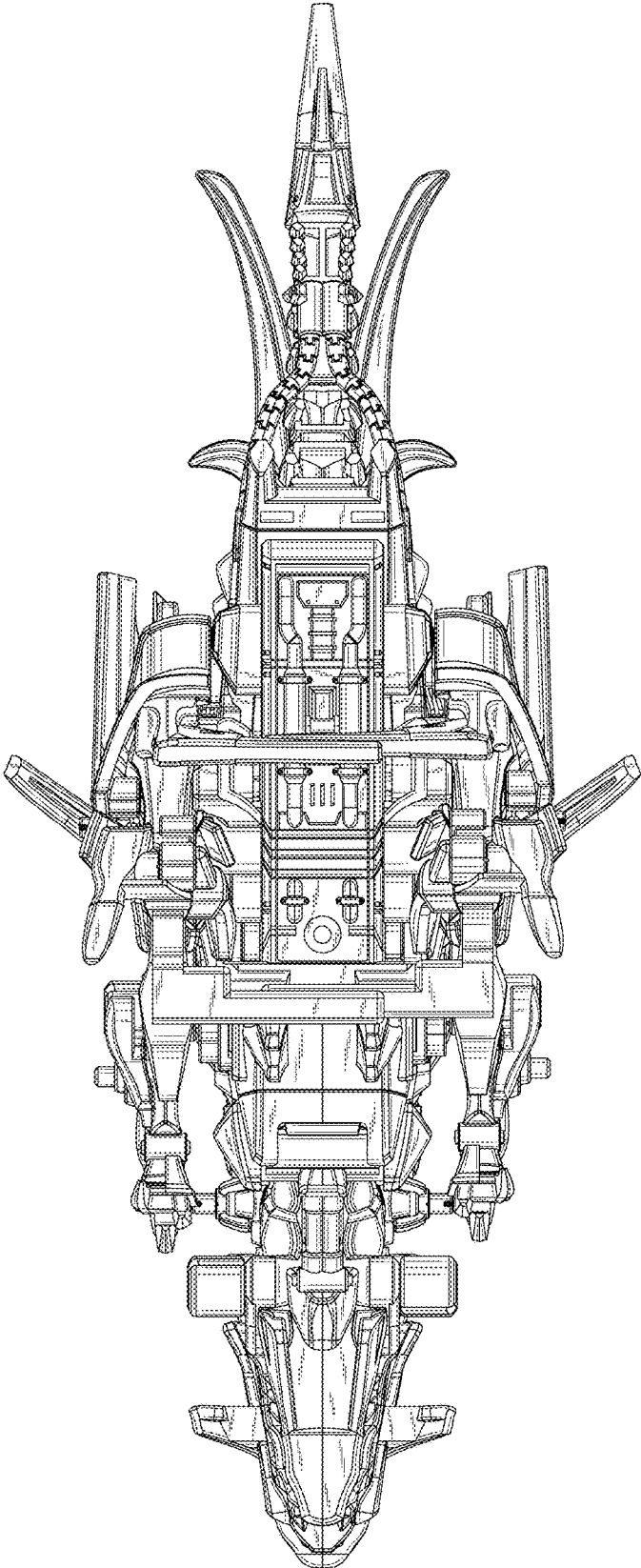

FIG. 6

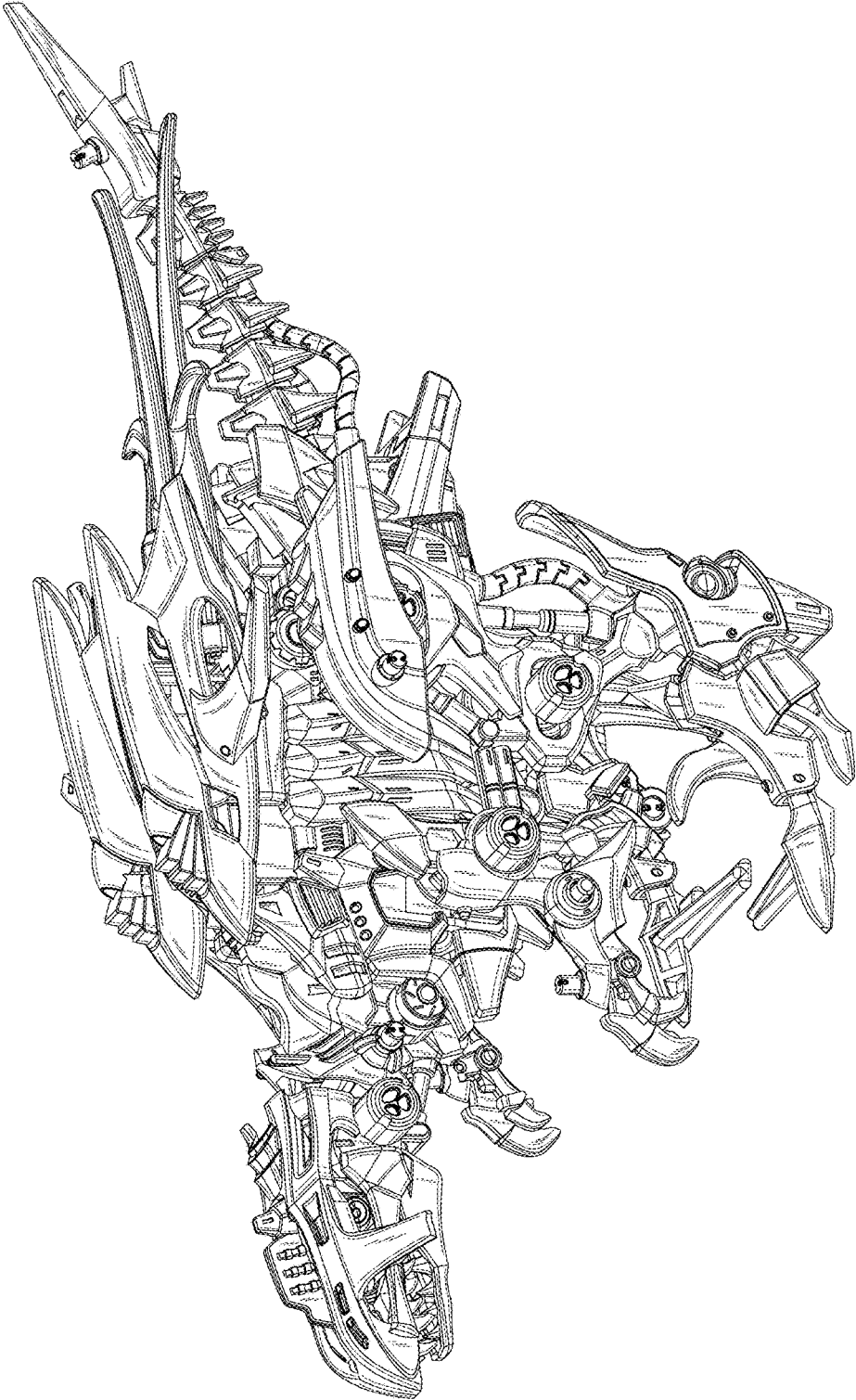

FIG. 7

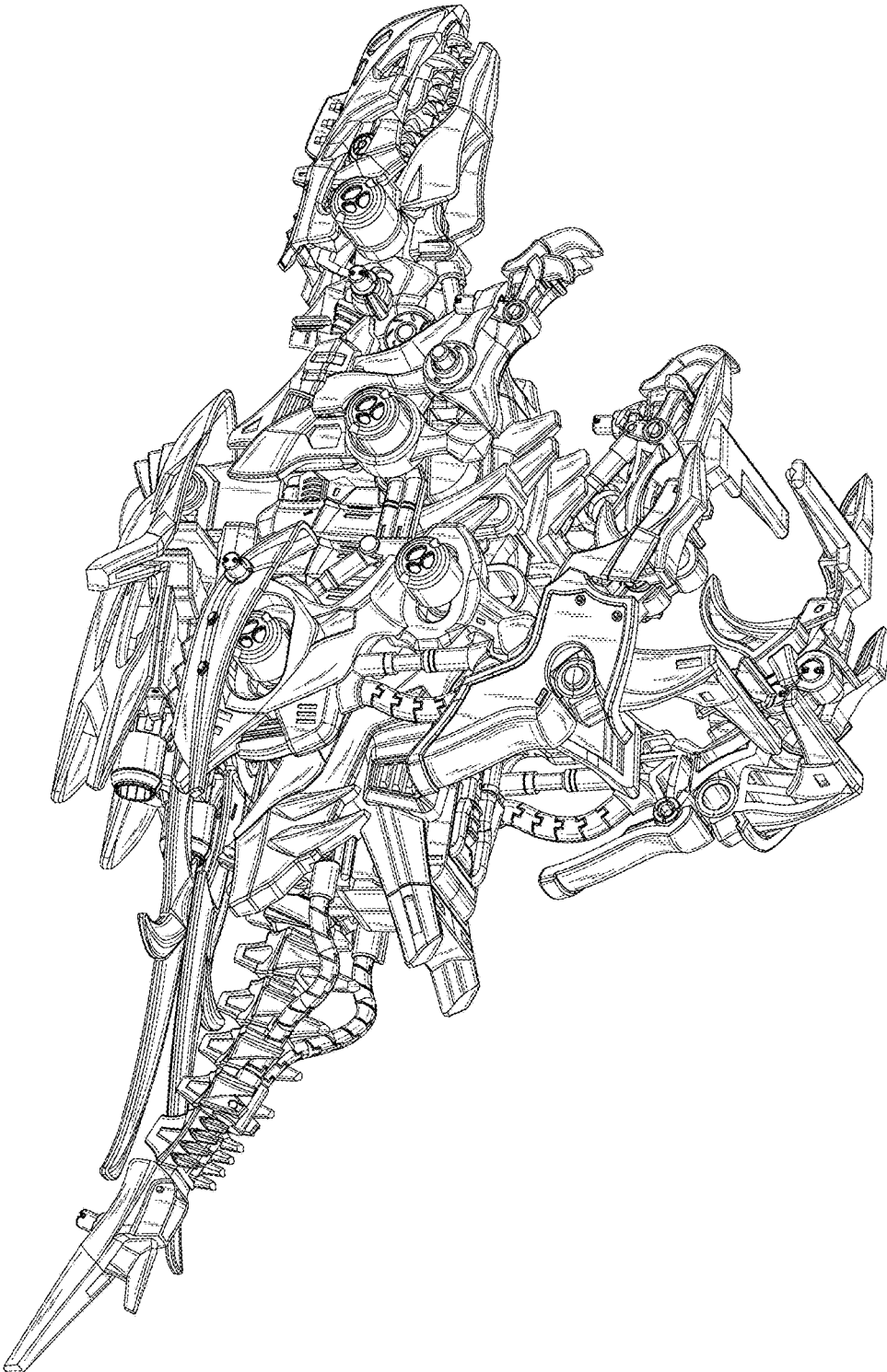

FIG. 8

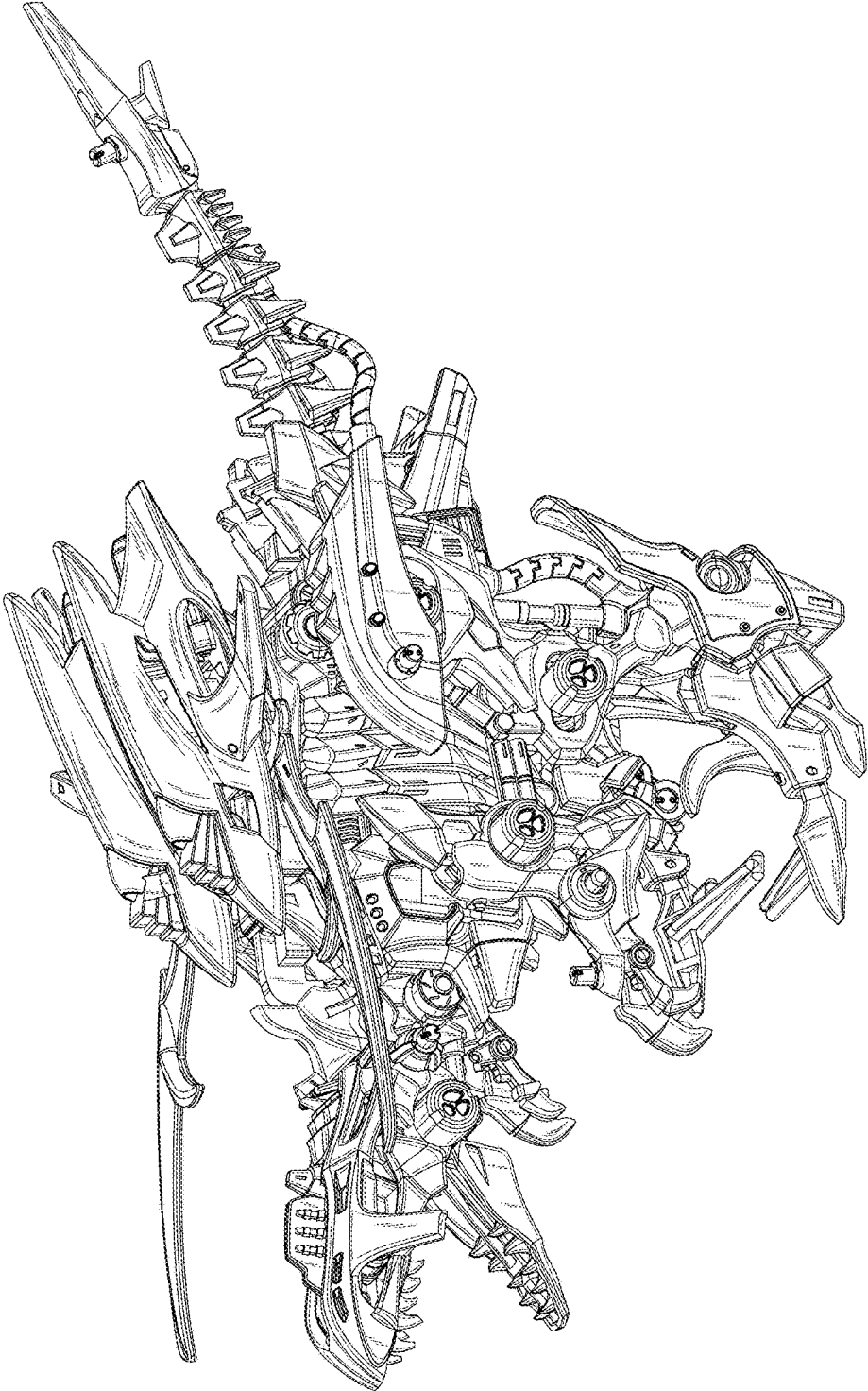

FIG. 9

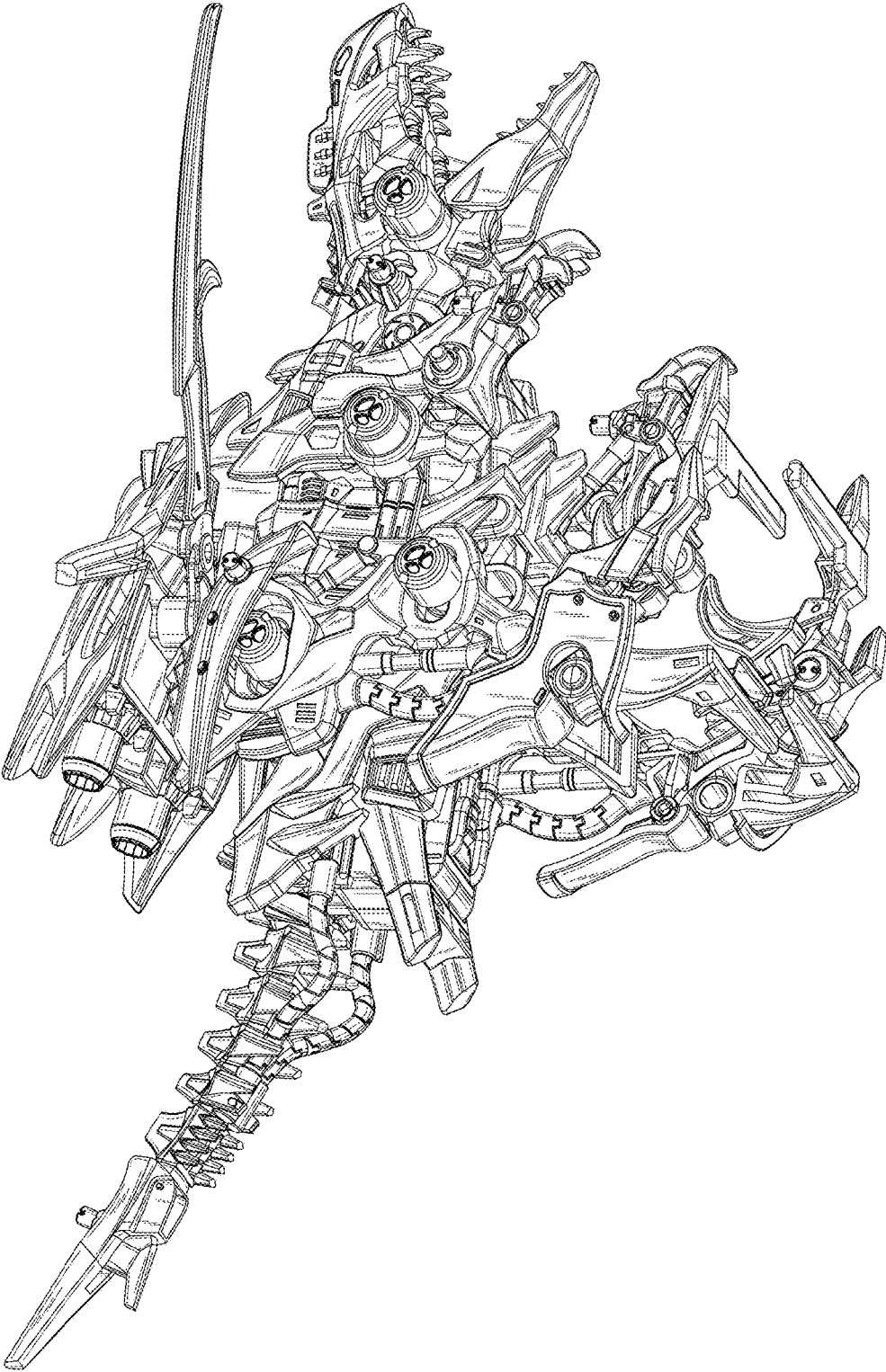

FIG. 10