



INTERNATIONAL APPLICATION PUBLISHED UNDER THE PATENT COOPERATION TREATY (PCT)

<p>(51) International Patent Classification ⁷ : H04B 7/185, 7/204</p>	<p>A1</p>	<p>(11) International Publication Number: WO 00/67397 (43) International Publication Date: 9 November 2000 (09.11.00)</p>
<p>(21) International Application Number: PCT/US00/12276 (22) International Filing Date: 3 May 2000 (03.05.00) (30) Priority Data: 09/305,180 4 May 1999 (04.05.99) US (71) Applicant: QUALCOMM INCORPORATED [US/US]; 5775 Morehouse Drive, San Diego, CA 92121-1714 (US). (72) Inventor: SCHIFF, Leonard, N.; 13689 Winstanley Way, San Diego, CA 92130 (US). (74) Agents: WADSWORTH, Philip, R. et al.; Qualcomm Incorporated, 5775 Morehouse Drive, San Diego, CA 92121-1714 (US).</p>	<p>(81) Designated States: AE, AG, AL, AM, AT, AU, AZ, BA, BB, BG, BR, BY, CA, CH, CN, CR, CU, CZ, DE, DK, DM, DZ, EE, ES, FI, GB, GD, GE, GH, GM, HR, HU, ID, IL, IN, IS, JP, KE, KG, KP, KR, KZ, LC, LK, LR, LS, LT, LU, LV, MA, MD, MG, MK, MN, MW, MX, NO, NZ, PL, PT, RO, RU, SD, SE, SG, SI, SK, SL, TJ, TM, TR, TT, TZ, UA, UG, UZ, VN, YU, ZA, ZW, ARIPO patent (GH, GM, KE, LS, MW, SD, SL, SZ, TZ, UG, ZW), Eurasian patent (AM, AZ, BY, KG, KZ, MD, RU, TJ, TM), European patent (AT, BE, CH, CY, DE, DK, ES, FI, FR, GB, GR, IE, IT, LU, MC, NL, PT, SE), OAPI patent (BF, BJ, CF, CG, CI, CM, GA, GN, GW, ML, MR, NE, SN, TD, TG).</p> <p>Published <i>With international search report. Before the expiration of the time limit for amending the claims and to be republished in the event of the receipt of amendments.</i></p>	

(54) Title: METHOD AND APPARATUS FOR MINIMIZING THE NUMBER OF CHANNELS USED FOR PAGING

(57) Abstract

A method and apparatus for paging a user terminal (UT) (124, 126) in a satellite communications system (100) having a at least one gateway (120, 122) and one or more satellites (116, 118), wherein each satellite produces a plurality of beams (401-416, 501-516) and each beam includes a plurality of channels, and wherein the one or more satellites (116, 118) produce a total number of beams m . The method of the present invention includes the step of recalling a location of the UT that corresponds to a known location of the UT at a time t_1 (704). The method also includes the step of determining a group (g_1) of beams that covers the recalled location of the UT at a time t_2 (706), where $g_1 < n$ and $t_2 > t_1$. A strongest beam of the group (g_1) of beams at time t_2 is then determined (708). In one embodiment, the strongest beam is selected by determining which beam of the group (g_1) of beams theoretically has a highest power relative to the recalled location at time t_2 (710). A page is then sent (712) from the gateway to the UT (124, 126) on a paging channel of the strongest beam. Accordingly, the present invention can be used to page a user terminal using a single channel of a single beam.

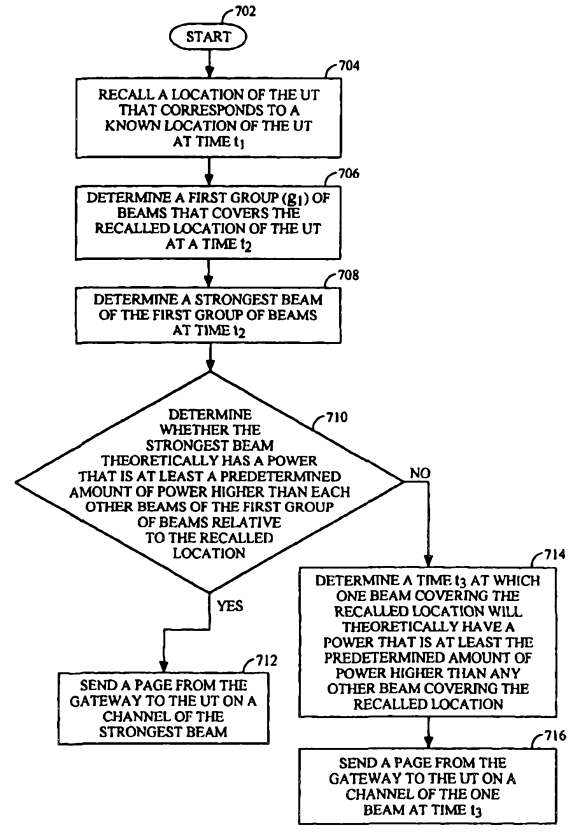

FOR THE PURPOSES OF INFORMATION ONLY

Codes used to identify States party to the PCT on the front pages of pamphlets publishing international applications under the PCT.

AL	Albania	ES	Spain	LS	Lesotho	SI	Slovenia
AM	Armenia	FI	Finland	LT	Lithuania	SK	Slovakia
AT	Austria	FR	France	LU	Luxembourg	SN	Senegal
AU	Australia	GA	Gabon	LV	Latvia	SZ	Swaziland
AZ	Azerbaijan	GB	United Kingdom	MC	Monaco	TD	Chad
BA	Bosnia and Herzegovina	GE	Georgia	MD	Republic of Moldova	TG	Togo
BB	Barbados	GH	Ghana	MG	Madagascar	TJ	Tajikistan
BE	Belgium	GN	Guinea	MK	The former Yugoslav Republic of Macedonia	TM	Turkmenistan
BF	Burkina Faso	GR	Greece	ML	Mali	TR	Turkey
BG	Bulgaria	HU	Hungary	MN	Mongolia	TT	Trinidad and Tobago
BJ	Benin	IE	Ireland	MR	Mauritania	UA	Ukraine
BR	Brazil	IL	Israel	MW	Malawi	UG	Uganda
BY	Belarus	IS	Iceland	MX	Mexico	US	United States of America
CA	Canada	IT	Italy	NE	Niger	UZ	Uzbekistan
CF	Central African Republic	JP	Japan	NL	Netherlands	VN	Viet Nam
CG	Congo	KE	Kenya	NO	Norway	YU	Yugoslavia
CH	Switzerland	KG	Kyrgyzstan	NZ	New Zealand	ZW	Zimbabwe
CI	Côte d'Ivoire	KP	Democratic People's Republic of Korea	PL	Poland		
CM	Cameroon	KR	Republic of Korea	PT	Portugal		
CN	China	KZ	Kazakstan	RO	Romania		
CU	Cuba	LC	Saint Lucia	RU	Russian Federation		
CZ	Czech Republic	LI	Liechtenstein	SD	Sudan		
DE	Germany	LK	Sri Lanka	SE	Sweden		
DK	Denmark	LR	Liberia	SG	Singapore		
EE	Estonia						

METHOD AND APPARATUS FOR MINIMIZING THE NUMBER OF CHANNELS USED FOR PAGING

5 BACKGROUND OF THE INVENTION

I. Field of the Invention

The present invention relates generally to satellite communication
10 systems, and more particularly, to a method and apparatus for paging a user
terminal using a single paging channel of a single beam.

II. Related Art

15 Conventional satellite-based communication systems include gateways
and one or more satellites to relay communication signals between the gateways
and one or more user terminals. A gateway is an earth station having an antenna
for transmitting signals to, and receiving signals from, communication satellites.
A gateway provides communication links, using satellites, for connecting a user
20 terminal to other user terminals or users of other communication systems, such
as a public switched telephone network. A satellite is an orbiting receiver,
repeater and regenerator used to relay information signals. A user terminal is a
wireless communication device such as, but not limited to, a wireless telephone,
a data transceiver, and a paging receiver. A user terminal can be fixed, portable,
25 or mobile, such as a mobile telephone.

A satellite can receive signals from and transmit signals to a user terminal
provided the user terminal is within the "footprint" of the satellite. The footprint
of a satellite is the geographic region on the surface of the Earth within the range
of signals of the satellite. The footprint is usually geographically divided into
30 "beams," through the use of beam-forming antennas. Each beam covers a
particular geographic region within the footprint. Beams may be directed so that

more than one beam from the same satellite covers the same specific geographic region.

Some satellite communications systems employ code division multiple access (CDMA) spread-spectrum signals, as disclosed in U.S. Patent No. 5 4,901,307, issued February 13, 1990, entitled "*Spread Spectrum Multiple Access Communication System Using Satellite or Terrestrial Repeaters,*" and U.S. Patent Application Serial No. 08/368,570, filed January 4, 1995, entitled "*Method and Apparatus for Using Full Spectrum Transmitted Power in a Spread Spectrum Communication System for Tracking Individual Recipient Phase Time and Energy,*" 10 both of which are assigned to the assignee of the present invention, and are incorporated herein by reference.

In satellite communication systems employing CDMA, separate communication links are used to transmit communication signals, such as data or traffic, to and from a gateway. The term "forward communication link" refers 15 to communication signals originating at the gateway and transmitted to a user terminal. The term "reverse communication link" refers to communication signals originating at a user terminal and transmitted to the gateway.

On the forward link, information is transmitted from a gateway to a user terminal over one or more beams. These beams often comprise a number of so-called subbeams (also referred to as frequency division multiple access (FDMA) 20 channels) covering a common geographic area, each occupying a different frequency band. More specifically, in a conventional spread-spectrum communication system, one or more preselected pseudorandom noise (PN) code sequences are used to modulate or "spread" user information signals over a predetermined spectral band prior to modulation onto a carrier signal for 25 transmission as communication signals. PN spreading is a method of spread-spectrum transmission that is well known in the art, and produces a communication signal with a bandwidth much greater than that of the data signal. On the forward link, PN spreading codes or binary sequences are used to 30 discriminate between signals transmitted by different gateways or over different

beams, as well as between multipath signals. These codes are often shared by all communication signals within a given subbeam.

In a conventional CDMA spread-spectrum communication system, "channelizing" codes are used to discriminate between different user terminals within a satellite sub-beam on a forward link (sometimes referred to as CDMA channels). That is, each user terminal has its own orthogonal channel provided on the forward link by using a unique channelizing orthogonal code. Walsh functions are generally used to implement the channelizing codes, also known as Walsh codes. The channelizing codes divide a subbeam into orthogonal channels, also known as Walsh channels. A majority of the Walsh channels are traffic channels that provide messaging between a user terminal and a gateway. The remaining Walsh channels often include pilot, sync, and paging channels. Signals sent over the traffic channels are meant to be received by only one user terminal. In contrast, paging, sync, and pilot channels may be monitored by multiple user terminals.

When a user terminal is not involved in a communications session (that is, the user terminal is not receiving or transmitting traffic signals), the gateway can convey information to that particular user terminal using a signal known as a paging signal (also referred to herein as a page). Paging signals are often sent by the gateway to establish a communication link, to tell a user terminal that a call is coming in, to reply to a user terminal trying to access the system, and for registration of the user terminal. For example, when a call has been placed to a particular user terminal, the gateway alerts the user terminal by means of a paging signal. Additionally, if the gateway is sending a short message to a user terminal, such as a request for a location update of the user terminal, the gateway can send such a request by means of a paging signal. Paging signals are also used to distribute channel assignments and system overhead information. Paging signals are usually transmitted over paging channels, which are briefly discussed above. Each paging signal includes an identity number so that the user terminals listening to the paging channel know if the paging signal is addressed to them. If a paging signal is meant for multiple user terminals, the

paging signal includes an identity number that corresponds to the multiple user terminals.

A user terminal can respond to a paging signal by sending an access signal or access probe over the reverse link (that is, the communications link originating at the user terminal and terminating at the gateway). The access signal is also used to register with a gateway, to originate a call, or to acknowledge a paging request by a gateway. The access signal is usually transmitted over channels specifically designated as access channels, which are briefly discussed above. The reverse link also includes traffic channels for providing messaging between a user terminal and a gateway.

If a user terminal is merely sending a location update in response to a location update request that is received from a gateway over a paging channel, the user terminal may send location update information as an access probe over an access channel. By using paging channels and access channels to convey short messages (such as location update requests and location update information), forward and reverse traffic channels are reserved for longer communications such as voice calls.

When a gateway sends a paging signal to a user terminal, the gateway usually does not know the location of the user terminal. Therefore, in contemporary satellite communications systems, the gateway usually sends a paging signal over many paging channels, one in each of several beams. At worst, the gateway sends the paging signal over every paging channel in every beam that is supported by the gateway serving the particular user terminal. It is generally not necessary to use a paging channel in every subbeam, as subbeam monitoring assignments within beams are usually known in advance, although this can be done as desired. This sending of a paging signal over many paging channels is often referred to as flood paging. Flood paging, though inefficient and wasteful, is relatively inexpensive when used to set up voice calls. This is because the resources used to flood page are relatively small compared to the resources used for a typical two or three minute voice call. More specifically, the total capacity and power used to flood page is relatively small compared to the

total power and capacity used to support the voice call. Thus, flood paging, though not efficient, has proven useful in voice systems. However, flood paging may become unacceptable when used for setting up voice calls, if, for example, the number of call set up requests increases to the point where paging channel capacity becomes a scarce resource.

The inefficiencies of flood paging are not acceptable in many other types of messaging systems, such as in a position determination system where the response to a paging message may be a relatively short acknowledgment message and/or a location update message. This is because the resources used to flood page are quite large as compared to the information sent in response to the flood page. More specifically, the total power and capacity used to flood page is relatively large compared to the total power and capacity used to support the response to the flood page (for example, an acknowledgment or location update message).

An example of an industry in which position determination is particularly useful is the commercial trucking industry. In the commercial trucking industry an efficient and accurate method of vehicle position determination is in demand. With ready access to vehicle location information, a trucking company home base obtains several advantages. For example, a trucking company can keep a customer informed of location, route and estimated time of arrival of payloads. The trucking company can also use vehicle location information together with empirical data on the effectiveness of routing, thereby determining the most economically efficient routing paths and procedures.

In order to minimize the power and capacity used to track the location of a truck, a location update request can be sent to a user terminal (often referred to as a Mobile Communications Terminal or MCT in the trucking industry) within the truck periodically (for example, once every hour). To further save resources, the collection of location updates should be accomplished without utilizing traffic channels. To accomplish this, a location update request message can be sent as a paging signal over a paging channel. To further minimize the power

and capacity used, the number of paging channels used to transmit the paging signal should be minimized for the reasons discussed above.

Thus, as discussed above, there is a need for a system or apparatus and method for reducing the number of paging channels used to page a user terminal. Even though the initial need for the reduction of flood paging was inspired by the reduction of flood paging in a position determination system, the system and method of the present invention is useful in any type of satellite communications system that uses channels (identical to or similar to paging channels) for conveying information to a user terminal that is not involved in a communications session. For example, the present invention is useful in a voice communications system that uses paging signals sent over paging channels to set up a voice call. This invention is especially useful in voice communications systems where the capacity of the paging channels is close to being exhausted due to an increasing number of call setup requests. Additionally, this invention is useful in a system where common paging channels are used for multiple applications, including but not limited to setting up voice communications and requesting location updates.

SUMMARY OF THE INVENTION

20

The present invention is directed toward a method and apparatus for paging a user terminal (UT) using a satellite communications system having a gateway and one or more satellites, wherein each satellite produces a plurality of beams and each beam includes a plurality of channels, and wherein the one or more satellites produce a total number of 'm' beams. The method of the present invention includes the step of recalling a location of the UT that corresponds to a known location of the UT at a time t_1 . This could be accomplished by using a look-up table, database, or memory elements in which location information for the user terminal at different times is stored. The method also includes the step of determining or selecting a group (g_1) of beams that covers the recalled location of the UT at a time t_2 , where $g_1 < n$ and $t_2 > t_1$. A strongest beam of the group (g_1)

30

of beams at time t_2 is then determined. In one embodiment, the strongest beam is selected by determining which beam, of the group (g_1) of beams theoretically has a highest power relative to the recalled location at time t_2 . A page is then sent from the gateway to the UT on a channel of the strongest beam. Accordingly, the present invention can be used to page a user terminal using a single channel of a single beam.

In one embodiment of the present invention the page is only sent at time t_2 if the strongest beam theoretically has a power that is at least a predetermined amount of power (for example, 3 or 4 dB) higher than each other beam of the group (g_1) of beams relative to the recalled location. Otherwise, a time t_3 is determined at which one beam covering the recalled location will theoretically have a power that is at least the predetermined amount of power higher than any other beam covering the recalled location. A page can then be sent over a channel of the one beam at time t_3 .

In one embodiment of the present invention, the strongest beam is determined with respect to an area within which the UT is assumed to be located at time t_2 .

In one embodiment of the present invention the UT monitors a channel of the actual strongest beam with respect to its current location. In another embodiment, the UT monitors a channel of a theoretically strongest beam with respect to its current location. In still another embodiment, the UT monitors a channel of a theoretically strongest beam with respect to a recalled location. In each of these embodiments, the UT can be paged by the gateway using a single channel of a single beam.

25

BRIEF DESCRIPTION OF THE DRAWINGS

The features, objects, and advantages of the present invention will become more apparent from the detailed description set forth below when taken in conjunction with the drawings in which like reference characters identify corresponding elements throughout and wherein:

30

FIG. 1A illustrates an exemplary wireless communication system in which the present invention is useful;

FIG. 1B illustrates exemplary communication links between a gateway and a user terminal;

5 FIG. 2 illustrates an exemplary transceiver for use in a user terminal;

FIG. 3 illustrates exemplary transceiver apparatus for use in a gateway;

FIG. 4 illustrates an exemplary satellite footprint;

FIGS. 5A and 5B illustrate exemplary satellite footprints at a time t_2 ;

FIGS. 6A and 6B illustrate exemplary satellite footprints at a time t_3 ;

10 FIGS. 7A and 7B are flowcharts depicting the high level operation of an embodiment of the present invention;

FIG. 8 is a flowchart depicting additional features of the operation of the present invention according to an embodiment of the present invention; and

15 FIGS. 9 and 10 are flowcharts depicting alternative methods performed by a user terminal in alternative embodiments of the present invention.

DETAILED DESCRIPTION OF THE PREFERRED EMBODIMENTS

20 I. Introduction

The present invention is particularly suited for use in communications systems employing low Earth orbit (LEO) satellites, wherein the satellites are not stationary with respect to a point on the surface of the Earth. However, the invention is also applicable to satellite systems in which the satellites travel in
25 non-LEO orbits, or systems using relatively high speed moving relay devices.

A preferred embodiment of the invention is discussed in detail below. While specific steps, configurations and arrangements are discussed, it should be understood that this is done for illustrative purposes only. A preferred
30 application is in CDMA wireless spread spectrum communication systems.

II. An Exemplary Satellite Communications System

An exemplary wireless communication system in which the present invention is useful is illustrated in FIG. 1A. It is contemplated that this communication system uses CDMA type communication signals, but this is not required by the present invention. In a portion of a communication system 100 illustrated in FIG. 1A, two satellites 116 and 118, and two associated gateways, base stations, or hubs 120 and 122 are shown for effecting communications with two remote user terminals 124 and 126. The total number of gateways and satellites in such systems depends on desired system capacity and other factors well understood in the art.

User terminals 124 and 126 each include a wireless communication device such as, but not limited to, a cellular or satellite telephone, a data transceiver, or a paging or position determination receiver, and can be hand-held or vehicle-mounted as desired. In FIG. 1A, user terminal 124 is illustrated as a vehicle mounted device and user terminal 126 is illustrated as a hand-held telephone. However, it is also understood that the teachings of the invention are applicable to fixed units where remote wireless service is desired. User terminals are sometimes also referred to as subscriber units, mobile stations, mobile units, or simply as "users" or "subscribers" in some communication systems, depending on preference.

Generally, beams from satellites 116 and 118 cover different geographical areas in predefined beam patterns. Beams at different frequencies, also referred to as FDMA channels or "sub-beams," can be directed to overlap the same region. It is also readily understood by those skilled in the art that beam coverage or service areas for multiple satellites might be designed to overlap completely or partially in a given region depending on the communication system design and the type of service being offered, and whether space diversity is being achieved.

A variety of multi-satellite communication systems have been proposed with an exemplary system employing on the order of 48 or more satellites,

traveling in eight different orbital planes in LEO orbits for servicing a large number of user terminals. However, those skilled in the art will readily understand how the teachings of the present invention are applicable to a variety of satellite system and gateway configurations, including other orbital distances and constellations.

In FIG. 1A, some possible signal paths are illustrated for communications between user terminals 124 and 126 and gateways 120 and 122, through satellites 116 and 118. The satellite-user terminal communication links between satellites 116 and 118 and user terminals 124 and 126 are illustrated by lines 140, 142 and 144. The gateway-satellite communication links, between gateways 120 and 122 and satellites 116 and 118, are illustrated by lines 146, 148, 150 and 152. Gateways 120 and 122 may be used as part of one or two-way communication systems or simply to transfer messages or data to user terminals 124 and 126.

FIG. 1B provides additional details of the communications between gateway 122 and user terminal 124 of communication system 100. Communication links between user terminal 124 and satellite 116 are generally termed user links and the links between gateway 122 and satellite 116 are generally termed feeder links. Communications proceeds in a "forward" direction from gateway 122 to satellite 116 on forward feeder link 160 and then down from satellite 116 to user terminal 124 on forward user link 162. In a "return" or "reverse" direction, communication proceeds up from user terminal 124 to satellite 116 on reverse user link 164 and then down from satellite 116 to gateway 122 on reverse feeder link 166.

In an example embodiment, information is transmitted by gateway 122 on forward links 160, 162 utilizing frequency division and polarization multiplexing. The frequency band used is divided up into a predetermined number of frequency "channels" or "beams." For example, the frequency band is divided into 8 individual 16.5 MHz "channels" or "beams" using right hand circular polarization (RHCP) and 8 individual 16.5 MHz "channels" or "beams" using left hand circular polarization (LHCP). These frequency "channels" or "beams" are further made up of a predetermined number of frequency division

5 multiplexed (FDM) "subchannels" or "subbeams." For example, the individual 16.5 MHz channels may in turn be made up of up to 13 FDM "subchannels" or "subbeams", each of 1.23 MHz bandwidth. Each FDM subbeam can include multiple orthogonal channels which are generally established using Walsh codes (also referred to as Walsh channels). A majority of the orthogonal channels are traffic channels that provide messaging between user terminals **124** and gateway **122**. The remaining orthogonal channels include pilot, sync and paging channels.

10 The pilot channel is transmitted by gateway **122** on forward link **160**, **162** and is used by user terminal **124** to obtain initial system synchronization, and time, frequency and phase tracking for acquiring transmitted signals in beams or acquire a subbeam (CDMA carrier).

15 The sync channel is transmitted by gateway **122** on forward link **160**, **162** and includes a repeating sequence of information which user terminal **124** can read after finding a pilot channel. This information is needed to synchronize user terminal **124** to the gateway **122** assigned to that subbeam. Paging channels are often used by gateway **122** on forward link **160**, **162** to establish a communication link, to tell user terminal **124** that a call is coming in, to reply to a user terminal trying to access the system, and for registration of the user terminal. Additionally, as will be explained in further detail below, paging channels can also be used for sending short messages, such as a position update request, to user terminal **124**.

25 The traffic channels are assigned on the forward and reverse links when a communication link is requested (for example, when a call is being placed). Messaging transfers between user terminal **124** and gateway **122** during a conventional communication link or phone call is accomplished using a traffic channel.

30 In the reverse direction, user terminal **124** transmits information to satellite **116** over user link **164**. Satellite **116** receives these signals from multiple user terminals (over link **164**) and frequency division multiplexes them together

for the satellite-to-gateway feeder link 166. Reverse link 164 contains traffic channels and access channels.

An access channel is used by user terminal 124 on reverse link 164, 166 to "access" gateway 122. Access channels, which are well known in the relevant art, provide communications from a user terminal to a gateway when the user terminal is not using a traffic channel. This could be to register on the system, to establish a communication link, to place a call, or to acknowledge a page sent by gateway 122. Additionally, as will be explained in further detail below, an access channel can also be used for sending a short message, such as a position update, from user terminal 124 to gateway 122. One or more access channels are generally paired with a paging channel to provide a more efficient means of user terminals selecting channels to use in response to pages. In some CDMA systems, each access channel on a reverse link is distinguished by a different PN code, which may be different in length or chipping rate than other PN codes used in spreading communication signals in the communication system, as desired. User terminal 124 responds to a page message by transmitting on one of the associated access channels. Similarly, gateway 122 responds to transmission on a particular access channel by a message on the access channel's associated paging channel.

20

III. User Terminal Transceiver

An exemplary transceiver 200 for use in user terminals 124 and 126 is illustrated in FIG. 2. Transceiver 200 uses at least one antenna 210 for receiving communication signals, which are transferred to an analog receiver 214, where they are down-converted, amplified, and digitized. A duplexer element 212 is often used to allow the same antenna to serve both transmit and receive functions. However, some systems employ separate antennas for operating at different transmit and receive frequencies.

The digital communication signals output by analog receiver 214 are transferred to at least one digital data receiver 216A and at least one searcher

30

receiver 218. Additional digital data receivers 216B-216N can be used to obtain desired levels of signal diversity, depending on the acceptable level of transceiver complexity, as would be apparent to one skilled in the relevant art.

At least one user terminal control processor 220 is coupled to digital data receivers 216A-216N and searcher receiver 218. Control processor 220 provides, among other functions, basic signal processing, timing, power and handoff control or coordination, and selection of frequency used for signal carriers. Another basic control function often performed by control processor 220 is the selection or manipulation of pseudonoise (PN) code sequences or orthogonal functions to be used for processing communication signal waveforms. Signal processing by control processor 220 can include a determination of relative signal strength and computation of various related signal parameters. Such computations of signal parameters, such as timing and frequency may include the use of additional or separate dedicated circuitry to provide increased efficiency or speed in measurements or improved allocation of control processing resources.

The outputs of digital data receivers 216A-216N are coupled to digital baseband circuitry 222 within the user terminal. User digital baseband circuitry 222 comprises processing and presentation elements used to transfer information to and from a user terminal. That is, signal or data storage elements, such as transient or long term digital memory; input and output devices such as display screens, speakers, keypad terminals, and handsets; A/D elements, vocoders and other voice and analog signal processing elements; and the like, all form parts of the user digital baseband circuitry 222 using elements well known in the art. If diversity signal processing is employed, user digital baseband circuitry 222 can comprise a diversity combiner and decoder. Some of these elements may also operate under the control of, or in communication with, control processor 220.

When voice or other data is prepared as an output message or communications signal originating with the user terminal, user digital baseband circuitry 222 is used to receive, store, process, and otherwise prepare the desired data for transmission. User digital baseband circuitry 222 provides this data to a

transmit modulator 226 operating under the control of control processor 220. The output of transmit modulator 226 is transferred to a power controller 228 which provides output power control to a transmit power amplifier 230 for final transmission of the output signal from antenna 210 to a gateway.

5 Transceiver 200 can also employ a precorrection element 232 in the transmission path to adjust the frequency of the outgoing signal. This can be accomplished using well known techniques of up- or down-conversion of the transmission waveform. In the alternative, a precorrection element 232 can form part of a frequency selection or control mechanism for the analog up-conversion
10 and modulation stage (230) of the user terminal so that an appropriately adjusted frequency is used to convert the digital signal to a desired transmission frequency in one step. Transceiver 200 can also employ a precorrection element 232 in the transmission path to adjust the timing of the outgoing signal. This can be accomplished using well known techniques of adding or subtracting delay in
15 the transmission waveform.

Digital receivers 216A-N and searcher receiver 218 are configured with signal correlation elements to demodulate and track specific signals. Searcher receiver 218 is used to search for pilot signals, or other relatively fixed pattern strong signals, while digital receivers 216A-N are used to demodulate other
20 signals associated with detected pilot signals. However, a data receiver 216 can be assigned to track the pilot signal after acquisition to accurately determine the ratio of signal chip energies to signal noise, and to formulate pilot signal strength. Therefore, the outputs of these units can be monitored to determine the energy in, or frequency of, the pilot signal or other signals. These receivers
25 also employ frequency tracking elements that can be monitored to provide current frequency and timing information to control processor 220 for signals being demodulated.

Control processor 220 uses such information to determine to what extent the received signals are offset from the oscillator frequency, when scaled to the
30 same frequency band, as appropriate. This and other information related to

frequency errors and Doppler shifts can be stored in a storage or memory element 236, as desired.

IV. Gateway Transceiver

5

An exemplary transceiver apparatus 300 for use in gateways 120 and 122 is illustrated in FIG. 3. The portion of gateway 120, 122 illustrated in FIG. 3 has one or more analog receivers 314 connected to an antenna 310 for receiving communication signals which are then down-converted, amplified, and digitized using various schemes well known in the art. Multiple antennas 310 are used in some communication systems. Digitized signals output by analog receiver 314 are provided as inputs to at least one digital receiver module, indicated by dashed lines generally at 324.

Each digital receiver module 324 corresponds to signal processing elements used to manage communications between a gateway 120, 122 and one user terminal 124, 126, although certain variations are known in the art. One analog receiver 314 can provide inputs for many digital receiver modules 324, and a number of such modules are often used in gateways 120, 122 to accommodate all of the satellite beams and possible diversity mode signals being handled at any given time. Each digital receiver module 324 has one or more digital data receivers 316 and a searcher receiver 318. Searcher receiver 318 generally searches for appropriate diversity modes of signals other than pilot signals. Where implemented in the communication system, multiple digital data receivers 316A-316N are used for diversity signal reception.

The outputs of digital data receivers 316 are provided to subsequent baseband processing elements 322 comprising apparatus well known in the art and not illustrated in further detail here. Exemplary baseband apparatus includes diversity combiners and decoders to combine multipath signals into one output for each user. Exemplary baseband apparatus also includes interface circuits for providing output data to a digital switch or network. A variety of other known elements such as, but not limited to, vocoders, data modems, and

30

digital data switching and storage components may form a part of baseband processing elements 322. These elements operate to control or direct the transfer of data signals to one or more transmit modules 334.

5 Signals to be transmitted to user terminals are each coupled to one or more appropriate transmit modules 334. A conventional gateway uses a number of such transmit modules 334 to provide service to many user terminals 124, 126 at a time, and for several satellites and beams at a time. The number of transmission modules 334 used by gateway 120, 122 is determined by factors well known in the art, including system complexity, number of satellites in view, 10 user capacity, degree of diversity chosen, and the like.

Each transmit module 334 includes a transmit modulator 326 which spread-spectrum modulates data for transmission. Transmit modulator 326 has an output coupled to a digital transmit power controller 328, which controls the transmission power used for the outgoing digital signal. Digital transmit power 15 controller 328 applies a minimum level of power for purposes of interference reduction and resource allocation, but applies appropriate levels of power when needed to compensate for attenuation in the transmission path and other path transfer characteristics. At least one PN generator 332 is used by transmit modulator 326 in spreading the signals. This code generation can also form a 20 functional part of one or more control processors or storage elements used in gateway 122, 124.

The output of transmit power controller 328 is transferred to a summer 336 where it is summed with the outputs from other transmit modules. Those outputs are signals for transmission to other user terminals 124, 126 at the same 25 frequency and within the same beam as the output of transmit power controller 328. The output of summer 336 is provided to an analog transmitter 338 for digital-to-analog conversion, conversion to the appropriate RF carrier frequency, further amplification and output to one or more antennas 340 for radiating to user terminals 124, 126. Antennas 310 and 340 may be the same antennas 30 depending on the complexity and configuration of the system.

At least one gateway control processor 320 is coupled to receiver modules 324, transmit modules 334, and baseband circuitry 322; these units may be physically separated from each other. Control processor 320 provides command and control signals to effect functions such as, but not limited to, signal processing, timing signal generation, power control, handoff control, diversity combining, and system interfacing. In addition, control processor 320 assigns PN spreading codes, orthogonal code sequences, and specific transmitters and receivers for use in user communications.

Control processor 320 also controls the generation and power of pilot, synchronization, and paging channel signals and their coupling to transmit power controller 328. The pilot channel is simply a signal that is not modulated by data, and may use a repetitive unchanging pattern or non-varying frame structure type (pattern) or tone-type input to transmit modulator 326. That is, the orthogonal function, Walsh code, used to form the channel for the pilot signal generally has a constant value, such as all 1's or 0's, or a well known repetitive pattern, such as a structured pattern of interspersed 1's and 0's. This effectively results in transmitting only the PN spreading codes applied from PN generator 332.

While control processor 320 can be coupled directly to the elements of a module, such as transmit module 324 or receive module 334, each module generally comprises a module-specific processor, such as transmit processor 330 or receive processor 321, which controls the elements of that module. Thus, in a preferred embodiment, control processor 320 is coupled to transmit processor 330 and receive processor 321, as shown in FIG. 3. In this manner, a single control processor 320 can control the operations of a large number of modules and resources more efficiently. Transmit processor 330 controls generation of, and signal power for, pilot, sync, paging signals, traffic channel signals, and any other channel signals and their respective coupling to power controller 328. Receiver processor 321 controls searching, PN spreading codes for demodulation and monitoring received power.

For certain operations, such as shared resource power control, gateways 120 and 122 receive information such as received signal strength, frequency measurements, or other received signal parameters from user terminals in communication signals. This information can be derived from the demodulated outputs of data receivers 316 by receive processors 321. Alternatively, this information can be detected as occurring at predefined locations in the signals being monitored by control processor 320, or receive processors 321, and transferred to control processor 320. Control processor 320 uses this information to control the timing and frequency of signals being transmitted and processed using transmit power controllers 328 and analog transmitter 338.

V. Satellite Beam Patterns

Generally, beams from satellites 116 and 118 cover different geographical areas in predefined beam patterns. Satellite beams are formed by, for example, a phased-array beam forming antenna, as would be apparent to one skilled in the relevant art. FIG. 4 illustrates an exemplary satellite beam pattern, also known as a footprint. As shown in FIG. 4, the exemplary satellite footprint 400 includes sixteen beams 401-416. More specifically, satellite footprint 400 includes an inner beam (beam 401), middle beams (beams 402-407), and outer beams (beams 408-416). Each beam 401-416 covers a specific geographical area, although there usually is some beam overlap. These specific geographic areas can be several hundred miles across. Additionally, beams at different frequencies, also referred to as FDM channels, CDM or CDMA channels, or "sub-beams," can be directed to overlap the same region. Beam coverage or service areas for multiple satellites might be designed to overlap completely or partially in a given region depending on the communication system design and the type of service being offered, and whether space diversity is being achieved.

In a preferred embodiment of the present invention, different beam patterns are employed for the forward and reverse communications links. Exemplary alternate forward and reverse link beam patterns are illustrated for

example in U. S. Patent Application Serial No.: 08/723,723, entitled "*Ambiguity Resolution For Ambiguous Position Solutions Using Satellite Beams*," filed September 30, 1996, now allowed, and incorporated herein by reference. However, the beam patterns of the forward and reverse communications links can be the same
5 without departing from the spirit and scope of the present invention.

VI. Preferred Embodiments of the Invention

A preferred embodiment of the present invention is discussed in detail
10 below. While specific steps, configurations and arrangements are discussed, it should be understood that this is done for illustrative purposes only. A person skilled in the relevant art will recognize that other steps, configurations and arrangements can be used without departing from the spirit and scope of the present invention. The present invention could find use in a variety of wireless
15 information and communication systems, including those intended for position determination.

As discussed above, there is a need for a system or apparatus and method for reducing the number of paging channels used to page user terminals, or similar apparatus. Paging channels are used for sending information to a user
20 terminal that is not in a communications session. For example, paging channels are often used by gateway 122 on forward link 160, 162 to establish a communication link, to tell user terminal 124 that a call is coming in, to reply to a user terminal trying to access the system, and for registration of user terminal 124. In a preferred embodiment, the paging channels are used to send a location
25 update request message from gateway 122 to user terminal 124.

The inventive method and system of reducing the number of paging channels used to page a user terminal is described herein with reference to FIGS. 5A, 5B, 6A and 6B. FIG. 5A illustrates the beam coverage areas of satellites 116 and 530 at a time t_2 . In a preferred embodiment, satellites 116 and 530 are
30 moving on a scheduled basis and illuminating different regions on the surface of the Earth at different points in time. More specifically, in a preferred

embodiment, satellites **116** and **530** are two satellites of a multiple satellite system wherein the satellites orbit such that they are not stationary with respect to a point on the surface of the Earth. The present invention is also useful in a geosynchronous satellite communications system where the satellites could indefinitely cover substantially the same geographic regions.

Assume that gateway **122** had communicated with user terminal **124** at a time t_1 and thereby knows the location of user terminal **124** at time t_1 . How gateway **122** had determined the location of user terminal **124** at time t_1 is discussed in further detail below. Now, assume that gateway **122** needs to page user terminal **124** at a time t_2 , where time t_2 is later in time than time t_1 . The purpose of the page may be for any of the uses discussed above including to inform user terminal **124** that a call is coming in or to request a location update from user terminal **124**. As discussed above, in a conventional satellite communications system, gateway **122** would flood page by sending a page over many, possibly all, of its paging channels because it does not know the location of user terminal **124** at time t_2 . That is, a page is transmitted on a given frequency, one channel, on all of the beams of all of the satellites (servicing the user terminal) based on knowing which FDMA channels a user terminal is listening on or to. The present invention avoids this flood paging by taking advantage of gateway **122** having knowledge of the location of user terminal **124** at a previous point in time, time t_1 . Before discussing further details of the present invention, below is a brief discussion of how gateway **122** could have determined the location of user terminal **124** at time t_1 .

Gateway **122** could have determined the location of user terminal **124** at time t_1 in a number of ways. For example, gateway **122** may have calculated the location of user terminal **124** at time t_1 based on information sent from user terminal **124** to gateway **122**. This information may have been sent from user terminal **124** to gateway **122** when, for example, user terminal **122** registered with gateway **122**, user terminal **122** attempted to initiate a call, and the like. Examples of systems and methods that can be used to determine a user terminal's location are disclosed in U.S. Patent No. 5,126,748, issued June 30,

1992, entitled "Dual Satellite Navigation System And Method," U.S. Patent Application No. 08/732,725, filed June 23, 1998, entitled "Unambiguous Position Determination Using Two Low-Earth Orbit Satellites," U.S. Patent Application No. 08/732,722, filed September 30, 1996, entitled "Passive Position Determination Using Two Low-Earth Orbit Satellites," and U.S. Patent Application No. 08/723,751, filed September 30, 1996, entitled "Position Determination Using One Low-Earth Orbit Satellite," each of which is assigned to the assignee of the present invention, and is incorporated herein by reference. These patents and applications discuss determining the location of a user terminal using information such as characteristics of communications signals transmitted to and from the user terminal and known positions and velocities of satellites. It is noted that the term "position" and "location" are used interchangeably herein.

Alternatively, user terminal 124 may have provided gateway 122 with its location at time t_1 . User terminal 124 may have used any available method for determining its location at time t_1 . In one embodiment, user terminal 124 includes a Global Positioning Satellite (GPS) receiver, which is well known in the art. Using the GPS receiver, user terminal 124 can determine and forward its location to gateway 122. User terminal 124 may also have determined its location using any other system or method such as a conventional LORAN-C system. User terminal 124 can forward location information to gateway 122 as an access probe on an access channel, embedded within other signals, or as a separate signal. In a preferred embodiment, user terminal 124 forwards the location information in the same access probe that acknowledges receipt of the page. The following features of the present invention apply regardless of how gateway 122 learns of the location of user terminal 124 at time t_1 .

Referring again to FIG. 5A, footprints 400 and 500 illustrate the beam coverage areas of satellites 116 and 530, respectively, at time t_2 . Footprint 400 includes sixteen beams 401-416, as discussed above, and footprint 500 includes sixteen beams 501-516. For the sake of clarity, portions of footprint 500 that overlap footprint 400 are shown as dotted lines. Location 520 (designated by an

"X") is the location of user terminal 124 at time t_1 . As discussed above, gateway 122 has knowledge of location t_1 .

As shown in FIG. 5A, at time t_2 location 520 is within the beam coverage area of both beam 406 (of satellite 116) and beam 511 (of satellite 530). By showing only beams 406, 511 and 503, FIG. 5B make this even more clear. If satellites 116 and 530 are geostationary satellites then the coverage of footprints 400 and 500 at time t_1 and t_2 would be substantially the same. However, if satellites 116 and 530 are non-geostationary satellites, as discussed above, then the coverage area of footprints 400 and 500 would be different at time t_1 than shown in FIGS. 5A and 5B. Further, depending on the time between time t_1 and time t_2 , the beam coverage areas of satellite 116 (footprint 400) and satellite 530 (footprint 500) may not have overlapped location 520 at time t_1 .

The present invention takes advantage of gateway 122 knowing the location of user terminal 124 at a previous point in time. More specifically, by knowing the location 520 of user terminal 124 at time t_1 , and by assuming that user terminal 124 could have only traveled a limited distance in the time period between time t_1 and time t_2 , gateway 122 can hypothesize which beams cover user terminal 124 at time t_2 . For example, if time t_1 was one hour prior to time t_2 , it can be assumed that user terminal 124 did not travel any further than 80 miles in any direction from its location at time t_1 . That is, gateway 122 can assume that user terminal 124 is within a certain area at time t_2 based on a recalled location of user terminal 124 at time t_1 . Using such an assumption, gateway 122 can hypothesize which beams cover user terminal 124 at time t_2 . The beam(s) hypothesized to cover user terminal 124 at time t_2 shall be referred to herein as a first group of beams, designated g_1 . As discussed above, the present invention is directed to a system and method of paging user terminal 124 over a single channel of a single beam. More specifically, once gateway 122 has determined the first group of beams, gateway 122 can then determine a strongest beam of the first group of beams. Gateway 122 can then send a page to user terminal 124 on a paging channel of the strongest beam.

From the perspective of user terminal 124, the actual strength of a received signal sent over a channel of a beam may vary depending on where user terminal 124 is located (within the area that gateway 122 assumes user terminal 124 is located). Additionally, various environmental factors can diminish the power of a signal during its transmission from gateway 122 to user terminal 124. Thus, the so called "strongest beam" determined by gateway 122 (or a facility in communications with gateway 122) is actually a theoretically strongest beam relative to a specific location or area (for example, a recalled location of user terminal 124). For example, the theoretically strongest beam relative to location 520 is the beam that gateway 122 determines to most likely provide the strongest signal to a user terminal located at location 520.

In one embodiment, gateway 122 sends a page over a paging channel of the "theoretically strongest" beam. If the beam includes multiple paging channels, then gateway 122 can determine which paging channel to use based on a unique identity number of user terminal 124, as is well known in the relevant art.

In one embodiment, user terminal 124 determines an "actual strongest" beam of the beams covering user terminal 124. User terminal 124 can do this, for example, by measuring the signal strength of signals received over channels of different beams. User terminal 124 then monitors a channel of the actual strongest beam. In one embodiment user terminal 124 monitors a paging channel of the actual strongest beam, as discussed below in the description of FIG. 7B. If the "theoretically strongest" beam determined by gateway 122 is the same as the "actual strongest" beam determined by user terminal 124, then user terminal 124 will receive a page that is sent by gateway 122 over a paging channel of the theoretically strongest beam at time t_1 . This is because user terminal 124 will be monitoring the channel of the beam that gateway 122 uses to send the page. However, if the theoretically strongest beam determined by gateway 122 is different than the actual strongest beam determined by user terminal 124, then user terminal 124 will not receive the page sent at time t_1 .

In order to increase the probability that a theoretically strongest beam and an actual strongest beam are the same beam, gateway 122 can wait, if necessary, to send the page until one beam theoretically has a power that is at least a predetermined amount of power higher than any other beam covering the area within which gateway 122 assumes user terminal 124 is located. More specific details of this feature of the present invention are described below with reference to the flow charts in FIGS. 7A and 8.

In another embodiment, gateway 122 and user terminal 124 each independently determine a theoretically strongest beam. User terminal 124 continually monitors a paging channel of the theoretically strongest beam, which can change over time. If user terminal 124 and gateway 122 use identical algorithms and identical variables (the values input into the algorithm), user terminal 124 should receive pages sent by gateway 122. However, if user terminal 124 and gateway 122 use identical algorithms, but different variables, there is the possibility that user terminal 124 and gateway 122 will determine or select different theoretically strongest beams. Where user terminal 124 and gateway 122 use identical algorithms but different variables, features of the present invention increase the probability that user terminal 124 and gateway 122 will determine the same theoretically strongest beam. More specific details of these embodiments of the present invention are described below with reference to the flow charts in FIGS. 9 and 10.

A. User Terminal Monitors A Channel of the Actual Strongest Beam

FIGS. 7A and 7B provide a high level description of one embodiment of the present invention. For exemplary purposes, the method of FIGS. 7A and 7B shall be described with reference to FIGS. 5A, 5B, 6A and 6B. FIGS. 5A and 5B respectively illustrate the footprints of satellites 116 and 530 at time t_2 . FIGS. 6A and 6B respectively illustrate the same footprints at a time t_3 , wherein t_3 is later in time than t_2 . The steps of FIG. 7A are performed by gateway 122 or a facility in

communications with gateway 122. The steps of FIG. 7B are performed by user terminal 124.

More specifically, the steps of FIG. 7B are performed by user terminal 124 in the embodiment of the present invention where user terminal 124 monitors a channel of an actual strongest beam. In step 724 user terminal 124 determines an actual strongest beam with respect to its current location. User terminal 124 can do this by measuring the signal strength of signals received over channels of various beams covering user terminal 124. In step 726, user terminal 124 monitors a channel of the actual strongest beam determined in step 724. User terminal 124 continually performs these steps such that it is generally monitoring a channel of the beam that is actually strongest with respect to its current location.

Referring to FIG. 7A, the first step performed by gateway 122 (or a facility in communications with gateway 122), step 704, is recalling the location of user terminal 124 at time t_1 . This can be accomplished by performing a lookup in a table, list, or database stored in one or more memory elements or circuits, that is used to store location information of user terminals at different points in time. The location of user terminal 124 at time t_1 shall be referred to herein as recalled location 520. Recalled location 520 could have been determined using any method including those discussed above.

In step 706, using knowledge of the satellite constellation, including the beam coverage areas of the satellites at different points in time, a determination is made of which beams cover recalled location 520 at time t_2 . The beams which cover recalled location 520 at time t_2 shall be referred to herein as the first group of beams, designated g_1 . As discussed above, if the satellite constellation is geosynchronous then the same beams that covered recalled location 520 at time t_1 would also cover recalled location 520 at time t_2 . If the satellite constellation is not geosynchronous, then different beams would probably cover recalled location 520 at time t_2 as compared to at time t_1 (unless the period between time t_2 and time t_1 is short, for example, a few seconds, or so long as to allow a complete orbit traversal by the satellite).

The first group of beams can consist of one beam or multiple beams. Additionally, the first group of beams may be produced by the same satellite or by multiple satellites. For example, the first group of beams may include two beams of the same satellite if recalled location 520 is located at the edge of two
5 beams produced by the same satellite. Furthermore, if footprints of different satellites overlap, as they do in FIGS. 5A and 5B, the first group of beams can include beams produced by different satellites. For the example of FIGS. 5A and 5B, the first group includes beam 406 (produced by satellite 116) and beam 511 (produced by satellite 530).

10 In step 708, once it is determined which beams cover recalled location 520 at time t_2 (that is, the first group of beams are determined), gateway 122 determines a strongest beam of the first group of beams.

In one embodiment, the determined strongest beam is the beam that theoretically has a highest power relative to recalled location 520 at time t_2 .
15 FIG. 5B illustrates the theoretical relative powers of beams 406 and 511. It can be seen that the signal power of a beam is strongest at the center of a beam and weakest at the edge of a beam. Typically, the signal power at the edge of each beam is approximately 3 dB less (half the power) than the power at the center of each beam. Referring to FIG. 5B, beam 406 is theoretically the strongest beam, of
20 the first group of beams, with respect to recalled location 520. More specifically, with respect to location 520, beam 406 theoretically has a power that is 2.5 dB higher than beam 511 (the difference between -2.0 dB and -4.5 dB).

A page can then be sent over a channel of the strongest beam determined in step 708. However, if this strongest beam is for example only 2 dB higher than
25 the next strongest beam, there is a relatively high probability that user terminal 124 (which is monitoring the beam that is actually strongest at its current location) is not monitoring a channel of the theoretically strongest beam determined in step 708. This is because another beam can have a higher power than the theoretically strongest beam, with respect to the actual location of user
30 terminal 124 at time t_2 . When looking at beams from multiple satellites, various environmental factors that can diminish the power of a signal during its

transmission from gateway 122 to user terminal 124 may cause the "theoretically strongest" beam from one satellite for a specific location to be different than the "actual strongest" beam being received (from other satellite) for that specific location. The present invention includes additional features to increase the probability that gateway 122 sends a page over the channel that user terminal 124 is monitoring. More specifically, in step 710 a determination is made whether or not the strongest beam determined in step 708 theoretically has a power that is at least a predetermined amount of power higher than a threshold, which is generally set as the power of each other beam of the first group of beams relative to recalled location 520. This step can be accomplished by determining the theoretical power, relative to recalled location 520, for each beam of the first group of beams.

Assume that this threshold predetermined amount of power is, for example, 3 dB. That is, if the strongest beam determined in step 708 is theoretically at least 3 dB stronger than the theoretical power of each other beam of the first group of beams, then the probability is high that user terminal 124 is listening to the theoretically strongest beam determined in step 708. Accordingly, if the answer to step 710 is YES, then in step 712 a page is sent from gateway 122 to user terminal 124 on the paging channel of the strongest beam determined in step 708.

As discussed above, the signal strength or power of the strongest beam 406 is theoretically only 2.5 dB stronger than beam 511, with respect to recalled location 520 at time t_2 . Thus, for this example the answer obtained in step 710 is NO.

If the answer in step 710 is NO, then a time t_3 is determined in step 714. Time t_3 is a future point in time (later in time than t_2) at which one beam covering recalled location 520 will theoretically have a power that is at least the predetermined amount of power higher (for this example, 3 dB) than any other beam covering recalled location 520. In one embodiment this one beam is selected from the first group of beams including the strongest beam determined in step 708. In another embodiment, this one beam is selected from any of the

total number of 'm' beams produced by all of the satellites of communications system 100. By waiting until one beam has a power that is theoretically the predetermined amount of power higher than each other beam covering the recalled location, the probability is increased that user terminal 124 is actually
5 monitoring a channel of that one beam when a page is sent.

Time t_3 can be determined at gateway 122 or at some other facility that is in communications with gateway 122, such as at one or more central command or control centers for communications system 100. Time t_3 can be determined using knowledge of the satellite constellation, including the beam coverage areas
10 of the satellites at different points in time. Time t_3 could be determined for example by setting it at $t_3 - t_2 = t_2 - t_1$. If paging fails at this point in time, one can proceed to a time t_4 determined similarly, and so forth.

The coverage areas of beams change over time if the satellites transmitting the beams are not stationary with respect to a point on the surface of the Earth.
15 As mentioned above, FIGS. 6A and 6B illustrate the coverage areas of beams transmitted from satellite 118 (footprint 400) and satellite 530 (footprint 500) at a future point in time, time t_3 . When comparing FIGS. 6A and 6B to FIGS. 5A and 5B it can be seen that footprints 400 and 500 will move with respect to one another and with respect to recalled location 520. FIGS. 6A and 6B show that
20 beams 406 and 511 will still be the only beams to cover recalled location 520 at time t_3 . However, it can be seen that recalled location 520 will be closer to the center of beam 406 and closer to the edge of beam 511 at time t_3 . Specifically, referring to FIG. 6B, beam 406 at time t_3 will have a strength that is theoretically 6 dB (the difference between 0 dB and -6 dB) higher than beam 511, with respect to
25 recalled location 520. Thus, at time t_3 beam 406 will theoretically have a power that is at least the predetermined amount of power higher (in this example, 3 dB) than any other beam covering recalled location 520. Thus, if gateway 122 waits until time t_3 to send a page over a channel of beam 406, the probability is increased that user terminal 124 will actually be monitoring the channel of beam
30 406.

Accordingly, in step 716, gateway 122 waits until time t_3 and sends a page to user terminal 124 on a paging channel of the one beam that is determined to theoretically have a power or signal strength that is at least the predetermined amount higher than any other beam covering recalled location 520. For the example of FIGS. 5A, 5B, 6A and 6B, gateway 122 sends a page over a channel of beam 406 at time t_3 .

It is noted that the steps of sending a page from gateway 122 to user terminal 124 (steps 712 and 716) do not include the step of user terminal 124 receiving the page. Furthermore, steps 712 and 716 do not imply that user terminal 124 is definitely located within a geographic region where it is capable of receiving the page (that is, the paging signal may be out of range of the user terminal). What occurs in steps 712 and 716 is gateway 122 sends a page over a channel of a beam that gateway 122 hypothesizes user terminal 124 is monitoring. Thus, gateway 122 does not know whether or not user terminal 124 received the page until user terminal 124 sends a message to gateway 122 acknowledging receipt of the page.

It is also noted that the threshold predetermined amount of power can be a value other than 3 dB without departing from the spirit and scope of the present invention.

Alternative and more detailed steps of the method of FIG. 7A are described with reference to FIG. 8. As alluded to above, the first group of beams can be determined with respect to an area surrounding recalled location 520, rather than with respect to only recalled location 520. This is illustrated in steps 805 and 806, which expand upon how the first group of beams (g_1) is determined. The method of FIG. 8 is described below with reference to FIGS. 5A, 5B, 6A and 6B.

The first step, 804, is recalling the location of user terminal 124 at time t_1 . This is the same as step 704.

Steps 805 and 806 expand upon how the first group of beams (g_1) is determined in step 706. In step 805, an area 522 is determined based on recalled

location 520. This area 522 represents a geographic region within which user terminal 124 is likely to be located at time t_2 . Area 522 can have a defined radius 524 originating at recalled location 520. Radius 524 can have a fixed predetermined value, such as 100 miles. Alternatively, radius 524 can be a function of the time period between time t_1 and time t_2 . An example algorithm for determining radius 524 is:

$$R = (t_2 - t_1) \times D$$

where

- 10 R is radius 524;
 $t_2 - t_1$ is the time period (in hours) since user terminal 124 was located at first location 520; and
D is the maximum distance that it is assumed user terminal 124 could have
15 traveled in one hour (for example, at a velocity of 60 miles an hour).

Using this example algorithm, if the time period between time t_1 and time t_2 is 2 hours, and D is assumed to be 60 miles in one hour, then R is 120 miles. Of course, D can have another predetermined value or can be specific to each user
20 terminal, as would be understood by those skilled in the art.

After area 522 is determined, beams having a coverage area that covers all locations within area 522 at time t_2 are selected or determined in step 806. As discussed above, this is determined using knowledge of the satellite constellation, including the beam coverage areas of the satellites at different
25 points in time. These beams shall be referred to as the first group of beams (g_1). The first group of beams represents those beams that can be used to page user terminal 124 at any location within area 522. For the example of FIGS. 5A and 5B, the first group of beams includes only beam 406. Even though beams 503 and 511 also cover recalled location 520, they do not cover all locations within
30 area 522. As discussed above, area 522 represents a geographic region within which user terminal 124 is likely to be located at time t_2 . Locations 526 and 528 are two of the indefinite number of locations within area 522. As can be seen from FIG. 5B, only beam 406 covers both locations 526 and 528. In contrast,

beams 511 and 503 each only cover one of the two locations 526 and 528 (that is, beam 511 covers only location 526, and beam 503 covers only location 528). Thus, if a channel of beam 511 was used to page user terminal 124, user terminal 124 would not receive the page if it was located at location 528.

5 Once the first group of beams is determined, gateway 122 determines a strongest beam of the first group of beams, in step 808. In one embodiment, the determined strongest beam is the beam that theoretically has a highest power relative to a majority of locations within area 522 at time t_2 . FIG. 5B illustrates the theoretical relative powers of beams 406, 503 and 511. Referring to FIG. 5B, beam
10 406 has the highest power relative to a majority of locations (actually, all locations) within area 522 at time t_2 .

 In step 809, a second group (g_2) of beams is determined. This second group includes all beams having a coverage area that covers "any location" within area 522. In other words, the second group of beams includes any beam
15 having a coverage area that overlaps (or intersects) at least a portion of area 522. This group represents those beams that user terminal 124 may be monitoring if user terminal 124 is actually located, as assumed, within area 522. Referring to FIGS. 5A and 5B, the second group of beams includes beams 406, 503 and 511.

 In step 810, a determination is made whether or not the strongest beam
20 determined in step 808 theoretically has a power that is at least a predetermined amount of power higher than each other beam of the second group of beams relative to all locations within area 522. This step can be accomplished by determining the theoretical power, relative to all locations within area 522, for each beam of the second group of beams.

25 Assume again the predetermined amount of power is 3 or 4 dB. If the strongest beam determined in step 808 is theoretically at least 3 dB stronger than the power of each other beam of the second group of beams for all locations within area 522, then the probability is high that user terminal 124 is monitoring the beam determined in step 808. Accordingly, if the answer in step 810 is YES,

then in step 812 a page is sent from gateway 122 to user terminal 124 on a paging channel of the strongest beam determined in step 808.

For the example shown in FIG. 5B the strongest beam 406 is not theoretically at least 3 dB stronger than beams 503 and 511 for every location
5 within area 522. For example, at location 526, beam 406 is theoretically only 2 dB stronger than beam 511 (the difference between -4 dB and -2 dB) at time t_2 . Thus, for this example the answer in step 810 is NO.

It is noted that steps of the method of the present invention can be performed in a different order and/or combined, without departing from the
10 spirit and scope of the present invention. For example, steps 808 and 810 can be combined into one step. That is, the first group of beams determined in step 806 and the second group (g_2) of beams determined in step 809 can be determined without specifically determining a theoretically strongest beam of the first group of beams. Then, in a step combining steps 808 and 810, a determination can be
15 made whether or not a single beam, of the first group of beams, theoretically has a power at time t_2 that is at least a predetermined amount of power higher at all locations within area 522 than any other beam of the second group of beams. If such a single beam does exist then this single (strongest) beam is used to page user terminal 124 in step 812.

20 If the answer in step 810 is NO, then a time t_3 is determined in step 814. Time t_3 is a time, later in time than time t_2 , at which one beam covering all locations within area 522 will theoretically have a power at all locations within area 522 that is at least the predetermined amount of power higher (for example, 3 dB) than any other beam. Step 814 is similar to step 714 discussed above except
25 that the determined one beam must have a theoretical power that is at least the predetermined amount of power higher for "all locations" within area 522 rather than just for recalled location 520. Referring specifically to FIG. 6B, it can be seen that beam 406 will be at least 3 dB stronger than beam 511 with respect to all locations within area 522 at determined time t_3 .

It is noted that if the difference between time t_2 and t_3 is significant, then the area 522 within which user terminal 124 is assumed to be located can be increased. That is, it is assumed that a user terminal can move farther from a previous known location with the passage of time. Accordingly, in one
5 embodiment of the present invention, the size of area 522 increases as the time between t_2 and t_3 increases.

Next, in step 816, a page is sent from gateway 122 to user terminal 124 on a paging channel of the one beam (determined in step 814) at time t_3 . In one embodiment, this one beam is selected from the first group of beams including
10 the strongest beam determined in step 808. In another embodiment, this one beam is selected from any of the total number of 'm' beams produced by all of the satellites of communications system 100. By waiting until one beam has a power that is theoretically a predetermined amount of power higher at all locations within area 522 than any other beam covering any location within area
15 522, the probability is increased that user terminal 124 (regardless of its location within area 522) is actually monitoring a paging channel of that one beam when a page is sent.

In one embodiment, during the method described in FIG. 8, user terminal 124 performs the same steps discussed above in the description of FIG. 7B. That
20 is, user terminal 124 continually monitors a channel of the beam that is actually strongest with respect to its current location. If user terminal 124 is actually located within area 522 (determined by gateway 122 in step 805), then user terminal 124 should be monitoring a channel of the same beam that gateway 122 uses to send a page in either step 812 or 814.

25 In the above embodiments, if the time periods over which the process extends become excessively or undesirably long, for example t_3 (or subsequent times) also fails, then paging can revert or change to use flood type paging or paging over at least some set of multiple channels (beams) to assure reaching the UT(s). Therefore, single or reduced number of channel pages are used most of
30 the time for reaching or establishing links with most UTs and multiple beam

paging is used only a small portion of the time, achieving a marked reduction in wasted energy or capacity for paging.

**B. User Terminal Monitors Paging Channel of a Theoretically Strongest
5 Beam**

Assume that user terminal 124 is within the coverage area of three beams at time t_2 . In the above discussed embodiments of the present invention, user terminal 124 monitors a channel (for example, a paging channel) of a beam that
10 user terminal 124 determines to actually provide the strongest signal power. Gateway 122 guesses which channel user terminal 124 is monitoring by determining theoretical powers of beams with respect to locations on the surface of the Earth.

In alternative embodiments of the present invention, user terminal 124
15 performs essentially the same algorithm that is performed by gateway 122. That is, using knowledge of the satellite constellation, including the beam coverage areas of the satellites at different points in time, user terminal 124 can determine which beams cover its current location (or recalled location 520) at time t_2 . User terminal 124 can receive the information about the satellite constellation by
20 monitoring channels that broadcast such information from time to time. In these alternative embodiments, user terminal 124 monitors a channel of a theoretically strongest beam rather than an actual strongest beam (this is not to say that the theoretically strongest beam is necessarily different than the actual strongest beam). In this manner, if gateway 122 and user terminal 124 determine that the
25 same beam theoretically has the highest power, then user terminal 124 will receive a page sent by gateway 122. This is regardless of which beam is actually the strongest beam with respect to a current location of user terminal 124. In one embodiment, user terminal 124 can determine the theoretically strongest beam with respect to its current location. Alternatively, if user terminal 124 keeps
30 track of when it last communicated with gateway 122, then user terminal 124 can determine the theoretically strongest beam with respect to a recalled location.

FIGS. 9 and 10 provide a high level description of the alternative embodiments of the present invention. More specifically, FIGS. 9 and 10 includes steps that can be performed by user terminal 124 in place of the steps in FIG. 7B. As was true for the steps of FIG. 7B, the steps of FIGS. 9 and 10 can be performed by user terminal 124 concurrently with either the method described in FIG. 7A or the method described in FIG. 8.

Referring first to FIG. 9, in step 904 user terminal 124 determines a beam that theoretically has the highest power with respect to its current location. In step 906, user terminal 124 monitors a channel of the theoretically strongest beam determined in step 904. User terminal 124 continually performs these steps such that it is always monitoring a channel of the beam that is theoretically strongest with respect to its current location. If user terminal 124 is within area 522 determined by gateway 122 in step 805, then user terminal 124 should be monitoring a page channel of the same beam that gateway 122 uses to send a page in either step 812 or 814.

Referring to FIG. 10, in step 1004 user terminal 124 determines a theoretically strongest beam with respect to a recalled location. In one embodiment, the recalled location is the location at which user terminal 124 was located during its last communication with gateway 122. In the example of FIGS. 5A and 5B, if user terminal 124 last communicated with gateway 122 at time t_1 , then the recalled location is location 520. In step 1006, user terminal 124 monitors a channel of the theoretically strongest beam determined in step 1004.

In each of the above discussed embodiments, if user terminal 124 receives the page it sends an acknowledgment message to gateway 122 indicating that it has received the page. In a preferred embodiment, user terminal 124 sends this acknowledgment message as an access signal or probe over an access channel that is associated with a paging channel over which user terminal 124 received the page.

As discussed above, gateway 122 may calculate the location of user terminal 124 based on either the characteristics of the acknowledgment message

and/or the information included in the acknowledgment message. Once gateway 122 has determined the location of user terminal 122, a table or database of information including the locations of user terminals at different points in time can be updated. Furthermore, the location information may be forwarded
5 to another facility, such as a truck dispatcher facility, or a central system controller.

Of course the page could have been sent for a reason other than requesting a position update, such as to notify user terminal 122 that a voice call is coming in. If this is the case, once gateway 122 receives an acknowledgment
10 from user terminal 124, gateway 122 can send an additional page which instructs user terminal 124 to switch to a specific traffic channel to thereby receive the voice call, or other communication. A person skilled in the relevant art will recognize that a page may have been used for other purposes without departing from the spirit and scope of the present invention.

15 The present invention can reduce the number of paging channels used to page a user terminal by an order of magnitude or more compared to conventional flood paging techniques. Conventional satellite communications systems often page a user terminal over as many as thirty paging channels. The present invention can page a user terminal using a single channel. In addition,
20 this technique can further reduce the number of paging channels used by a factor of around 2 or 3 when compared to the previous improvement in paging as disclosed in "*Apparatus And Method For Paging*" incorporated above.

The previous description of the preferred embodiments is provided to enable any person skilled in the art to make or use the present invention. While
25 the invention has been particularly shown and described with reference to preferred embodiments thereof, it will be understood by those skilled in the art that various changes in form and details may be made therein without departing from the spirit and scope of the invention.

30 **What I claim as my invention is:**

CLAIMS

1. A method for sending a page to a user terminal (UT) in a satellite
2 communications system having at least one gateway and one or more satellites,
wherein each satellite produces a plurality of beams and each beam includes a
4 plurality of channels, and wherein the satellites produce a total number of
beams m , the method comprising the steps of:
 - 6 (a) recalling a location of the UT corresponding to a known location of
the UT at a time t_1 ;
 - 8 (b) determining a group (g_1) of beams that covers said recalled location
of the UT at a time t_2 , where $g_1 < n$ and $t_2 > t_1$;
 - 10 (c) determining a strongest beam of said group (g_1) of beams at time t_2 ;
and
 - 12 (d) sending the page from the gateway to the UT on a channel of said
strongest beam.
2. The method of claim 1, wherein step (c) comprises determining
2 which beam of said group (g_1) of beams theoretically has a highest power relative
to said recalled location at time t_2 .
3. The method of claim 2, wherein step (d) is only performed if said
2 strongest beam theoretically has a power that is at least a predetermined amount
higher than each other beam of said group (g_1) of beams relative to said recalled
4 location.
4. The method of claim 3, further comprising the steps of:
 - 2 (e) determining a time t_3 , where $t_3 > t_2$, at which one beam covering
said recalled location will theoretically have a power that is at least said
4 predetermined amount of power higher than any other beam covering said
recalled location; and

6 (f) sending the page over a channel of said one beam at time t_3 ,
wherein steps (e) and (f) are performed only if said strongest beam at time
8 t_2 did not theoretically have a power that was at least said predetermined
amount of power higher than any other beam of said group (g_1) of beams.

2 5. The method of claim 4, wherein said one beam is selected from said
group (g_1) of beams including said strongest beam.

2 6. The method of claim 4, wherein said one beam is selected from any
of the total number of m beams produced by the one or more satellites.

2 7. The method of claim 1, wherein said channel of said strongest
beam comprises a paging channel.

2 8. The method of claim 1, wherein step (b) comprises:
determining an area, based on said recalled location, within which the UT
is assumed to be located at time t_2 ; and
4 determining which of said total number of beams m have a coverage area
that covers all locations within said area.

2 9. The method of claim 8, wherein said area has a defined radius
originating at said recalled location and wherein step (b) further comprises:
determining a time period between time t_1 and time t_2 ; and
4 determining said defined radius as a function of said time period.

2 10. The method of claim 8, wherein step (c) comprises determining
which of said group (g_1) of beams at time t_2 theoretically has a highest power
relative to a majority of locations within said area.

11. The method of claim 8, wherein step (c) further comprises:
2 determining a second group (g_2) of beams, where $g_2 < m$, said second
group (g_2) of beams including all beams that have a coverage area that covers
4 any location within said area; and
determining whether or not said strongest beam theoretically has a power
6 at all locations within said area that is at least a predetermined amount of power
higher than any other beam of said second group (g_2) of beams.

12. The method of claim 11, wherein step (d) is only performed if a
2 single beam of said group (g_1) of beams theoretically has a power at all locations
within said area that is at least said predetermined amount of power higher than
4 any other beam of said second group (g_2) of beams.

13. The method of claim 12, further comprising the steps of:
2 (e) determining a time t_3 , where $t_3 > t_2$, at which one beam covering all
locations within said area will theoretically have a power at all locations within
4 said area that is at least said predetermined amount of power higher than any
other beam covering any location within said area; and
6 (f) sending the page over a channel of said one beam at time t_3 ,
wherein steps (e) and (f) are performed only if said strongest beam at time
8 t_2 did not theoretically have a power at all locations within said area that was at
least said predetermined amount of power higher than any other beam of said
10 second group (g_2) of beams.

14. The method of claim 13, wherein said one beam is selected from
2 said group (g_1) of beams including said strongest beam.

15. The method of claim 14, wherein said one beam is selected from
2 any of the total number (m) of beams produced by the one or more satellites.

16. The method of claim 13, wherein said channel of said one beam
2 comprises a paging channel.

17. The method of claim 1, wherein steps (a) through (d) are performed by the gateway or a facility in communications with the gateway, and wherein the following steps are performed by the UT:

continually measuring a strength of each of the m beams that cover the UT, wherein the beams that cover the UT can change over time, and wherein said strength of each of the beams can change over time;

continually determining an actual strongest beam of the beams that cover the UT, wherein said actual strongest beam can change over time; and

continually monitoring a channel of said actual strongest beam.

18. The method of claim 13, wherein steps (a) through (f) are performed by the gateway or a facility in communications with the gateway, and wherein the following steps are performed by the UT:

continually measuring a strength of each of the m beams that cover the UT, wherein the beams that cover the UT can change over time, and wherein said strength of each of the beams can change over time;

continually determining an actual strongest beam of the beams that cover the UT, wherein said actual strongest beam can change over time; and

continually monitoring a channel of said actual strongest beam.

19. The method of claim 1, wherein steps (a) through (d) are performed at the gateway or a facility in communications with the gateway, and wherein the following steps are performed by the UT:

continually determining a current location of the user terminal, wherein said current location can change over time;

continually determining a theoretically strongest beam based on said current location, wherein said theoretically strongest beam can change over time;

and

continually monitoring a channel of said theoretically strongest beam.

20. The method of claim 13, wherein steps (a) through (f) are
2 performed by the gateway or a facility in communications with the gateway, and
wherein the following steps are performed by the UT:

4 continually determining a current location of the user terminal, wherein
said current location can change over time;

6 continually determining a theoretically strongest beam based on said
current location, wherein said theoretically strongest beam can change over time;

8 and

continually monitoring a channel of said theoretically strongest beam.

21. The method of claim 1, wherein steps (a) through (d) are performed
2 by the gateway or a facility in communications with the gateway, and wherein
the following steps are performed by the user terminal at time t_2 :

4 recalling a location of the UT at time t_1 ;

determining a theoretically strongest beam based on said recalled
6 location; and

monitoring a channel of said theoretically strongest beam at time t_2 .

22. A method for sending a page to a user terminal (UT) in a satellite
2 communications system having a gateway and one or more satellites, wherein
each satellite produces a plurality of beams and each beam includes a plurality of
4 channels, and wherein the one or more satellites produce a total number of m
beams, comprising the steps of:

6 (a) recalling a location of the UT, said recalled location corresponding
to known location of the UT at a time t_1 ;

8 (b) determining an area, based on said recalled location, within which
the UT is assumed to be located at time t_2 ;

10 (c) determining a group (g_1) of beams having a coverage area that
covers all locations within said area at a time t_2 , where $g_1 < m$ and $t_2 > t_1$;

12 (d) determining a strongest beam of said group (g_1) of beams, said
strongest beam theoretically having the highest power with respect to said
14 recalled location at time t_2 ,

wherein steps (a) through (d) are performed at both the gateway and the
16 UT;
(e) listening, at the UT, to a particular channel of said strongest beam;
18 and
(f) sending a page from the gateway to the UT on said particular
20 channel of said strongest beam at time t_2 .

23. The method of claim 22, wherein said area has a defined radius
2 originating at said recalled location and wherein step (b) comprises:
determining a time period between time t_1 and time t_2 ; and
4 determining said defined radius as a function of said time period.

24. A system for sending a page to a user terminal (UT) in a satellite
2 communications system having a gateway and one or more satellites, wherein
each satellite produces a plurality of beams and each beam includes a plurality of
4 channels, and wherein the one or more satellites produce a total number of m
beams, the system comprising:
6 means for recalling a location of the UT, said recalled location
corresponding to a known location of the UT at a time t_1 ;
8 means for determining a group (g_1) of beams that covers said recalled
location of the UT at a time t_2 , where $g_1 < m$ and $t_2 > t_1$;
10 means for determining a strongest beam of said group (g_1) of beams at
time t_2 ; and
12 means for sending the page from the gateway to the UT on a channel of
said strongest beam.

25. The system of claim 24, wherein said strongest beam is a beam of
2 said group (g_1) of beams that theoretically has a highest power relative to said
recalled location at time t_2 .

26. The system of claim 25, wherein said means for sending the page
2 only sends the page at time t_2 if said strongest beam theoretically has a power

that is at least a predetermined amount of power higher than each other beam of
4 said group (g_i) of beams relative to said recalled location.

27. The system of claim 26, further comprising:
2 means for determining a time t_3 , where $t_3 > t_2$, at which one beam covering
said recalled location will theoretically have a power that is at least said
4 predetermined amount of power higher than any other beam covering said
recalled location,

6 wherein said means for sending the page sends the page over a channel of
said one beam at time t_3 if said strongest beam at time t_2 did not theoretically
8 have a power that was at least said predetermined amount of power higher than
any other beam of said group (g_i) of beams.

28. The system of claim 27, wherein said one beam is selected from
2 said group (g_i) of beams including said strongest beam.

29. The system of claim 27, wherein said one beam is selected from any
2 of the total number (m) of beams produced by the one or more satellites.

30. The system of claim 24, wherein said channel of said strongest
2 beam comprises a paging channel.

31. The system of claim 24, wherein said means for determining said
2 group (g_i) of beams comprises:

means for determining an area, based on said recalled location, within
4 which the UT is assumed to be located at time t_2 ; and

means for determining which of said total number of m beams have a
6 coverage area that covers all locations within said area.

32. The system of claim 31, wherein said area has a defined radius
2 originating at said recalled location, and wherein said defined radius is a
function of a time period between time t_1 and time t_2 .

2 33. The system of claim 31, wherein said strongest beam is a beam of
said group (g_1) of beams that theoretically has a highest power relative to a
majority of locations within said area at time t_2 .

2 34. The system of claim 31, further comprising:
means for determining a second group (g_2) of beams, where $g_2 < m$, said
second group (g_2) of beams including all beams that have a coverage area that
4 covers any location within said area; and

6 means for determining whether or not said strongest beam theoretically
has a power at all locations within said area that is at least a predetermined
amount of power higher than any other beam of said second group (g_2) of beams.

2 35. The system of claim 34, wherein said means for sending the page
only sends the page at time t_2 if said strongest beam at time t_2 theoretically has a
power at all locations within said area that is at least said predetermined amount
4 of power higher than any other beam of said second group (g_2) of beams.

2 36. The system of claim 35, further comprising:
means for determining a time t_3 , where $t_3 > t_2$, at which one beam covering
all locations within said area will theoretically have a power at all locations
4 within said area that is at least said predetermined amount of power higher than
any other beam covering any location within said area,
6 wherein said means for sending the page sends the page over a channel of
said one beam at time t_3 , if said strongest beam at time t_2 did not theoretically
8 have a power at all locations within said area that was at least said
predetermined amount of power higher than any other beam of said second
10 group (g_2) of beams.

2 37. The system of claim 36, wherein said one beam is selected from
said group (g_1) of beams including said strongest beam.

38. The system of claim 36, wherein said one beam is selected from any
2 of the total number of m beams produced by the one or more satellites.

39. The system of claim 36, wherein said channel of said one beam
2 comprises a paging channel.

40. The system of claim 24, wherein the UT comprises:
2 means for continually measuring a strength of each of the m beams that
cover the UT, wherein the beams that cover the UT can change over time, and
4 wherein said strength of each of the beams can change over time;
means for continually determining an actual strongest beam of the beams
6 that cover the UT, wherein said actual strongest beam can change over time; and
means for continually monitoring a channel of said actual strongest beam.

41. The system of claim 36, wherein the UT comprises:
2 means for continually measuring a strength of each of the m beams that
cover the UT, wherein the beams that cover the UT can change over time, and
4 wherein said strength of each of the beams can change over time;
means for continually determining an actual strongest beam of the beams
6 that cover the UT, wherein said actual strongest beam can change over time; and
means for continually monitoring a channel of said actual strongest beam.

42. The system of claim 24, wherein the UT comprises:
2 means for continually determining a current location of the user terminal,
wherein said current location can change over time;
4 means for continually determining a theoretically strongest beam based
on said current location, wherein said theoretically strongest beam can change
6 over time; and
mean for continually monitoring a channel of said theoretically strongest
8 beam.

43. The system of claim 36, wherein the UT comprises:
2 means for continually determining a current location of the user terminal,
wherein said current location can change over time;
4 means for continually determining a theoretically strongest beam based
on said current location, wherein said theoretically strongest beam can change
6 over time; and
means for continually monitoring a channel of said theoretically strongest
8 beam.

44. The system of claim 24, wherein the UT comprises:
2 means for recalling a previous location of the UT;
means for determining a theoretically strongest beam based on said
4 recalled location; and
means for monitoring a channel of said theoretically strongest beam.

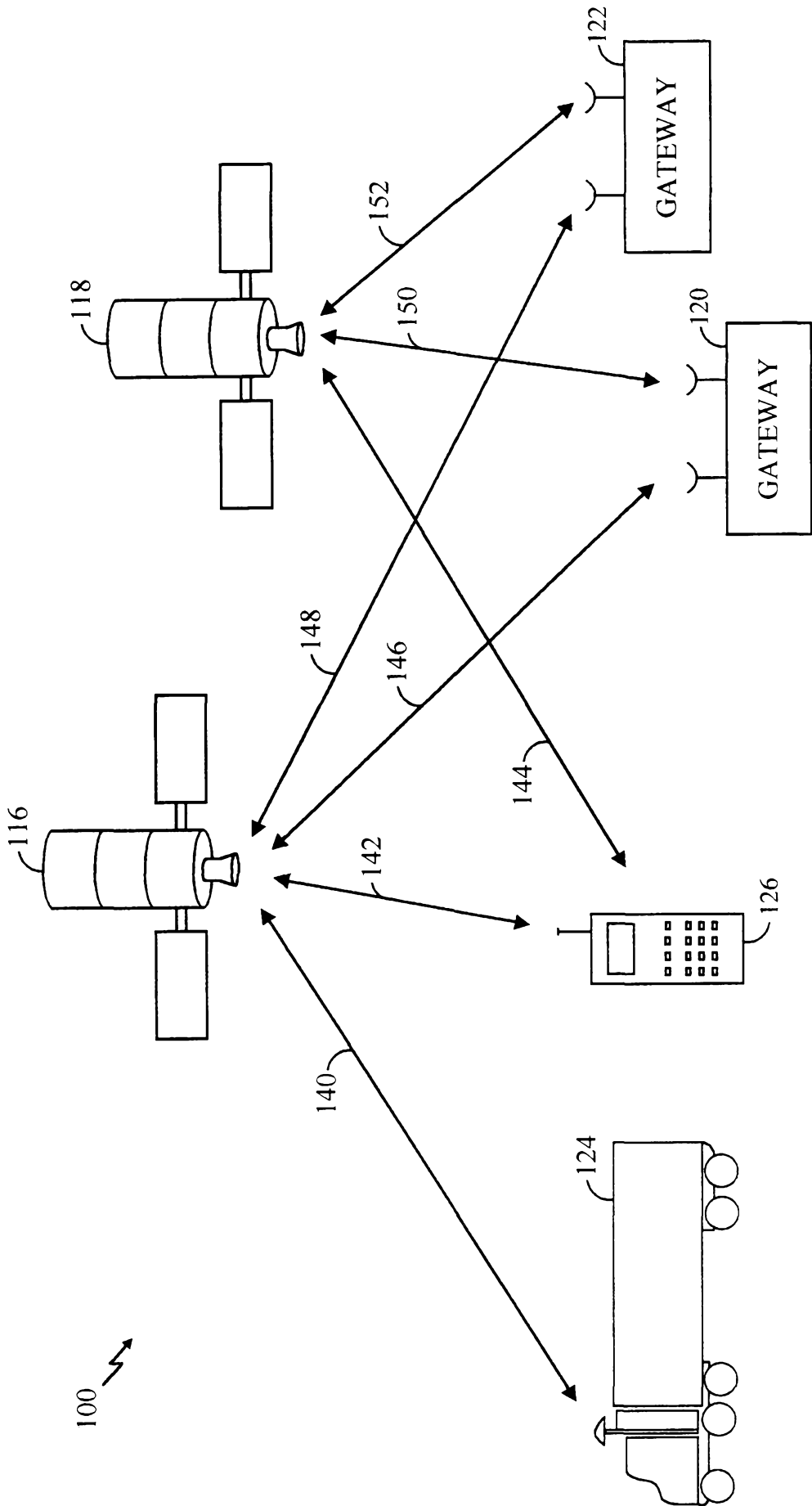

FIG. 1A

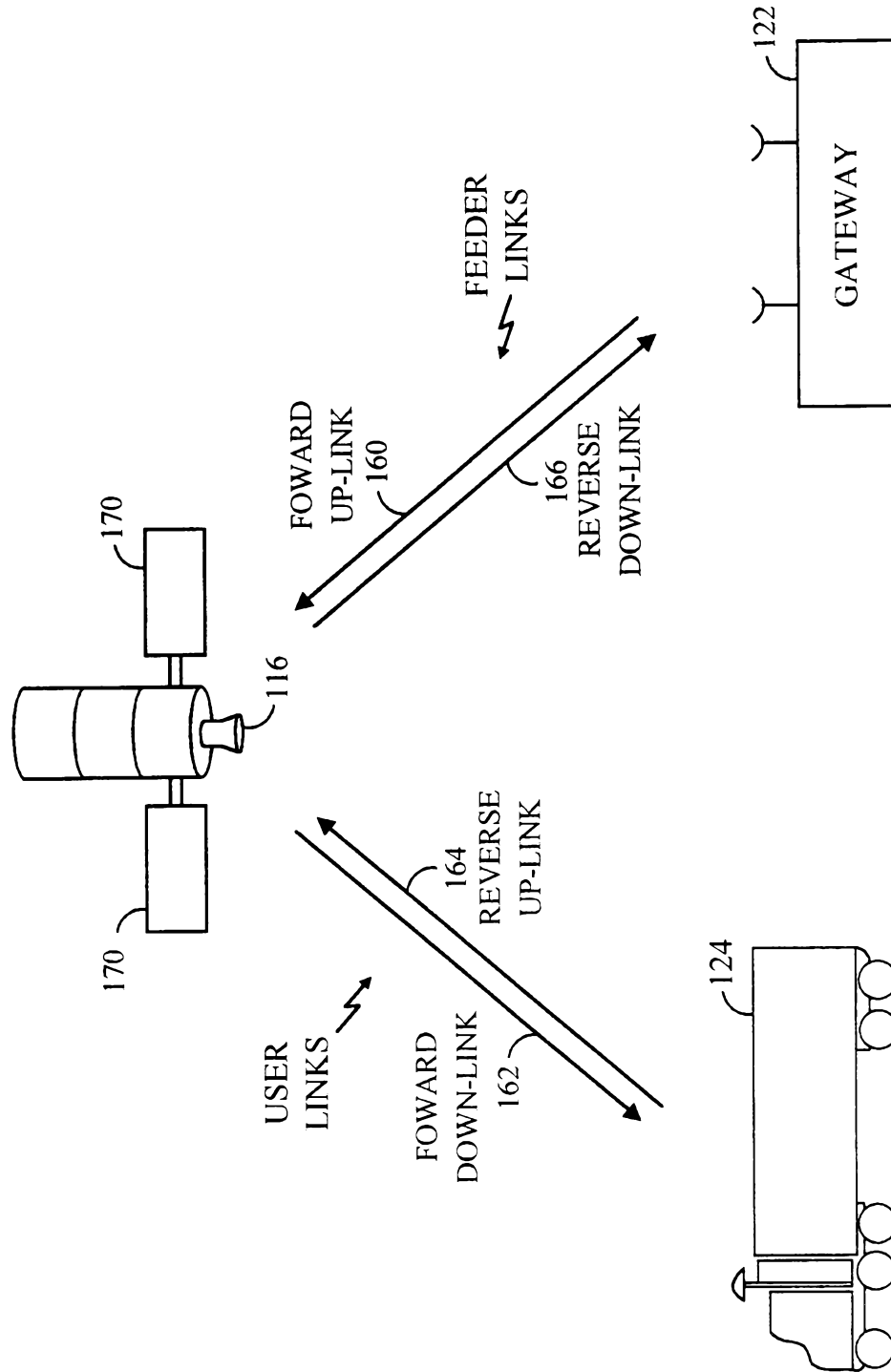

FIG. 1B

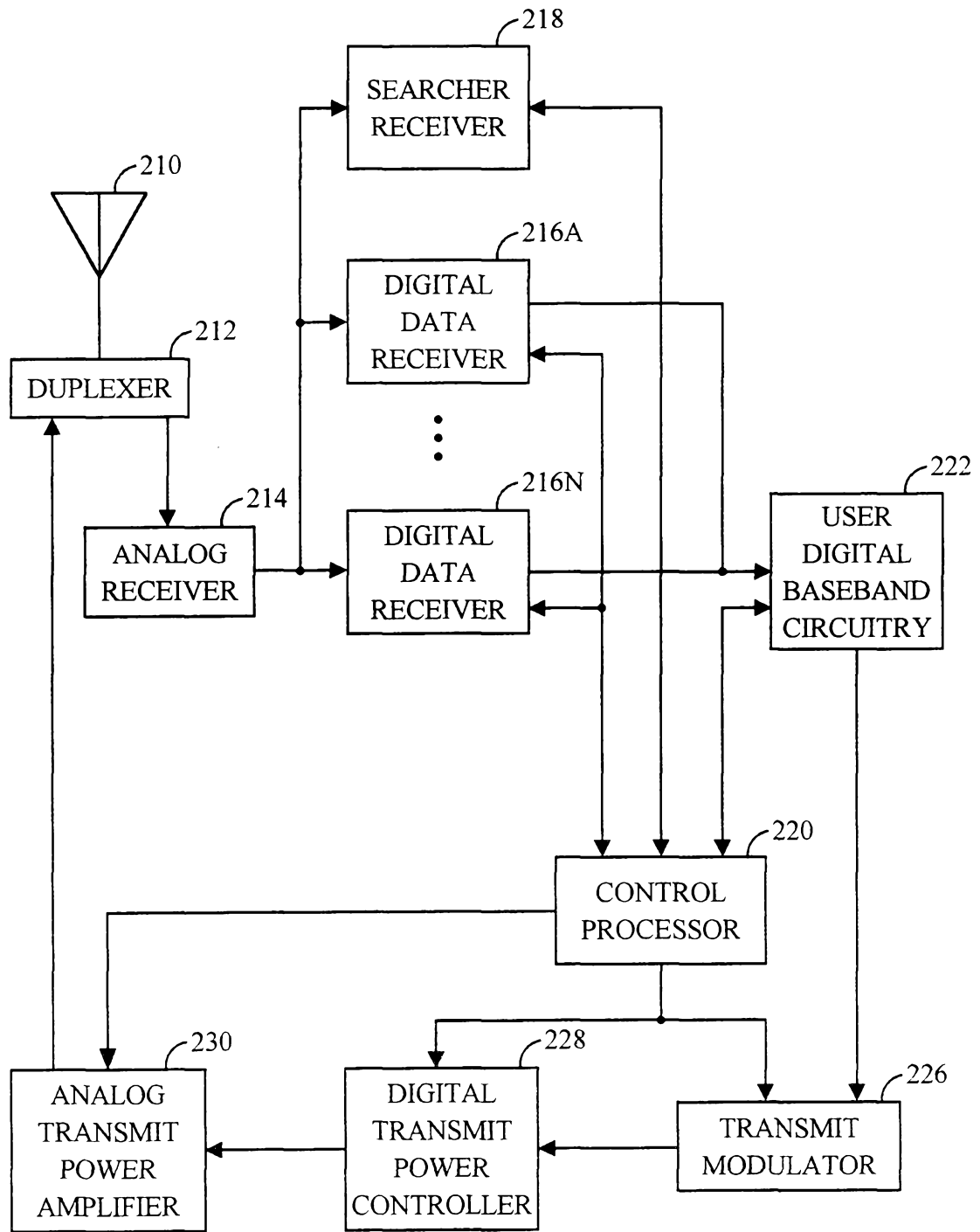
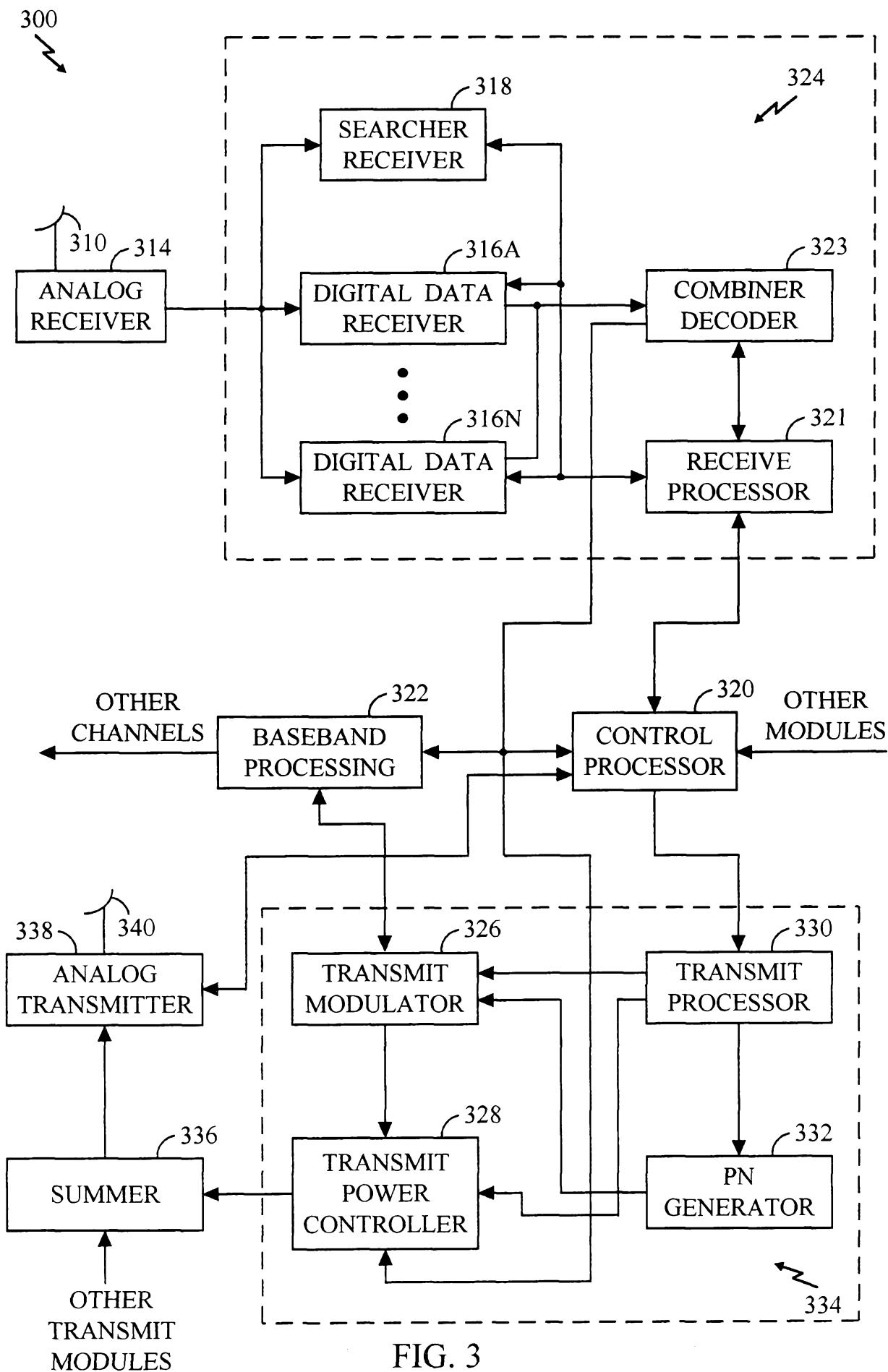

FIG. 2



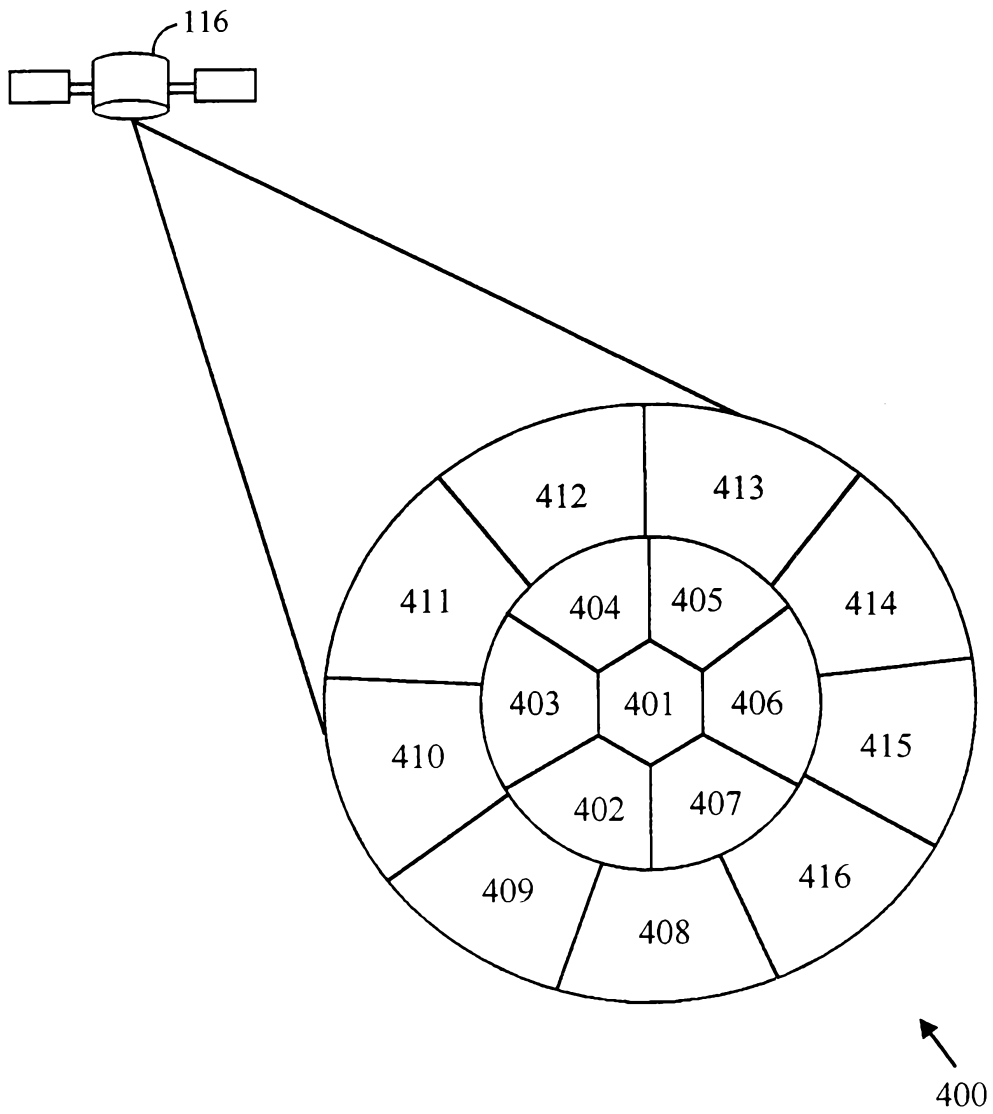

FIG. 4

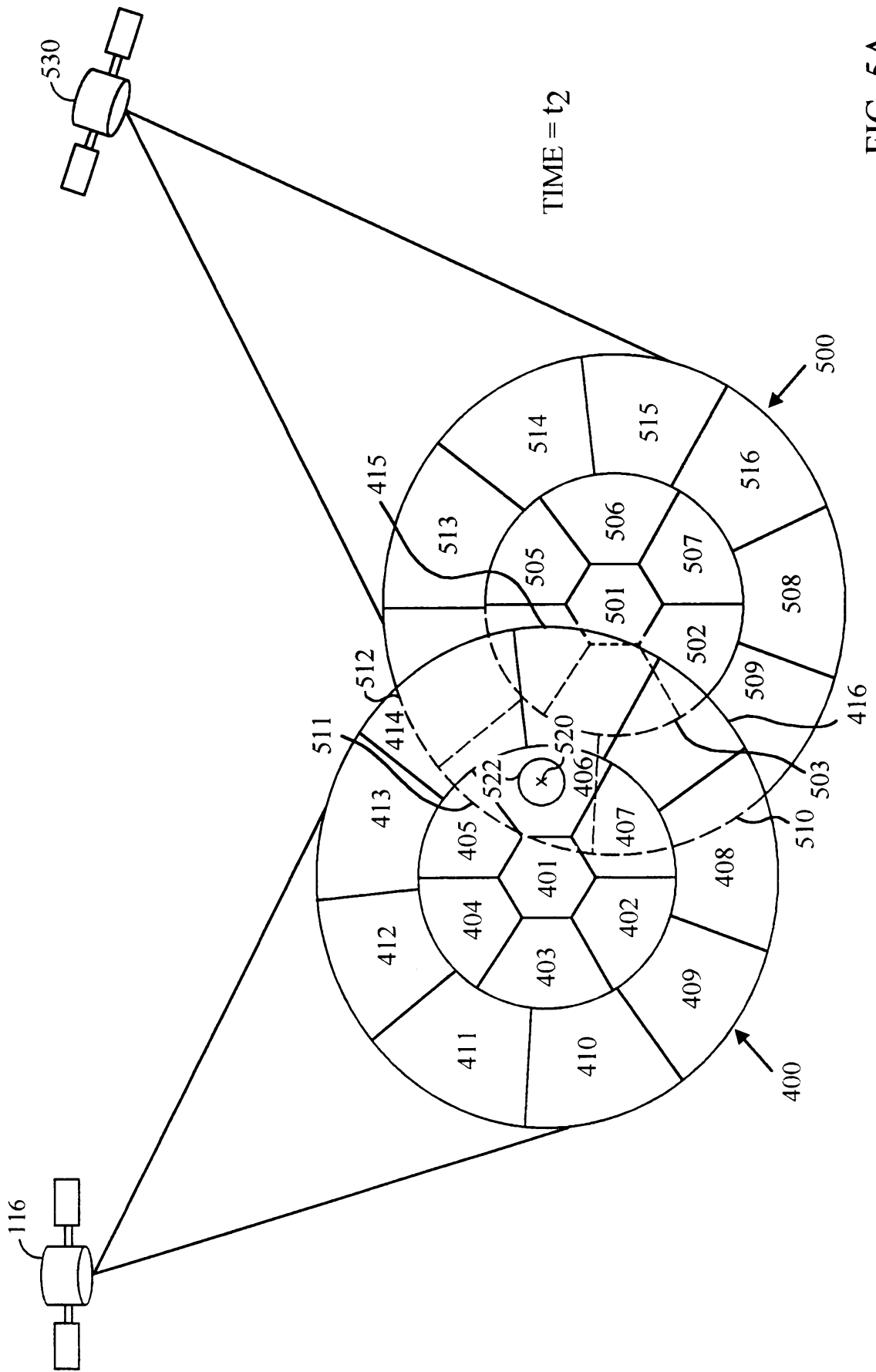

FIG. 5A

TIME = t3

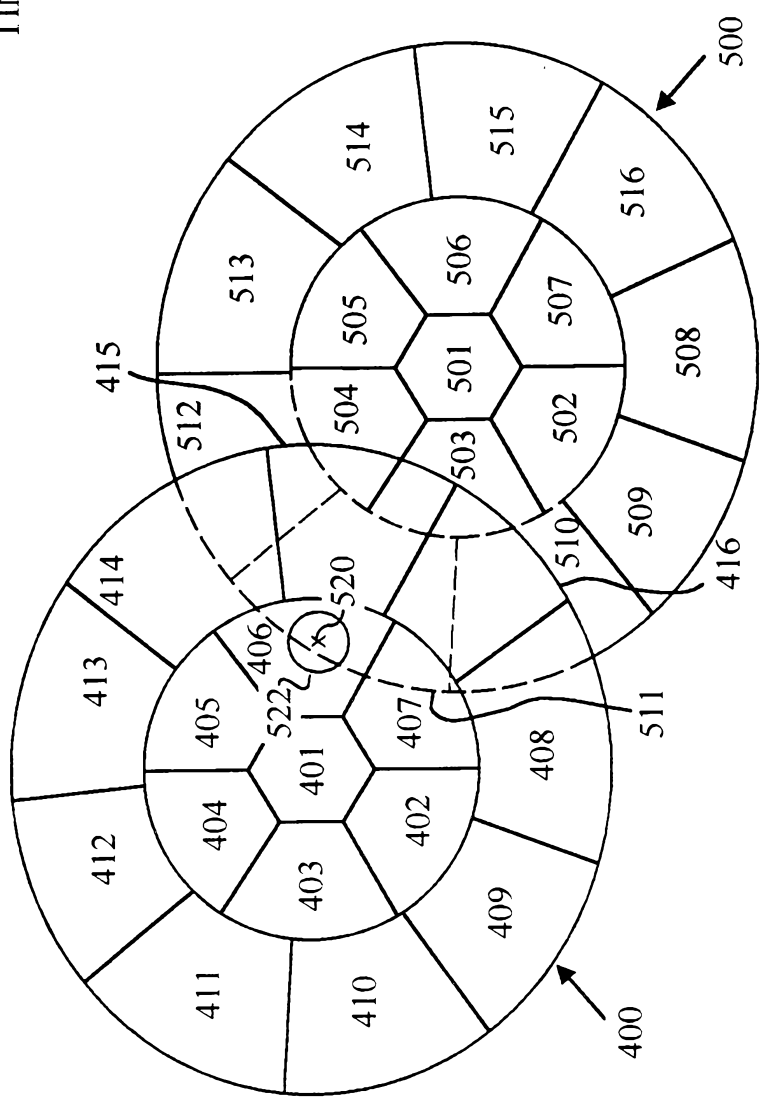

FIG. 6A

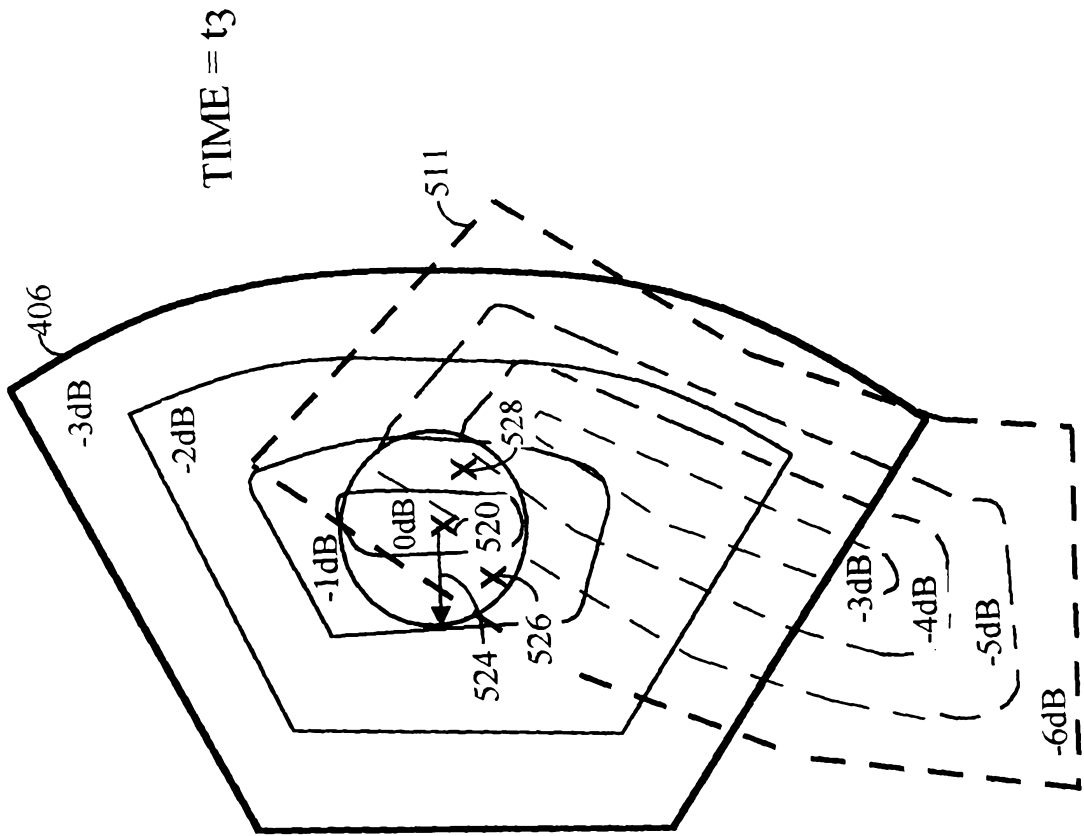

FIG. 6B

10/12

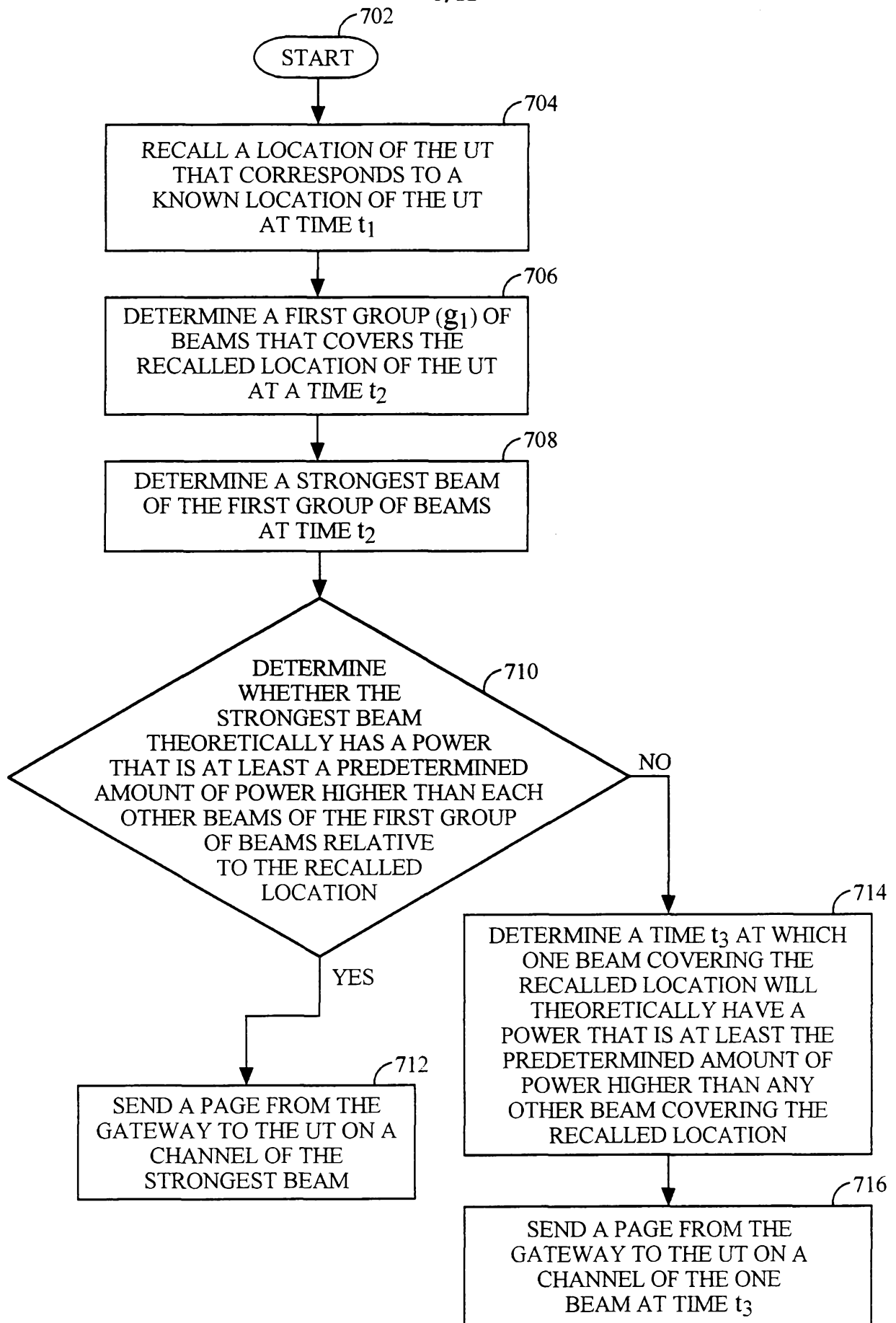

FIG. 7A

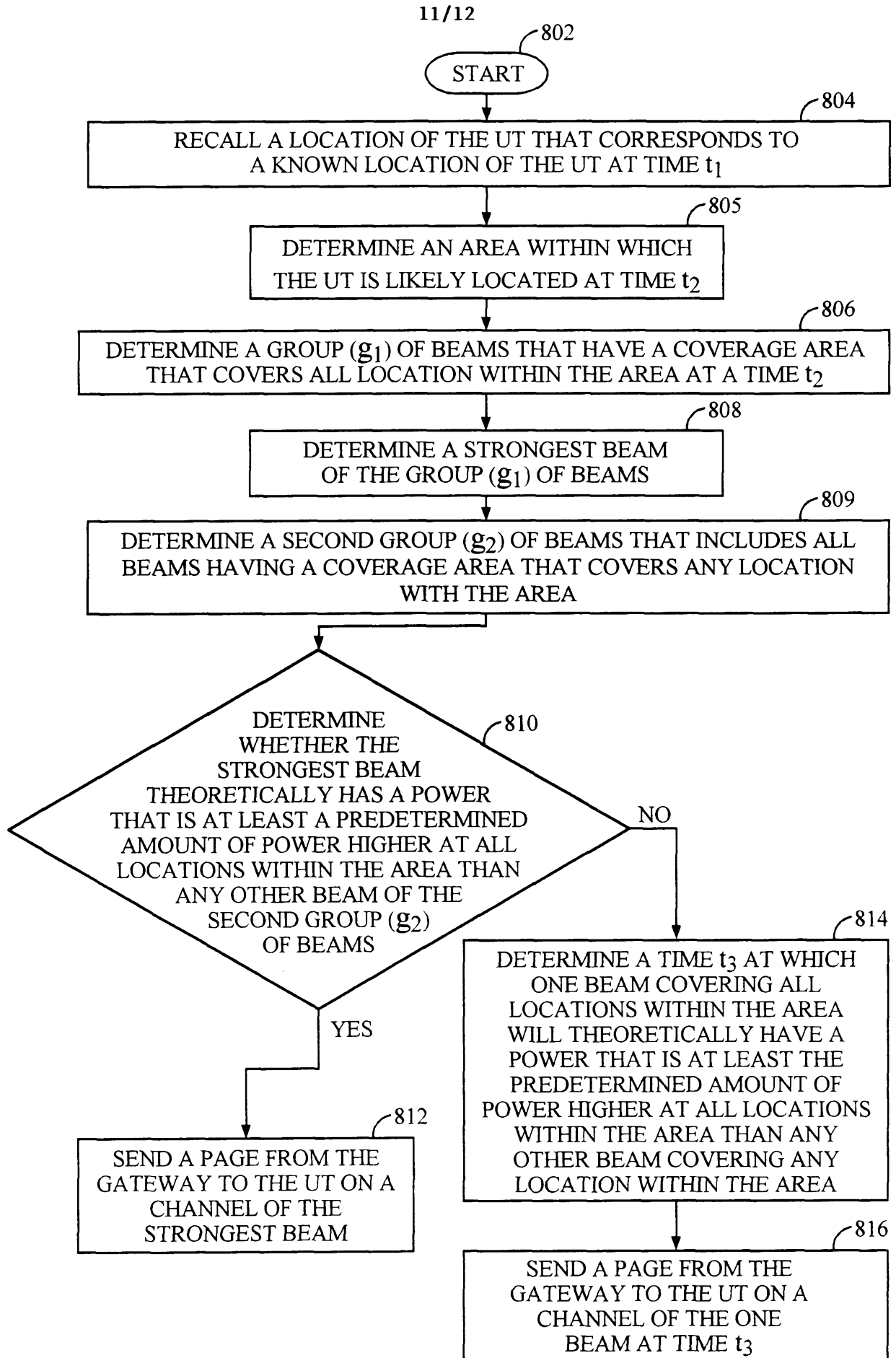

FIG. 8

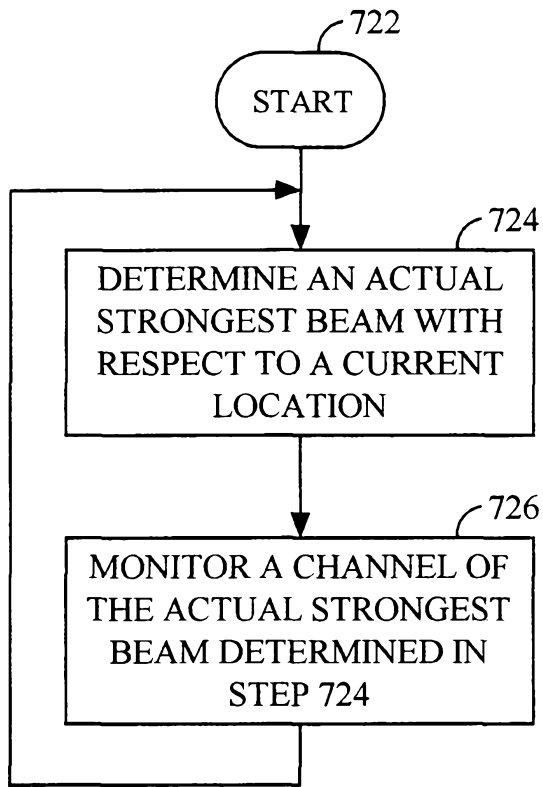

FIG. 7B

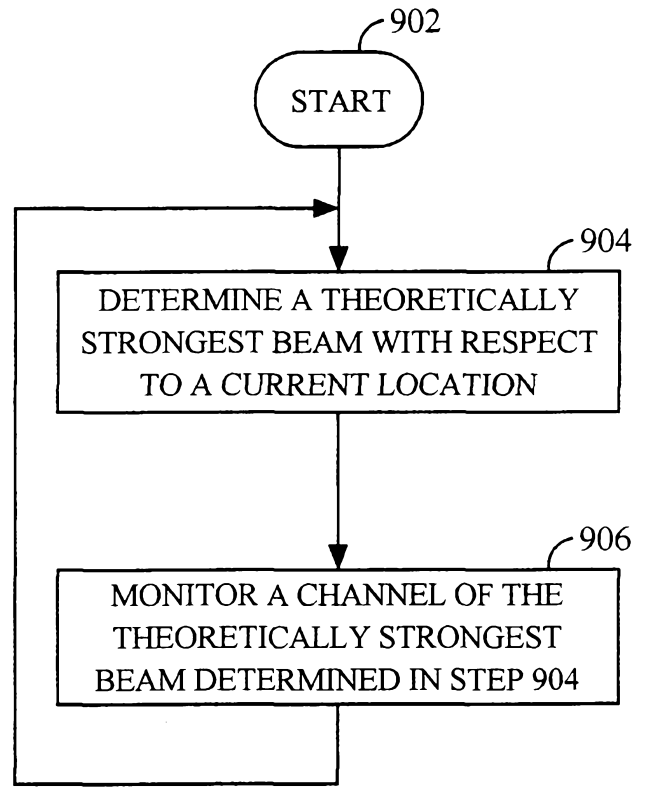

FIG. 9

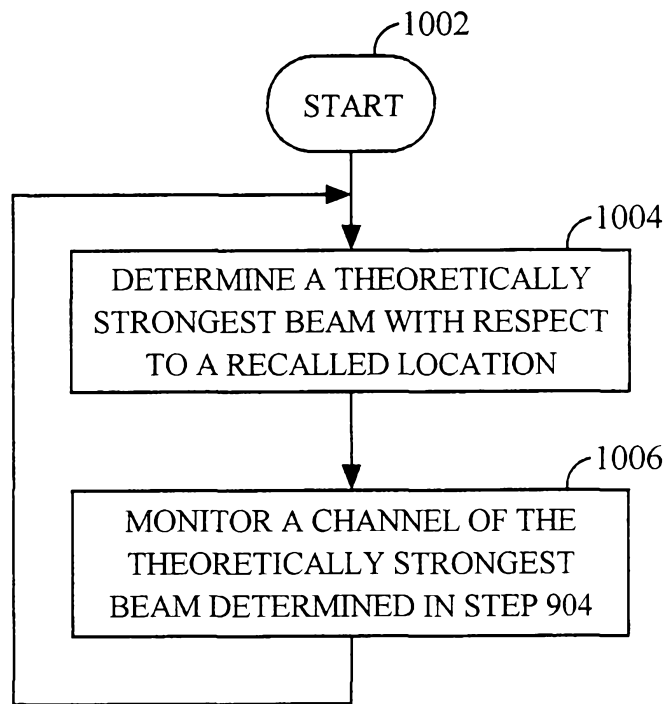

FIG. 10