

[54] DESICCANT END CAP

[75] Inventors: John S. Cullen, Buffalo; Paul W. Huber, Depew, both of N.Y.

Primary Examiner—George E. Lowrance
Attorney, Agent, or Firm—Joseph P. Gastel

[73] Assignee: Multiform Desiccant Products, Inc., Buffalo, N.Y.

[22] Filed: Apr. 1, 1974

[21] Appl. No.: 456,690

[52] U.S. Cl. 206/204; 312/311

[51] Int. Cl.² B65D 81/24

[58] Field of Search 206/204; 312/31, 31.1

[56] References Cited

UNITED STATES PATENTS

2,531,084	11/1950	Sommer.....	312/31.1
2,546,599	3/1951	Hicks.....	312/31.1
2,676,078	4/1954	Young.....	312/31.1
2,690,946	10/1954	Roehrl.....	206/204
2,915,404	12/1959	Tessmer.....	312/31.11
3,583,596	6/1971	Brewer.....	229/43

[57] ABSTRACT

A desiccant end cap for mounting on a hollow cylindrical member having an annular flange with a face portion and an outer annular portion extending transversely thereto comprising a cup-like member having an end portion and an annular rim extending substantially perpendicularly to the end portion for overlying said outer portion of said flange with an interference fit. desiccant container means mounted centrally on said end portion for positioning within said hollow tubular member, spacer dimples on the end portion of said cap for positioning said end portion in spaced relationship to the face portion of the flange, and latching dimples on said rim for engaging said flange with a holding fit.

15 Claims, 8 Drawing Figures

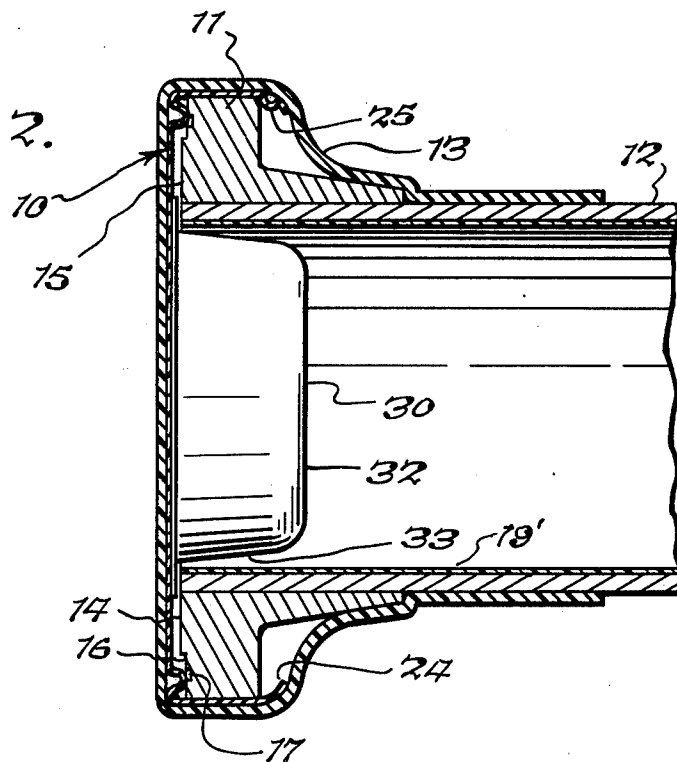

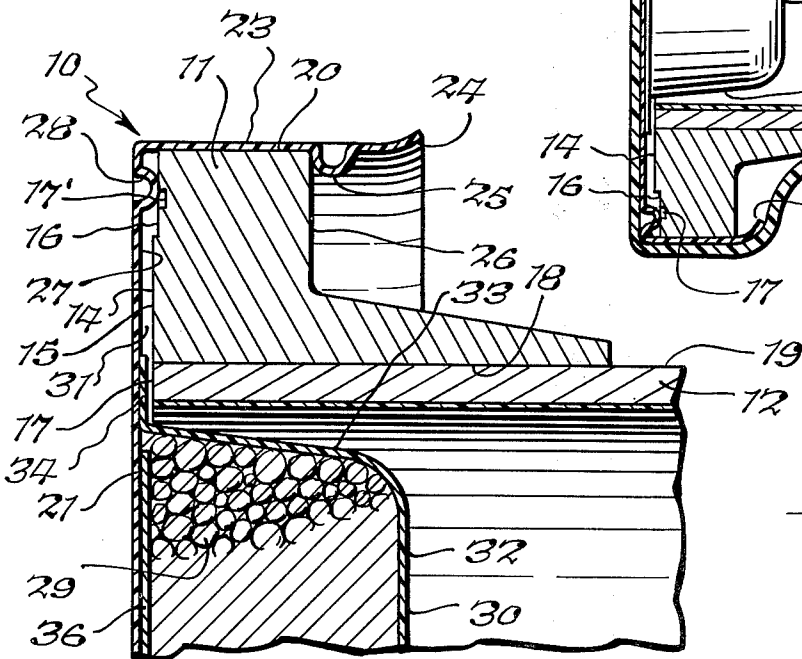
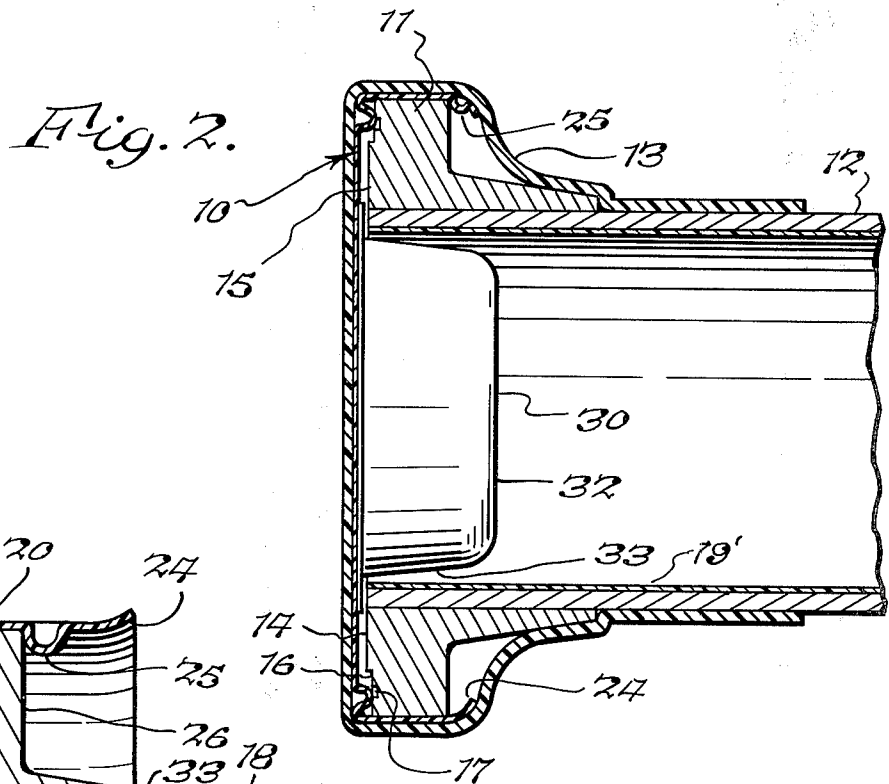
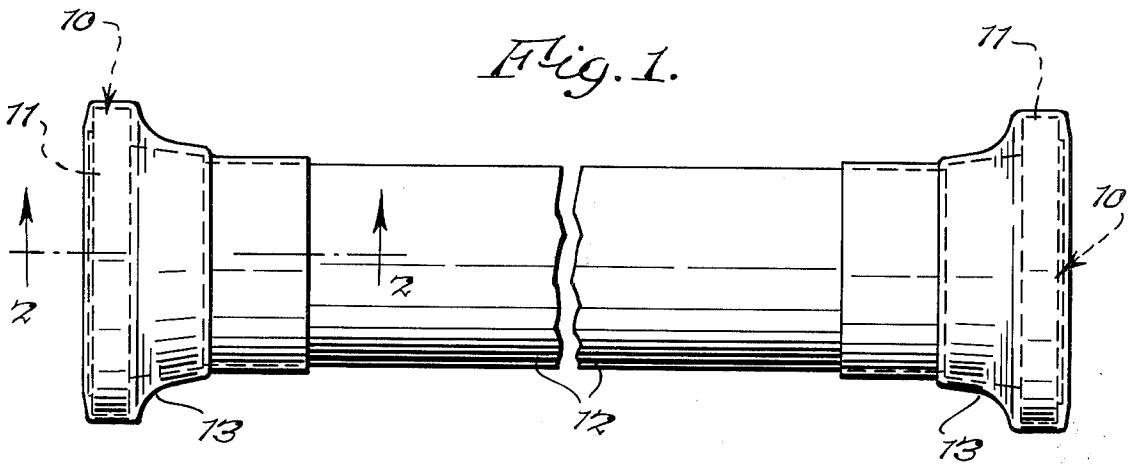
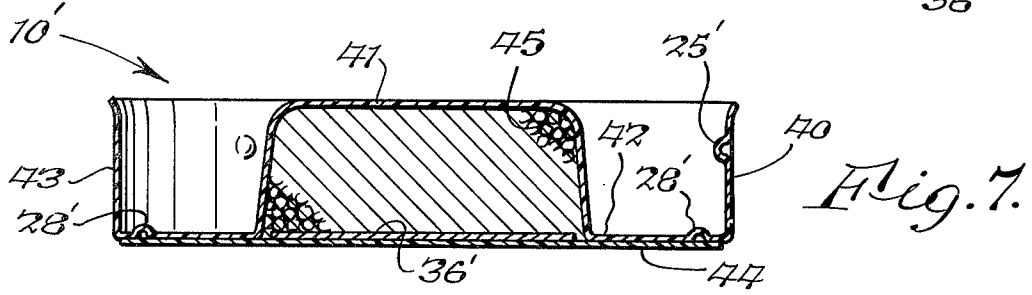
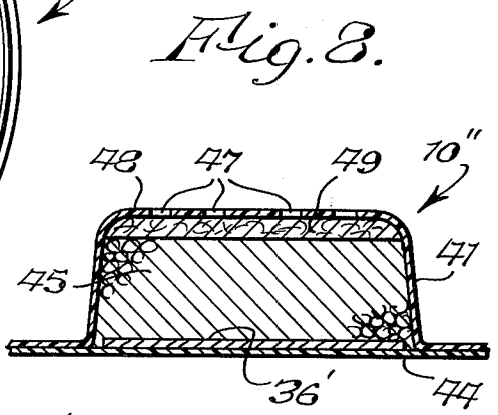
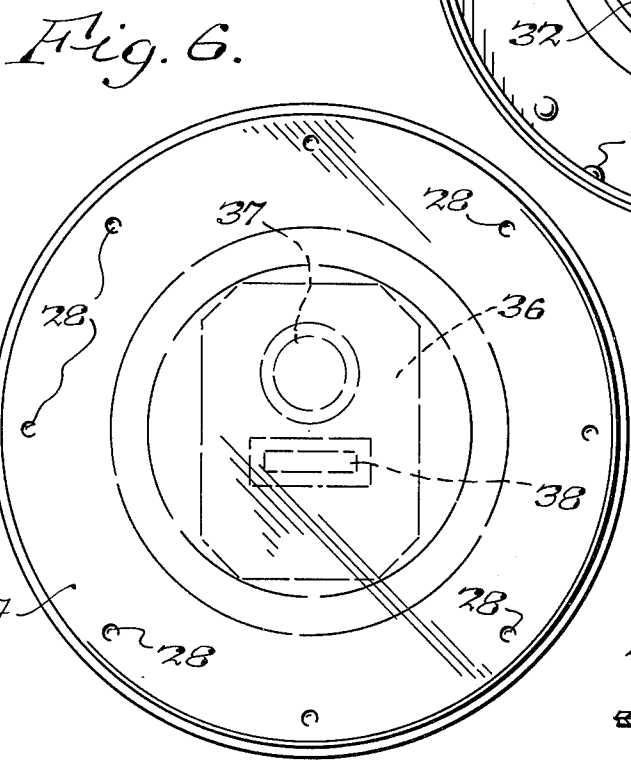
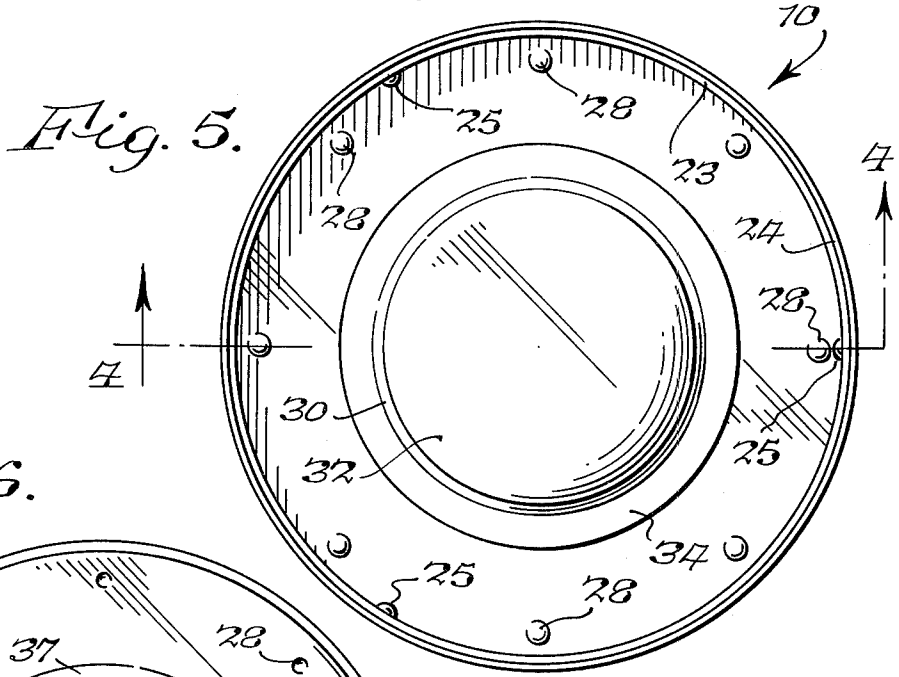
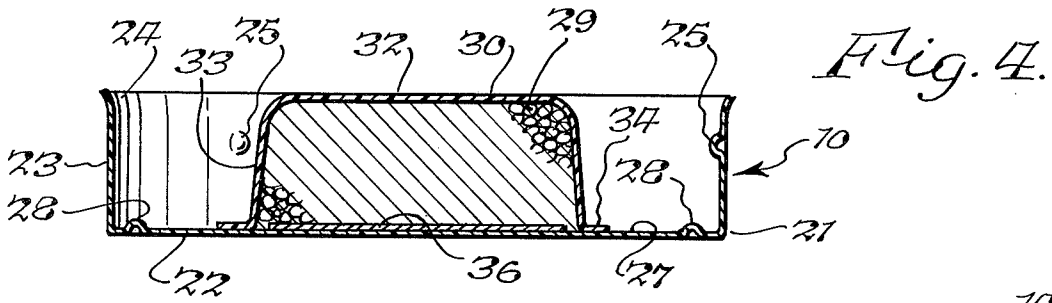

Fig. 3.



DESICCANT END CAP

The present invention relates to a desiccant end cap used for the purpose of preventing the flange on the end of a wave guide tube from being subjected to the effects of moisture.

By way of background, wave guides used in the electronic industry are fabricated by securing adjacent wave guide tubes to each other in substantially perfect alignment. This securing is effected by placing adjacent flanges on the ends of adjacent tubes in a suitable fixture and thereafter welding the ends of the wave guide tubes to each other. In order to obtain substantially perfect alignment, the flanges have surfaces thereon which are machined to very close tolerances and these surfaces are used as reference areas which are engaged by the fixtures. If the reference areas have scale, corrosion or rust thereon, perfect alignment cannot be effected and therefore the wave guide installation will not function properly. In addition, if there is scale, corrosion or rust on the adjacent surfaces of the wave guide tubes which are to be welded to each other, there is the possibility that improper joining will occur.

It is accordingly an important object of the present invention to provide a desiccant end cap for mounting on the flange of a wave guide to protect all portions thereof from the effects of moisture and therefore prevent the formation of scale, corrosion or rust.

Another object of the present invention is to provide a desiccant end cap which can be slipped on and off of the flange of a wave guide in an extremely simple and expedient manner and which, once installed, will remain securely in position until it is purposely removed.

Yet another object of the present invention is to provide a desiccant end cap for the flange of a wave guide which is fabricated in such a manner so that it provides a clearance space between certain portions of the end cap and the adjacent flange so as to permit unimpeded communication between the desiccant carried by the end cap and the various surfaces of the flange.

A still further object of the present invention is to provide a desiccant end cap for a wave guide which is extremely simple in construction and highly reliable in operation. Other objects and attendant advantages of the present invention will readily be perceived hereafter.

The present invention relates to a desiccant end cap for mounting on a member having a face portion and an outer portion extending transversely thereto comprising a cup-like member having an end portion, a rim extending from said end portion for overlying said outer portion of said member, desiccant container means mounted on said end portion, and spacer means for causing said end portion to be oriented in spaced relationship to said face portion to permit communication between said desiccant container means and said face portion.

The various aspects of the present invention will be more fully understood when the following portions of the specification are read in conjunction with the accompanying drawings wherein:

FIG. 1 is a fragmentary side elevational view of a wave guide mounting the desiccant end caps of the present invention at its opposite ends with the end caps being covered by protective boots;

FIG. 2 is a fragmentary cross sectional view taken substantially along line 2—2 of FIG. 1;

FIG. 3 is an enlarged fragmentary cross sectional view similar to FIG. 2 but with the desiccant cup also being in cross section;

FIG. 4 is a cross sectional view of the desiccant end cap taken substantially along line 4—4 of FIG. 5;

FIG. 5 is a plan view of the desiccant end cap looking into the open end thereof;

FIG. 6 is a plan view of the desiccant end cap looking at the outer end thereof;

FIG. 7 is a cross sectional view of a modified type of end cap having an impermeable layer of material secured to the outer end thereof; and

FIG. 8 is a fragmentary cross sectional view of a modified form of desiccant container which may be substituted for the constructions shown in FIGS. 1—7.

The desiccant end cap 10 of the present invention is adapted to be mounted on flanges 11 which are located at the outer end portions of wave guide tube 12. Protective boots 13, which form no part of the present invention, are fabricated from a suitable rubber-like plastic material and are shrunk-fitted over flanges 11 having end caps 10 installed thereon.

By way of background, steel flange 11 mounted on steel wave guide tube 12 includes a face 14 having an annular rib portion 15 extending outwardly from annular portion 16 which has an annular groove 17' therein. Annular rib 15 is flush with the end 17 of the wave guide tube 12. Flange 11 also includes an annular surface 18 which is suitably joined to outer surface 19 of wave guide tube 12 which has a plastic liner 19' therein. In addition, flange 11 includes an outer annular surface 20 which is machined to a very close tolerance as it is used as a reference surface during the joining of adjacent flanges of adjacent wave guides, which must be in substantially perfect alignment. Therefore it is mandatory that outer annular surface 20 be kept free of rust, scale, or any other form of defacing corrosion which could alter its dimensions in any respect, as such alterations could result in an improper alignment between adjacent wave guides. Furthermore, since surfaces 15 and 17 are placed in abutting engagement with like surfaces on an adjacent wave guide when they are joined, they must also be kept free of rust, scale or corrosion, in order to insure their proper alignment and their proper joining by a suitable welding process.

The improved end cap 10 of the present invention protects the end of tube 12, rib 14 and the critical surface 20 of flange 11 from corrosion and foreign matter which could be deposited thereon. End cap 10 includes a flexible body portion 21 in the form of a shallow cup-like member having a circular substantially planar end portion or panel 22 with an integral annular rim 23 extending substantially perpendicularly thereto. An outer flared lip 24 is formed at the open end of rim 23 for guiding cap 10 onto surface 20 of flange 11. The inner diameter of rim 23 engages flange surface 20 with an interference fit so that it is mounted snugly thereon. A plurality of dimples 25 are circumferentially spaced on the inner surface of rim 23 for engaging the rear side 26 of flange 11 with a latching action to retain cap 10 securely in its installed position. Because of the existence of dimples 25, if desired, rim 23 need not provide an interference fit but can have an extremely close fit which is not an interference fit. Also, if desired, under certain conditions it may be permissible to rely only on the interference fit to retain cap 10 in its mounted position, in which event dimples 25 may be omitted. A cup

30, which contains a suitable desiccant 29, is centrally mounted on the inside surface 27 of end panel 22.

In the installed position of cap 10 on flange 11, a clearance space 31 is provided between the inside surface 27 of end portion 22 and the adjacent surfaces of rib 14 and tube end 17. This clearance space is provided by dimples 28 which are circumferentially spaced on end portion 21 and are located proximate rim 23. As can be seen from FIG. 3, except for dimples 28, there is a clearance between all portions on the inside of end portion 22 and the outside of cup 30, on one hand, and the adjacent portions of flange 11 and the end 17 of tube 12, on the other hand. This permits the effect of the desiccant 29 within cup 30 to be unrestrictedly communicated to clearance space 31 to thereby maintain the end surface of flange 11 exposed to a continual drying action. As noted above, the only areas of contact between cap 10 and flange 11 are at rim 23 and at dimples 28. However, because of the fact that rim 23 and dimples 28 are made out of a material which is permeable, the desiccating effect of desiccant 29 is also communicated through the rim 23 to flange surface 20 and through dimples 28 to the portions of surface 16 under dimples 28. Bead silica gel has been found preferable for use as desiccant 29. However, other natural or synthetic desiccants such as granular silica gel, molecular sieve in the form of granules, beads or pellets, montmorillonite, or calcium sulphate are also suitable.

Desiccant cup 30 includes an end wall 32 and a tapered side wall 33 which merges into an annular flange 34 which is secured to surface 27, as by ultrasonic sealing, solvent welding, or suitable adhesive. Tapered side wall 33 aids in guiding cap 10 during installation. In this particular case container 30 is fabricated from cellulose acetate propionate and cup member 21 is fabricated from cellulose acetate butyrate, which is transparent. However, other materials may be used. As noted above, while the material from which cup member 21 is made is permeable so that the absorbing effect of the desiccant can be communicated to surface 20 and the portions of surface 16 against which dimples 28 abut, it is less permeable than the material of cup 30 so as to restrict the transmittal of ambient moisture there-through. As can be seen from FIG. 3, when end cap 10 is in position, it will protect the various covered and confined surfaces which must be protected. In addition, cap 10 may also be removed so as to permit access to the flange or the tube 12, as required. Thus, cap 10 not only provides a desiccating effect during long term storage but it also functions as a short-term desiccant and a dust cover during the time that the wave guide is in the plant during fabrication.

A card 36 is positioned within cup 30 against surface 27 and is visible through the transparent material from which cup member 21 is fabricated so that the color of the cobalt chloride spot 37 may be compared with the color of panel 38 for the purpose of determining the activity of the desiccant in cup 30.

It is to be noted that there is a double layer of material, namely, flange 34 and end portion 21 opposite wave guide 17 so that this material acts as a cushion to prevent marring of end surface 17 in the event that the outer surface of end panel 21 is engaged by a foreign object.

As can be seen from FIG. 2, when the protective boot 13 is shrunk into place, it deforms the flared lip 24, this being possible because of the fact that the plastic from

which rim 23 is fabricated is flexible, as noted above.

The wall thickness of cup 21 is 0.040 inches and the wall thickness of cup 30 is 0.004 inches. Dimples 25 and 28 are hemispherical and have an outer radius of about 0.030 inches. The fact that cup 21 is relatively thick as compared to cup 30 also contributes to a slower rate of permeability through cup 21. If desired, the outside surface of end portion 22 of cup 21 may be painted with an impermeable paint to reduce its permeability.

In FIG. 7 an alternate embodiment of the present invention is disclosed. This embodiment which is designated 10' differs from the embodiments of FIGS. 1-6 in that cap member 40 is suitably formed of one piece of material so as to provide a tapered frustoconical cup portion 41, an annular front portion 42, and a rim 43. Rim 43 has dimples 25' which are analogous to dimples 25 described above. In addition, dimples 28' are provided which are analogous to dimples 28 described above. However, to complete the end cap, an impermeable transparent circular planar disc of material 44 is applied across the end of cap 10' and is attached to annular surface by any suitable means such as ultrasonic sealing, solvent welding, or a suitable adhesive. The fact that disc 44 is impermeable cuts down on the exposure of the desiccant 45 to the area outside of tube 12. An indicator card 36', which is analogous to indicator card 36 of FIG. 8, is secured to the inside surface of disc 44.

In FIG. 8 a still further embodiment of the present invention is disclosed. This embodiment is essentially the same in all respects as the embodiment of FIG. 7 except that the desiccant cup 41 includes a plurality of apertures 47 in the end surface 48 thereof and a porous retentive barrier, namely, a piece of felt 49 covers these apertures to prevent the desiccant 45 from falling out. With the construction of FIG. 8 there is a greater permeability or an improved water vapor transmission rate through cup 41 than is obtainable with the cups of FIGS. 1-7 which are not perforated.

It can thus be seen that the improved end caps of the present invention is manifestly capable of achieving the above enumerated objects and while the preferred embodiments of the present invention have been disclosed, it will be appreciated that the present invention is not limited thereto but may be otherwise embodied within the scope of the following claims.

What is claimed is:

1. A desiccant end cap for mounting on a member having a face portion and an outer portion extending transversely thereto comprising a cup-like member having an end portion, a rim extending from said end portion for overlying said outer portion of said member, desiccant container means mounted on said end portion, and spacer means for providing an effective clearance space between substantially said entire end portion and said face portion to permit effective communication between said desiccant container means and substantially said entire face portion.

2. A desiccant end cap as set forth in claim 1 including securing means on said rim for securing said end cap to said member.

3. A desiccant end cap as set forth in claim 1 wherein said rim includes an outwardly flared end portion for guiding said rim onto said outer portion of said member.

4. A desiccant end cap as set forth in claim 3 including securing means on said rim for securing said end cap to said member.

5. A desiccant end cap as set forth in claim 4 wherein said securing means comprise spaced dimples extending inwardly from said rim.

6. A desiccant end cap as set forth in claim 1 wherein said end portion merges into said desiccant container means which comprises a cup portion which is formed integrally with said end portion, and panel means secured across said end portion as a cover for said cup portion.

7. A desiccant end cap as set forth in claim 6 wherein said panel means extends substantially entirely across said end portion and causes said end portion to be relatively impermeable.

8. A desiccant end cap as set forth in claim 1 wherein said desiccant container means comprises cup means on said end portion, desiccant means in said cup means, aperture means in said cup means for increasing the permeability of said cup means, and porous retentive barrier means covering said aperture means for preventing said desiccant means from passing through said aperture means.

9. A desiccant end cap for mounting on a member having a face portion and an outer portion extending transversely thereto comprising a cup-like member having an end portion, a rim extending from said end portion for overlying said outer portion of said member, desiccant container means mounted on said end portion, and spacer means for providing a clearance space between said end portion and said face portion to permit communication between said desiccant container means and said face portion, said spacer means comprising spaced dimples extending inwardly from said end portion toward said face portion.

10. A desiccant end cap as set forth in claim 9 wherein said desiccant container means comprises cup means mounted on said end portion.

11. A desiccant end cap as set forth in claim 10 wherein said end portion is substantially planar.

12. A desiccant end cap for mounting on a member having a face portion and an outer portion extending transversely thereto comprising a cup-like member having an end portion, a rim extending from said end portion for overlying said outer portion of said member, desiccant container means mounted on said end portion, spacer means for providing a clearance space between said end portion and said face portion to permit communication between said desiccant container means and said face portion, securing means on said rim for securing said end cap to said member, said securing means comprising first spaced dimples extending inwardly from said rim, and said spacer means comprising second spaced dimples extending inwardly from said end portion toward said face portion.

13. A desiccant end cap as set forth in claim 12 wherein said desiccant container means comprises cup means mounted on said end portion.

14. A desiccant end cap for mounting on a member having a face portion and an outer portion extending transversely thereto comprising a cup-like member having an end portion, a rim extending from said end portion for overlying said outer portion of said member, desiccant container means mounted on said end portion, and spacer means for providing a clearance space between said end portion and said face portion to permit communication between said desiccant container means and said face portion, said rim being permeable and of a size to engage said outer portion of said member, whereby the effect of said desiccant is communicated to said outer portion through said clearance space and through said permeable rim.

15. A desiccant end cap as set forth in claim 14 wherein said rim is of a size to engage said outer portion with an interference fit.

* * * * *

40

45

50

55

60

65