

(19)
(12)

(KR)
(A)

(51) 。 Int. Cl.7
H01F 41/00

(11)
(43)

10-2004-0028829
2004 04 03

(21) 10-2004-0003885
(22) 2004 01 19

(71) 186-9

(72) 186-9

201 204

(74)

:

(54)

가 , PCB

1 2 가 ; ,

가 ; 가

2 가 ; 가 1

가 J ;

J , 1 2 2 가 ;

2 ;

가 가 ; .

2

, J ,

- 1
- 2
- 3
- 4
- 5
- 6
- 7

PCB

- 1,2 : 3,4 :
- 5,5a : 6,7 : (1 , 2)
- 6a,7a: 6b,7b :
- 8,9 : 10 :
- 11,12 : 13 :
- 14 : 15 :
- 16 : 17 : PCB
- 18 : 19 :
- 20 :

(30) 6 (31)(32) PCB 2 (34) 1 (31)(32) 가 (35) 2 (33) , (36)

1 (35) 가 2 (36)

(33) 가 (31)(32) (35)(36) , 1,2 (35)(36) (35)(36) (35a)(36a)

7

5)(36) (33) (37)(38) (31)(32) U (35)(36) (1), (3 (2).

(35)(36) (35a)(36a) (3).

가 가 가 (39) (4).

4) (40) (30) PCB (7). PCB (3

(31)(32) (30) 4가 (35)(36) (33) 가 (35a)(36a) (35a)(35b)(36a)(36b) 가

가 (4) (30) (35a)(35b)(36a)(36b) PCB (34) (35)(36) 가

PCB 가 ,

1 2 가

가 ;

가

2 가 ;

1

가 J ;

J 1 2 2 가

2 ;

가 가 ;

가 2 가

PCB

1 , 2

(1)(2) (3)(4) (1).

(3)(4) 1 2 2 3 (6)(7) (8)(9) 5 8 9
(3)(4) (8)(9)
(4) (9)

(3)(4) (2). (L) (19) (3)(4) (20)가 (3)(4)
L

(6a)(6b)(7a)(7b) (裸線) 가

(L) (3)(4) (L)가 (6a,7a)(6b,7b) (3)(4)
(5)(5a) 1 2 (L₁: (6)(7) (L₂: : L₁ + L₂ + L₃) (3

).

(6)(7) 6a 7a가 (8)(9) J (6b 7b) (4).

J (6a)(6b)(7a)(7b) (6)(7) 4 (A,B), (10) (6)(7)
(6a)(7a) (10) (11)(12) (5).

(6a)(7a) (6b)(7b)

6). 2 (6a)(7a) 2가 (6a)(7a) (6b)(7b) 2가
(6a)(7a) (6a)(7a)

가 (6a)(6b)(7a)(7b) () 가 (13)
(7).

(6a)(6b)(7a)(7b) (14) (8), PCB
(6a,6b,7a,7b) (15)

(9)

(16)

(3)(4)가

L₁ L₂

J

a)(7a)(6b)(7b)

(16)
(18)

5

PCB

(17)

(6

1 2 가J ()

가
2
가

가 , PCB

PCB

가

가

(57)

1.

1

2

가

;

가

가

;

가

가

1

2

;

가

J

;

J

1

2

2

가

;

2

;

가

가

;

2.

1

3.

2

4.

1 3

1 2

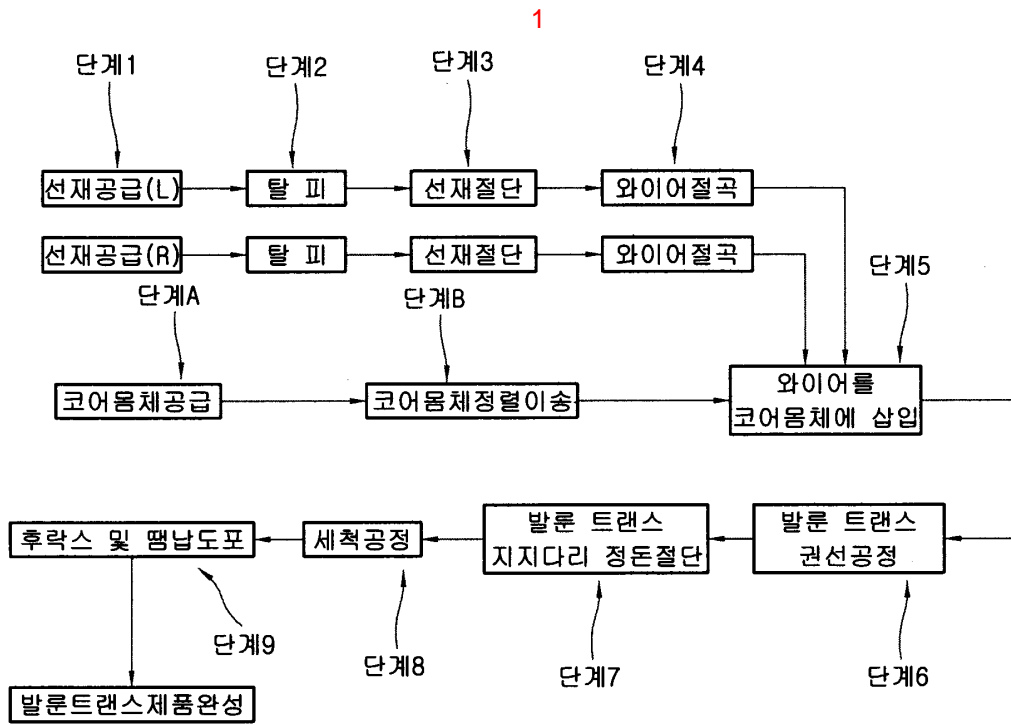

2

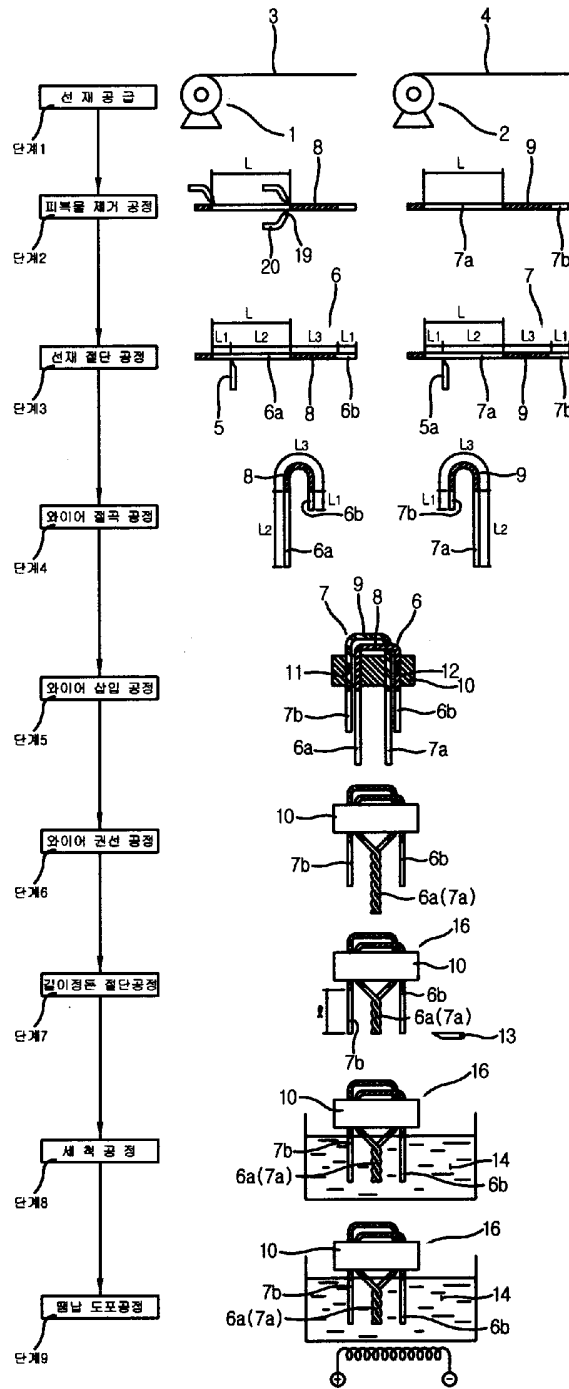

3

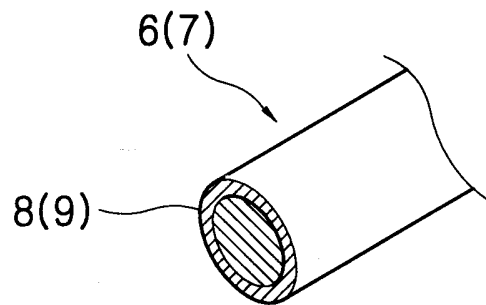

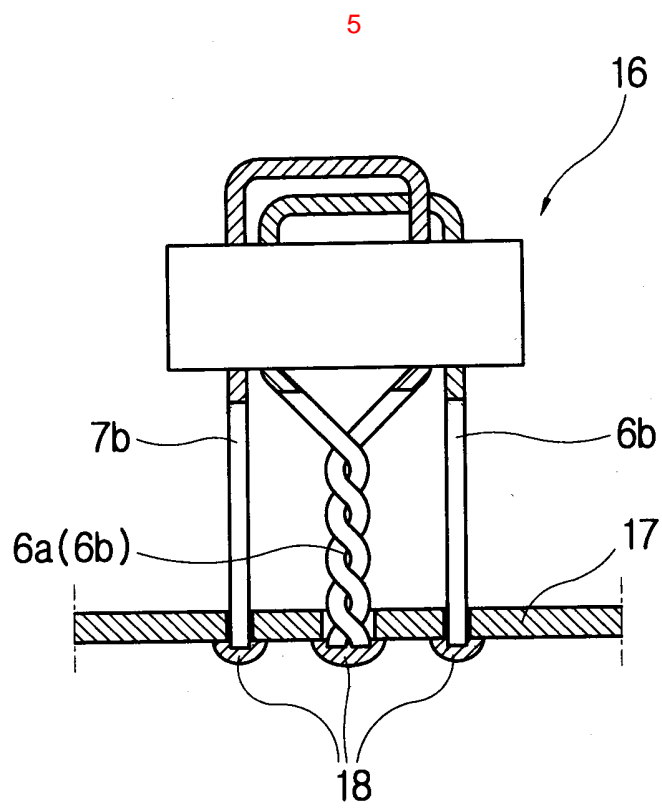
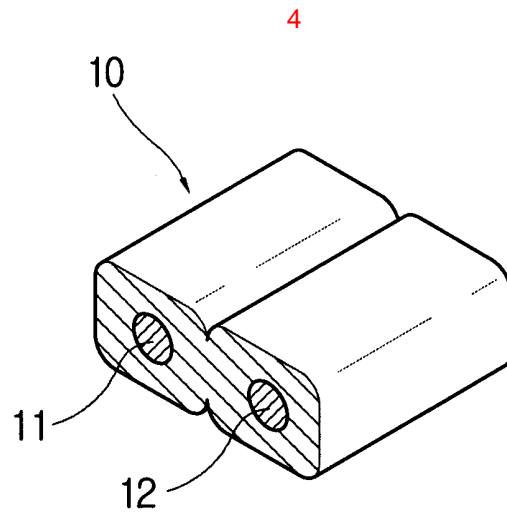

6

