



US 20020116901A1

(19) **United States**

(12) **Patent Application Publication**

Weder

(10) **Pub. No.: US 2002/0116901 A1**

(43) **Pub. Date: Aug. 29, 2002**

(54) **FLOWER BLOOM PROTECTIVE DEVICE**

Publication Classification

(76) Inventor: **Donald E. Weder**, Highland, IL (US)

(51) **Int. Cl.⁷ B65B 61/00**

(52) **U.S. Cl. 53/410**

Correspondence Address:

DUNLAP, CODDING & ROGERS P.C.

PO BOX 16370

OKLAHOMA CITY, OK 73114 (US)

(57)

ABSTRACT

(21) Appl. No.: **10/043,600**

(22) Filed: **Jan. 10, 2002**

Related U.S. Application Data

(63) Continuation of application No. 09/796,938, filed on Feb. 28, 2001, now abandoned.

A bloom support device for protecting a cut flower during shipping, the bloom support device having a concave body providing a substantially closed proximal end clearlyly disposed about a stem of the flower and a substantially open distal end compressingly folding a bloom of the flower into a folded arrangement and retaining the folded arrangement in a secure shipping arrangement. The concave body has a stress intensification feature for tearing the bloom support device off of the bloom.

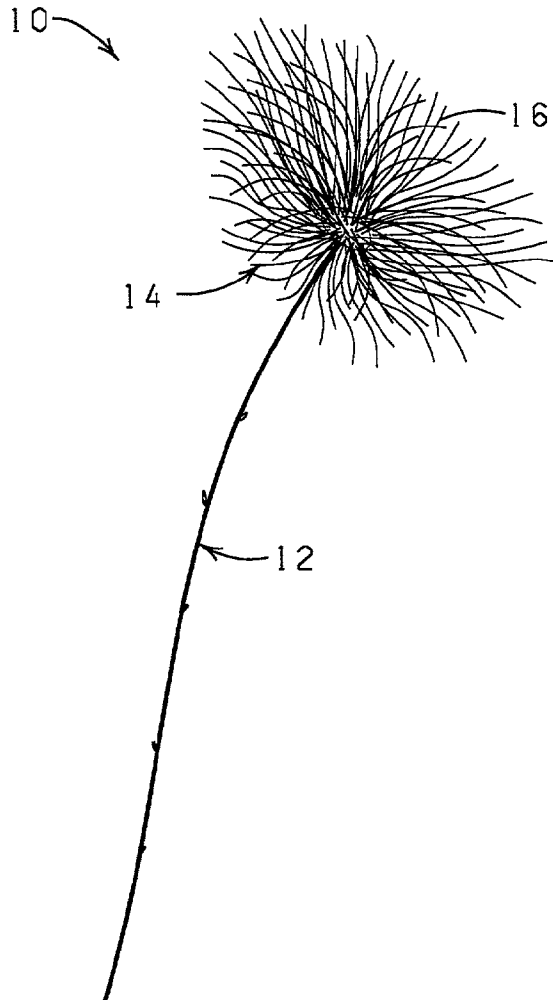

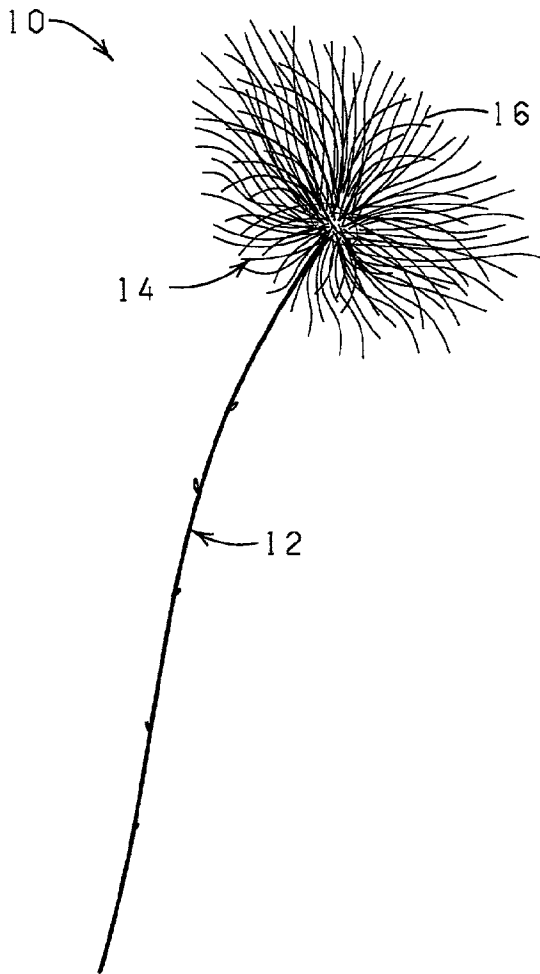

FIG. 1

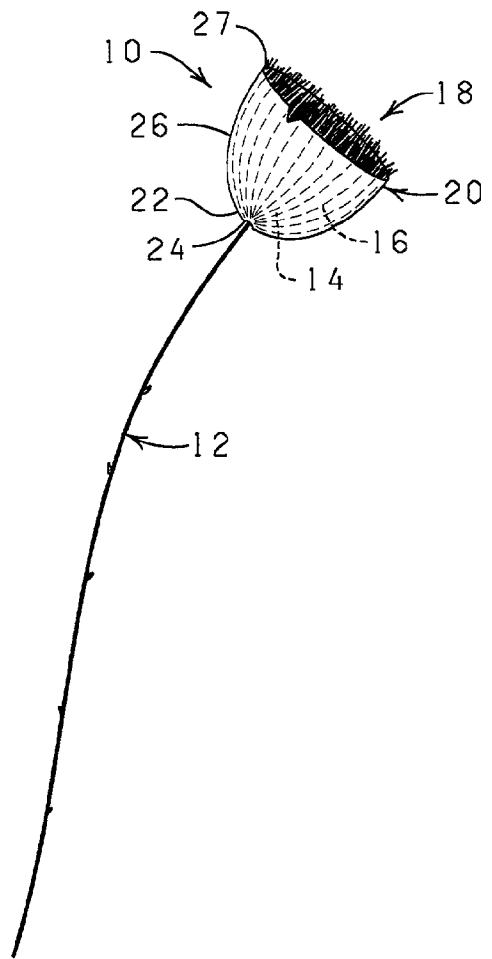

FIG. 2

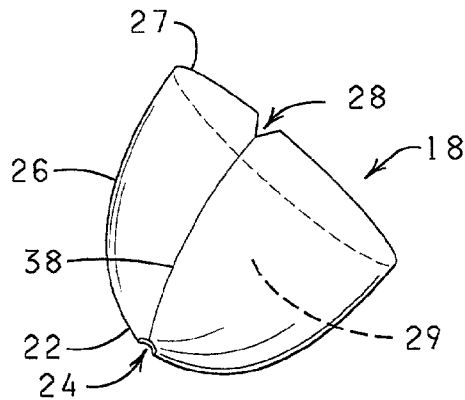
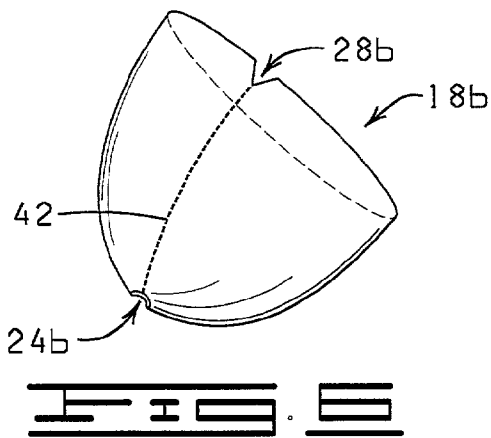
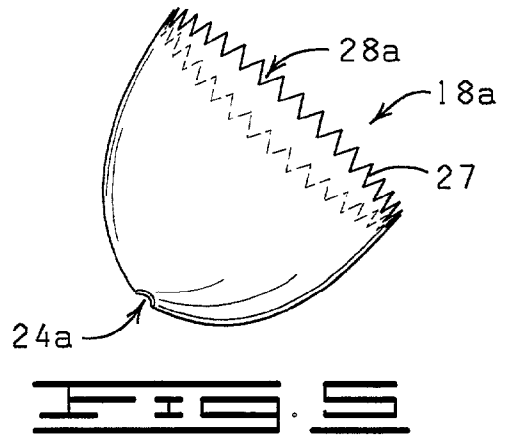
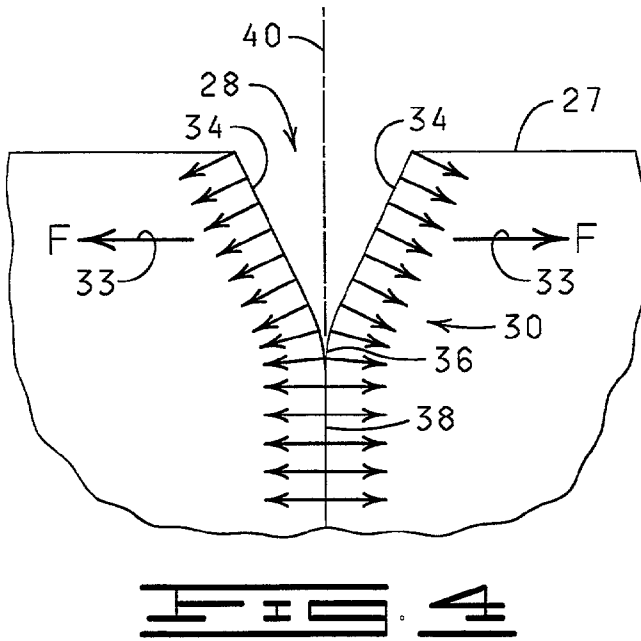

FIG. 3



FLOWER BLOOM PROTECTIVE DEVICE

FIELD OF THE INVENTION

[0001] The present invention relates generally to the field of shipping and storage devices for blooming flowers, and more particularly, but not by way of limitation, to a device for protecting a flower bloom during shipping and storage.

SUMMARY OF THE INVENTION

[0002] The present invention provides a bloom support device for protecting the bloom of a cut flower during shipment and storage. The bloom support device has a concave body, substantially closed at a proximal end and forming an open distal end for receiving engagement of the bloom. An aperture is provided at the proximal end through which a stem portion of the flower is disposed as the concave body is moved along the stem toward the bloom in operatively placing the bloom support device about the bloom. In the operative position the concave body encapsulates the bloom, providing a compressive support to the bloom's delicate petals which are urged into a folded arrangement. A stress-intensification member is provided in the concave body to facilitate a tearing away of the bloom support device from the bloom in such a manner that in response to an applied tearing force, the stress-intensification member imparts a tearing of the concave body along a tear line extending between the distal end of the concave body with the aperture of the proximal end of the concave body. The stress intensification member can be a notch formed in the concave body extending a distance from the distal end and having an apex directed toward the aperture in the proximal end. A plurality of notches so arranged can be provided at the distal end of the concave body to facilitate the presentation of a notch to an operator. The stress-intensification member can also be a plurality of perforations defining such a tear-line.

[0003] The stress intensification member permits an effective tearing action from a vantage point most likely to be used by an employee who is unpackaging a batch of flowers. Namely, it is most likely that one unpackaging the flowers will tear the bloom support device from the outermost extremity, that is, from the more accessible distal end, because the operator is typically motivated to unpackage the flowers quickly. The stress intensification member provides the ability to tear away the bloom support device so as to unpackage the flowers in a minimal amount of time while preventing damage to the flower bloom and stem. These and other advantages and features of the present invention will be apparent from the following description when read in conjunction with the drawings and appended claims.

BRIEF DESCRIPTION OF THE DRAWINGS

[0004] FIG. 1 is a pictorial representation of a flower well-suited to receive a bloom support device of the present invention for protection during shipment and storage.

[0005] FIG. 2 is a pictorial representation of a cut flower of FIG. 1 having a bloom support device constructed in accordance with the present invention disposed about a bloom portion of the cut flower.

[0006] FIG. 3 is a pictorial representation of a bloom support device constructed in accordance with the present invention.

[0007] FIG. 4 is a diagrammatical illustration of a stress distribution imparted to the stress intensification member of the bloom support device of FIG. 3.

[0008] FIG. 5 is a pictorial representation of a bloom support device constructed in accordance with the present invention having a plurality of stress intensification members.

[0009] FIG. 6 is a pictorial representation of a bloom support device constructed in accordance with the present invention having a plurality of longitudinal perforations.

DETAILED DESCRIPTION

[0010] Referring to the drawings in general, and more particularly to FIG. 1, shown therein is a cut flower 10 having a stem portion 12 and a bloom portion 14. The bloom portion 14 is illustrated as having a plurality of petals 16 which are susceptible to damage during shipping.

[0011] Referring now to FIGS. 2 and 3, to prevent damage to the bloom portion 14 of the cut flower 10 during shipping, the petals 16 of the bloom portion 14 are folded toward each other, that is, in an arrangement of the petals 16 like a budded arrangement and a bloom support device 18 is positioned about the folded petals 16. The bloom support device 18 is provided with a concave body having a proximal end 22 with an aperture 24 through which the stem portion 12 (See FIG. 2) passes to allow the proximal end 22 to abut the bloom portion 14. An upwardly-extending, concave body 26 extends from the proximal end 22 and terminates in an open-ended distal end 27, the concave body 26 in this manner encapsulating the petals 16 in the folded arrangement. Thus, the concave body 26 is clearly disposed about the stem portion 12 and supportingly disposed about the bloom portion 14.

[0012] The concave body 26 in this manner provides a cavity 29 for receiving engagement of the bloom portion 14. The open distal end 27 communicates with the cavity 29 for passage of the bloom portion 14 into the cavity 29. The aperture 24 in the proximal end permits passage of the stem portion 12 as the bloom portion 14 passes into the cavity 29.

[0013] It should be understood that removal of the bloom support device 18 from the bloom portion 14 can be achieved without damage to the stem portion 12 or the bloom portion 14, as described hereinbelow.

[0014] The concave body 26 can be provided by any of a number of conventional manufacturing methods. The bloom support device 18 can be made of a polymeric material and cut into a flat pattern, then thermoformed to provide the concave shape. Alternatively, the bloom support device 18 made of a polymeric material may be cut from a stack of two sheets that are appropriately seamed together. The bloom support device 18 may also be made of paper, foil, laminations and combinations thereof.

[0015] To enhance removal of the bloom support device 18 from the cut flowers, the open distal end 27 of the concave body 26 is provided with a notch 28. The notch 28 provides a stress intensification member facilitating a tearing action. The tearing action may be directed along a tear line, as defined by another stress intensification member along the concave body 26 such as a crease 38 shown in FIG. 3. In this manner, an operator removing the bloom support device 20

grasps it on opposing sides of the notch 28 and pulls the concave body 26 apart. FIG. 4 diagrammatically illustrates the resultant stress field 30 that acts on the distal end 27 as a tearing force "F" is applied in opposite directions across the notch 28, the force denoted by arrows 32, 33. The stress vectors act orthogonally to the sloping edges 34 of the notch 28, the apex 36 of which creates a stress intensification member to decrease the magnitude of the force "F" necessary to shear the material to propagate a tear. Once the tear forms, it will be noted the stress field acts on the material in a substantially parallel direction to that of the applied force "F," such that an even lesser magnitude of force "F" is necessary to continue the tearing action once the tear is initially propagated. A relatively sharp notch 28, having steeply sloped edges 34, provides a relatively large stress intensification member. By providing a sharp notch 28, the resulting force "F" necessary to initiate a tear can be provided as substantially the same force "F" that is required to continue the tear once initiated.

[0016] It will be noted that in tearing the concave body 26 of the bloom support device 18 along the tear line that extends between the notch 28 with the aperture 24, the notch 28 is formed with the apex 36 at a desired axial plane 40 that includes the axial center line of the concave body 26. The edges 34 of the notch 28 are substantially equilaterally disposed about the axial plane 40. By selecting an appropriate material for the bloom support device 18, the tear propagates in a tear line along the axial plane 40 and thereby separates the bloom support device 20 from the flower 10 by tearing along a line extending between the notch 28 and aperture 24 without the aid of a stress intensification member along the concave body 26, such as the crease 38 in FIG. 3.

[0017] FIG. 5 shows a bloom support device 18a wherein the distal end 27a has a plurality of notches 28a, at least one of which can be selected for use in initiating the tearing action as discussed above. Although shown as a plurality of notches, only one of the notches is designated by the reference numeral 28a. By providing a number of notches 28a it is contemplated that the operator will use the one most accessible and therefore not need to reposition the flower to access one of the notches 28a. This is beneficial where a number of flowers 10 are typically bulk packaged closely together, wherein providing a number of notches 28a makes it more likely the operator will initiate the tearing action at a notch 28a as desired.

[0018] FIG. 6 shows yet another bloom support device 18b wherein a plurality of perforations 42 is provided between the notch 28b and the aperture 24b. Like the crease 38 of the concave body 26 of FIG. 3, the plurality of perforations 42 provides a stress intensification member defining the tear line extending between the notch 28b and the aperture 24b independent of the material characteristics associated with the direction of the tear line. Other stress intensifications will work as well, such as a seam. It will be noted that a longitudinal stress intensification member along the concave body 26 may be used in conjunction with one notch 28b as in FIG. 6, as well as a plurality of stress intensification members each used with a corresponding notch 28a as in FIG. 5.

[0019] The foregoing description thus provides a method for packaging one or more flowers, and hence a batch of

flowers in like manner, at a shipping location and subsequently unpackaging the flowers at a destination location. The bloom support device 18 is placed onto the bloom portion 14 to urge a folded arrangement of the petals 16 to prevent damage. The flower is then shipped to the destination in the folded arrangement. At the destination the bloom supports 18 are removed quickly and easily by tearing the bloom support device as facilitated by a stress intensification member, that is, at an accessible notch or perforation.

[0020] It is to be understood that even though numerous characteristics and advantages of various embodiments of the present invention have been set forth in the foregoing description, together with details of the structure and function of various embodiments of the invention, and changes may be made in details especially in matters of structure and arrangement of parts within the principles of the present invention to the full extent indicated by the broad general meaning of the terms in which the appended claims are expressed.

What is claimed is:

1. A bloom support device for protecting a flower during shipment, the flower having a stem and a bloom, the bloom support device comprising:

a concave body defining a cavity, the concave body having a substantially closed proximal end and a substantially open distal end, the closed proximal end having an aperture adapted to provide an opening to receive the stem of the flower which passes therethrough as the substantially open end is moved to a position adjacent the bloom, the cavity adaptable for a receiving engagement of the bloom wherein the concave body urges the bloom into a folded arrangement and compressingly retains the folded arrangement; and

a stress intensification member supported by the concave body for tearing the bloom support device along a tear line in the concave body from the distal end to the aperture in order to remove the bloom support device from the flower.

2. The bloom support device of claim 1 wherein the stress intensification member comprises an edge in the distal end forming a notch.

3. The bloom support device of claim 2 wherein the notch forms a substantially triangular aperture in the distal end with an apex directed toward the proximal end of the concave body, the apex positioned on a desired axial plane between the proximal and distal ends and the notch formed of a pair of opposing angular edges that extend from the apex toward the distal end substantially equilaterally relative to the axial plane.

4. The bloom support device of claim 1 wherein the stress intensification member comprises an edge in the distal end forming a plurality of notches.

5. The bloom support device of claim 4 wherein each notch forms a substantially triangular aperture in the distal end with an apex directed toward the proximal end of the concave body, each apex positioned on a desired axial plane between the proximal and distal ends and each notch formed of a pair of opposing angular edges that extend from the apex toward the distal end substantially equilaterally relative to the respective axial plane.

6. The bloom support device of claim 1 wherein the stress intensification member comprises a plurality of longitudi-

nally extended perforations in the concave body connecting the distal end and the aperture in the proximal end of the concave body.

7. The bloom support device of claim 6 in combination with a notch in the distal end formed of angled edges connected at an apex that is contiguous with the perforations.

8. The bloom support device of claim 3 wherein the notch provides a stress intensification characteristic in the concave body in response to a pulling force applied in substantially opposite directions across the notch, the stress intensification characteristic reducing the pulling force necessary to initiate a tear in the concave body at the apex of the notch.

9. The bloom support device of claim 8 wherein the stress intensification characteristic provides for a pulling force necessary to initiate a tear in the concave body that is substantially the same as a pulling force necessary to continue the tear after the tear has been initiated.

10. The bloom support device of claim 1 wherein the concave body is formed of a polymeric material that is thermoformed to provide the concave characteristic.

11. The bloom support device of claim 1 wherein the concave body is formed of a pair of polymeric sheets that are seamed together to provide the concave characteristic.

12. The bloom support device of claim 3 wherein a selected pulling force applied substantially in opposite directions across the notch initiates a tear in the concave body that propagates from the apex of the notch to the aperture in the proximal end.

13. A method for packaging a floral grouping at a shipping location to protect from shipping damage, the flower having a stem portion and a bloom portion, the method comprising the steps of:

- (a) providing a floral grouping containing at least one flower having a bloom portion and a stem portion;
- (b) providing a bloom support device with a concave body defining a cavity, the concave body having a substantially closed end with an aperture for passing of the

stem portion and an open distal end, the concave body having a selected stress intensification member;

(c) disposing the stem through the hole and moving the bloom support device toward the bloom portion;

(d) placing the concave body about the bloom portion to urge the bloom portion into a folded arrangement; and

(e) transporting the flower in the folded arrangement and the bloom support device to the destination location.

14. The method for packaging of claim 13 further comprising the step of unpackaging the bloom support device at the destination location by initiating a tear in the bloom support device from the stress intensification member on the bloom support.

15. A packaged and subsequently unpackaged flower in accordance with the method of claim 14 wherein the bloom support device is torn from a distal end adjacent the bloom toward a proximal end adjacent the stem portion.

16. The packaged and subsequently unpackaged flower of claim 15 wherein in the step of providing the bloom support, the stress intensification member comprises a notch formed in the distal end of the bloom support.

17. The packaged and subsequently unpackaged flower of claim 15 wherein in the step of providing the bloom support, the stress intensification member comprises a plurality of perforations connecting the distal end and the proximal end.

18. The packaged and subsequently unpackaged flower of claim 16 wherein in the step of providing the bloom support, the stress intensification member further comprises a plurality of perforations connecting the notch and the proximal end.

19. The packaged and subsequently unpackaged flower of claim 15 wherein in the step of providing the bloom support, the stress intensification member is selected from a group consisting of a notch, crease, seam, plurality of perforations, and combination thereof.

* * * * *