



US 20020036220A1

(19) **United States**

(12) **Patent Application Publication**
Gabbay

(10) **Pub. No.: US 2002/0036220 A1**

(43) **Pub. Date: Mar. 28, 2002**

(54) **CURVED IMPLANTABLE SHEATH AND METHOD OF MAKING SAME**

Related U.S. Application Data

(76) Inventor: **Shlomo Gabbay**, Short Hills, NJ (US)

(63) Continuation-in-part of application No. 09/669,821, filed on Sep. 26, 2000.

Publication Classification

Correspondence Address:

Gary J. Pitzer
Amin & Turocy, LLP
National City Center
1900 E. 9th Street, 24th Floor
Cleveland, OH 44114 (US)

(51) **Int. Cl.⁷** **A45F 5/00; B65D 1/00**

(52) **U.S. Cl.** **224/191**

(57) **ABSTRACT**

The present invention provides a method for making a curved implantable sheath. A sheet of flexible material is urged into engagement with a member having a curved surface having a desired configuration. The sheet and member are placed in a fixation solution so that the sheet assumes the configuration of the surface engaged thereby.

(21) Appl. No.: **09/861,915**

(22) Filed: **May 21, 2001**

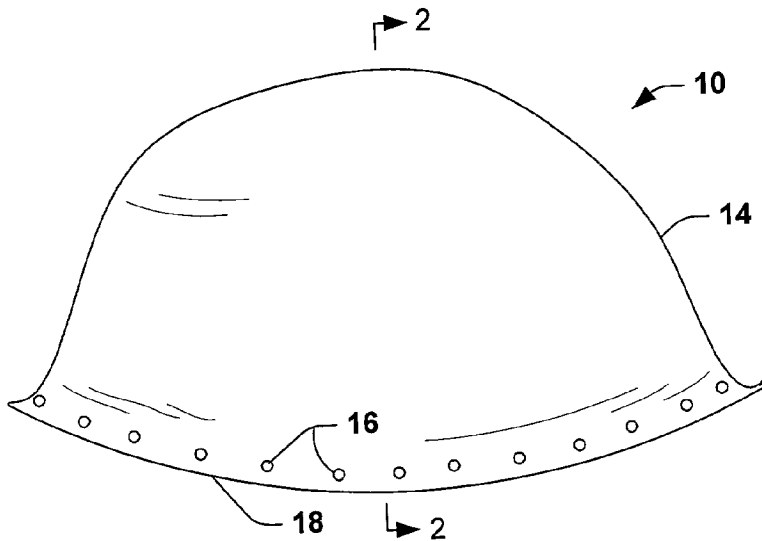

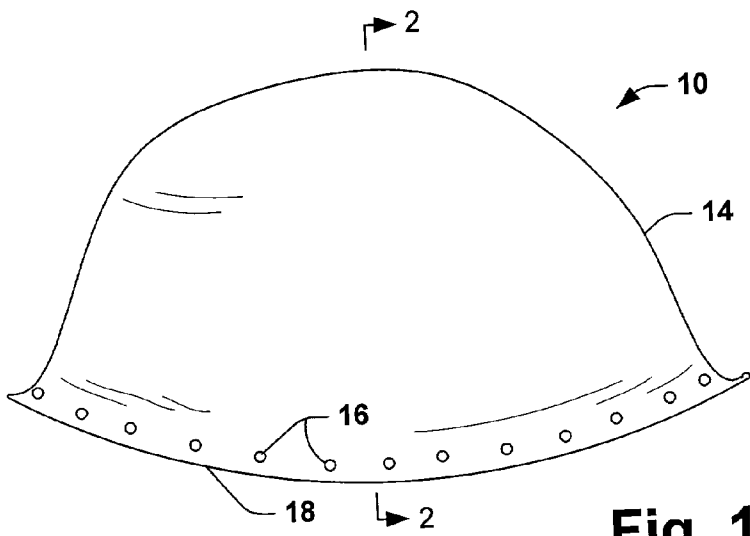

Fig. 1

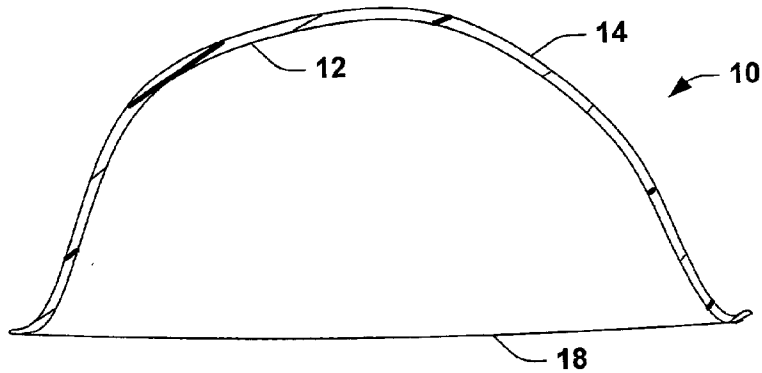

Fig. 2

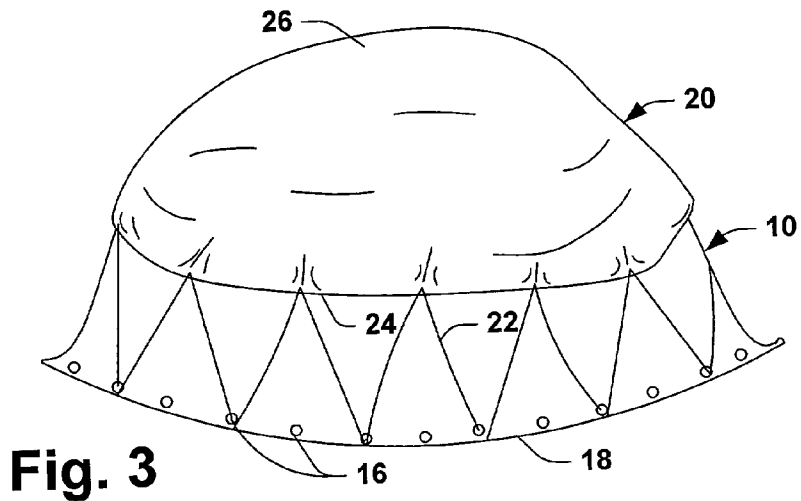

Fig. 3

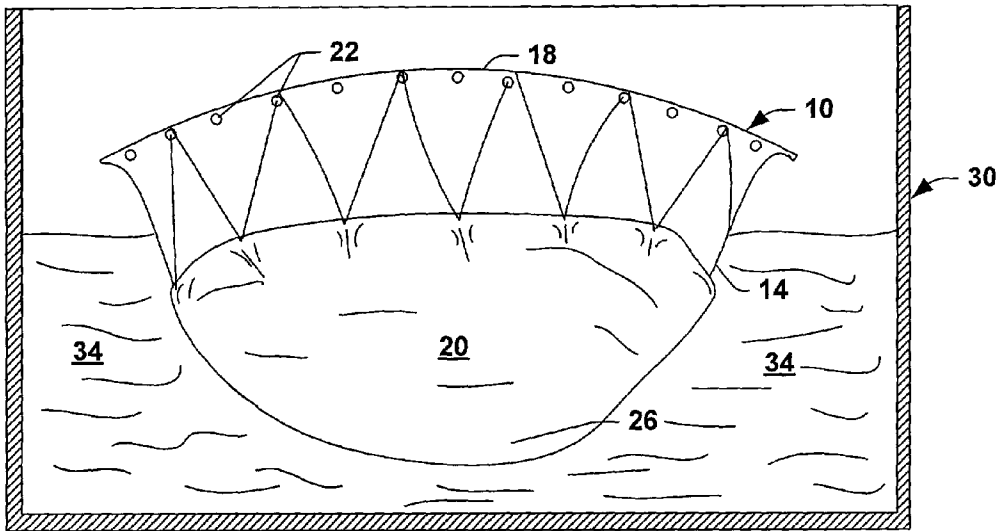

Fig. 4



Fig. 5

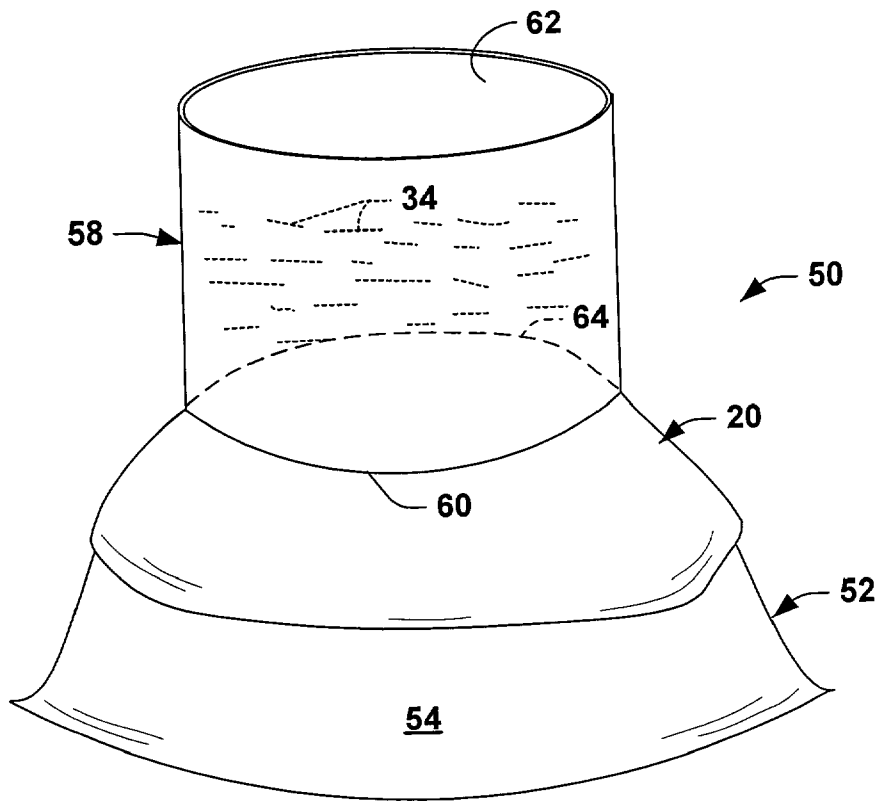

Fig. 6

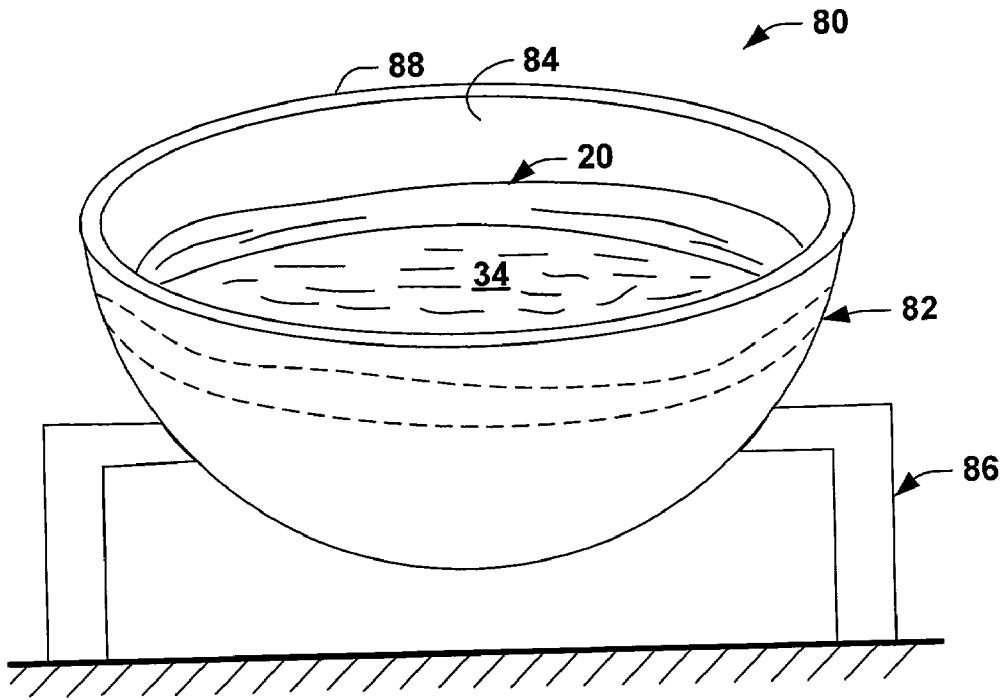

Fig. 7

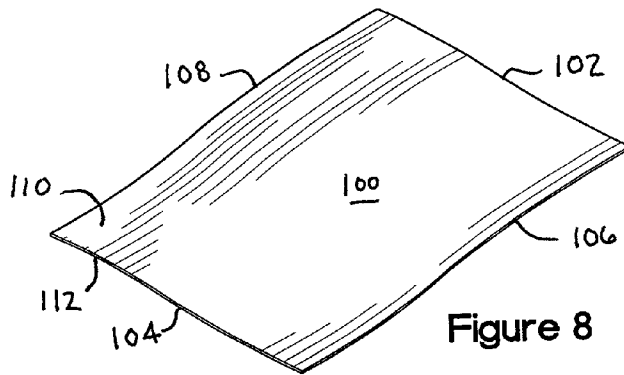

Figure 8

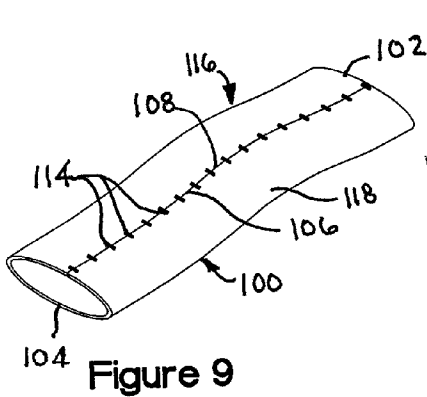

Figure 9

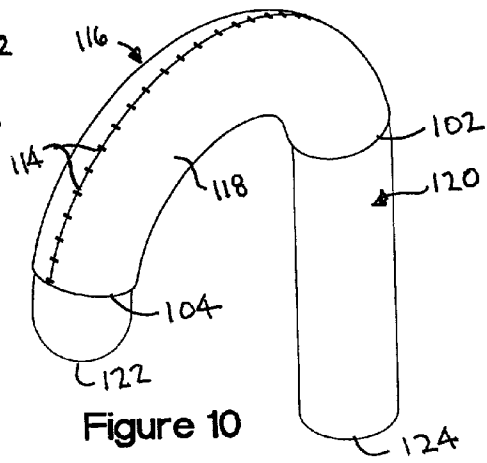

Figure 10

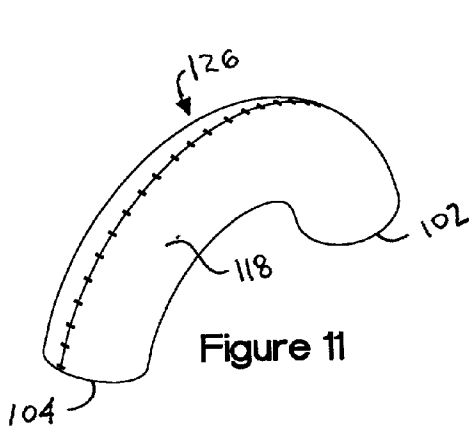

Figure 11

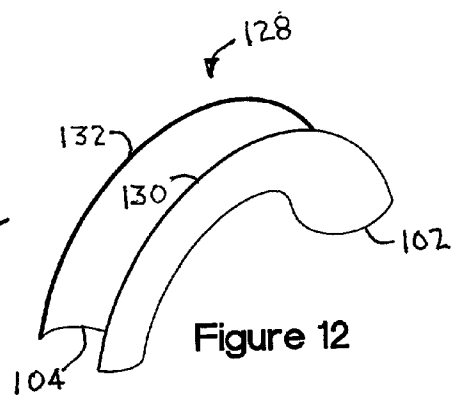

Figure 12

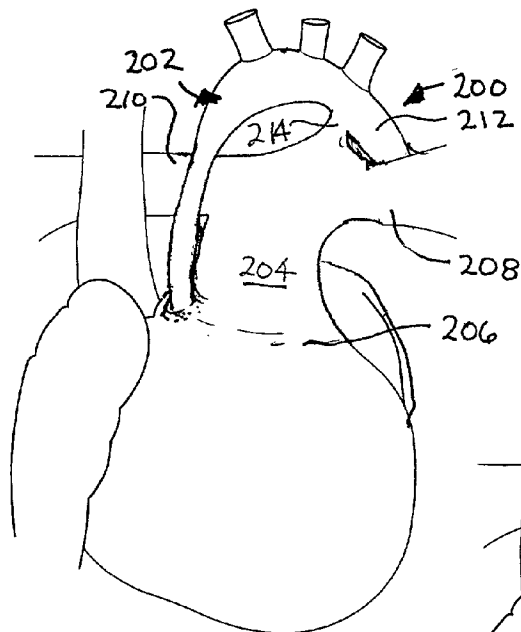

Figure 13

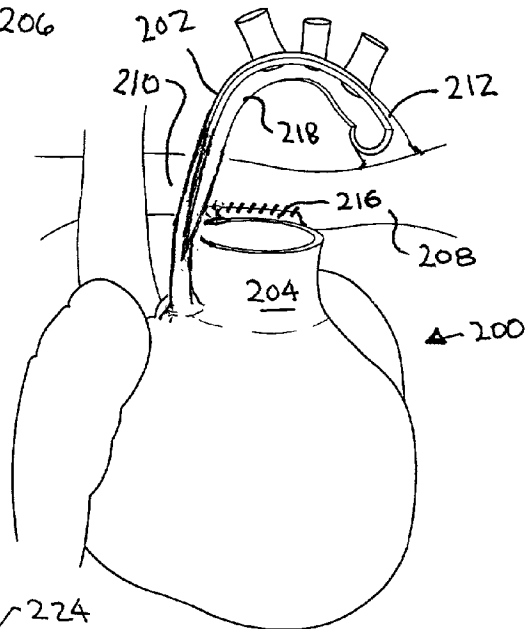

Figure 14

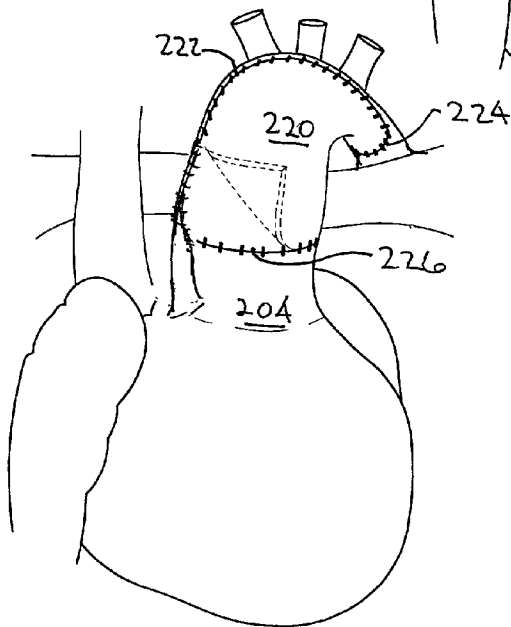

Figure 15

CURVED IMPLANTABLE SHEATH AND METHOD OF MAKING SAME

RELATED APPLICATION

[0001] This application is a continuation-in-part of U.S. patent application Ser. No. 09/669,821, which was filed on Sep. 26, 2000, and entitled SYSTEM AND METHOD FOR MAKING A CALOTTE-SHAPED IMPLANTABLE SHEATH.

TECHNICAL FIELD

[0002] The present invention relates to implantable tissue and, more particularly to a curved implantable sheath and to a method for making a curved sheath.

BACKGROUND

[0003] Various configurations of implantable structures are employed to help repair diseased and malformed organs and other tissue. By way of example, congenital cardiac malformations as well as other diseased conditions, require treatment, which can include drug therapy and/or surgery. Often times, it is necessary to replace or reconstruct an artery or other major vessel, such as the aorta or pulmonary artery.

[0004] In one particular condition, known as hypoplastic left heart syndrome, severe aortic valve hypoplasia and/or aortic valve atresia develop. As a result of such conditions, the aorta may significantly underdevelop, providing a rudimentary ascending aorta having a diameter of about one to about four millimeters. Also as a consequence of limited outflow from the heart, the left ventricle develops abnormally and may be virtually absent.

[0005] Because certain curved shapes are difficult to reproduce, a generally flat sheath of biocompatible tissue typically is used for many types of procedures. In other cases a homograft, such as from a cadaver is used.

SUMMARY

[0006] The following presents a simplified summary of the invention in order to provide a basic understanding of some aspects of the invention. This summary is not an extensive overview of the invention. It is intended to neither identify key or critical elements of the invention nor delineate the scope of the invention. Its sole purpose is to present some concepts of the invention in a simplified form as a prelude to the more detailed description that is presented later.

[0007] One aspect of the present invention provides a method for making a curved implantable sheath. A sheet of flexible material is urged into engagement with a member having a curved surface of a desired configuration. The sheet and member are placed in a fixation solution so that the sheet assumes the configuration of the surface engaged thereby.

[0008] Another aspect of the present invention provides a method for making a sheath having a curved contour. The method includes mounting a sheet of a biological tissue material to an elongated member having a curved exterior portion. The sheet and elongated member are placed in a fixation solution so that at least part of the sheet is fixed to a configuration corresponding to the exterior portion of the elongated member. The sheet is separated from the elon-

gated member to provide an elongated sheath of substantially biocompatible material having a desired curved contour.

[0009] According to another aspect of the present invention, the sheet can be formed to have a generally C-shaped cross section.

BRIEF DESCRIPTION OF THE DRAWINGS

[0010] To the accomplishment of the foregoing and related ends, certain illustrative aspects of the invention are described herein in connection with the following description and the annexed drawings. These aspects are indicative, however, of but a few of the various ways in which the principles of the invention may be employed and the present invention is intended to include all such aspects and their equivalents. Other advantages and novel features of the invention will become apparent from the following detailed description of the invention when considered in conjunction with the drawings, in which:

[0011] FIG. 1 is an example of a base member having a surface over which tissue may be fixed in accordance with the present invention;

[0012] FIG. 2 is a cross-sectional view of the base member of FIG. 1 taken along line 2-2;

[0013] FIG. 3 is an example of tissue held against the surface of a base member in accordance with the present invention;

[0014] FIG. 4 is an example of tissue being fixed to a desired shape in accordance with the present invention;

[0015] FIG. 5 is an example of a calotte-shaped sheath produced from tissue treated in accordance with the present invention;

[0016] FIG. 6 is another example of tissue being fixed to a desired shape in accordance with the present invention;

[0017] FIG. 7 is yet another example of tissue being fixed to a desired shape in accordance with the present invention;

[0018] FIG. 8 is a generally flat sheet of flexible material;

[0019] FIG. 9 is an example of a generally tubular structure that can be formed from the sheet of FIG. 8;

[0020] FIG. 10 is the tubular structure of FIG. 9 mounted over a curved member in accordance with the present invention;

[0021] FIG. 11 is an example of a curved tubular sheath that can be produced in accordance with an aspect of the present invention;

[0022] FIG. 12 is an example of a curved sheath of tissue in accordance with an aspect of the present invention;

[0023] FIG. 13 is an example of heart having a congenital defect;

[0024] FIG. 14 is the heart of FIG. 13 after part of associated vessels have been removed; and

[0025] FIG. 15 is an example of a heart in which a curved sheath of tissue has been applied in accordance with the present invention.

DESCRIPTION OF THE INVENTION

[0026] Various illustrative aspects of the present invention will now be described in connection with the following figures.

[0027] The present invention provides a system and method that may be used to fix tissue to a desired shape so as to better conform to contoured organs and tissue against which the tissue is to engage when implanted. While the following examples will be described with respect to forming a calotte-shaped sheath of tissue, those skilled in the art will understand and appreciate that other shapes, such as cylindrical sheaths and curved arches, also may be formed in accordance with the present invention.

[0028] Turning now to FIGS. 1 and 2, a generally semi-spherical base 10 is illustrated. The base 10, which may be a bowl formed of a rigid material (e.g., a metal or plastic material), has an inner surface 12 and an outer surface 14. In this example, the inner surface 12 is curved in a convex manner and the outer surface 14 is curved in a generally concave manner.

[0029] In accordance with an aspect of the present invention, the inner and/or outer surfaces 12 and 14, respectively, may be dimensioned and configured to correspond to the shape of a selected part of a human brain. It is to be appreciated that other shapes and sizes may be utilized to process tissue to have a desired contour, such as for implantation in other types of surgical procedures. In addition, the inner surface 12 may be dimensioned to have radius of curvature that is less than the outer surface 14. The inner and outer surfaces 12 and 14 also may have different shapes or contours. As a result, differently dimensioned and/or shaped sheaths may be formed with the same base 10.

[0030] In this example, the base 10 also has a plurality of apertures 16 located near an open end 18 of the base. The apertures 16 provide a convenient way to secure a sheet of tissue 20 to the outer surface 14 of the base 10, such as shown in FIG. 3. The sheet of tissue 20 may be substantially any type of biological tissue. By way of example, the tissue may be animal pericardium (e.g., equine, bovine, porcine, etc.), collagen, animal dura mater, or other type of suitable sheet of tissue. To provide better results, the sheet of tissue should be a generally fresh, soft sheet of tissue. The sheet of tissue 20 may be in nearly any shape, such as rectangular, circular, elliptical, etc.

[0031] By way of illustration, one or more sutures 22 are sewn through a perimeter edge 24 of the tissue 20 so as to hold at least a substantial portion of the tissue in engagement with the outer surface 14 of the base 10. For the example when the tissue is animal pericardium, the smooth or visceral side of the pericardium should engage the outer surface 14 with the more rough side exposed. Typically at least a central part 26 of the tissue 20 is maintained in completely against the surface 14, and it is this part of the tissue that is used to form a calotte-shaped sheath in accordance with an aspect of the present invention.

[0032] While the example of FIG. 3 illustrates sutures being utilized to temporarily attach the tissue relative to the base 10, it is to be appreciated that other means also may be utilized to hold the tissue relative to the base in accordance with an aspect of the present invention. For example,

suitable hooks or clamps could be employed to secure the tissue relative to the base 10 or other appropriate structure.

[0033] FIG. 4 illustrates an example of a system 30 that may be employed to fix the tissue 20 to a desired shape in accordance with an aspect of the present invention. In this example, the system 30 includes a chamber 32 that contains a volume of a suitable fixation solution 34. The combination of the tissue 20 attached to the base 10 is immersed into the fixation solution 34 for sufficient period of time so as to fix the tissue that is exposed to the solution to substantially the same shape as the outer surface 14 of the base. By way of example, the fixation solution 34 is a solution that includes glutaraldehyde, which is well known in the art. A time period of about twenty-four hours in a glutaraldehyde solution should be sufficient to fix the tissue 20.

[0034] The tissue 20 may then be removed from the solution 34 and detached from the base 10. The tissue 20 is then trimmed to a desired size to form a calotte-shaped sheath 40, such as shown in FIG. 5. When the sheath 40 is to be used in neurosurgery as substitute dura mater, for example, the sheath may have diameter from about 10 cm to about 14 cm, although other sized sheaths also could be formed in accordance with an aspect of the present invention. The trimmed peripheral portion may be discarded or used to form other implantable tissue products.

[0035] After initial fixation and trimming, the calotte-shaped sheath 40 may be placed back in a suitable solution, such as may contain glutaraldehyde, for additional curing. In particular, the natural tissue sheath 40 further may be cross-linked with glutaraldehyde and undergo a detoxification process with heparin bonding, such as according to the NO-REACT® treatment process from Shelhigh, Inc. of Millburn, N.J. The NO-REACT® tissue treatment process helps improve the biocompatibility of the sheath 40.

[0036] FIG. 6 illustrates another system 50, in accordance with an aspect of the present invention, which may be employed to form an implantable calotte-shaped sheath 40. The system 50 includes a base 52 having a curved, generally semi-spherical (e.g. convex) outer surface 54. For example, the base 52 may be hollow bowl, although any structure having a desired outer surface 54 could be used. A sheet of biological tissue 20 is placed onto the outer surface 54 of the base 52, as shown in FIG. 6.

[0037] In contrast to the sutures and apertures utilized in the system of FIGS. 3 and 4, a generally tubular apparatus 58, such as a hollow cylinder, is used to hold the tissue 20 in a desired position relative to the base 52. In particular, the tubular apparatus 58 has a tissue-engaging end 60 that engages the tissue 20 and sandwiches the tissue between the outer surface 54 and the end 60. The engagement between the tissue-engaging end 60 and the tissue 20 may form a substantially liquid tight seal. In order to improve the seal, a rubber or other soft material may be provided at the end 60. As a result, an interior surface 62 of the tubular apparatus 58 and a portion 64 of the tissue 20 extending within the end 60 define a volume for holding a fixation solution 34. That is, the fixation solution 34 may be provided into the tubular apparatus 58 to fix the portion 64 of the tissue 20 within the annular end 60 to substantially the same shape as the outer surface contacted thereby. If some of the solution 34 leaks through the juncture between the tubular apparatus 58 and the tissue 20, the fluid simply would need to be replenished.

Advantageously, the weight of the fixation solution **34** further helps to hold the central portion **64** of the tissue **20** against the outer surface **54** to promote a desired shape during fixation.

[0038] After fixing the tissue **20** for a suitable time period (e.g., about twenty-four hours), the tissue may then be removed from the system **50** and trimmed to form a calotte-shaped sheath **40**, such as shown in FIG. 5.

[0039] While the apparatus **58** is shown and described as being generally cylindrical it is to be appreciated that other shapes also could be used in accordance with the present invention. Typically, however, the tissue-engaging end **60** of the apparatus should conform to the contour of the outer surface **54** and have a sufficient diameter so as to fix a desired portion **64** of the tissue **20**.

[0040] FIG. 7 illustrates yet another example of a system **80** that may be utilized, in accordance with an aspect of the present invention, to form a calotte-shaped sheath **40** of tissue. The system **80** includes a base portion **82** having a convex inner surface **84**. The base portion **82**, for example, may be a bowl similar to the other system arrangements shown and described herein. An appropriate support apparatus **86** may be employed to hold the base portion **82** in a desired position, such that an open end **88** faces upwards. In this example, sheet of tissue **20** is placed against the inner surface **84** of the base. For the example where the tissue **20** is animal pericardium, the smooth side engages the inner surface **84**. The tissue **20** may be smoothed out by hand (or by a suitable instrument) so that at least a substantial portion (e.g., a central portion) of the tissue **20** is substantially flush against the inner surface **84** the base **82**.

[0041] After the tissue is at a desired position, a volume of a suitable fixation solution **34**, such as may include glutaraldehyde, is added to a volume defined by the sheath **20** within the base **82**. The weight of the fixation solution **34** helps maintain engagement between at least a substantial portion of the tissue **20** and the inner surface **84**, thereby promoting fixation of the tissue to the desired shape. In order to facilitate engagement between the tissue **20** and the inner surface **84**, a cup-shaped member, such as felt or other diffusible material, may be placed over the tissue within the base to help hold the tissue against the inner surface **84** of the base **82**. After the tissue **20** has been fixed for a suitable time phase, the tissue may be removed and trimmed to a desired shape, such as to form the calotte-shaped sheath shown in FIG. 5.

[0042] FIGS. 8-12 and the accompanying description illustrate an example of a method that can be implemented to provide a curved sheath of tissue in accordance with an aspect of the present invention. For purposes of simplicity of illustration, identical reference numbers refer to corresponding parts throughout FIGS. 8-12.

[0043] FIG. 8 illustrates a generally flat sheet **100** of flexible material that can be utilized to form a curved sheath of tissue in accordance with an aspect of the present invention. The sheet **100** includes ends **102** and **104** that are spaced apart from each other by a pair of elongated side edges **106** and **108**. For example, the sheet **100** can be a flexible sheet of animal tissue, such as pericardium or another suitable thin sheet of tissue (e.g., dura matter, molded collagen, etc.). When pericardium is used, the sheet **100** includes a visceral side **110** that is generally smoother than the other side **112**.

[0044] In accordance with an aspect of the present invention, the side edges **106** and **108** are urged toward each other so that the intermediate portion of the sheet **100** extending between such edges has a curved shape. As shown in FIG. 9, for example, the side edges **106** and **108** are connected together, such as by sutures **114**, to form a tube **116** of the biological tissue material having a generally cylindrical sidewall **118**. Other types of retaining mechanisms also could be utilized to secure the edges **106** and **108** relative to each other, such as clips, fasteners, etc.

[0045] Thus, from FIG. 9, it will be appreciated that the sheet **100** can be employed to form a generally cylindrical sidewall having desired diameters at each of its ends **102** and **104**, which diameters can be the same or different. That is, the resulting structure **116** can be frusto-conical. Because, at this stage, the tissue of the sheet **100** is flexible (e.g., formed of relatively fresh natural tissue), it is flacid and thus tends to collapse to a relatively flat tube **116**, such as shown in FIG. 9.

[0046] In accordance with an aspect of the present invention, part of the sheet **100** is urged against a curved surface. The combination of sheet **100** and curved surface are immersed in a fixation solution so that at least that part of the sheet **100** takes on the contour of the curved surface.

[0047] With reference to the example of FIG. 10, the biological tube **116** is depicted as being mounted over a curved mandrel **120**. As shown in FIG. 10, for example, the tube is mounted over a curved mandrel having a generally circular cross section. Alternatively, the mandrel **120** can have a varying cross-sectional diameter and/or have a plurality of ribs or circumferentially extending corrugations. The particular dimensions and configuration of the mandrel **120** can vary according to the desired shape and size of the tissue being formed in accordance with an aspect of the present invention.

[0048] In one aspect the elongated mandrel **120** extends arcuately between its ends **122** and **124**. For example, the arcuate extent of the mandrel **120** has a radius of curvature that is greater than about forty-five degrees and, in another aspect, could have a radius of curvature greater than about ninety degrees, as shown in FIG. 10. The curved mandrel **120** also has an outer cross-sectional diameter that approximates or is slightly greater than the inner diameter of the biological tube **116**. As a result, the tube **116** is held on the mandrel **120** by friction.

[0049] While FIGS. 9 and 10 have been shown and described as creating the tube **116** and then sliding the tube over the mandrel **120**, it is to be understood that the sheet **100** could be wrapped around and secured relative to the mandrel. For example, the ends **106** and **108** of the sheet **100** can be urged around and secured relative to the mandrel, such as by sutures **114** or by clamps, retaining bands, and the like.

[0050] In accordance with an aspect of the present invention, the assembly that includes the biological tube **116** and the curved mandrel **120** are immersed in a fixation solution, such as including an aldehyde solution (e.g., glutaraldehyde). Accordingly, at least the part of the sheet **100** exposed to the fixation solution assumes the contour of the mandrel **120** that such tissue engages. After appropriate fixation, the tube **116** can be removed from the mandrel **120** to provide

a curved tubular sheath **126** such as shown in **FIG. 11**. Additional fixation may be implemented relative to the curved tubular sheath **126**. As a result, the tubular sheath **126** is permanently fixed to provide an arcuately extending cylindrical sidewall **118** corresponding to the configuration of the mandrel **120**.

[0051] In accordance with an aspect of the present invention, the tubular sheath **122** can be trimmed to a desired shape and size. In one particular aspect, as shown in **FIG. 12**, the suture line **114** and some adjacent tissue extending coextensively with the sheath **122** between the ends **102** and **104** can be excised from the tubular sidewall **118**. As a result, an elongated curved sheath **124** of tissue is formed, which sheath has a generally C-shaped cross section extending between its ends **102** and **104**. The sheath **124** has elongated side edges **130** and **132** that extend arcuately between the spaced apart ends **102** and **104** of the sheath. As a result, the sheath **124** has the appearance of a curved trough or gutter. Because of the fixation process, the sheath **128** maintains its C-shaped cross section (e.g., based on the circumference of the mandrel) as well as its arcuate length (e.g., corresponding to the radius of curvature of the mandrel).

[0052] The fixed tissue sheath **128** as well as the tubular sheath **126** can be detoxified to improve the biocompatibility thereof. By way of illustration, the sheath can be cross-linked with glutaraldehyde and undergo a detoxification process with heparin bonding, such as according to the NO-REACT® treatment process. The NO-REACT® tissue treatment process helps improve the biocompatibility of the sheath and render the sheath substantially cytocompatible.

[0053] The curved C-shaped cross section of the sheath **124** facilitates reconstruction and repair of vessels, such as part of a vessel enlargement. For example, the side edges **126** and **128** can be anastomosed to exposed side edges of a patient's vessel, such as an artery or vein. It is to be appreciated that the curved length of tubular material, such as shown in **FIG. 11**, also provides a useful conduit, such as may be employed to repair or replace a curved vessel or be attached to a heart valve prosthesis.

[0054] By way of illustration, **FIGS. 13-15** show part of a procedure (e.g., the Norwood procedure) that utilizes a curved sheath of tissue to repair a defective aorta in accordance with an aspect of the present invention.

[0055] **FIG. 13** illustrates a heart **200** having a congenital cardiac malformation, such as may occur in an infant suffering from hypoplastic left heart syndrome. As is apparent from the figure, the heart **200** includes a diminutive ascending aorta **202**, such as due to severe aortic valve hypoplasia or aortic valve atresia. Thus, one aspect of the procedure is to enlarge the diameter of the aortic arch. Also, as shown in **FIG. 13**, the main pulmonary trunk **204** extends from the outflow of the left ventricle **206**, with left and right pulmonary arteries **208** and **210** branching from the main trunk. The descending aorta **212** also is coupled to the pulmonary artery via a ductus vessel **214**.

[0056] As shown in **FIG. 14**, the main trunk of the pulmonary artery **204** has been transected adjacent to the take off at the right pulmonary artery **210**. The main pulmonary artery stump is closed, such as by suturing a patch **216** (e.g., a NO-REACT® pericardial patch or a homograft)

thereto. The aorta **212** also has been separated from the pulmonary artery by removing the ductus **214**.

[0057] The aorta **202**, **212** also is illustrated in an open condition, such as after having been opened by an axial incision **218**. The incision **218** extends from the descending aorta **212** to the ascending aorta **202** near a level proximal the exposed rim of the main pulmonary artery trunk **204**.

[0058] A curved sheath **220** of biocompatible biological tissue material is anastomosed to the open aorta to enlarge the aorta in accordance with an aspect of the present invention. For example, the sheath **220** has a generally C-shaped cross section and extends arcuately along its length (see, e.g., **FIG. 12**). The sheath **220** includes side edges **222** that extend arcuately between ends **224** and **226**. The end **224** of is sewn to the descending aorta **212**. The side edges **222** of the curved sheath **220** are then sutured to the exposed edges of the aortic arch defined by the incision **218**.

[0059] An aperture can be formed through the patch near the end **224** thereof for an aorto-pulmonary shunt, which may be operatively coupled between the aperture and the pulmonary artery. The shunt, for example, could be a short cylinder of a biological tissue material, such as a length of a fixed tubular length of biocompatible material (see, e.g., **FIG. 11**). Alternatively, the shunt could be formed of a PTFE material or other suitable biocompatible material.

[0060] The end **226** of the sheath **220** and part of the ascending aorta, which define an augmented aorta, are then anastomosed to the main pulmonary artery **204**. This provides an outflow path from the right ventricle **206** to the augmented aorta. Advantageously, the native portion of the augmented aorta can continue to grow with the patient.

[0061] It is to be appreciated that a curved sheath **124**, **220** of biological tissue material can be useful in the repair or reconstruction of other types of defects and diseases. In particular, the curved sheath can be utilized in non-cardiac procedures (e.g., neurosurgery, bladder repair, etc.). In addition, while a single arcuate curve is illustrated as extending between the ends of the sheath, it is to be appreciated that any number of curves can be implemented in a sheath in accordance with an aspect of the present invention. The particular dimensions and configuration of a sheath being produced will vary according to its intended application.

[0062] What has been described above includes examples of the present invention. It is, of course, not possible to describe every conceivable combination of components or methodologies for purposes of describing the present invention, but one of ordinary skill in the art will recognize that many further combinations and permutations of the present invention are possible. Accordingly, the present invention is intended to embrace all such alterations, modifications and variations that fall within the spirit and scope of the appended claims. Furthermore, to the extent that the term "includes" and variants thereof or the term "having" and variants thereof are used in either the detailed description or the claims, each such term is intended to be inclusive in a manner similar to the term "comprising."

What is claimed is:

1. A method for making a sheath having a curved contour, comprising:

- providing a sheet of a biological tissue material, the sheet having ends spaced apart from each other by elongated side edges;
- mounting the sheet to an elongated member having a curved exterior portion such that at least a substantial portion of the sheet engages the exterior portion;
- placing the sheet and elongated member in a fixation solution so that at least part of the sheet is fixed to a configuration defined by the exterior portion of the elongated member engaged thereby; and
- separating the sheet from the elongated member to provide an elongated sheath of substantially biocompatible material having a curved contour corresponding to the curved exterior portion of the elongated member.
2. The method of claim 1, prior to placing the sheet and elongated member in a fixation solution, the method further comprising:
- forming a generally tubular apparatus with the sheet of the biological tissue material; and
- urging the elongated member into the tubular apparatus.
3. The method of claim 2, the elongated member having a generally cylindrical sidewall portion that extends arcuately between opposite ends thereof.
4. The method of claim 2, the sidewall portion of the elongated member having a radius of curvature extending between the opposite ends thereof that is greater than about forty-five degrees.
5. The method of claim 3, the elongated member having an outer diameter that approximates the diameter of the tubular apparatus.
6. The method of claim 2, the forming further comprising securing the side edges of the sheet of biological material relative to each other, such that when the elongated member is urged into the tubular apparatus, the relative spacing between the side edges of the sheet of biological material remains substantially unchanged.
7. The method of claim 6, further comprising removing a strip of tissue adjacent and coextensive at least one of the side edges to form an elongated sheath having a curved contour that extends arcuately between opposite ends thereof and having generally C-shaped cross section.
8. An elongated sheath produced according to claim 7, the elongated sheath having a curved contour extending arcuately between opposite ends thereof and having generally C-shaped cross section.
9. The method of claim 5, the securing of the side edges further comprising suturing the side edges relative to each other to define a suture line that extends between the ends of the tubular apparatus.
10. The method of claim 8, further comprising removing the suture line to define an elongated sheath having a curved contour that extends arcuately between opposite ends thereof and having generally C-shaped cross section.
11. The method of claim 1, wherein the biological tissue material comprises animal pericardium.
12. An elongated sheath produced according to claim 1.
13. A method of making an implantable sheath having a curved contour, comprising:
- providing a sheet of tissue, the sheet having ends spaced apart from each other by elongated side edges;
- placing the sheet into engagement with a surface of an elongated member, the surface being curved about a long axis that extends between ends of the elongated member;
- urging the side edges of the sheet toward each other so as to cover at least part of the curved surface of the elongated member;
- fixing the sheet in a fixation solution so that at least part of the sheet assumes a contour defined by the at least part of the curved surface of the elongated member engaged by the sheet; and
- separating the sheet relative to the elongated member to provide an elongated sheath of substantially biocompatible material having a curved contour corresponding to the at least part of the curved surface of the elongated member.
14. The method of claim 13, the urging further comprising applying retaining elements to hold the sheet relative to the elongated member such that at least a substantial portion of the sheet engages the at least part of the curved surface of the elongated member.
15. The method of claim 14, the retaining elements including sutures that connect the opposed side edges of the sheet.
16. The method of claim 15, the sutures being applied to connect the side edges prior to placing the sheet into engagement with the elongated member.
17. The method of claim 14 further comprising removing the retaining elements after fixation to provide a curved sheath having a generally C-shaped cross section.
18. The method of claim 14, the elongated member extending arcuately between spaced apart ends of the elongated member according to a radius of curvature, such that after fixation the curved sheath extends arcuately between the ends of the sheet according to radius of curvature.
19. The method of claim 14, further comprising removing the retaining elements together with a strip of tissue from the sheet located adjacent and coextensive to at least one of the side edges of the sheet to form an elongated sheath having a curved contour that extends arcuately between opposite ends thereof and having generally C-shaped cross section.
20. A curved implantable sheath comprising:
- an elongated sheet of biological tissue material having first and second ends spaced apart from each other by opposed side edges;
- the elongated sheet extending arcuately between the first and second ends according to a radius of curvature; and
- the side edges of the elongated sheet being urged toward each other about a central axis that extends arcuately between the first and ends according to the radius of curvature to define a generally C-shaped cross section of the curved sheath, the curved sheath having undergone a fixation process to maintain such configuration.