



INTERNATIONAL APPLICATION PUBLISHED UNDER THE PATENT COOPERATION TREATY (PCT)

<p>(51) International Patent Classification ⁷ : B62B 13/04, B61B 11/00</p>	<p>A1</p>	<p>(11) International Publication Number: WO 00/13956 (43) International Publication Date: 16 March 2000 (16.03.00)</p>
<p>(21) International Application Number: PCT/GB99/02988 (22) International Filing Date: 8 September 1999 (08.09.99) (30) Priority Data: 9819593.6 8 September 1998 (08.09.98) GB (71)(72) Applicant and Inventor: SILVER, Andrew, George [GB/GB]; 41 Canfield Road, Woodford Bridge, Essex IG8 8JL (GB). (74) Agents: MOLYNEAUX, Martyn, W. et al.; Langner Parry, 52/54 High Holborn, London WC1V 6RR (GB).</p>		<p>(81) Designated States: AE, AL, AM, AT, AU, AZ, BA, BB, BG, BR, BY, CA, CH, CN, CU, CZ, DE, DK, EE, ES, FI, GB, GD, GE, GH, GM, HR, HU, ID, IL, IN, IS, JP, KE, KG, KP, KR, KZ, LC, LK, LR, LS, LT, LU, LV, MD, MG, MK, MN, MW, MX, NO, NZ, PL, PT, RO, RU, SD, SE, SG, SI, SK, SL, TJ, TM, TR, TT, UA, UG, US, UZ, VN, YU, ZA, ZW, ARIPO patent (GH, GM, KE, LS, MW, SD, SL, SZ, UG, ZW), Eurasian patent (AM, AZ, BY, KG, KZ, MD, RU, TJ, TM), European patent (AT, BE, CH, CY, DE, DK, ES, FI, FR, GB, GR, IE, IT, LU, MC, NL, PT, SE), OAPI patent (BF, BJ, CF, CG, CI, CM, GA, GN, GW, ML, MR, NE, SN, TD, TG).</p> <p>Published <i>With international search report.</i></p>

(54) Title: SNOW-TYPE BIKE

(57) Abstract

A board bike has a frame (50) supporting a saddle (61) and a steering mechanism (54 - 57) that steers a forward ski member (72). The frame (50) is mounted to a rear ski member (67) and the frame carries a pair of footrests (62). The rear ski member and, preferably the front ski member (72), have substantially the same width as the overall width of the footrests. The handlebars are, preferably, shaped to accommodate a drag lift poma or other tow lift.

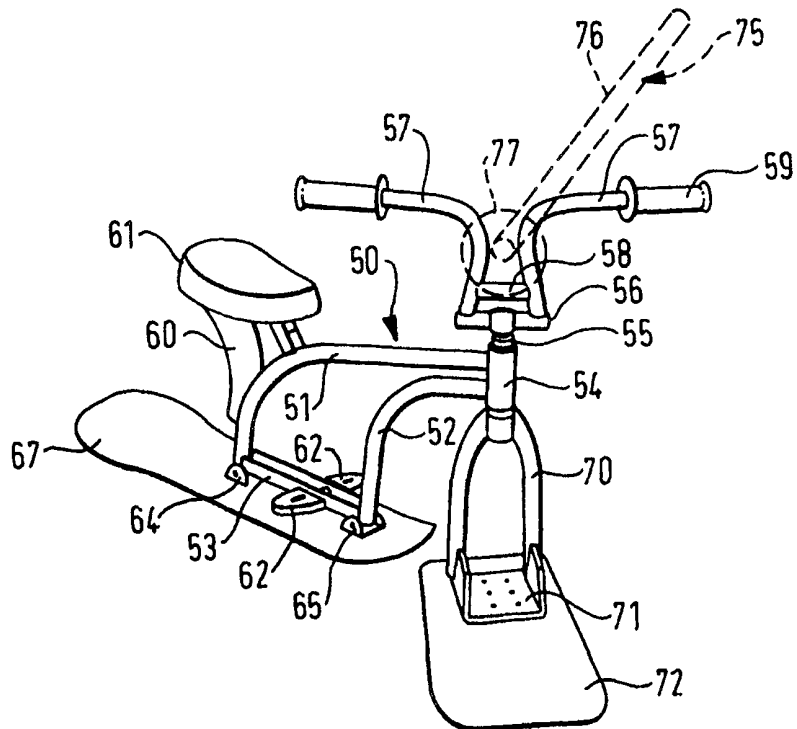

FOR THE PURPOSES OF INFORMATION ONLY

Codes used to identify States party to the PCT on the front pages of pamphlets publishing international applications under the PCT.

AL	Albania	ES	Spain	LS	Lesotho	SI	Slovenia
AM	Armenia	FI	Finland	LT	Lithuania	SK	Slovakia
AT	Austria	FR	France	LU	Luxembourg	SN	Senegal
AU	Australia	GA	Gabon	LV	Latvia	SZ	Swaziland
AZ	Azerbaijan	GB	United Kingdom	MC	Monaco	TD	Chad
BA	Bosnia and Herzegovina	GE	Georgia	MD	Republic of Moldova	TG	Togo
BB	Barbados	GH	Ghana	MG	Madagascar	TJ	Tajikistan
BE	Belgium	GN	Guinea	MK	The former Yugoslav Republic of Macedonia	TM	Turkmenistan
BF	Burkina Faso	GR	Greece			TR	Turkey
BG	Bulgaria	HU	Hungary	ML	Mali	TT	Trinidad and Tobago
BJ	Benin	IE	Ireland	MN	Mongolia	UA	Ukraine
BR	Brazil	IL	Israel	MR	Mauritania	UG	Uganda
BY	Belarus	IS	Iceland	MW	Malawi	US	United States of America
CA	Canada	IT	Italy	MX	Mexico	UZ	Uzbekistan
CF	Central African Republic	JP	Japan	NE	Niger	VN	Viet Nam
CG	Congo	KE	Kenya	NL	Netherlands	YU	Yugoslavia
CH	Switzerland	KG	Kyrgyzstan	NO	Norway	ZW	Zimbabwe
CI	Côte d'Ivoire	KP	Democratic People's Republic of Korea	NZ	New Zealand		
CM	Cameroon			PL	Poland		
CN	China	KR	Republic of Korea	PT	Portugal		
CU	Cuba	KZ	Kazakstan	RO	Romania		
CZ	Czech Republic	LC	Saint Lucia	RU	Russian Federation		
DE	Germany	LI	Liechtenstein	SD	Sudan		
DK	Denmark	LK	Sri Lanka	SE	Sweden		
EE	Estonia	LR	Liberia	SG	Singapore		

SNOW-TYPE BIKE

This invention relates to a snow-type bike sometimes known as a ski bob or snowscoot.

5 Snow-type bikes have become popular with snow sport enthusiasts, and a known bike, more particularly a ski bob, is shown in Figure 1. This known snow-type bike has a frame 1 formed of a crossbar 2 to which is secured a seat pillar 3 and a handlebar headset 4. Pivotaly mounted in the headset is a
10 handlebar column 5, the lower end of which is pivotally mounted in the headset and the upper end of the column 5 is secured to a pair of user-operable handlebars 6. The handlebars are connected through the column 5 in the headset 4 to a column 7 that is connected via a suspension unit 8 to a
15 forward ski 9. The pillar 3 is attached to a seat saddle 10 and the saddle is attached by a strut 11 to a rearward end of a rear ski 12 through a suspension unit 14, the forward end of the rear ski 12 being attached by a support member 13 to the headset. The terms "forward" and "rear" used herein refer to
20 directions in use, i.e. leading and trailing. Such a known ski bob is ridden by a user who wears a pair of foot skis 15 so as to stabilise the user. Thus, in use, the ski bob is ridden and steered by a user via the forward ski 9 and, of necessity, has their feet on the snow through the intermediary
25 of the foot skis for stability.

A further form of snow-type bike, which is known as a snowscoot, is shown in Figure 2. In this form of device, there is an inverted Y-shaped frame 20 connected to a headset 24 which pivotally locates a column 25 supporting a pair of
30 handlebars 26. The lower end of the column 25 is connected to a pair of forks 27 with a lower end of the forks being connected to a forward ski 29. The frame 20 has a frame member 21 laterally centrally secured to a forward end of a rear ski 30 and another frame member 22 laterally centrally

connected toward a rearward end of the rear ski 30. The rear ski 30 supports a platform 31 having an upturned rear end and at a forward end is located a strap 32 for securing a user's feet, in use located one on each side of the frame member 22.

5 In use of the device of Figure 2, a user stands with both feet on the rear ski 30 and steers the device by the handlebars 26.

It is known that users of BMX bikes like to jump over obstacles and to perform freestyle movements of the bikes and
10 of themselves when in mid-air, and a similar desire exists with snow enthusiasts. Neither of the forementioned devices are able to permit such freestyle use to the level and style found in BMX-ing. In the former device of Figure 1, a user, of necessity, has to use a pair of foot skis because the rear
15 ski 12 is too narrow to support a user, and in the snowscoot of Figure 2 a user's feet are secured to the rear ski which may cause a user injury in a crash. Furthermore, the snowscoot of Figure 2 does not have a seat.

The present invention seeks to at least partially
20 mitigate the foregoing disadvantages.

According to this invention there is provided a snow-type bike for use in snow comprising frame means supporting seat means for a user and steering means; a rear ski member attached to said frame means; a forward ski member attached to
25 said steering means; footrest means extending on each side of said frame means at a location between said seat means and the plane of said rear ski member.

Preferably, footrest means is located on said frame means or on said rear ski member.

30 Preferably, the forward and rear ski members have a width two or more times, preferably four times, the width of a normal recreation ski.

Conveniently, the front and rear ski members have the same width.

Preferably, said frame means comprises first and second frame members each joined at a respective first end thereof to a headset member and joined at a second, opposed end thereof to a third frame member, said third frame member being located 5 substantially parallel to said rear ski member, said third frame member carrying said footrest means.

Preferably, the footrest means comprise a pair of footrests extending one on each side of said frame means.

Conveniently, the vicinity of the juxta position of the 10 first and third frame members and the second and third frame members forms a securing location of the frame means to the rear ski member.

Advantageously, the first frame member supports the seat means.

15 Preferably, the headset pivotally supports the steering means which comprises a pair of handlebars attached to at least one fork member, a lower end of at least one fork member being attached to the forward ski member.

Advantageously, a pair of fork members are provided.

20 Advantageously, the handlebars at a location in the vicinity of the headset are shaped and spaced to accommodate a drag lift or other tow lift.

Preferably, the fork members are pivotally attached directly or indirectly to the forward ski member.

25 Advantageously, the forward ski member is pivotally attached to the fork members for movement about at least one of an axis which is transverse to the longitudinal direction of the frame means and an axis which is along the longitudinal direction of the frame means, both said axes 30 being defined when the forward and rear ski members are aligned.

Advantageously, the rear ski member is pivotally attached to the frame means for movement about a longitudinal axis of the frame means.

In an embodiment of the invention the frame means is attached to the rear ski member by suspension means and, advantageously, the steering means may be attached to the forward ski member through the intermediary of one or more
5 suspension members.

Where the front ski member is pivotally connected to the steering means, preferably means are provided for damping pivotal motion of said front ski member.

Advantageously, the frame means is attached to the rear
10 ski member at longitudinally spaced locations of the frame and means are provided for permitting the rear ski member to flex between said spaced locations.

In this invention the footrest means are located above the rear ski member giving substantial room for a user's feet
15 to extend over the edge of the rear ski member, if desired, without the user's feet hitting the ground. A user is, thus, able to stand on the footrest means with their legs slightly apart giving a more natural stance during normal riding. The invention has the following advantages:

20 1. A user can absorb greater vertical impact from a jump without exerting masses of forward or backward lean which impairs control and stability.

2. A user can take greater vertical impact from a jump, absorbing the pressure through the bike and the user's
25 legs simultaneously.

3. A user can ride over rough ground more freely.

4. A user's feet are not restricted by skis, as in Figure 1, or a strap, as in Figure 2, so that a user is able to perform a greater number of popular freestyle manoeuvres.

30 5. Without the requirement of skis on a user's feet, as in Figure 1, or the strap of Figure 2, a user is less likely to sustain leg injury.

6. A user who has larger feet or who is wearing warmer, bulkier footwear will not have their performance

restricted as in the prior art.

The invention will now be described, by way of example, with reference to the accompanying drawings in which:

Figure 1 shows a perspective view of a prior art snow-type bike known as a ski bob,

Figure 2 shows a perspective view of a another prior art snow-type bike known as a snowscoot,

Figure 3 shows a perspective view of a snow-type bike in accordance with this invention, known as a BOARDBIKE™,

10 Figure 4 shows a partial side view of the snow-type bike of Figure 3,

Figure 5 shows a perspective view of a second embodiment of the present invention,

15 Figures 6(a) and 6(b) show mutually orthogonal partial views of an alternative embodiment of a snow-type bike of this invention having a damper for pivotal motion of the forward ski,

Figure 7 shows a partial side view of a rear ski member securement to a frame in an alternative embodiment of the 20 snow-type bike of this invention, and

Figure 8 shows a perspective view of a bracket used in the embodiment of Figure 7.

In the Figures like reference numerals denote like parts.

25 The snow-type bike shown in Figures 3 and 4 has a frame 50 formed of a first member 51 which forms a cross bar and a seat securement member, a second frame member 52 and a third frame member 53, the third frame member having opposed ends attached to respective ends of the first and second members 30 51, 52. Opposed ends of the frame members 51, 52 are secured to a headset 54. The headset pivotally locates a handlebar stem 55 which forms a T-section with a cross member 56. Opposed ends of the cross member 56 are attached to a respective one of a pair of user-operable handlebars 57 which

are braced in the vicinity of the cross member 56 by a bar 58.

The outer ends of each handlebar 57 are provided with a hand grip 59. The first member 51 carries at least one stay 60 and, preferably, there are two such stays 60 which support a seat 61. The third frame member carries, on each lateral side thereof, a footrest 62 preferably having an abrasive upper foot engaging surface, e.g. spikes, for a user, the lateral width of the footrest depending on the size of the bike, which, in turn, will depend upon the size of a user. It is envisaged that the footrests 62 will be substantially the width of a user's footwear, although a slightly narrower footrest could be used, provided that the footrest was comfortable to a user. The footrest may, if desired, be located on an upper surface of the rear ski member.

Secured in the vicinity of the juxta position of the first and third frame members and the second and third frame members via brackets 64, 65 is a rear ski member 67 which is substantially parallel to the third frame member 53. The rear ski member, preferably, has upturned front and rear ends and the rear ski member has a width substantially the same as that of the overall width of the footrest. However, if the footrest is located a sufficient height above the rear ski member, the footrest lateral width may be greater than that of the rear ski member. The reason for the rear ski member having substantially the same width as the footrest is so that the footrests do not contact the snow when cornering. Footrests are provided since, if a user places their feet directly on the rear ski member 67, the board forming the rear ski member flexes and the load imparted by the user's feet on the rear ski member affects directional stability.

The stem 55 is preferably connected through bearings or bushes in the headset 54 to a pair of front forks 70, although it is possible that a single fork member may be provided. The lower ends, in use, of the forks 70 are located in a U-shaped

bracket 71 that attaches the forks to a forward ski member 72. The forward ski member 72 may have an upturned front portion and the rear portion of the forward ski member 72 may also be upturned. The connection between the forks and the forward
5 ski member 72 may be pivotally located to permit the ski member to move in the direction of double arrow-headed lines 73, shown in Figure 4.

Preferably, the forward and rear ski members have a width two or more times, preferably four times, the width of a
10 normal recreation ski.

Conveniently, the front and rear ski members have the same width.

It is also envisaged that the frame 50 and the front fork 70 may be attached to the rear and forward ski members by
15 joints which permit the ski members to remain horizontal while the frame and forks tilt with respect thereto about a longitudinal axis of the frame, e.g. when cornering.

The handlebars 57 are shaped and arranged so as to accommodate between the respective handlebars a drag lift 75,
20 or other tow lift, shown in broken lines in Figures 3 and 4. In this respect, the handlebars are spaced so as to accept the drag lift pole 76, but to retain an end 77 which may be an enlarged circular end, as shown, or a T-shaped end, so that the board bike may be carried up a slope by a drag lift.

25 Although not shown in Figures 3 and 4, the frame could be mounted onto the rear ski member via the intermediary of suspension means and similarly the front forks 70 may be attached to the forward ski member by suspension means.

Referring to Figure 5, a second embodiment of the
30 invention is shown in which the frame is mounted on the rear ski member via a suspension.

The snow-type bike of Figure 5 has a frame 80 formed in the shape of a letter Y, the stem 81 of the Y-shape having one end attached to a headset 98, a first limb 82 of the Y-shape

being secured to a seat 83 and via a suspension device including a pneumatic or hydraulic strut 84 to a pivot in a bracket 85 secured to a rear ski member 86. The strut 84 is pivoted at its upper end to the first limb 82 and the strut is held in expansion by a compression spring 87. Another limb 88 of the Y-shape is bifurcated with one portion of the bifurcation being attached to footrests 89 located on respective opposing sides of the limb 88 and the other portion of the bifurcation is pivotally mounted to a link device 90. The link device 90 is formed of a first link 91 that has one end pivotally attached to the limb 88 and the other end thereof is pivotally attached to a further link 92, the link 92 being pivotally located in a U-shaped saddle member 93 that is secured to a forward end of the rear ski member 86.

The headset 98 pivotally supports the handlebars 57. The headset 82 is positioned intermediate an upper triangular member 94 and a lower triangular member 95 at the apex of the members 94, 95 with a pair of pillars 96 being provided as supports at a respective corner of the members 94, 95. Axially located below each of the pillars 96 on an opposite side of the lower triangular member 95 is a pair of front telescopic struts 97 which may be spring mounted. A lower end of the struts 97 are pivotally located on the U-shaped bracket 71 which is secured to the forward ski member 72.

In this embodiment, the rear ski member 86 is suspended to the frame 80 and the forward ski member 72 is also suspended to the steering mechanism by the struts 97. The front suspension in this embodiment is, however, optional.

The upper, foot engaging, surface of the footrests 62 and 89 may be provided with a high friction surface such as protruding spikes.

It will be understood that by having footrests located, in use, above the rear ski member 61, 86, so a user may lean the board bike when negotiating a turn or bend without the

user's feet contacting the ground, the amount of lean being dependent upon the height of the footrests above the rear ski member and the width of the rear ski member in relation to the width of the footrests although, as herein stated above, the width of both the rear and front ski members is more than twice and, preferably, four times the width of a normal recreational ski. The use of raised footrests also improves use of the snow-type bike for a user with larger feet or bigger boots.

10 A damper for a pivoting forward ski member is shown in Figures 6(a) and 6(b). The forks 70 are each pivotally attached by axles 110 that extend transversely to the longitudinal axis of the frame (the axis being defined when the forward and rear ski members are in alignment) to a transverse member 111 interconnecting the forks. Located below, in use, the member 111 is an elastomeric or rubber or other suitable resilient block 112, acting as a damper, although it is to be understood that any suitable shock absorbing means known per se may be alternatively used. The block 112 is mounted on a plate 113 for transmitting load to the forward ski 72 at a location forward of the axles 110. Not only does the damper block 112 damp pivoting of the forward ski, but it also permits a more controllable use of the snow-type bike, and also assists in reducing fracture of the forward ski member 72.

If the frame members 51 and 52 are fixedly secured to the rear ski member 67, it is possible that fracture of the rear ski member may occur. So as to reduce the risk of such fractures, the frame members 51 and 52 are fixedly or pivotally connected, as shown in Figure 7, to a forward (in use) bracket 120 and a rearwardly mounted bracket 121, the brackets 120, 121 being secured to the rear ski member 67 by rivets or bolts acting through resilient (e.g. rubber or elastomeric) bushings. Alternatively, the brackets 120, 121

may have a resilient member sandwiched between a lower surface of the brackets and an upper surface of the rear ski member 67.

One of the brackets 121 is shown in detail in Figure 8.
5 The bracket has a generally U-shaped form having a base 125 and opposed side faces 126 each with a hole 127 for securement to the frame members 51, 52. In a longitudinal direction of the frame the bracket has two pairs of slots 128 extending through the base 125. The bracket 120 may
10 also have similar slots 128 or may, alternatively, simply have circular holes. The slots 128 are fixing apertures for the bolts/rivets for attachment of the frame to the rear ski member 67. Because of the provision of slots 128, so the fixings which are resiliently mounted, and which are
15 securely fixed to the board, are able to move with respect to the bracket 121. Thus, if there should be flexing of the rear ski member 67, such flexing is permitted by virtue of the slots 128.

Although this invention has been described in relation
20 to a snow-type bike for use in snow, it is envisaged that the BOARDBIKE™ could be used on water or a man-made ski slope, if so desired.

The present invention outperforms the snowscoot in its ability to turn more easily. This is due to the seat which is
25 in a position that enables the user to lean against the frame with the inside of their leg to turn the bike effortlessly. The snowscoot does have a down frame member for this purpose, but it is not as effective.

On a snowscoot the user has to be right over the front
30 thereof to make full use of the down frame member and once a rider leans backwards, the frame member disappears from their range. Even when in range, the amount of leverage gained from the frame member is not as much as when leaning against the BOARDBIKE™. This is because the seat of this invention may

be soft and wide and a user of any size can use it to get leverage in all riding positions, even when they are leaning backwards away from the bike.

CLAIMS:

1. A snow-type bike for use in snow comprising frame means (50 - 53) supporting seat means (60, 61) for a user and
5 steering means (54 - 59, 70); a rear ski member (67) attached to said frame means; a forward ski member (72) attached to said steering means; footrest means (62) extending on each side of said frame means at a location between said seat means and the plane of said rear ski member.
- 10 2. A snow-type bike as claimed in claim 1, wherein the footrest means is located on said frame means or on said rear ski member.
- 15 3. A snow-type bike as claimed in claim 1 or 2, wherein the forward (72) and rear (67) ski members have a width two or more times the width of a normal recreation ski.
4. A snow-type bike as claimed in claim 3, wherein the
20 forward (72) and rear (67) ski members have a width four times the width of a normal recreation ski.
5. A snow-type bike as claimed in any preceding claim, wherein the front and rear ski members have the same width.
- 25 6. A snow-type bike as claimed in any preceding claim, wherein said frame means comprises first (51) and second (52) frame members each joined at a respective first end thereof to a headset member (54) and joined at a second, opposed end
30 thereof to a third frame member (53), said third frame member being located substantially parallel to said rear ski member (67), said third frame member carrying said footrest means (62).

7. A snow-type bike as claimed in claim 6, wherein the footrest means comprise a pair of footrests (62) extending one on each side of said frame means.
- 5 8. A snow-type bike as claimed in claim 6, wherein the vicinity of the juxta position of the first and third frame members and the second and third frame members forms a securing location of the frame means to the rear ski member.
- 10 9. A snow-type bike as claimed in any of claims 6 to 8, wherein the first frame member (51) supports the seat means (60, 61).
- 15 10. A snow-type bike as claimed in any of claims 6 to 9, wherein the headset (54) pivotally supports the steering means (55 - 59, 70) which comprises a pair of handlebars (57) attached to at least one fork member (70), a lower end of at least one fork member being attached to the forward ski member (72).
- 20 11. A snow-type bike as claimed in claim 10, wherein a pair of fork members are provided.
- 25 12. A snow-type bike as claimed in claim 10 or 11, wherein the handlebars at a location in the vicinity of the headset are shaped and spaced to accommodate a drag lift (75) or other tow lift.
- 30 13. A snow-type bike as claimed in claim 11 or 12, wherein the fork members (70) are pivotally attached directly or indirectly to the forward ski member.
14. A snow-type bike as claimed in claim 11, 12 or 13, wherein the forward ski member (72) is pivotally attached to

the fork members for movement about at least one of an axis which is transverse to the longitudinal direction of the frame means and an axis which is along the longitudinal direction of the frame means, both said axes being defined
5 when the forward and rear ski members are aligned.

15. A snow-type bike as claimed in any preceding claim, wherein the rear ski member (67) is pivotally attached to the frame means for movement about a longitudinal axis of the
10 frame means.

16. A snow-type bike as claimed in any preceding claim, wherein the frame means (80) is attached to the rear ski member (86) by suspension means (84, 85).

15

17. A snow-type bike as claimed in any preceding claim, wherein the steering means is attached to the forward ski member (72) through the intermediary of one or more suspension members (97).

20

18. A snow-type bike as claimed in any preceding claim, wherein, where the front ski member is pivotally connected to the steering means, there is provided means for damping pivotal motion of said front ski member.

25

19. A snow-type bike as claimed in any preceding claim, wherein the frame means is attached to the rear ski member (67) at longitudinally spaced locations of the frame and means (120, 121, 128) are provided for permitting the rear ski
30 member to flex between said spaced locations.

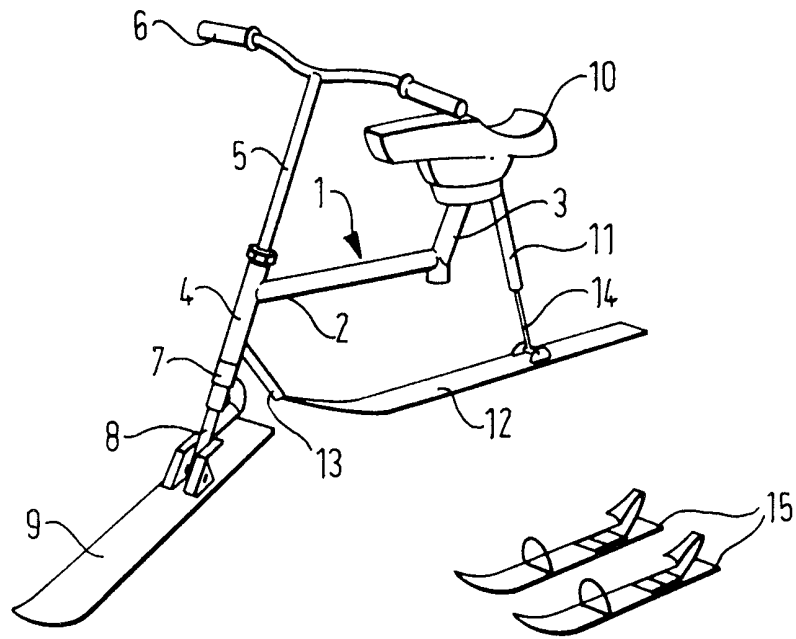

FIG. 1
PRIOR ART

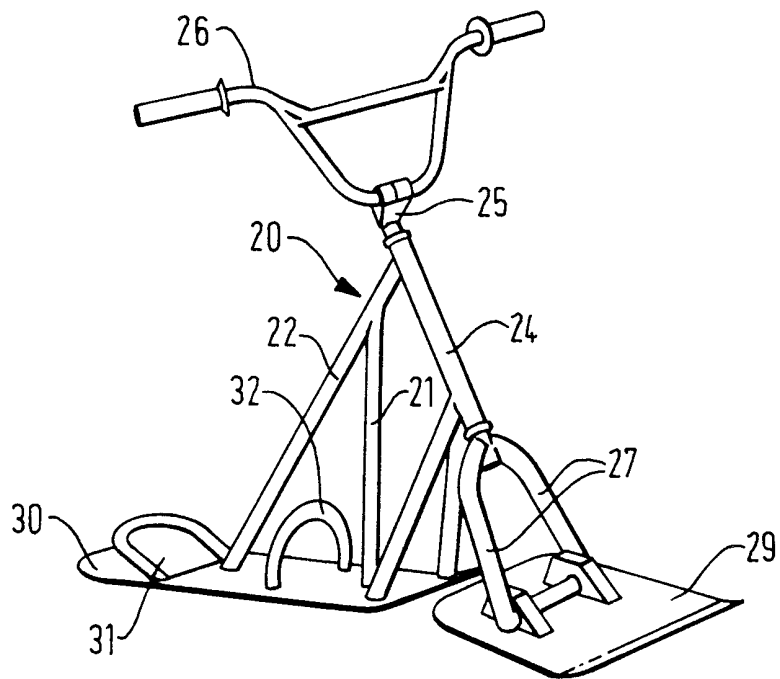

FIG. 2
PRIOR ART

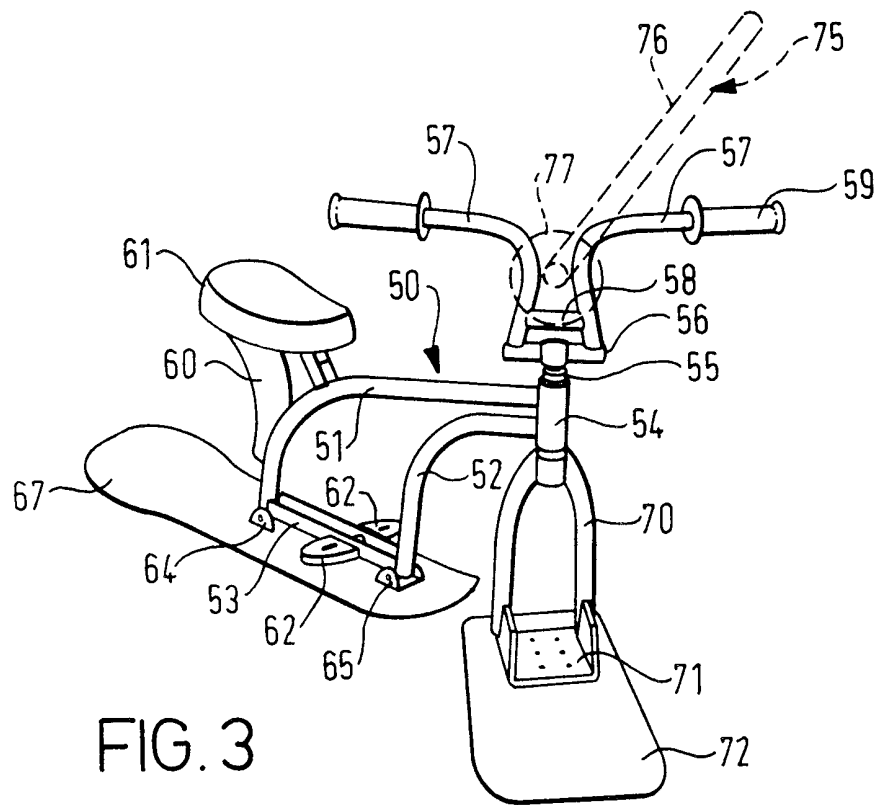

FIG. 3

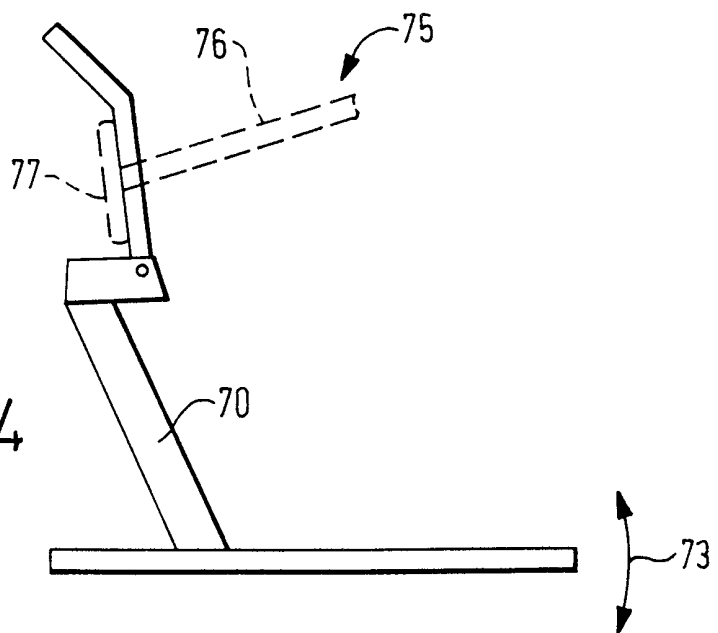

FIG. 4

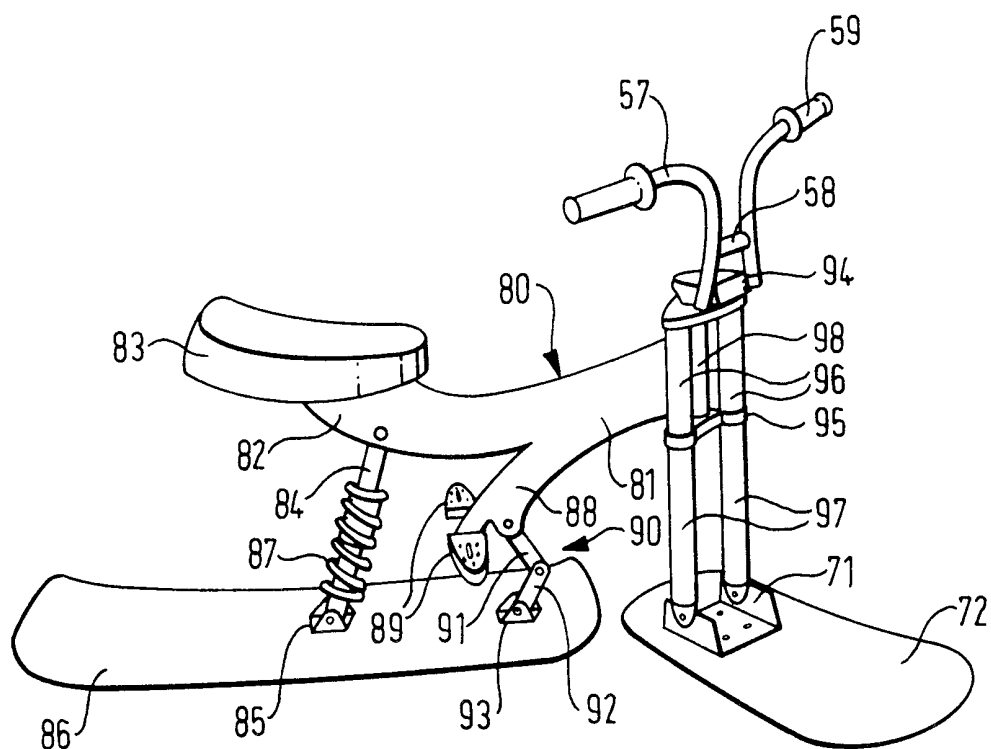

FIG. 5

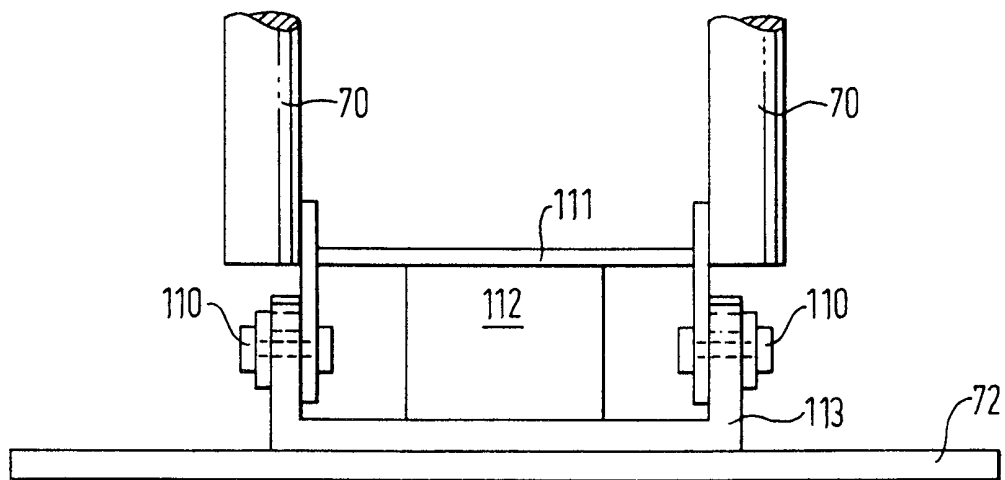

FIG. 6a

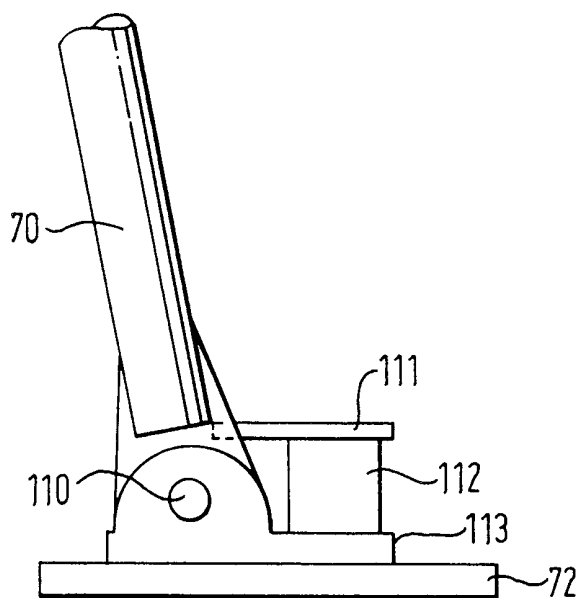

FIG. 6b

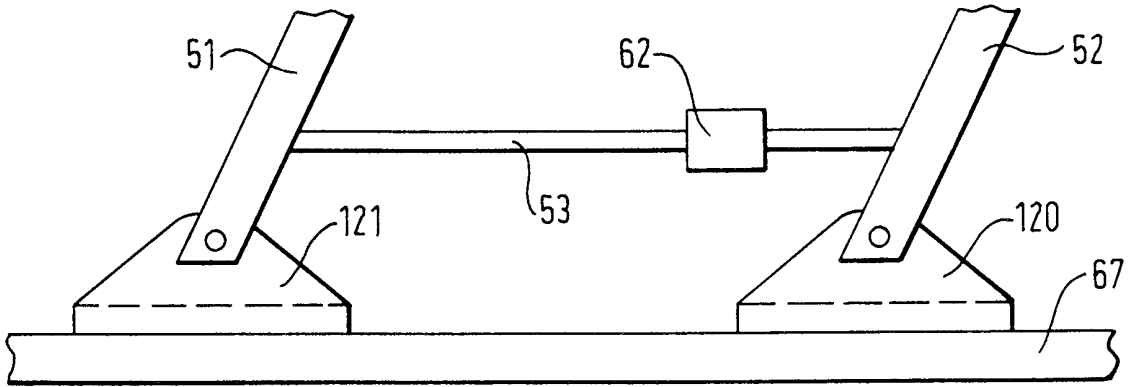

FIG. 7

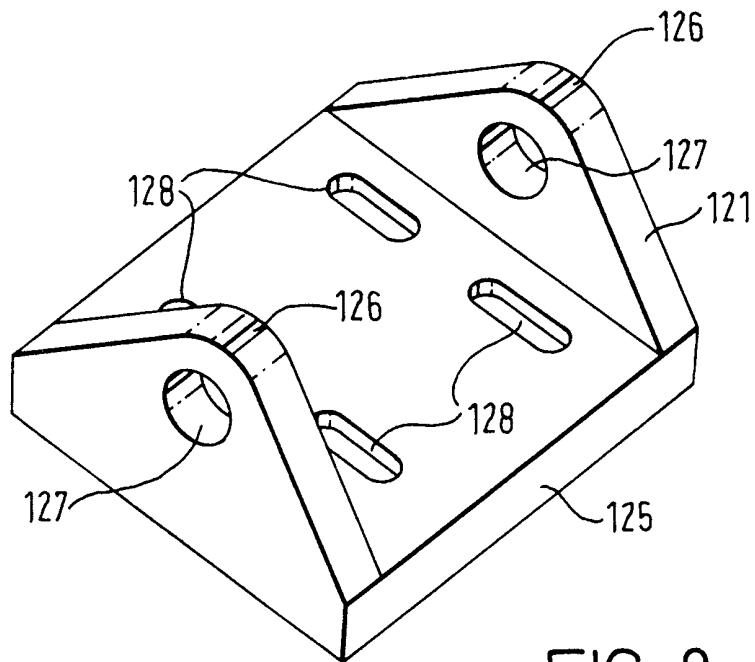

FIG. 8

INTERNATIONAL SEARCH REPORT

International Application No

PCT/GB 99/02988

A. CLASSIFICATION OF SUBJECT MATTER
 IPC 7 B62B13/04 B61B11/00

According to International Patent Classification (IPC) or to both national classification and IPC

B. FIELDS SEARCHED

Minimum documentation searched (classification system followed by classification symbols)

IPC 7 B62B B61B

Documentation searched other than minimum documentation to the extent that such documents are included in the fields searched

Electronic data base consulted during the international search (name of data base and, where practical, search terms used)

C. DOCUMENTS CONSIDERED TO BE RELEVANT

Category *	Citation of document, with indication, where appropriate, of the relevant passages	Relevant to claim No.
X	US 4 097 055 A (LAYCRAFT KEVIN WENDELL) 27 June 1978 (1978-06-27) the whole document	1, 2, 5-11, 13, 14, 17-19
X	FR 2 521 937 A (TRANVOIZ RENE) 26 August 1983 (1983-08-26) the whole document	1, 2, 5, 10-14
A	US 3 870 330 A (HATANO FUKUJI ET AL) 11 March 1975 (1975-03-11)	

Further documents are listed in the continuation of box C.

Patent family members are listed in annex.

* Special categories of cited documents:

- "A" document defining the general state of the art which is not considered to be of particular relevance
- "E" earlier document but published on or after the international filing date
- "L" document which may throw doubts on priority claim(s) or which is cited to establish the publication date of another citation or other special reason (as specified)
- "O" document referring to an oral disclosure, use, exhibition or other means
- "P" document published prior to the international filing date but later than the priority date claimed

- "T" later document published after the international filing date or priority date and not in conflict with the application but cited to understand the principle or theory underlying the invention
- "X" document of particular relevance; the claimed invention cannot be considered novel or cannot be considered to involve an inventive step when the document is taken alone
- "Y" document of particular relevance; the claimed invention cannot be considered to involve an inventive step when the document is combined with one or more other such documents, such combination being obvious to a person skilled in the art.
- "&" document member of the same patent family

Date of the actual completion of the international search

15 December 1999

Date of mailing of the international search report

22/12/1999

Name and mailing address of the ISA

European Patent Office, P.B. 5818 Patentlaan 2
 NL - 2280 HV Rijswijk
 Tel. (+31-70) 340-2040. Tx. 31 651 epo nl.
 Fax: (+31-70) 340-3016

Authorized officer

De Schepper, H

INTERNATIONAL SEARCH REPORT

Information on patent family members

International Application No

PCT/GB 99/02988

Patent document cited in search report		Publication date	Patent family member(s)	Publication date
US 4097055	A	27-06-1978	CA 1068751 A	24-12-1979
FR 2521937	A	26-08-1983	NONE	
US 3870330	A	11-03-1975	CA 998721 A	19-10-1976