

(12) **UK Patent Application** (19) **GB** (11) **2 333 874** (13) **A**

(43) Date of A Publication **04.08.1999**

(21) Application No **9909316.3**

(22) Date of Filing **14.05.1996**

Date Lodged **22.04.1999**

(30) Priority Data

(31) **08442795** (32) **17.05.1995** (33) **US**

(62) Divided from Application No **9610053.2** under Section **15(4)** of the Patents Act 1977

(51) INT CL<sup>6</sup>  
**H03K 19/177**

(52) UK CL (Edition Q )  
**G4H HU H13D H14B H14D**

(56) Documents Cited  
**None**

(58) Field of Search  
UK CL (Edition Q ) **G4H HU**  
INT CL<sup>6</sup> **H03K**

(71) Applicant(s)

**Altera Corporation**  
**(Incorporated in USA - California)**  
**2610 Orchard Parkway, Sunnyvale, San Jose,**  
**California 95134-2020, United States of America**

(72) Inventor(s)

**Richard G Cliff**  
**Srinivas T Reddy**  
**David E Jefferson**  
**Rina Raman**  
**L Todd Cope**  
**Christopher F Lane**

(72) cont

**Joseph Huang**  
**Francis B Heile**  
**Bruce B Pederson**  
**David Wolk Mendel**  
**Craig Schilling Lytle**  
**Robert Richard Noel Bielby**  
**Kerry Veenstra**

(74) Agent and/or Address for Service

**Withers & Rogers**  
**Goldings House, 2 Hays Lane, LONDON, SE1 2HW,**  
**United Kingdom**

(54) Abstract Title

**Programmable logic array**

(57) A programmable logic array integrated circuit device includes a plurality of regions of programmable logic with a universal signal conductor extending adjacent each region. A first programmable switch is associated with each region for selectively applying a signal on the universal signal conductor to the region as an input signal. A second programmable switch is provided for selectively applying to the universal signal conductor either a signal received by an input pin or an output signal from one of the regions.

**GB 2 333 874 A**

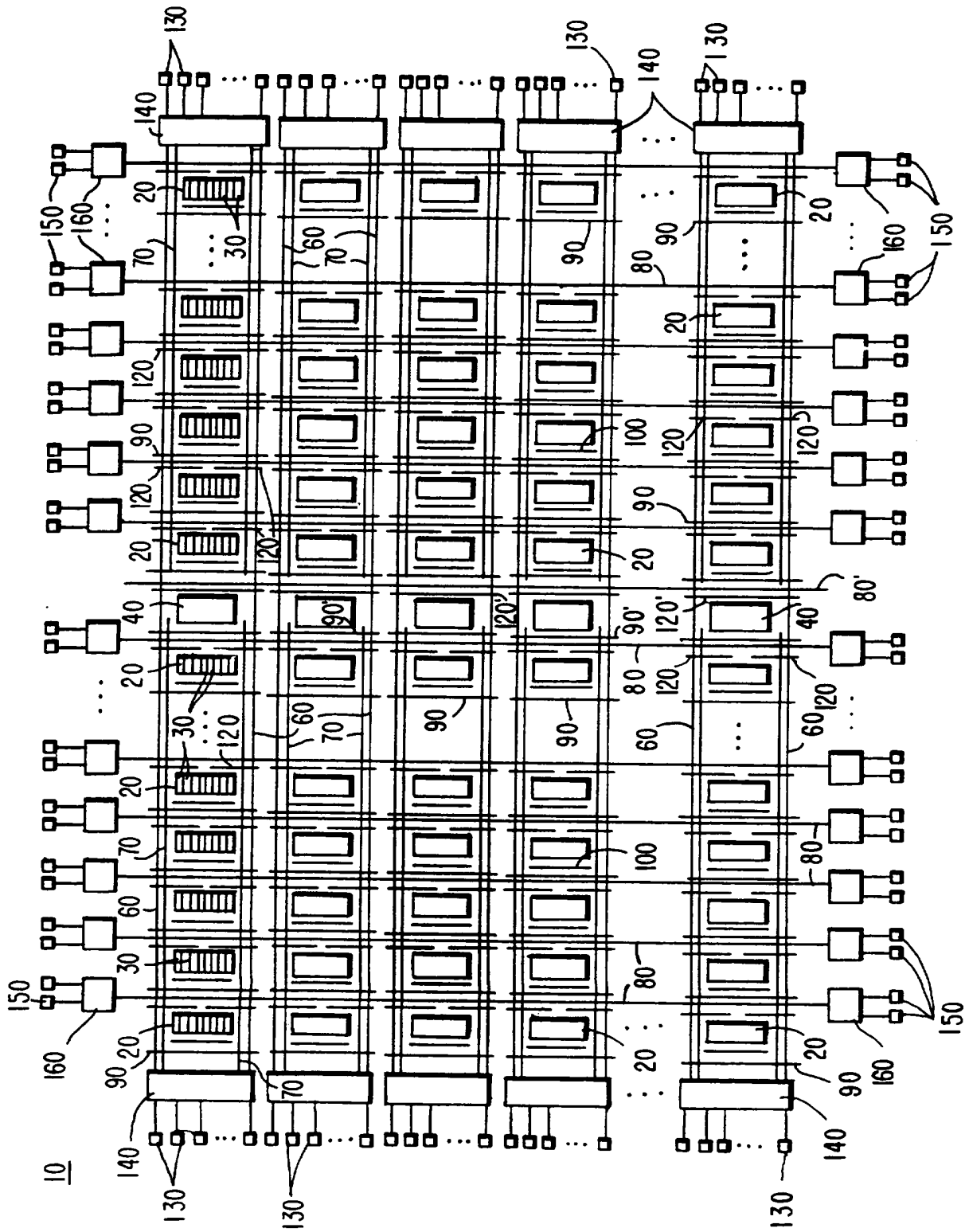

FIG. 1

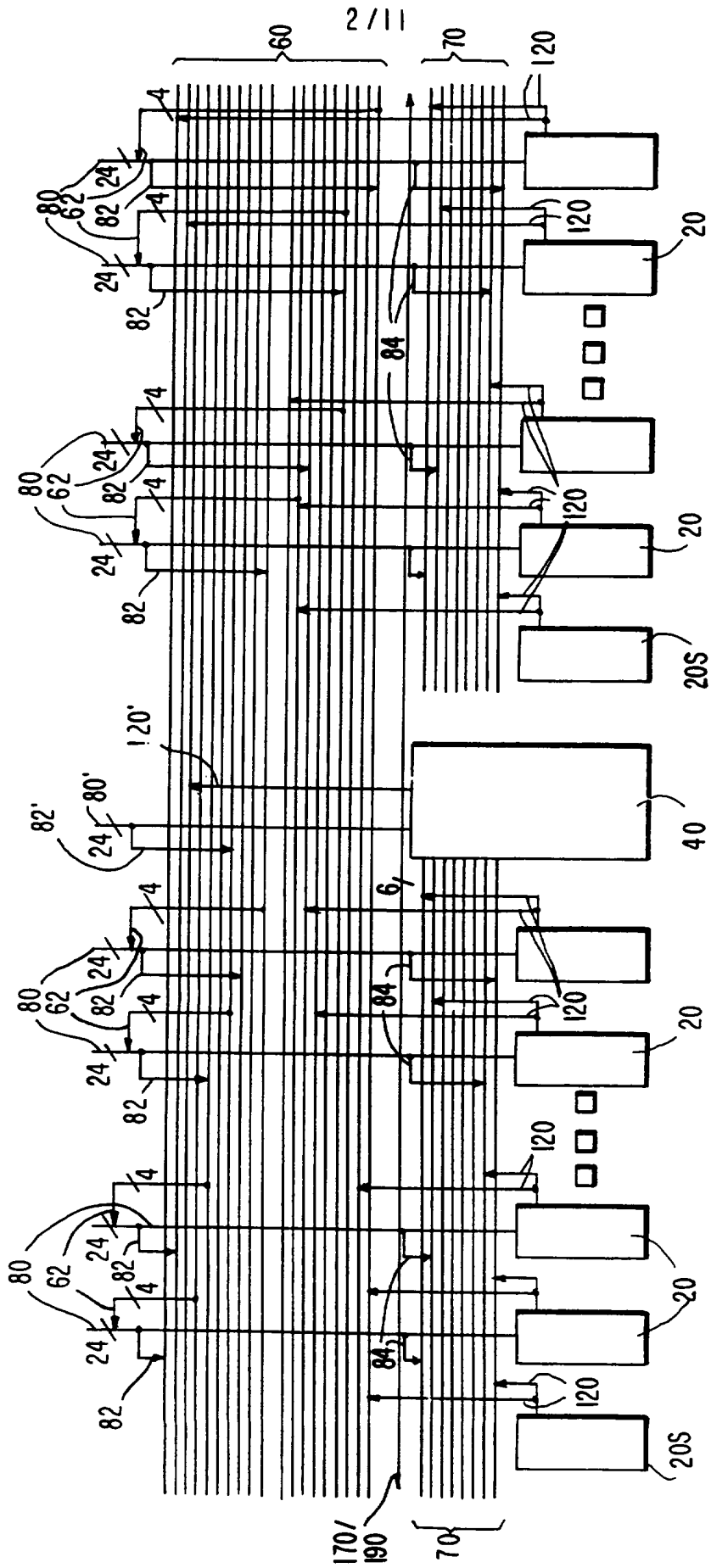
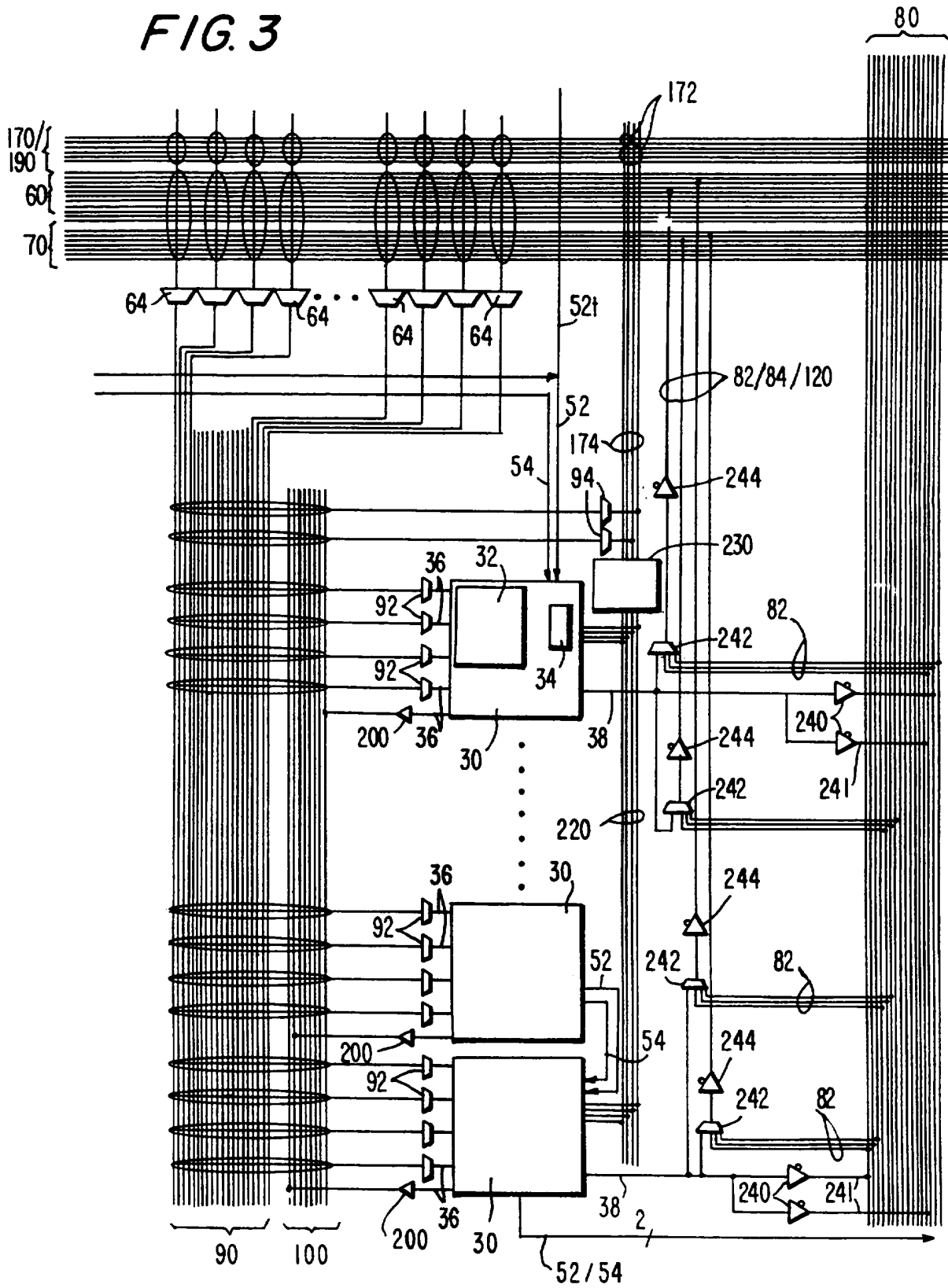

FIG. 2

FIG. 3



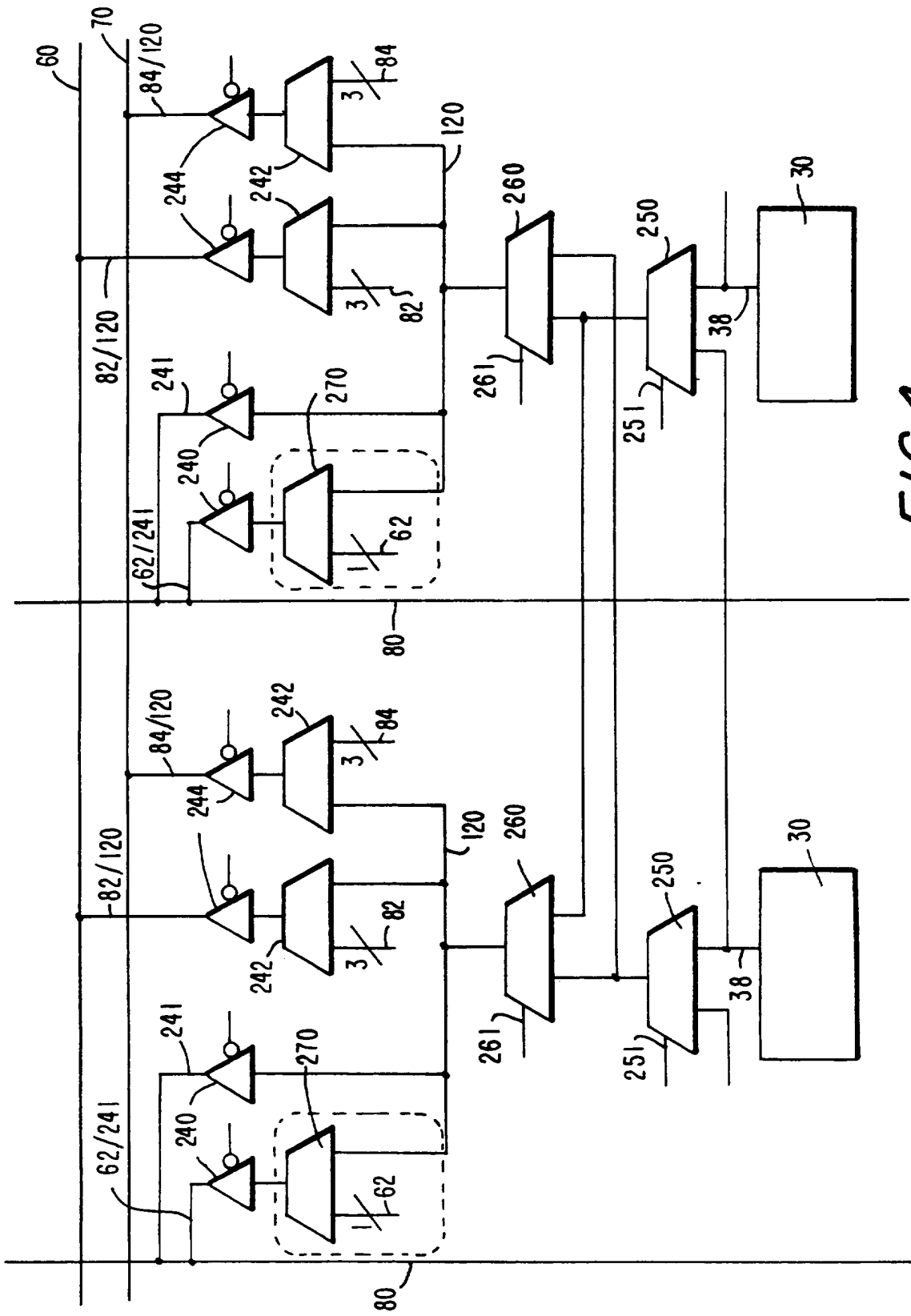
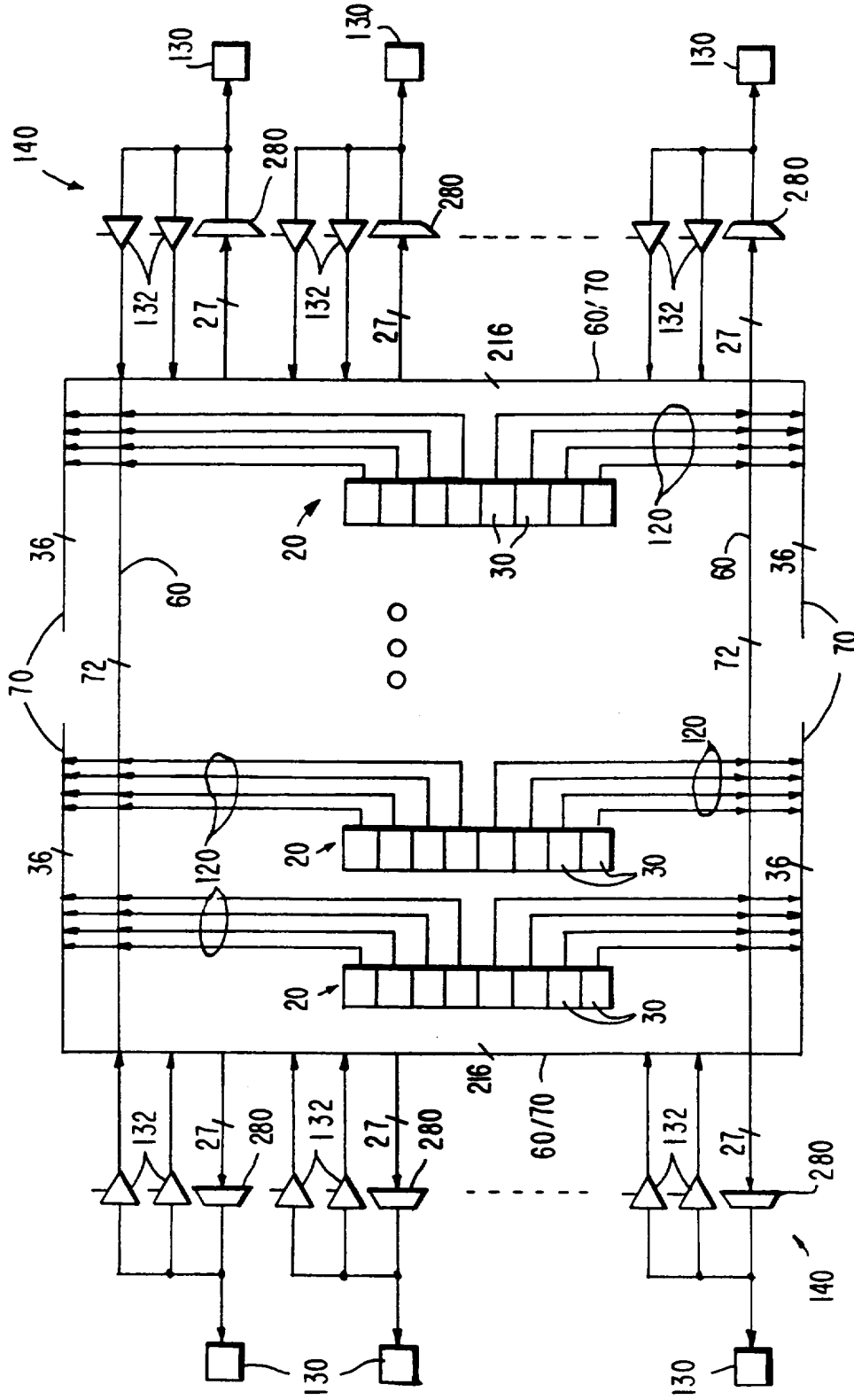

FIG. 4

**FIG. 5**



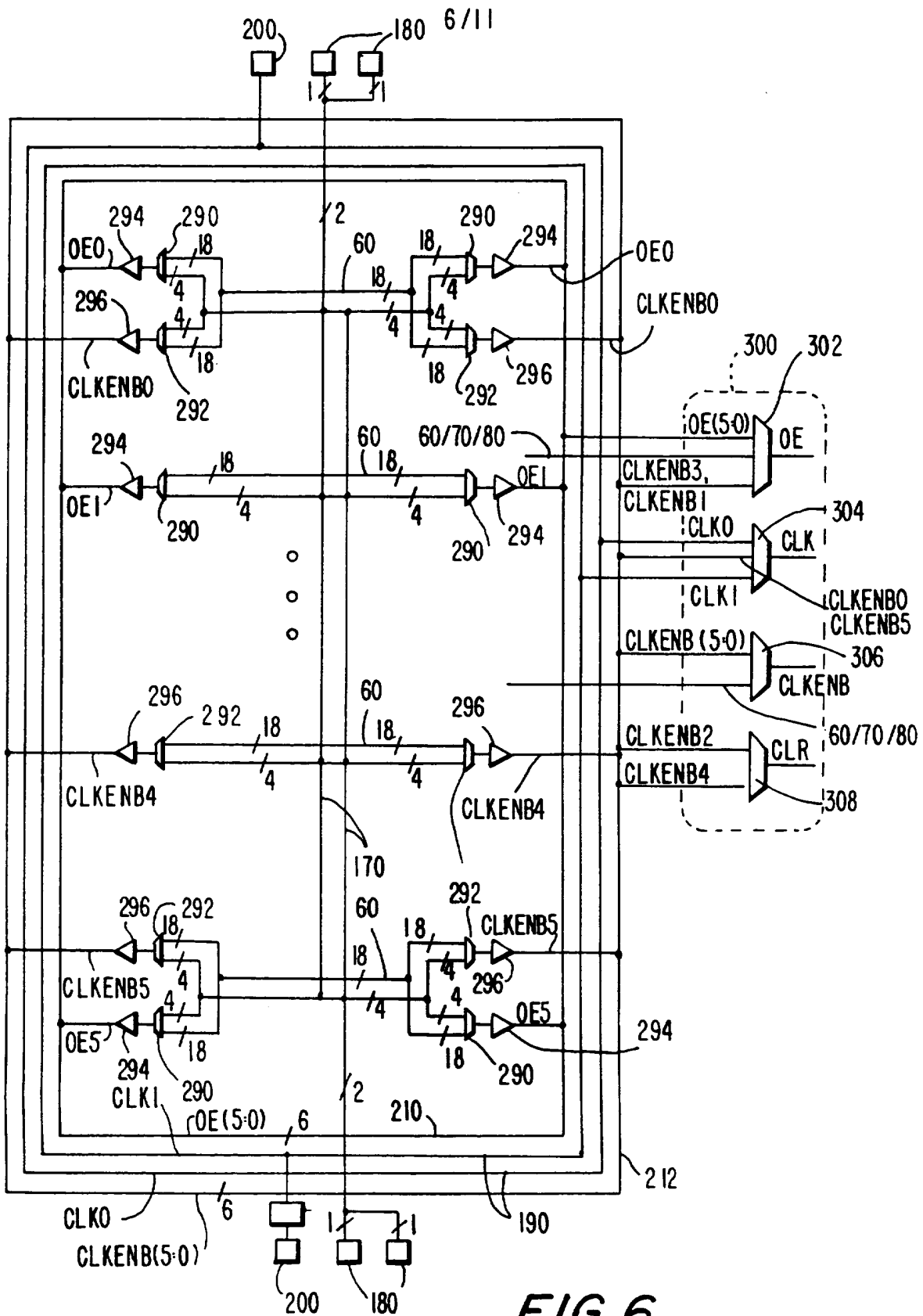

FIG. 6

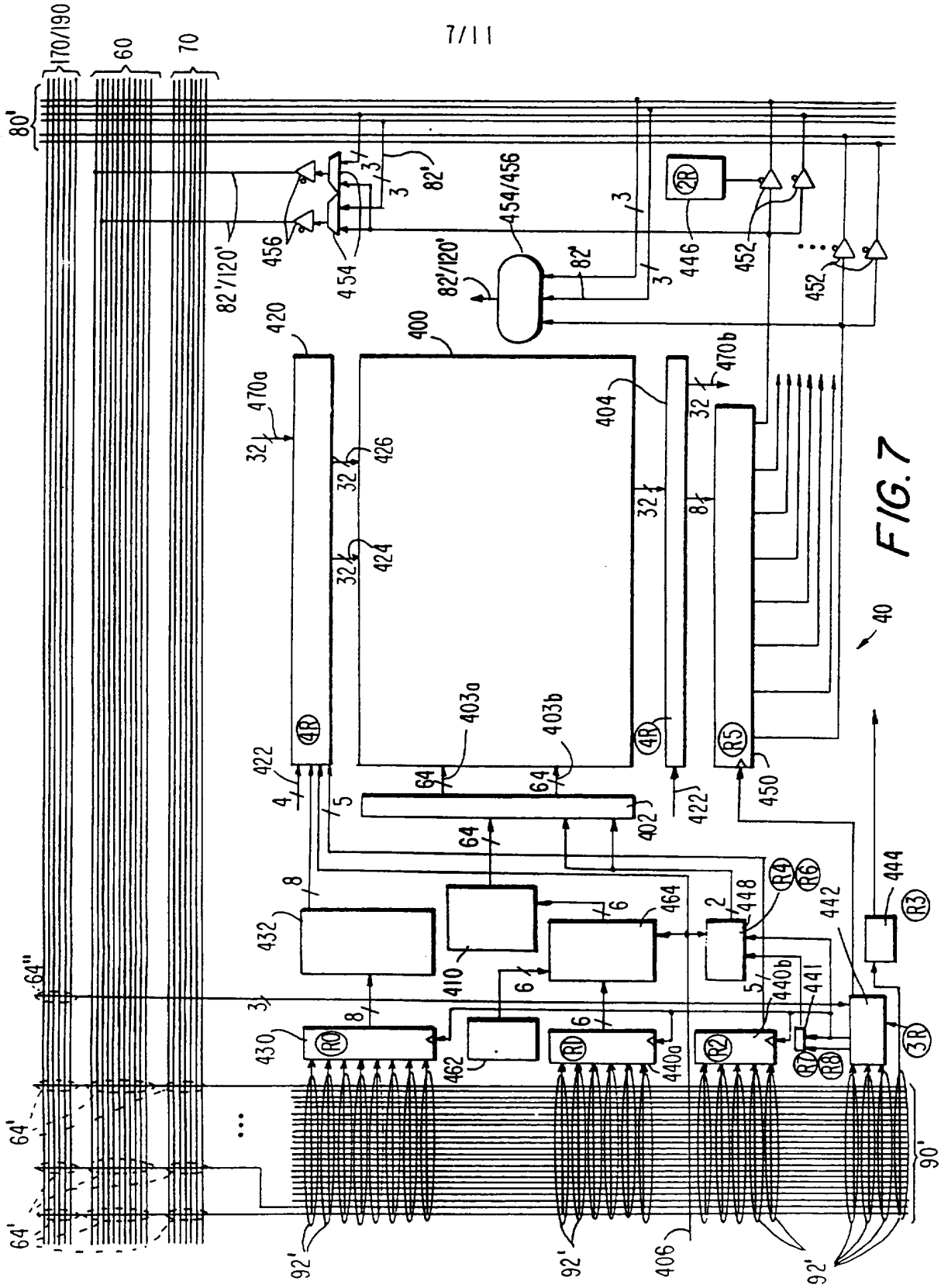

FIG. 7



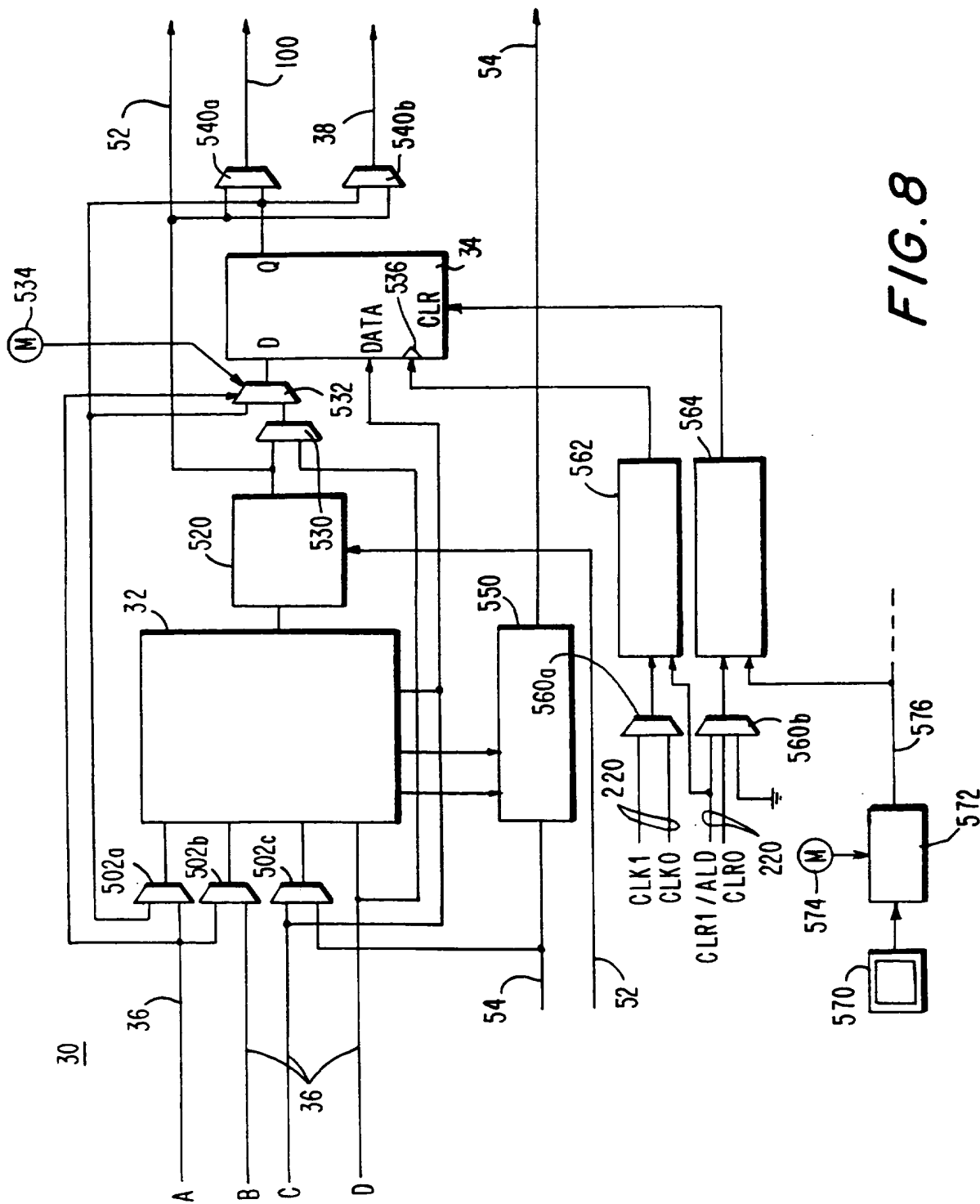

FIG. 8

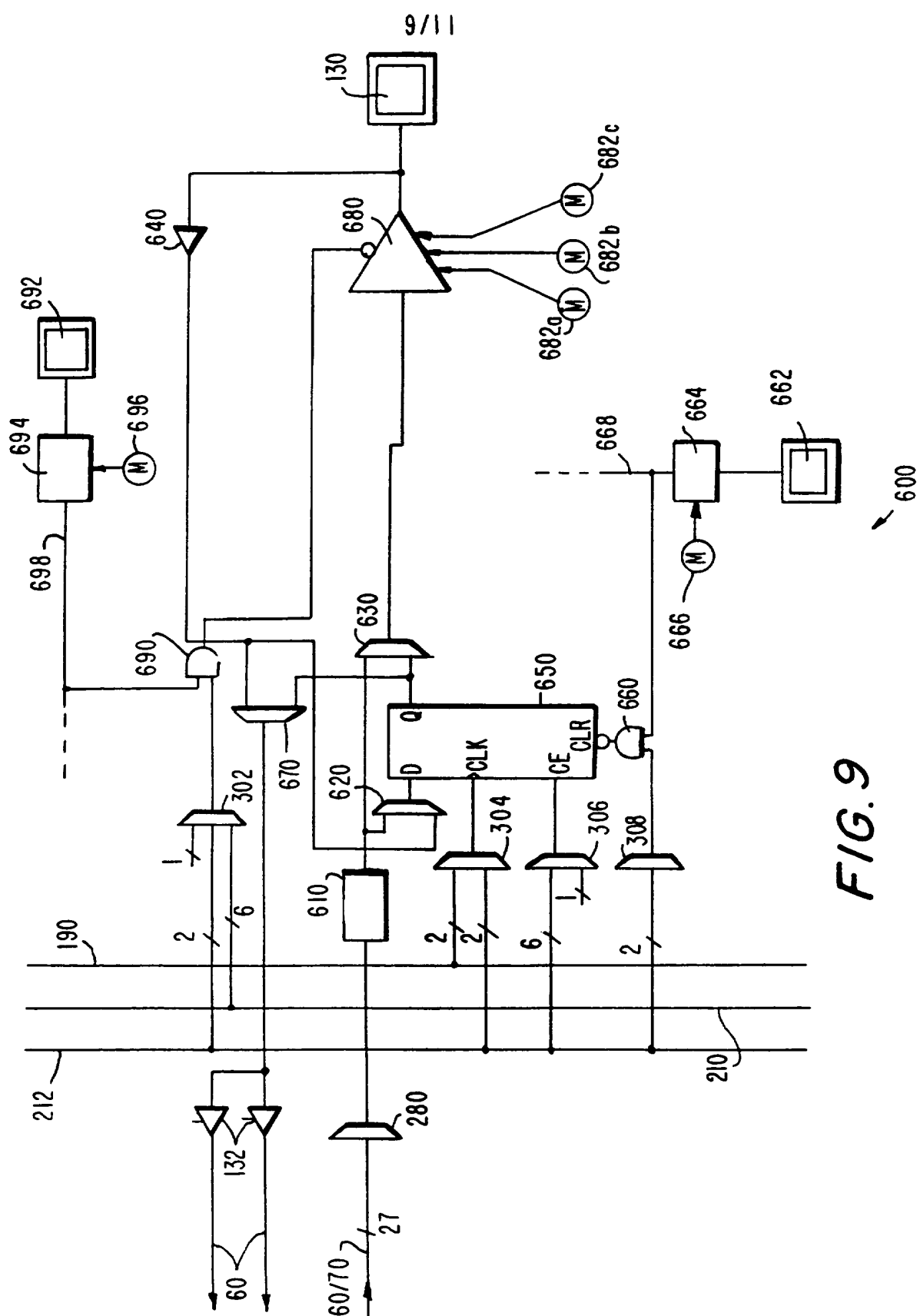

FIG. 9

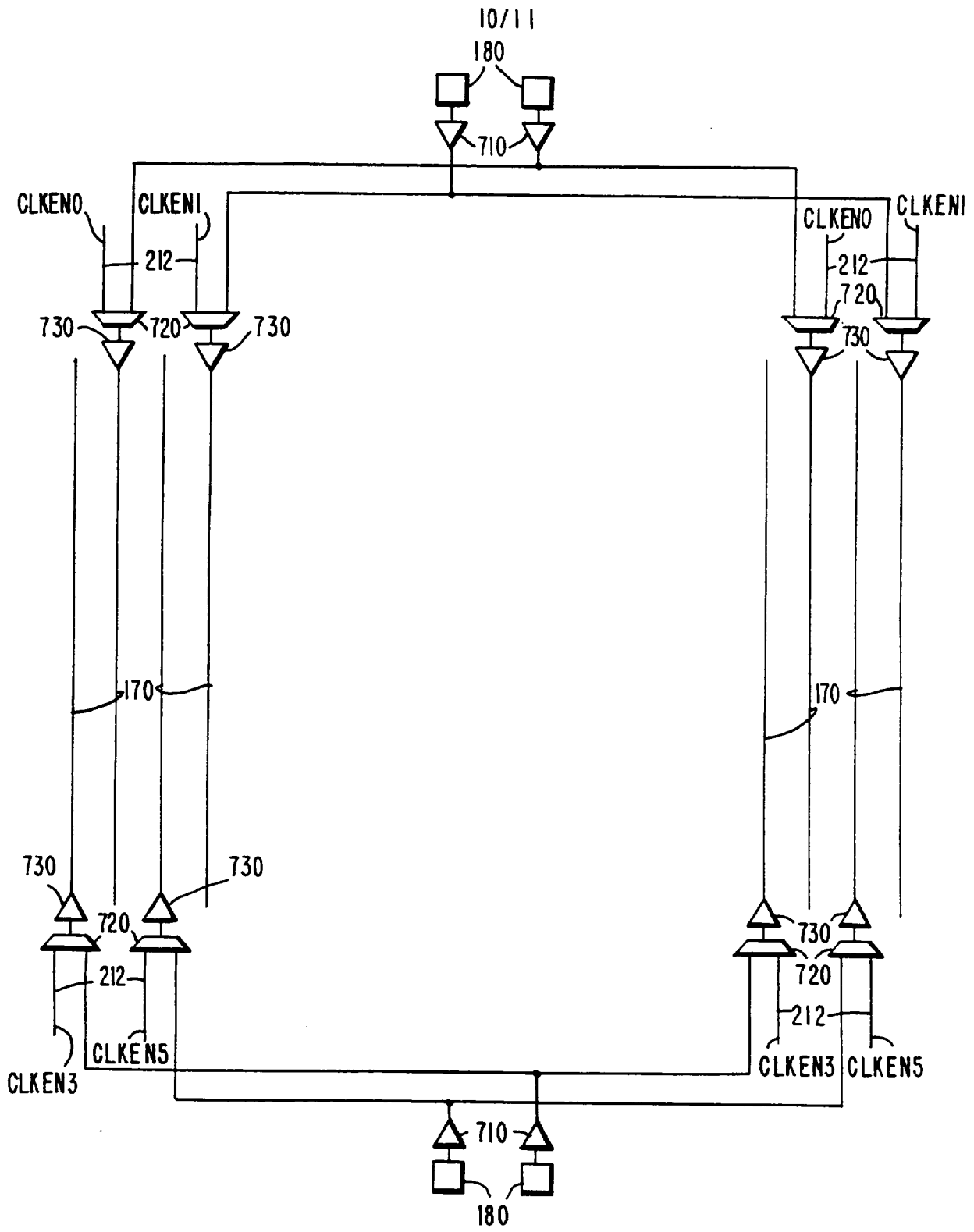

FIG. 10

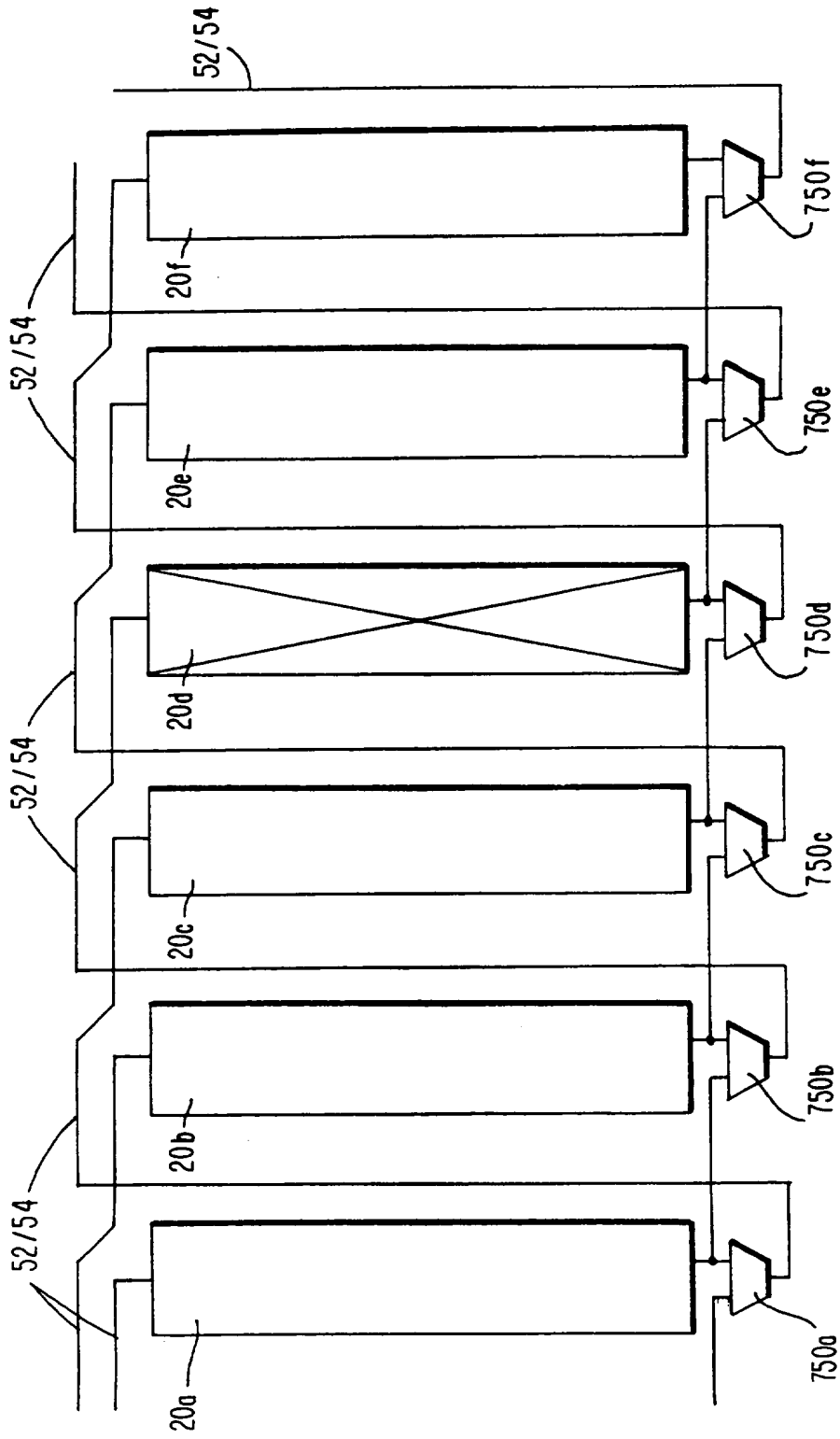

FIG. 11

**PROGRAMMABLE LOGIC ARRAY  
INTEGRATED CIRCUIT DEVICES**

**Background of the Invention**

This invention relates to programmable logic  
5 array integrated circuit devices, and more particularly  
to improved features for such devices (e.g., improved  
programmable interconnectivity between the programmable  
logic regions of such devices).

Programmable logic array integrated circuit  
10 devices are well known, as shown, for example by  
Pedersen et al. U.S. patent 5,260,610 and Cliff et al.  
U.S. patent 5,260,611. Such devices often include a  
large number of regions of programmable logic disposed  
on the device in a two-dimensional array of  
15 intersecting "rows" and "columns" of such regions.  
Each region is programmable to perform any of several  
logic functions on signals applied to the region. Each  
row may have associated "horizontal" conductors for  
conveying signals to, from, and/or between the regions  
20 in the row. Each column may have associated "vertical"  
conductors for conveying signals from row to row.  
Programmable connections may be provided for  
selectively connecting the conductors adjacent to each  
region to the inputs and outputs of the region, and  
25 also for selectively connecting various conductors to  
one another (e.g., connecting a horizontal conductor to  
a vertical conductor). Interconnection of regions

through the above-mentioned conductors and programmable connections makes it possible for the programmable logic array device to perform much more complicated logic functions than can be performed by the individual  
5 regions.

Advances in integrated circuit fabrication technology have made it possible to produce programmable logic array devices with very large numbers of logic regions. As the number of logic  
10 regions increases, however, it becomes increasingly important to select the numbers and arrangements of the interconnection conductors and the programmable connections between those conductors and the regions. Complete generality of these interconnection resources  
15 (i.e., so that any desired interconnection can be made no matter what other interconnections are made) would lead to exponential growth in the chip area occupied by those resources as the number of logic regions increases. This is especially disadvantageous in the  
20 case of reprogrammable devices because of the larger size and greater circuit loading and signal propagation delay of reprogrammable interconnection elements as compared to one-time-only programmable interconnection elements. (One-time-only programmable devices are  
25 shown, for example, El Gamal et al., "An Architecture for Electrically Configurable Gate Arrays," IEEE Journal of Solid-State Circuits, Vol. 24, No. 2, April 1989, pp. 394-98; El-Ayat et al., "A CMOS Electrically Configurable Gate Array," IEEE Journal of Solid-State  
30 Circuits, Vol. 24, No. 3, June 1989, pp. 752-62; and Elgamal et al. U.S. patent 4,758,745.) Moreover, most of any completely general interconnection resources would be unused and therefore wasted in virtually all applications of the device. On the other hand, many  
35 applications of the device may require substantial

interconnection resources, and because the device is intended to be a general-purpose device, it is extremely important to commercial success that the device be capable of satisfying a very wide range of potential applications, many of the requirements of which cannot be known in advance by the designer of the programmable logic array device.

Considerations such as the foregoing make it essential to provide increasingly sophisticated interconnection resources in programmable logic array devices, and especially in reprogrammable logic array devices. The aim is to hold down the fraction of the "real estate" of the chip that is devoted to interconnection resources, e.g., by optimizing various features of those resources, by increasing the flexibility with which those resources can be used, etc. Moreover, this is preferably done without undue circuit loading and speed penalties due to passing signals through excessive numbers of switches or tapping conductors to large numbers of switches. (Compare the above-mentioned El Gamal, El-Ayat, and Elgamal references, as well such other references as Freeman U.S. patent Re. 34,363 and Carter U.S. patent 4,642,487, all of which rely heavily on programmably piecing together relatively short conductor segments when longer conductors are needed.)

In view of the foregoing it is an object of this invention to provide improved programmable logic array devices.

It is a more particular object of this invention to provide improved arrangements of interconnection resources on programmable logic array integrated circuits.

Summary of the Invention

These and other objects of the invention are accomplished in accordance with the principles of the invention by providing programmable logic array

5 integrated circuit devices having the traditional two-dimensional array of programmable logic regions with horizontal conductors associated with each row and vertical conductors associated with each column, but with the difference that some of the horizontal

10 conductors associated with each row extend continuously or substantially continuously along only approximately half the length of the row. Thus each row is divided into two mutually exclusive halves, with some "half-horizontal" conductors extending along each of the two

15 halves. In this way a half-horizontal conductor can be used to make connections to, from, and/or between logic regions in a half of the row without having to use a much longer than necessary full-horizontal conductor for this purpose. The full-horizontal conductors

20 (which extend continuously or substantially continuously along the entire length of a row, and which are sometimes also referred to as global horizontal conductors) can be saved for signals that must be transmitted beyond either half of the row.

25 Because two end-to-end half-horizontal conductors occupy the same space as one full-horizontal conductor, the provision of half-horizontal conductors makes more efficient use of the horizontal conductor real estate on the chip. In particular, the half-horizontal

30 conductors allow the number of full-horizontal conductors to be reduced. Reducing the number of horizontal conductors also helps reduce the size of the programmable switch arrays used to programmably connect the horizontal conductors to the inputs of each logic

35 region. Axially aligned and adjacent half-horizontal



conductors are preferably not directly connectable to one another. Thus there is preferably no possibility of programmably optionally piecing together axially aligned half-horizontal conductors to make longer horizontal conductors. Instead, that longer horizontal conductor resource is the global horizontal conductors, which are preferably continuous or substantially continuous and not made up of pieced-together shorter conductors.

Each logic region output signal is preferably programmably connectable to one full-horizontal conductor and one half-horizontal conductor. Each full- and half-horizontal conductor associated with a row is drivable by either of two outputs of logic regions in that row. Each logic region output is also programmably connectable to a vertical conductor. Having two logic region outputs share each full- and half-horizontal conductor also helps to reduce the number of horizontal conductors that must be provided. Again, this helps reduce the size of the programmable switch arrays used to programmably connect the horizontal conductors to the inputs of each logic region.

Both the half-horizontal and the full-horizontal conductors are programmably output-connectable to so-called "horizontal" input/output ("I/O") pins for purposes of outputting signals from the chip. For purposes of inputting to the chip, both the half-horizontal and the full-horizontal conductors could be programmably input-connectable to the horizontal I/O pins, but in the preferred embodiments only the full-horizontal conductors are thus programmably input-connectable.

Certain full-horizontal conductors (e.g., those that can receive inputs from the horizontal I/O

pins) are programmably connectable to drive certain vertical conductors. These vertical conductors are programmably connectable to drive other horizontal conductors in other rows. This gives the device the ability to route any horizontal input to any logic region in the device.

Each output of each logic region is programmably connectable to a half-horizontal conductor adjacent to the region, to a full-horizontal conductor adjacent to the region, and to two vertical conductors adjacent to the region. In addition, regions in adjacent columns are paired so that each output of each logic region in such a pair can alternatively use the output connections (to the above-mentioned half-horizontal, full-horizontal, and vertical conductors) of the corresponding output of the other region in the pair. This gives each output of a region two different sets of conductor destinations, thereby increasing interconnection flexibility without increasing the number of conductors that must be provided. Because these conductors are connectable to input/output ("I/O") pins of the device, the number of I/O pins that each logic region output can reach is also doubled.

In the preferred embodiments each logic region includes several logic modules. Each logic module has several input signals and is programmable to produce a combinational signal which is a desired logical combination of the inputs. Each logic module also includes a register (e.g., a flip-flop). The combinational signal can be passed to the output of the logic module either directly or via the register. To make a register usable, even when it is not being used to register the combinational signal of the logic module, programmable switches are provided for allowing one of the logic module inputs to be applied to the

register. Additional programmable switches are provided for allowing either the combinational signal (which is bypassing the register) or the register output signal to be applied to feedback circuits within the logic region. These additional switches also allow the signal which is not being applied to these feedback circuits to be applied to the above-mentioned conductors that go beyond the region. In other words, either the combinatorial or registered output signal can be used for either local feedback or region output. This is a greater degree of flexibility in the simultaneous use of a combinational signal and a so-called "lonely register" signal than is possible in the known prior devices.

Another feature that may be provided in accordance with this invention is an input-pin-driven global clear function for resetting all registers in the device.

Circuitry is added to each logic module and to I/O registers to make it possible to do clock enables more efficiently. A clock enable now requires only two logic module inputs, and dedicated clock enables are provided in the peripheral I/O cell logic.

The I/O cells are enhanced to include the following features: (1) an open drain option, (2) clock enables (mentioned above), (3) a pin-controlled global output enable, and (4) dedicated clocks. Each I/O cell also has dedicated output enable circuitry which is controlled directly from the horizontal conductors for horizontal I/O pins or from the vertical conductors for vertical I/O pins.

It is known to provide carry chain connections from one logic module to another in a logic region and from one logic region to another. Such carry chain connections facilitate the performance of

arithmetic functions such as adders and counters. In accordance with the present invention carry chain connections are not made between adjacent logic regions. Rather, the carry chain connection from each logic region skips the immediately adjacent logic region and goes to the next most nearly adjacent logic region. This spreads out an arithmetic chain to ease the fitting problems encountered, for example, by having a 16-bit counter all bunched together.

10 It is also known to provide cascade chain connections from one logic module to another in a logic region and from one logic region to another. Such cascade chain connections facilitate the performance of wide fan-in functions, for example. In accordance with this invention cascade chain connections are made in a similar fashion to carry chain connections. Thus cascade connections are not made between adjacent logic regions. Rather, the cascade connection from each logic region skips the immediately adjacent region and goes to the next most nearly adjacent logic region. This also eases fitting problems associated with wide fan-in functions.

25 So-called fast conductors are provided which extend to every logic region on the device. Such conductors are useful for purposes such as providing a global clock signal. To facilitate generation of a fast line signal by the device itself certain other conductors such as full-horizontal conductors are programmably connectable to the fast line conductors.

30 Further features of the invention, its nature and various advantages will be more apparent from the accompanying drawings and the following detailed description of the preferred embodiments.

Brief Description of the Drawings

FIG. 1 is a simplified, partial, schematic block diagram of an illustrative programmable logic array device that can be constructed in accordance with the principles of this invention.

FIG. 2 is a more detailed, but still simplified, schematic block diagram of a representative portion of the apparatus of FIG. 1.

FIG. 3 is a still more detailed, but still simplified, schematic block diagram of a representative portion of the apparatus of FIG. 1.

FIG. 4 is another more detailed, but still simplified, schematic block diagram of a representative portion of the apparatus of FIG. 1.

FIG. 5 is another more detailed, but still simplified, schematic block diagram of a representative portion of the apparatus of FIG. 1.

FIG. 6 is a simplified schematic block diagram of additional features of the apparatus of FIG. 1.

FIG. 7 is another more detailed, but still simplified, schematic block diagram of a representative portion of the apparatus of FIG. 1.

FIG. 8 is a more detailed, but still simplified, schematic block diagram of a portion of the circuitry shown in FIG. 3.

FIG. 9 is a more detailed, but still simplified, schematic block diagram of a portion of the circuitry shown in FIG. 5.

FIG. 10 is a more detailed, but still simplified, schematic block diagram of a portion of the circuitry shown in FIG. 6.

FIG. 11 is a simplified schematic block diagram showing other features of a representative portion of the circuitry shown in FIG. 1.

Detailed Description of the Preferred Embodiments

With reference to FIG. 1, illustrative programmable logic array integrated circuit device 10 has a plurality of regions 20 of programmable logic disposed on the device in a two-dimensional array of intersecting rows and columns of such regions. In the depicted preferred embodiment device 10 has ten rows of regions 20, 36 regular columns of regions 20, and two spare columns of regions 20. The spare columns (which are not shown in FIG. 1, but which are shown in part in FIG. 2) are used only when a regular column is found to be defective. The columns are divided into two groups: (1) 18 regular columns and one spare column to the left of a central column of random access memory ("RAM") regions 40, and (2) 18 regular columns and one spare column to the right of the central column of RAM regions 40. The spare column to the left of RAM regions 40 can only be used to compensate for a defective regular column to the left of regions 40. Similarly, the spare column to the right of RAM regions 40 can only be used to compensate for a defective regular column to the right of region 40.

Each region 20 includes a plurality of subregions or logic modules 30 of programmable logic. In the depicted preferred embodiment there are eight logic modules 30 in each region 20. To simplify FIG. 1 the subdivision of regions 20 into logic modules 30 is only shown in the first row of that FIG. Although logic modules 30 may be constructed in many other ways (e.g., as product-term-based macrocells), in the depicted preferred embodiment (see especially FIG. 3) each logic module includes a four-input look-up table or comparable universal logic block ("ULB") 32 and a flip-flop or register device 34. Each ULB 32 can be

independently programmed to provide as an output signal any logical combination of four inputs 36 to the logic module 30 that includes that ULB. The output signal of the ULB can be registered by the associated flip-flop 5 34 and then made the output signal 38 of the logic module, or the output signal of the ULB can be applied directly to output 38 (i.e., without registration by the flip-flop). Each logic module 30 also has a cascade input 52 and a carry-in input 54 from an 10 adjacent logic module, as well as a cascade output 52 and a carry-out output 54 to another adjacent logic module. These inputs 52/54 can be combined with or substituted for regular inputs 36 to facilitate provision of large fan-in functions or the performance 15 of adder and counter functions. Suitable cascade circuitry is shown in more detail in Cliff et al. U.S. patent 5,258,668. Suitable carry circuitry is shown in more detail in Cliff et al. U.S. patent 5,274,581. (The cascade connection 52t from the row above is a 20 special connection used for test purposes and is not germane to the present invention.)

Returning to FIG. 1, each row has two groups of horizontal interconnection conductors 60 that extend the entire length of the row, one group of conductors 25 60 being above the row and the other group being below the row. In the depicted preferred embodiment each of these groups includes 72 conductors. (In some other views, such as FIGS. 2 and 3, all of conductors 60 associated with a row are shown on one side of the row 30 for greater simplicity.) Conductors 60 are sometimes referred to as full-horizontal conductors or as global horizontal conductors. Each conductor 60 preferably extends continuously or substantially continuously along the entire length of the associated row and is

not made up of shorter conductor segments that are optionally programmably pieced together.

Each row also has four groups of horizontal interconnection conductors 70 that extend along half  
5 the length of the row. Two of these groups extend respectively along the top and bottom of the left half of the row. The other two groups of these conductors 70 extend respectively along the top and bottom of the right half of the row. In the depicted preferred  
10 embodiment each of these groups includes 36 conductors. (Again, in some other FIGS. all of the conductors 70 associated with the left or right half of a row are shown on one side of the row for greater simplicity.) The conductors 70 associated with each half of a row  
15 are preferably not directly connectable to the conductors 70 associated with the other half of the row. This characteristic of conductors 70 is sometimes referred to herein by saying that each conductor 70 is "separate" from all other conductors 70. Conductors 70  
20 are sometimes referred to as half-horizontal conductors. Each conductor 70 preferably extends continuously or substantially continuously along the length of the associated half row and is not made up of shorter conductor segments that are optionally  
25 programmably pieced together.

Each column of regular logic regions 20 has a group of vertical interconnection conductors 80 that extend continuously or substantially continuously along the entire length of the column. In the depicted  
30 preferred embodiment each of these groups includes 24 conductors 80.

In order to feed logic signals to each region 20, each regular logic region has an associated plurality of region feeding conductors 90 that can  
35 bring signals to the logic region from the horizontal



conductors 60 and 70 associated with that region. In the depicted preferred embodiment there are 22 region feeding conductors 90 associated with each regular logic region 20. The manner in which conductors 90 are programmably connectable to conductors 60, 70, and 36 (FIG. 3) will be discussed in detail below.

Each region 20 also has eight associated local feedback conductors 100. Each conductor 100 makes the output signal 38 (FIG. 3) of a respective one of the logic modules 30 in the associated region 20 available as an input to any of the logic modules in that region without having to use any interconnection resources that are not exclusively associated with the region.

Each region 20 also has output conductors 120 for conveying the output logic signals 38 (FIG. 3) of the logic modules 30 in that region to the associated conductors 60 and 70. Conductors 120 convey the output signals of the upper four logic modules 30 in a region 20 to the conductors 60 and 70 that are above the region. Other conductors 120 associated with the region convey the output signals of the lower four logic modules 30 in the region to the conductors 60 and 70 that are below the region. The manner in which conductors 120 are programmably connectable to conductors 60 and 70 is discussed in more detail below. The output signals 38 (FIG. 3) of each regular logic region 20 are also programmably connectable to the vertical conductors 80 associated with that region. This will also be discussed in more detail below.

Programmable logic connectors ("PLCs") (not shown in FIG. 1 but shown elsewhere such as at 242 in FIG. 3) are associated with each regular logic region 20 for making connections from the vertical (80) to the horizontal (60 and 70) conductors associated with the

region. Other PLCs (not shown in FIG. 1 but shown elsewhere such as at 270 in FIG. 4) are associated with each regular logic region 20 for making connections from the horizontal (60) to the vertical (80)

5 conductors associated with the region.

PLCs 242 and 270 (and other PLCs used throughout device 10) can be implemented in any of a wide variety of ways. For example, each PLC can be a relatively simple programmable connector such as a  
10 switch or a plurality of switches for connecting any one of several inputs to an output. Alternatively, each PLC can be a somewhat more complex element which is capable of performing logic (e.g., by logically combining several of its inputs) as well as making a  
15 connection. In the latter case, for example, each PLC can be product term logic, implementing functions such as AND, NAND, OR, or NOR. Example of components suitable for implementing PLCs are EPROMs, EEPROMs, pass transistors, transmission gates, antifuses, laser  
20 fuses, metal optional links, etc. The components of PLCs can be controlled by various, programmable, function control elements ("FCEs"), which are not always shown separately in the accompanying drawings. (With certain PLC implementations (e.g., fuses and  
25 metal optional links) separate FCE devices are not required, so that in those cases any depiction of FCE devices in the accompanying drawings merely indicates that the PLCs are programmable.) FCEs can also be implemented in any of several different ways. For  
30 example, FCEs can be SRAMs, DRAMs, first-in first-out ("FIFO") memories, EPROMs, EEPROMs, function control registers (e.g., as in Wahlstrom U.S. patent 3,473,160), ferro-electric memories, fuses, antifuses, or the like. Any of these technologies can also be  
35 used to implement the programmable memories of above-

described ULBs 32. From the various examples mentioned above it will be seen that this invention is applicable both to one-time-only programmable and reprogrammable devices. However, for at least some features of the invention, the especially preferred embodiments tend to be reprogrammable because reprogrammable devices tend to benefit more from the economies of interconnection resources that result from the practice of this invention.

10                   At each end of each row there are eight "horizontal" input/output pins 130. The input/output pins 130 associated with each end of each row are programmably connectable to the adjacent conductors 60 and 70 associated with that row via PLC networks 140. 15 The construction of networks 140 is discussed in more detail below.

                  At the top and bottom of each column of regular logic regions 20 there are two "vertical" input/output pins 150. The input/output pins 150 20 associated with each end of each column are programmably connectable to the conductors 80 associated with that column via PLC networks 160. Networks 160 can be generally similar to networks 140.

                  As has been mentioned, at the center of each 25 row, there is a region of RAM 40 that is programmable and usable by the user to store and output any desired data. Each RAM region 40 can receive data via a plurality of RAM feeding conductors 90'. In the depicted preferred embodiment there are 22 conductors 30 90' associated with each RAM region 40. Conductors 90' can receive signals from the conductors 60 and from the left half of the conductors 70 associated with the row that includes the RAM region served by those conductors 90'. The manner in which conductors 90' are

programmably connectable to conductors 60 and 70 is discussed in more detail below.

Each RAM region 40 can output its data to an associated plurality of RAM output conductors 120' and also to a plurality of vertical interconnection conductors 80' that extend along the length of the column of RAM regions. Conductors 120' can be used to apply the associated RAM output signals to the conductors 60 associated with the row that includes the RAM region 40 producing those output signals. Conductors 80' can be used to convey the RAM output signals to other rows of the device. In the depicted preferred embodiments there are 24 conductors 80'.

Each RAM region 40 also includes PLCs (not shown in FIG. 1 but shown at 454 in FIG. 7) that can be used to connect conductors 80' to the conductors 60 associated with the row that includes that RAM region.

It will be apparent from the ensuing discussion that device 10 includes more circuitry than is shown in FIG. 1. For example, FIG. 6 shows that there are four so-called fast lines 170 that extend from four dedicated input pins 180 to the vicinity of every region 20 (see also FIGS. 2 and 3). FIG. 6 also shows that the device is ringed by a so-called peripheral bus that includes two clock signal conductors 190 (extending from two dedicated clock input terminals 200), six output enable signal conductors 210, and six clock enable signal conductors 212. FIGS. 2 and 3 show that the two clock signal conductors 190 (like fast conductors 170) extend to the vicinity of every region 20 on the device.

FIG. 2 illustrates some of the connections of a typical row in somewhat more detail than FIG. 1. It will be understood, however, that FIG. 2 tends to show only a few representative conductors of each type, or

in some cases represents several conductors by a single line. FIG. 2 also shows the two spare logic regions (designated 20s) in a typical row.

FIG. 2 shows that there are several  
5 programmable connections 62 from the conductors 60 associated with each row to the conductors 80 associated with each column. In the depicted preferred embodiment there are four such programmable connections 62 from each row to each column. The connections 62  
10 along each row are distributed over the conductors 60 associated with that row. Similarly, the connections 62 along each column are distributed over the conductors 80 associated with that column.

FIG. 2 also shows that there are programmable  
15 connections 82 from the conductors 80 associated with each column to the conductors 60 associated with each row, as well as programmable connections 84 from the conductors 80 associated with each column to the conductors 70 associated with each row. The  
20 connections 82 and 84 along each column are distributed over the conductors 80 associated with that column. Similarly, the connections 82 and 84 along each row are respectively distributed over the conductors 60 and 70 associated with that row.

FIG. 2 further shows that each logic module  
25 30 in each region 20 in a row can drive one conductor 60 and one conductor 70 associated with the row that includes that region. This is done via programmable connections 120, which are, of course, also shown in  
30 FIG. 1 and partly described above. FIG. 2 shows that the connections 120 along a row are distributed over the conductors 60 and 70 associated with that row.

FIG. 2 still further shows that the left half  
of the conductors 70 associated with a row can supply  
35 inputs to the RAM region 40 associated with that row.

(The conductors 60 associated with a row can also supply inputs to the RAM region 40 associated with that row, but this is better shown in FIG. 7.) Outputs of a RAM region can be applied to certain of the associated  
5 conductors 60 via programmable connections 120'. There are programmable connections 82' from conductors 80' associated with the RAM column to the conductors 60 associated with each row.

FIG. 2 also shows the availability of the  
10 four fast conductors 170 and the two dedicated clock conductors 190 adjacent each region 20 in a row.

FIG. 3 shows various aspects of a representative region 20 and associated apparatus in more detail. Each of the 22 region feeding conductors  
15 90 associated with a region receives the output of a PLC 64 (a 21 to 1 multiplexer in the depicted, presently preferred embodiment) associated with that conductor 90. The 21 inputs to each PLC 64 associated with a region are different subsets of fast conductors  
20 170, dedicated clock conductors 190, the conductors 60 associated with the row that includes the region, and the conductors 70 associated with the half row that includes the region. Thus the inputs to each PLC 64 are a partial population of the conductors 60, 70, 170,  
25 and 190 associated with the region. As a multiplexer, each of PLCs 64 is programmable to connect any one of its inputs to its output. This is similarly true of the other multiplexers mentioned throughout this specification.

30 The main output logic signal 38 of each logic module 30 in a region 20 is applied (via a feedback buffer 200) to a respective one of the local feedback conductors 100 associated with that region. As was mentioned in connection with FIG. 1, local feedback  
35 conductors 100 are associated with each region 20 to

make the output of each logic module 30 in the region available as a possible input to any logic module in the region without having to use any of the more general interconnection resources of the chip to  
5 provide such local interconnectivity.

The signal on any of conductors 90 or 100 associated with a region 20 can be applied to any of the main inputs 36 of any logic module 30 in that region via a PLC 92 (a 30 to 1 multiplexer in the  
10 depicted, presently preferred embodiment) that is associated with that input 36. Thus the inputs to each PLC 92 are a full population of associated conductors 90 and 100.

Each logic module 30 in a region 20 can also  
15 receive any of several control signals via leads 220. The signals on these leads may be used by the logic module for such purposes as a clock signal for the flip-flop 34 of the logic module and/or a clear signal for the flip-flop of the logic module. Circles 172 in  
20 FIG. 3 represent fully populated PLCs for selectively bringing the signals on fast conductors 170 and dedicated clock conductors 190 into the region via leads 174 for possible use on leads 220 in that region. Certain of leads 174 can alternatively carry so-called  
25 asynchronous clock and/or clear signals derived from the conductors 90 and/or 100 associated with the region. PLCs 94 (similar in all respects to above-described PLCs 92) are provided to connect any of conductors 90 and 100 to selected leads 174 to make  
30 these asynchronous clock and/or clear signals available. Although two PLCs 94 are shown in FIG. 3, a larger number (such as four) is preferred.

The signals on leads 174 are applied to programmable inversion and buffering circuitry 230.  
35 This circuit buffers each applied signal, and may also

invert any applied signal under programmable control. The output signals of circuit 230 are made available to each logic module 30 in the region via conductors 212.

The main output logic signal 38 of each logic  
5 module 30 in a region 20 can be applied (via  
programmably controlled tri-state drivers 240 and leads  
241) to either or both of two conductors 80 associated  
with the column that includes that region. The output  
signal 38 of each logic module in a region can  
10 alternatively or additionally be applied (via PLCs 242  
(multiplexers in the presently preferred embodiment)  
and programmably controlled tri-state drivers 244) to  
one of conductors 60 and/or to one of conductors 70  
associated with that region. The other inputs to each  
15 of PLCs 242 (i.e., on the leads designated 82 or 84 in  
FIG. 3) are signals from several of the conductors 80  
associated with the region. Thus any of PLCs 242 and  
drivers 244 can alternatively be used to apply a signal  
on a conductor 80 to a conductor 60 or 70 associated  
20 with the region. The inputs 82/84 from conductors 80  
to PLCs 242 are distributed over conductors 80.  
Similarly, the outputs from drivers 240 are distributed  
over conductors 80, and the outputs from drivers 244  
are distributed over conductors 60 and 70.

25 For simplicity FIGS. 1-3 all assume that the  
regions 20 in each column are uniquely associated with  
the conductors 80 adjacent to that column and with the  
elements 240, 242, and 244 adjacent to the regions in  
that column. In the preferred embodiment, however, the  
30 outputs 38 of the logic modules in each column can in  
fact be shifted to an adjacent column, if desired, for  
either of two distinct purposes. The first of these  
purposes is to use a spare column of regions 20s to  
make up for a defect in another regular column. The  
35 second of these purposes is to swap the outputs of two



adjacent columns to increase the flexibility with which outputs 38 can be introduced to conductors 60, 70, and 80. Representative circuitry for performing these two different kinds of column shifts of logic module

5 outputs is shown in FIG. 4.

FIG. 4 shows one representative logic module 30 from each of two adjacent columns. These two logic modules are therefore horizontally adjacent to one another. The output 38 from the left-hand logic module 10 is applied to one input of the redundancy PLC 250 (a multiplexer in the presently preferred embodiment) in the associated column, and also to one input of the similar redundancy PLC 250 in the column to the right. The other input to the PLC 250 in the left-hand column 15 is a similar logic module output 38 from the column to the left of the columns shown in FIG. 4. The other input to the PLC 250 in the right-hand column is the output 38 from the depicted logic module in that column, and that logic module output is also applied to 20 one input of the PLC 250 in the column to the right of the depicted columns. Each of PLCs 250 is controlled (via the associated control lead 251) by an associated FCE (a fuse in the presently preferred embodiment). PLCs 250 are controlled so that the logic module 25 outputs 38 of a column containing a defect can be replaced by the outputs 38 of the column to the left of the defective column. The outputs of all columns to the left of a defective column are shifted right one column, and the spare column to the left of a defective 30 column is put to use to make up for loss of the defective column. These column shifts are, however, confined to each of the two halves (left/right) of the device. In other words, there is no shifting from one side of the column of RAM regions 40 to the other side 35 of that column.

The output of the redundancy PLCs 250 in the left-hand column in FIG. 4 is applied to one input terminal of the programmable swap PLC 260 (a multiplexer in the presently preferred embodiment) in that column and to one input terminal of the similar swap PLC 260 in the column to the right. The output of the redundancy PLC 250 in the right-hand column in FIG. 4 is applied to the other input terminal of the swap PLC 260 in the right-hand column, as well as to the other input terminal of the swap PLC 260 in the left-hand column. PLCs 260 are controlled via leads 261 by FCEs on device 10. It will therefore be apparent that the PLCs 260 in two adjacent columns that are paired by cross-connected PLC 250 outputs as shown in FIG. 4 allow the logic module outputs of those two columns to be swapped if desired. In particular, because the outputs of drivers 244 in the left-hand column in FIG. 4 are connected to different conductors 60 and 70 than the outputs of drivers 244 in the right-hand column, swap PLCs 260 double the choices available for connection of each logic module output signal 38 to conductors 60 and 70. Similarly, because the outputs of drivers 240 in the left-hand column in FIG. 4 are connected to different conductors 80 than drivers 240 in the right-hand column, swap PLCs 260 also double the choices available for connection of each logic module output signal 38 to conductors 80.

As a possible alternative to swap PLCs 260 in directly horizontally adjacent logic modules being paired as shown in FIG. 4, more mixing can be built into the swap PLC logic by having each swap PLC receive its second input from a first other logic module, while the primary input to that swap PLC is also directed (as a second input) to the swap PLC in a second other logic module. All of the swap PLC exchanges in this

alternative are preferably between logic modules in horizontally adjacent blocks, but they are not all between directly horizontally adjacent logic modules.

It will be understood from FIG. 4 that although PLCs 250 and 260 are not shown in FIG. 3, they are in fact interposed between the logic module outputs 38 and elements 240 and 242 in FIG. 3.

FIG. 4 also shows more detail as to how connections 62 in FIG. 2 are implemented. Four of the eight logic modules 30 in each region 20 have an associated PLC 270 (a multiplexer in the presently preferred embodiment) as shown in FIG. 4. Thus there are four PLCs 270 associated with each region 20. Each PLC 270 allows either a logic module output signal 120 or the signal 62 on one of adjacent conductors 60 to be applied to the associated driver 240 and thereby to one of associated conductors 80.

FIG. 5 shows some additional aspects of the connections to and from the conductors 60 and 70 for a typical row. As mentioned in connection with FIG. 1, each row has eight associated input/output pins 130 adjacent each end of the row. Also there are 144 conductors 60 and 72 conductors 70, for a total of 216 conductors 60/70 at each end of each row. (Each conductor 60, of course, appears at both ends of the associated row. Thus each conductor 60 is connectable to a pin 130 at either end of its row.) The conductors 60/70 at each end of a row are divided into eight different groups of 27 conductors each, and the conductors in each such group are applied to the 27 inputs of a respective one of PLCs 280 (27 to 1 multiplexers in the presently preferred embodiment). Each PLC 280 can select one of its inputs for application to an associated input/output pin 130 when that pin is to be used as a chip output.

For use of pins 130 as chip inputs, the signal on each pin 130 is applied to the inputs of two associated, programmable, tri-state drivers 132, the outputs of which are applied to different ones of  
5 conductors 60 in the row associated with that pin 130.

FIG. 5 also shows again that in each row half of the conductors 60 and 70 are above the logic regions 20 of that row, and the other half of conductors 60 and 70 are below those logic regions. And, as FIG. 5  
10 shows, the upper four logic modules 30 in each region in a row supply their output signals 38 or 120 to the conductors 60/70 that are above the row, while the lower four logic modules in each region supply their output signals 38 or 120 to the conductors 60/70 that  
15 are below the row.

FIG. 6 has already been partly considered but will now be more fully discussed. As has been mentioned, there is a so-called peripheral bus that extends in a closed loop around the periphery of device  
20 10. This peripheral bus includes the two dedicated clock signal conductors 190, six output enable conductors 210 (numbered 0 through 5, respectively), and six clock enable conductors 212 (numbered 0 through 5, respectively). Conductors 210 and 212 can be driven  
25 by the conductors 60 associated with each row that are drivable by the top-most logic module 30 in each region 20 in that row. Numbering the rows 0 through 9 from top to bottom, the following table shows the peripheral bus signals that are derivable from each row  
30 (where OE stands for output enable and CLKENB stands for clock enable):

TABLE 1

	<u>Row Number</u>	<u>Peripheral Bus Signal(s)</u>
	0	OE0 CLKENB0
5	1	OE1
	2	CLKENB1
	3	OE2
	4	CLKENB2
	5	OE3
10	6	CLKENB3
	7	OE4
	8	CLKENB4
	9	CLKENB5 OE5

15           FIG. 6 shows the circuitry associated with representative rows for deriving the output enable and clock enable signals as in the foregoing table. This circuitry is exactly duplicated at both ends of each row to reduce signal propagation delay to and on the peripheral bus. Only one end of each row needs to be actually considered in connection with the following discussion.

          Considering first the top-most row (row 0 in Table 1), the 18 conductors 60 that can receive output signals from the top logic module 30 of each region in the row are applied to PLCs 290 and 292 (22 to 1 multiplexers in the presently preferred embodiment) associated with that row. The four fast conductors 170 are also applied to those PLCs. PLCs 290 select one of their inputs as the OE0 signal and apply that signal (via drivers 294) to OE0 peripheral bus conductor 210. PLCs 292 similarly select one of their inputs as the CLKENB0 signal and apply that signal (via drivers 296) to the CLKENB0 peripheral bus conductor 212.

35           In the second row the 18 conductors 60 that can receive the output signal of the top-most logic module 30 of each region in the row are connected to PLCs 290. The four fast conductors 170 are also connected to those PLCs. PLCs 290 select one of the

applied signals for application (via drivers 294) to the OE1 peripheral bus conductor 210.

The next to last row shown in FIG. 6 is row 8. The PLCs 292 in that row receive the 18 conductors 60 that can carry the top-most logic module output signals of that row and the four fast conductors 170. PLCs 292 select one of these inputs as the CLKENB4 signal, which is applied via drivers 296 to the appropriate peripheral bus conductor 212.

10 The bottom row shown in FIG. 6 is row 9. It is similar to the top row (row 0), except that the output of PLCs 290 is the OE5 signal and the output of PLCs 292 is the CLKENB5 signal.

FIG. 6 also shows how the various peripheral bus signals are used in input/output cells associated with input/output pins 130 and 150. Representative circuitry 300 for generating an output enable signal, a clock signal, a clock enable signal, and a clear signal used in an input/output cell associated with an input/output pin 130 or 150 is shown in FIG. 6. (Each input/output pin 130 and 150 has an associated input/output cell 600, a representative one of which is shown in FIG. 9 and described in detail below. Each input/output cell 600 has associated circuitry 300 as shown in FIG. 6 (and repeated in FIG. 9).) PLC 302 (a 9 to 1 multiplexer in the presently preferred embodiment) receives the six output enable signals from conductors 210, one signal from a conductor 60 or 70 from the row associated with the pin 130 served by that circuitry 300 (or from a conductor 80 from the column associated with the pin 150 served by that circuitry 300), and the CLKENB0 and CLKENB1 signals from conductors 212. PLC 302 selects one of these nine inputs as the output enable signal of the associated input/output cell 600. Because one of the inputs to

each PLC 302 is a conductor 60, 70, or 80 associated with the row or column that the associated input/output pin 130 or 150 is associated with, each input/output pin 130 and 150 can have its own unique output enable signal. PLC 304 (a 4 to 1 multiplexer in the presently preferred embodiment) receives the CLK0 and CLK1 signals from conductors 190, and the CKLENB0 and CLKENB5 signals from conductors 212. PLC 304 selects one of these signals as the clock signal of circuitry 300. PLC 306 (a 7 to 1 multiplexer in the presently preferred embodiment) receives the six clock enable signals from conductors 212 and one signal from a conductor 60/70 or a conductor 80, depending on whether circuitry 300 serves a pin 130 or a pin 150. PLC 306 can select one of its inputs as the clock enable signal of circuitry 300. Again, because one of the inputs to each PLC 306 is a conductor 60, 70, or 80 associated with the row or column that the associated input/output pin 130 or 150 is associated with, each input/output pin 130 and 150 can have its own unique clock enable signal. Lastly, PLC 308 (a 2 to 1 multiplexer in the presently preferred embodiment) receives the CLKENB2 and CLKENB4 signals from conductors 212, and can select either of these two signals as the clear signal of circuitry 300.

FIG. 7 shows a typical RAM region 40 in more detail, there being one such RAM region associated with each row. Each RAM region 40 includes 2048 bits of random access memory. These RAM bits are organized in a 64x32 array 400, which can be reconfigured as a 256x8, 512x4, 1024x2, or 2048x1 memory. Array 400 can be used as a static random access memory (SRAM) or as a read-only memory (ROM). Each memory cell (which can be implemented as described above for FCEs) can be accessed through a row decoder 410 and a column decoder

420. The RAM region 40 needs a maximum of 11 address signals, eight data signals, a read-write control signal, two clock signals, and an output enable signal in order to operate.

5                   The interface of RAM region 40 to the remainder of the chip is very similar to the interface for a regular logic region 20. RAM region 40 has 22 region feeding conductors 90' for bringing signals into the region from the row conductors 60 associated with  
10 the row that includes the RAM region and also from the half-row conductors 70 associated with left half of that row. Each of these conductors 60 and 70 has four chances to route into the RAM region via PLCs 64' (as compared to two chances in a regular logic region 20).  
15 PLCs 64' also allow fast conductors 170 and dedicated clock conductors 190 to feed conductors 90'. The input PLCs 92' to the RAM region are fully populated. The clock and read-write control signals (applied to programmable clock and read-write control circuit 442)  
20 can be generated either from the conductors 90' or more directly from conductors 170 and 190 via PLCs 64". Control circuit 442 makes this selection, and is also programmable to invert any of the selected signals. The read-write control signal output by circuit 442 is  
25 applied to read/write control block 448 via register/bypass circuit 441. Circuit 441 is programmable to either register the read-write control signal or to pass that signal through without registration. The "input" clock signal output by  
30 circuit 442 is applied to the clock input terminals of registers 430, 440a, 440b, 441, and 448. The "output" clock signal output by circuit 442 is applied to register 450. The "output" clock signal can be the same as the "input" clock signal, or it can be  
35 independent of the "input" clock signal. The output



enable signal is applied to tri-state control logic elements 446 via register/bypass circuit 444 to possibly control elements 446 as is more fully described below. Circuit 444 is programmable to either register the output enable signal or to pass that signal through without registration.

RAM region 40 can be programmed to operate either in synchronous or asynchronous mode. In synchronous mode all data lines, address lines, and RAM outputs are registered by data register 430, address registers 440a/b, and RAM output register 450, respectively. Thus each of registers 430, 440a, 440b, and 450 is programmable to either register the applied signals or to pass those signals through unregistered.

Register 430 receives as many as eight data signals from associated PLCs 92'. The data output signals of register 430 are buffered by buffers 432 and applied to column decoder and data selection and control logic 420. Control logic 420 also receives via leads 422 the outputs of four FCEs which control whether RAM region 40 will function as an eight-bit-wide, four-bit wide, two-bit-wide, or one-bit-wide memory. (These four signals 422 are also applied to RAM data output selection circuit 404.) Control logic 420 also receives a programming mode control signal via lead 406, and the five most significant address bits from register 440b. (For use during programming mode operation of the device, control logic 420 also receives 32 programming data input signals via leads 470a as will be described in more detail below.) Control logic 420 produces on leads 424 address signals and on leads 426 data signals appropriate to the storage in RAM array 400 of one, two, four, or eight bits of data, depending on the memory configuration selected by the signals on leads 422.

Register 440a receives the six least significant address bits from associated PLCs 92'. The output signals of register 440a are applied to address control block 464. Control block 464 also receives six  
5 output signals from preload down counter 462, which is usable during programming mode to supply sequential RAM addresses to facilitate storage in the RAM of data that will subsequently be ROM data. Control block 464 selects one of the two groups of six inputs it  
10 receives, depending on whether the device is in programming mode as indicated by the signal on above-mentioned lead 406. The six outputs of control block 464 are applied to row decoder 410, which produces one of 64 outputs applied to address multiplexing circuit  
15 402. Circuit 402 makes a one-of-64 selection to select one of the 64 rows of RAM array 400 that is to receive or output data.

Register 440b receives the five most significant address bits from associated PLCs 92'. As  
20 has been mentioned, the five address bits received by register 440b are applied to column decoder and data selection and control logic 420 for use in selecting the column or columns in RAM array 400 that is or are to receive or output data. The write enable signal is  
25 applied from register/bypass circuit 441 to programmable read/write control block 448, which produces read enable and write enable signals that are applied to address multiplexing circuit 402. Circuit 402 applies to RAM array 400 one of 64 read address  
30 signals 403a or one of 64 write address signals 403b, depending on whether reading or writing is enabled.

As has been said, RAM region 40 has 11 address lines, eight data lines, a read-write control line, two clock lines, and an output enable line. RAM  
35 array 400 can be configured as a 2Kx1, 1Kx2, 512x4, or

256x8 memory. There are four FCEs 422 to control these different configurations. The following table lists the address lines and data lines required under the four conditions identified above:

5

TABLE 2

	<u>2Kx1</u>	<u>1Kx2</u>	<u>512x4</u>	<u>256x8</u>
Address lines:	11	10	9	8
Data lines:	1	2	4	8
Read-Write				
10 Control:	1	1	1	1
Clocks and Output				
Enable:	<u>3</u>	<u>3</u>	<u>3</u>	<u>3</u>
Total:	16	16	17	20

15 If the "by 8" mode is selected (right-most column in Table 2), the three most significant address lines are automatically tied high. If the "by 4" mode is selected (next-to-right-most column in Table 2), the two most significant address lines are automatically tied high. If the "by 2" mode is selected (next-to-  
20 left-most column in Table 2), the most significant address line is automatically tied high.

RAM data output selection circuit 404 has 32 inputs, one from each column of RAM array 400. Circuit 404 also receives the four control inputs 422 described  
25 above. During normal operation of the device (as distinguished from programming mode operation) circuit 404 applies the data it receives from RAM array 400 to RAM output register 450 in a format determined by  
30 inputs 422 (i.e., a one-bit, two-bit, four-bit, or eight-bit format). Register 450 outputs the data it receives in the same format. (During programming mode operation circuit 404 simply passes its 32 inputs through to its 32 outputs 470b.)

To increase the depth or width of the RAM  
35 memory, the RAM regions 40 in two or more rows can be cascaded together. For example, to provide a 2Kx8 memory, eight 2Kx1 blocks can be used in parallel.

This means using the RAM regions 40 in eight rows. Each row would contain a one-bit slice or byte of the eight-bit word, and the data from the eight rows would collectively provide the eight-bit word.

5 Alternatively, a 256x8 configuration can be chosen for each of eight rows. Each row would produce an eight-bit byte or word which could be multiplexed with eight-bit bytes or words from the other rows. The multiplexing would be done in logic regions 20, and the high order RAM region address bits would control the multiplexing. Using all ten rows of RAM regions 40, the maximum memory depth possible is 20K (in a 20Kx1 memory), and the maximum width possible is 80 bits (in a 256x80 memory). The following table lists some of the possible combinations with the different building blocks:

TABLE 3

	2Kx1 as building block:
20	2Kx1, 2Kx2, 2Kx3, ..., or 2Kx10; 4Kx1, 6Kx1, 8Kx1, ..., or 20Kx1
	1Kx2 as building block:
	1Kx2, 1Kx4, 1Kx6, ..., or 1Kx20; 2Kx2, 3Kx2, 4Kx2, ..., or 10Kx2;
	512x4 as building block:
25	512x4, 512x8, 512x12, ..., or 512x40; 1Kx4, 1.5Kx4, 2Kx4, ..., or 5Kx4
	256x8 as building block:
	256x8, 256x16, 256x24, ..., or 256x80; 512x8, 768x8, 1Kx8, ..., or 2.5Kx8

30 Returning to the discussion of synchronous vs. asynchronous mode, the selection of synchronous mode is controlled by the read-write control signal. If the read-write control signal is registered by circuit 441, then the RAM region is in synchronous mode. In synchronous mode the RAM region supports multiple read/write with continuous clock. For write

35

operation the read-write control signal is held low, a new address is decoded during "input" clock high time (from circuit 442), and data is written into the RAM cells during the "input" clock low time. For read  
5 operation, the read-write control signal is held high, the data is read out on the rising edge of the "output" clock signal (from circuit 442) if the output is registered, or the data is read out directly if the output is bypassed. Thus, like registers 430, 440, and  
10 other similar elements, register 450 has selectable bypass capability.

In asynchronous mode the read-write control register 441 is bypassed and the "input" clock from circuit 442 is not used. The writing and reading of  
15 data into the RAM cells is controlled purely by the read-write control signal. During the write cycle the read-write control signal is held low and the RAM cells addressed will be written. The address signals are not allowed to change when the read-write control signal is  
20 low. During the read cycle, the read-write control signal is held high and the contents of the RAM cell addressed is read out. The address signals can be changed only when the read-write control signal is high.

25 As has been mentioned, RAM regions 40 can be operated as either an SRAM array which can be written to and read from dynamically, or as a ROM array with read-only access. Each RAM cell can be accessed through row decoder 410 and column decoder 420. Row  
30 decoder 410 takes the six least significant address bits from 11 address bits, and column decoder 420 takes the five most significant bits from the 11 address bits. To write data into the RAM cell synchronously the read-write control signal is held low and on the  
35 falling edge clock the data will be written into the

addressed RAM cell. To read data out of the RAM cell  
synchronously the read-write control signal is held  
high and on the rising edge of the clock the data is  
read out of the addressed RAM cell. In asynchronous  
5 mode read-write control signal register 441 is  
bypassed. The writing and reading of data into the RAM  
cells is controlled by the read-write control signal  
only. When the read-write control signal is low, the  
location addressed by the address lines is written to.  
10 Data is read out of the addressed locations when the  
read-write control signal is held high.

To use the RAM regions as a ROM, data is  
written into the memory cells during programming of the  
chip. During programming, six-bit preload down counter  
15 462 counts down sequentially from 3F (hexadecimal) to  
00 (hexadecimal). The six outputs of counter 462 are  
fed to row decoder 410 to generate the row address  
while all column decoder 420 outputs are held high so  
that the 64x32 array 400 is programmed like a first-  
20 in-first-out (FIFO) chain. The programming data is  
supplied via 32 programming data leads 470a which come  
from the RAM region 40 of the preceding row. The chain  
of programming data leads continues via leads 470b to  
the RAM region 40 in the next row. After programming,  
25 the RAM regions act like a ROM if the read-write  
control signal is held permanently high to force the  
memory into read mode only.

There are 24 vertical conductors 80'  
associated with the column of RAM regions 40. Each RAM  
30 region 40 has 16 tri-state drivers 452 for selectively  
driving various ones of these vertical conductors 80'.  
Thus each RAM region output (from register 450) can  
drive either or both of two of vertical conductors 80'.  
Each driver 452 is controlled by associated tri-state  
35 control logic 446. Each of circuits 446 is controlled

in turn by the user tri-state output enable signal from element 444 and two other programmable bits. Each driver 452 has three states: always on, always off, and tri-state. The user tri-state control has been  
5 provided as a means of having multiple blocks of RAM driving the same set of conductors 80'. This can be used for building "ping-ponging" type RAM, where one block outputs its data and then is switched off so another block can be switched on and output its data  
10 onto the same conductors 80'.

There are also 16 programmable tri-state drivers 456 associated with each RAM region 40 for selectively applying the RAM output signals to the horizontal conductors 60 associated with the row that  
15 includes that RAM region. Thus each RAM output can be applied to either or both of two conductors 60. (These are the programmable connections identified as 120' in other FIGS. such as FIG. 2.) Each driver 456 can alternatively be used to apply the signal on any of  
20 three conductors 80' to the conductor 60 driven by that driver. (These are the programmable connections identified as 82' in other FIGS. such as FIG. 2.) PLCs 454 (multiplexers in the presently preferred embodiment) select which signal the associated driver  
25 456 will apply to the driven conductor 60.

FIG. 8 shows an illustrative logic module 30 in more detail. The four primary inputs 36 to the logic module are respectively designated A-D. Input A is applied to one input terminal of each of PLCs 502a  
30 and 502b, as well as to a control input terminal of PLC 532. PLC 532 can be enabled to respond to input A by suitably programming FCE 534. If FCE 534 is not programmed to cause PLC 532 to respond to input A, then PLC 532 always applies the output signal of PLC 530 to  
35 the D data input terminal of flip-flop or register

circuit 34. On the other hand, if FCE 534 is programmed to cause PLC 532 to respond to input A, then the state of input A determines whether PLC 532 connects the output of PLC 530 or the Q output of flip-flop 34 to the D input terminal of the flip-flop. If the output of the flip-flop is connected to its D input terminal, the flip-flop is rendered unable to take in any new data in response to clock pulses applied to its clock input terminal 536. Input A can thereby be made to be a clock enable signal for logic module register 34.

Returning to PLCs 502a and 502b, the other input to PLC 502a is the Q output of flip-flop 34. This circuit path is useful when the logic module is to be used as a counter stage. This (and several other attributes of logic module 30 which were known before) is explained in more detail, for example, in Cliff et al. U.S. patents 5,258,668 and 5,274,581. Input B is applied to the other input to PLC 502b. Input C is applied to one input of PLC 502c, and also to the "Data" input terminal of flip-flop 34. This latter circuit path can be used to load data directly into flip-flop 34, for example, when logic module 30 is part of a loadable counter.

Input D is applied to ULB 32, and is also applied to one input of PLC 530. The other input to PLC 530 is the output of cascade connect circuit 520. Cascade connect circuit 520 receives the primary output of ULB 32 and the cascade input 52 from another logic module, and can form and output a logical combination of those two inputs if cascading of logic modules is desired. (See Cliff et al. U.S. patent 5,258,668 for more details regarding cascade connection of logic modules.) If cascading is not being done, circuit 520 merely passes the primary output of ULB 32 to its



output. In addition to being applied to one of the inputs of PLC 530, the output of circuit 520 is also applied to cascade output 52 and to one input of each of PLCs 540a and 540b. This latter circuit path allows  
5 the output of circuit 520 to bypass flip-flop 34 if it is not desired for that output of the logic module to be registered by the flip-flop. The circuit path from input D through PLCs 530 and 532 to the D input of  
10 flip-flop 34 can then be used to allow the flip-flop to register input D. Thus both the combinatorial and register portions of the circuit can be used independently if desired, thereby increasing circuit component utilization. Combinatorial components 32 and  
15 520 can be used on inputs A-C and 52 (and even input D if duplicate use of input D is desired), while register component 34 is used to register input D. Moreover, PLCs 540a and 540b (each of which can select as its  
20 output either the combinatorial output of circuit 520 or the registered output of flip-flop 34) allow either the registered or combinatorial output of the logic module to be applied to either the local feedback conductor 100 or the more global output 38 of the logic  
module. In other words, the local feedback signal 100 of the logic module can be either its registered or  
25 combinatorial output, and the more global output 38 can be independently chosen to be either the registered or combinatorial output.

FIG. 8 also shows the arithmetic carry logic 550 of logic module 30. (As mentioned above, the carry  
30 aspects of logic module 30 are shown and described in more detail in Cliff et al. U.S. patent 5,274,581.) The carry in signal 54 is applied to one input of PLC 502c and also to carry logic 550. Carry logic 550 also receives two intermediate output signals of ULB 32, and

on the basis of its three inputs, carry logic 550 produces a carry out signal 54.

FIG. 8 still further shows the clock and clear circuitry for logic module 30. Two of conductors 5 220 (i.e., the CLK0 and CLK1 clock conductors) are connected to the inputs of PLC 560a. PLC 560a is programmed to select one of these clock signals for application to clock and asynchronous load control circuit 562. The other input to circuit 562 is the 10 signal on the CLR1/ALD conductor 220. The output signal of circuit 562 is applied to the clock input terminal 536 of flip-flop 34 for clocking data into the flip-flop via its D input terminal or for asynchronously loading data into the flip-flop via the 15 terminal connected directly to D input 36.

PLC 560b can connect CLR1/ALD conductor 220, CLR0 conductor 220, or ground to clear control circuit 564. The other input to circuit 564 comes from a universal reset conductor 576 which extends adjacent to 20 all of the logic modules 30 in the device. The output signal of clear control circuit 564 is applied to the clear input terminal of flip-flop 34. If FCE 574 is programmed to select a global reset option, then PLC 572 is enabled to connect device input pin 570 (similar 25 to any of pins 130 or 150) to universal reset conductor 576. The device input signal applied to input pin 570 can then be used to reset all of the flip-flops 34 in the device.

In the presently preferred embodiment all of 30 elements 502, 530, 532, 540, and 560 are multiplexers.

FIG. 9 shows a typical input/output cell 600 associated with a horizontal input/output pin 130. Similar input/output cells are associated with vertical input/output pins 150. However, in those cells the 35 global horizontal 60 or half-horizontal 70 inputs and

outputs shown in FIG. 9 are replaced by global vertical inputs and outputs 80. The size of the PLCs corresponding to PLCs 280 is also less in those cells because there are fewer global vertical conductors 80 associated with each column than there are horizontal conductors 60/70 associated with each row.

FIG. 9 shows that the output of PLC 280 (a multiplexer in the presently preferred embodiment) is applied to programmable inverter circuit 610. Inverter 610 either inverts or does not invert the applied signal, depending on whether an inversion option is selected by programming an FCE for that option. The output of programmable inverter 610 is applied to one input of each of PLCs 620 and 630 (multiplexers in the presently preferred embodiment). The other input to PLC 620 is the output of TTL buffer 640 from I/O pad 130. Thus PLC 620 can be programmed to apply either a device output signal from PLC 280 or a device input signal from I/O pad 130 to the data input terminal of I/O cell flip-flop 650. The output of PLC 304 (a multiplexer in the presently preferred embodiment) is applied to the clock input terminal of flip-flop 650. The output of PLC 306 (a multiplexer in the presently preferred embodiment) is applied to the clock enable input terminal of flip-flop 650. (Flip-flop 650 can only take in new data via its data input terminal if its clock input is enabled by an appropriate signal applied to its clock enable input terminal.) The output signal of PLC 308 (a multiplexer in the presently preferred embodiment) is applied to the clear input terminal of flip-flop 650 via OR gate 660.

The data output of flip-flop 650 is applied to the second input terminal of PLC 630 and to one input terminal of PLC 670 (a multiplexer in the presently preferred embodiment). The other input to

PLC 670 is the output signal of TTL buffer 640. The output signal of PLC 630 is applied to the data input terminal of tri-statable output driver 680. The signal applied to the control input terminal of driver 680 is  
5 the output signal of OR gate 690. One of the inputs to OR gate 690 is the output signal of PLC 302.

From the foregoing it will be seen that I/O cell 600 is programmable to allow flip-flop 650 to register either a device output signal passing through  
10 the cell from PLC 280 to I/O pad 130, or a device input signal passing through the cell from I/O pad 130 to drivers 132. Alternatively, I/O cell 600 is programmable to pass a signal of either of the foregoing types without registration by flip-flop 650.

15 To permit global clearing of the flip-flops 650 in all of cells 600, a global clear signal input pin 662 (similar to any of pins 130 or 150) is programmably selectively connectable to global clear conductor 668 via PLC 664. PLC 664 is controlled to  
20 make this connection by suitably programming option FCE 666. Global clear conductor 668 extends adjacent to all of cells 600 and is connected to a second input terminal of the OR gate 660 in each cell. In this way, if the global clear option is selected, a signal  
25 applied to input pin 662 can be used to simultaneously clear all of flip-flops 650 on device 10.

To permit global output enabling of drivers 680 in all of cells 600, a global output enable signal input pin 692 (similar to any of pins 130 or 150) is  
30 programmably selectively connectable to global output enable conductor 698 via PLC 694. PLC 694 is controlled to make this connection by suitably programming option FCE 696. Global output enable conductor 698 extends adjacent to all of cells 600 and  
35 is connected to a second input terminal of the OR gate

690 in each cell. In this way, if the global output enable option is selected, a signal applied to input pin 692 can be used to simultaneously enable all of devices 680 (assuming that those devices are otherwise programmed as described below to respond to an output enable control signal).

Each of devices 680 has several FCEs 682a, b, and c associated with it. FCE 682a is programmable to cause device 680 to produce either a slowed output or a fast output. This is useful to help stagger the outputs of the device to reduce noise and/or to adjust output signal timing. FCEs 682b and 682c are programmable to select various functions of device 680 as shown in the following table:

15

TABLE 4

	<u>Bit 682b</u>	<u>Bit 682c</u>	<u>Buffer Function</u>
	0	0	Input only
	0	1	Tri-state output
	1	0	Open drain
20	1	1	Output only

When FCEs 682b and 682c are programmed as shown in the first line of this table, the associated I/O pad 130 is usable only as an input pin. When FCEs 682b and 682c are programmed as shown in the second line of this table, device 680 is controlled by the output signal of OR gate 690 to be either an enabled output driver or to present a high impedance to I/O pad 130, depending on the state of the output signal of OR gate 690. When FCEs 682b and 682c are programmed as shown in the third line of this table, device 680 provides an open drain connection to pin 130. When bits 682b and 682c are programmed as shown in the fourth line of the foregoing table, device 680 functions at all times as an output buffer.

35

FIG. 10 shows an additional feature of the fast conductor system of device 10. Each of fast input

pins 180 is connected (via a TTL buffer 710) to one input terminal of each of two PLCs 720 (multiplexers in the presently preferred embodiment). There are two such PLCs 720 for each fast input because the circuitry  
5 is duplicated in the left and right halves of device 10. The input to the PLCs 720 for each of the fast inputs is a respective one of the clock enable signals from peripheral bus conductors 212. Thus the PLCs 720 for each of the fast inputs are programmable to select  
10 either the associated fast input 180 or the associated clock enable signal 212 for application to the fast conductors 170 driven (via buffers 730) by those PLCs. Because the signals on conductors 212 are derived from the programmable logic of device 10, the circuitry  
15 shown in FIG. 10 allows any of the fast conductor signals to be alternatively derived from device 10 itself, rather than from fast input pins 180.

FIG. 11 shows the manner in which cascade 52 and carry 54 connections are continued from one  
20 programmable logic region 20 in a row to another programmable logic region 20 in that row. For ease of reference in this discussion, the logic regions shown in FIG. 11 are designated 20a through 20f. FIG. 11 shows that the cascade or carry output 52 or 54 of each  
25 region 20 is normally connected (through an associated PLC 750) to the cascade or carry input of another region 20 which is spaced from the source region by an intervening region 20. Thus the cascade or carry output 52 or 54 of region 20a skips region 20b and is  
30 applied as a cascade or carry input to region 20c. The output 52/54 of region 20c in turn skips region 20d and is applied to region 20e. The intervening regions 20 that are interleaved with the chain 20a/20c/20e/... are connected in another similar chain. Thus the cascade  
35 or carry output 52 or 54 of region 20b skips region 20c

and is applied to region 20d. The output 52/54 of region 20d is applied to region 20f. Skipping intervening regions in these chains helps to spread out long cascade or carry circuits. This helps prevent  
5 congestion in the interconnection resources of the device.

FIG. 11 also shows how the cascade and carry chains are continued from region to region in the event of a region being taken out of service due to a defect  
10 in that region. In the example shown in FIG. 11 region 20d is a defective and is therefore not used. In that event both of PLCs 750c and 750d are switched to pass the signal from the region 20 to the left of the switch rather than above the switch. Thus PLC 750c is  
15 switched so that the cascade or carry output 52 or 54 of region 20b is applied to region 20e, and PLC 750d is switched so that the output 52 or 54 of region 20c is applied to region 20f. Region 20d is cut out of the cascade and carry chains, but at the same time the  
20 region-skipping nature of those chains is preserved.

It will be understood that the foregoing is only illustrative of the principles of the invention, and that various modifications can be made by those skilled in the art without departing from the scope and  
25 spirit of the invention. For example, changes can be made in the number of logic modules 30 per logic region 20, in the number of rows and/or columns of logic regions 20, in the number of each type of conductor provided, in the size of the RAM regions, etc.

The Invention Claimed Is:

1. A programmable logic array integrated circuit device comprising:

a plurality of regions of programmable logic disposed on the device in a two-dimensional array of intersecting rows and columns, each of said regions having a plurality of input terminals and an output terminal and being programmable to perform any of a plurality of logic functions on signals applied to its input terminals in order to produce an output signal applied to its output terminal;

a plurality of interconnection conductors associated with each of said rows and including a first subplurality of full-length conductors which extend continuously adjacent to and along the entire length of the associated row, a second subplurality of half-length conductors which extend continuously adjacent to and along approximately a first half of the length of the associated row, and a third subplurality of half-length conductors which are separate from the half-length conductors in said second plurality and which extend continuously adjacent to and along approximately a second half of the length of the associated row, said first and second halves being substantially mutually exclusive;

a plurality of input connectors associated with each of said regions for programmably selectively connecting each input terminal of said region to any one of a multiplicity of said conductors associated with said region, said multiplicity including at least some of the full-length and some of the half-length conductors adjacent to said region; and

a plurality of output connectors associated with each of said regions for programmably selectively connecting the output terminal of said



region to any of a further multiplicity of said conductors associated with said region, said further multiplicity including at least one of the full-length and one of the half-length conductors adjacent to said region.

2. The apparatus defined in claim 1 wherein each full-length conductor associated with each row is connected to two output connectors from regions in said row.

3. The apparatus defined in claim 1 wherein each half-length conductor associated with each row is connected to two output connectors from regions in said row that are adjacent to said half-length conductor.

4. The apparatus defined in claim 1 further comprising:

a further plurality of interconnection conductors associated with each of said columns and extending continuously adjacent to and along the associated column, and wherein said output connectors associated with each of said regions include an additional output connector for programmably selectively connecting the output terminal of said region to at least one of said conductors that are associated with the column that includes said region.

5. The apparatus defined in claim 4 wherein said output connectors associated with each of said regions include an additional multiplicity of output connectors for programmably selectively connecting the output terminal of said region to plural ones of said conductors that are associated with the column that includes said region.

6. The apparatus defined in claim 4 wherein each of said output connectors that are connected to a full-length conductor or a half-length conductor is additionally connected to one of said conductors that are associated with the column that includes the region with which that output connector is associated for alternatively programmably selectively connecting that conductor associated with that column to that full-length or half-length conductor via that output connector.

7. The apparatus defined in claim 1 further comprising:

a plurality of device input/output pins associated with each of said rows; and

programmable output switches associated with each of said input/output pins for programmably selectively applying to said input/output pin a signal on any one of a subset of the conductors associated with the row that said input/output pin is associated with, said subset including at least some of the full-length and some of the half-length conductors associated with said row.

8. The apparatus defined in claim 7 wherein each of said input/output pins is adjacent to an associated one of said halves of the row that said input/output pin is associated with, and wherein the half-length conductors that the programmable output switches associated with that input/output pin can connect to that input/output pin are adjacent to the half of said row that said input/output pin is adjacent to.

9. The apparatus defined in claim 7 further comprising:

a programmable input switch associated with each of said input/output pins for programmably selectively applying a signal on said input/output pin to one of the full-length conductors associated with the row that said input/output pin is associated with.

10. The apparatus defined in claim 6 further comprising:

a plurality of device input/output pins associated with each of said rows;

a programmable input switch associated with each of said input/output pins for programmably selectively applying a signal on said input/output pin to one of the full-length conductors associated with the row that said input/output pin is associated with;  
and

a programmable interconnection switch associated with each of said full-length conductors that can receive a signal from an input/output pin via an input switch for programmably selectively applying a signal on that full-length conductor to a conductor associated with a column.

11. A programmable logic array integrated circuit device comprising:

a plurality of regions of programmable logic disposed on the device in a two-dimensional array of intersecting rows and columns, said columns being grouped in mutually exclusive pairs of adjacent columns, each of said regions having a plurality of input terminals and an output terminal and being programmable to perform any of a plurality of logic functions on signals applied to its input terminals in

order to produce an output signal applied to its output terminal;

a plurality of interconnection conductors associated with each of said rows and extending adjacent to and along the associated row;

a further plurality of interconnection conductors associated with each of said columns and extending continuously adjacent to and along the associated column;

a plurality of input connectors associated with each of said regions for programmably selectively connecting each input terminal of said region to any of a multiplicity of the conductors adjacent to said region;

a plurality of output connectors associated with each of said regions for programmably selectively connecting a signal applied to said output connectors to at least one of the conductors that are associated with the row that includes said region and to at least one of the conductors that are associated with the column that includes said region; and

a programmable switch associated with each of said regions for programmably selectively applying to said output connectors that are associated with said region the output signal of said region or the output signal of another region which is adjacent to said region but in the column that is in the pair with the column that includes said region.

12. The apparatus defined in claim 11 wherein the region associated with each of said programmable switches is in the same row as said another region which is adjacent to said region.

13. The apparatus defined in claim 11 wherein said conductors associated with each of said rows include a first subplurality of full-length conductors which extend continuously adjacent to and along the entire length of the associated row, a second subplurality of half-length conductors which extend continuously adjacent to and along approximately a first half of the length of the associated row, and a third subplurality of half-length conductors which extend continuously adjacent to and along approximately a second half of the length of the associated row, said first and second halves being substantially mutually exclusive, and wherein said output connectors associated with each of said regions includes output connectors for programmably selectively connecting the signal applied to said output connectors to at least one of the full-length conductors and one of the half-length conductors that are associated with the row that includes said region and that are adjacent to said region.

14. The apparatus defined in claim 11 wherein the output connectors associated with each region and the output connectors associated with said another region which is adjacent to said regions programmably selectively apply signals to mutually exclusive ones of the conductors that are associated with the row that includes said region.

15. A programmable logic array integrated circuit device comprising:  
a plurality of programmable logic modules, each of which has a plurality of logic module input terminals, first and second logic module output terminals, and a register for registering a signal

applied to a register input terminal and applying the registered signal to a register output terminal, each of said logic modules being programmable to produce an intermediate signal which is any of a plurality of logic functions of signals applied to said logic module input terminals, each logic module further including a first programmable switch for programmably selectively applying the signal applied to one of said input terminals or said intermediate signal to said register input terminal, a second programmable switch for programmably selectively applying said intermediate signal or said registered signal to said first logic module output terminal, and a third programmable switch for programmably selectively applying said intermediate signal or said registered signal to said second logic module output terminal;

a first conductor for conveying the signal applied to said first logic module output terminal adjacent a first subplurality of said logic modules so that the signal conveyed by said first conductor can be applied to the input terminals of said first subplurality of said logic modules; and

a second conductor for conveying the signal applied to said second logic module output terminal adjacent to a second subplurality of said logic modules so that the signal conveyed by said second conductor can be applied to the input terminals of said second subplurality of said logic modules.

16. The apparatus defined in claim 15 wherein said first subplurality is a subset of said second subplurality.

17. The apparatus defined in claim 15 wherein said logic modules are grouped in a plurality

of mutually exclusive groups of plural logic modules, and wherein each said first subplurality is coextensive with one of said groups.

18. The apparatus defined in claim 17 wherein each said second subplurality includes multiple ones of said groups.

19. The apparatus defined in claim 17 wherein each logic module is in the group that the first conductor conveying a signal from that logic module can convey that signal adjacent to.

20. The apparatus defined in claim 18 wherein each logic module is in one of the groups that the second conductor conveying a signal from that logic module can convey that signal adjacent to.

21. A programmable logic array integrated circuit device comprising:

a plurality of programmable logic modules, each of which is programmable to perform any of a plurality of logic functions on signals applied to said logic module, and each of which includes a register for registering a signal associated with said logic module, said register have a clear input terminal and being cleared by a predetermined signal applied to said clear input terminal;

a clear input pin;

a clear conductor extending from said clear input pin adjacent to each of said logic modules;

a programmable function control element for programmably selecting a global clear mode of operation; and

clear control circuitry responsive to said architecture control bit for operatively connecting said clear input terminal of the register of each of said logic modules to said clear conductor when said global clear mode of operation is selected, thereby allowing all of said registers to be cleared by an appropriate signal applied to said clear input pin.

22. A programmable logic module for a programmable logic array integrated circuit device comprising:

programmable logic circuitry for performing any of a plurality of logic functions on a plurality of input signals applied to said logic circuitry in order to produce an output signal of said logic circuitry;

a flip-flop circuit for registering a signal applied to a data input terminal of said flip-flop circuit in response to a clock signal applied to a clock input terminal of said flip-flop circuit to produce a registered output signal of said flip-flop circuit; and

switch circuitry for selectively applying either the output signal of said logic circuitry or the registered output signal of said flip-flop circuit to said data input terminal of said flip-flop circuit depending on the states of first and second control signals applied to said switch circuitry, said switch circuitry responding to a first state of said first control signal by always connecting said output signal of said logic circuitry to said data input terminal of said flip-flop circuit regardless of the state of said second control signal, and said switch circuitry responding to a second state of said first control signal by connecting said output signal



of said logic circuitry to said data input terminal of said flip-flop circuit in response to a first state of said second control signal and by connecting said registered output signal of said flip-flop circuit to said data input terminal of said flip-flop circuit in response to a second state of said second control signal.

23. The apparatus defined in claim 22 wherein said first control signal is produced by a programmable function control element of said programmable logic array integrated circuit device.

24. The apparatus defined in claim 22 wherein said second control signal is one of the input signals applied to said logic circuitry.

25. An input/output cell for a programmable logic array integrated circuit comprising:

an input/output pin for use in connecting said programmable logic array integrated circuit to external circuitry;

an input terminal for enabling said input/output cell to receive a signal from other portions of said programmable logic array integrated circuit;

an output terminal for enabling said input/output cell to output a signal to other portions of said programmable logic array integrated circuit;

a register circuit for registering a signal applied to a data input port of said register circuit in response to a clock signal applied to said register circuit in order to produce a registered output signal of said register circuit;

a first programmable switch for applying either a signal applied to said input/output pin or a signal applied to said input terminal to said input port;

a second programmable switch for applying said registered output signal to either said input/output pin or to said output terminal; and

clock enable circuitry for selectively preventing said register circuit from responding to said clock signal.

26. The apparatus defined in claim 25 wherein said input/output cell is one of a plurality of similar input/output cells on said programmable logic array integrated circuit, and wherein said programmable logic array integrated circuit further comprises:

a plurality of clock enable signal conductors extending adjacent to each of said input/output cells; and

a third programmable switch associated with each of said input/output cells for selecting any one of said clock enable signal conductors as the source of a clock enable signal applied to the clock enable circuitry in that input/output cell.

27. The apparatus defined in claim 26 wherein said programmable logic array integrated circuit further comprises:

programmable logic array circuitry which is programmable to produce a logic array output signal which is any of a plurality of logic functions of a plurality input signals applied to said programmable logic array circuitry; and

a fourth programmable switch for selectively applying said logic array output signal to

a predetermined one of said clock enable signal conductors.

28. The apparatus defined in claim 26 wherein said programmable logic array integrated circuit further comprises:

a plurality of regions of programmable logic circuitry disposed on said integrated circuit in a two-dimensional array of intersecting rows and columns, each row and each column producing an associated plurality of logic array output signals, wherein each of said input/output cells is associated with a respective one of said rows or columns, and wherein said third programmable switch associated with each input/output cell can alternatively select one of the logic array output signals associated with the row or column that the input/output cell is associated with as the source of the clock enable signal applied to the clock enable circuitry in that input/output cell.

29. An input/output cell for a programmable logic array integrated circuit comprising:

an input/output pin for use in connecting said programmable logic array integrated circuit to external circuitry;

an input terminal for enabling said input/output cell to receive a signal from other portions of said programmable logic array integrated circuit; and

a programmable output driver circuit for selectively applying the signal received by said input terminal to said input/output pin, said programmable output driver circuit being alternatively programmable to connect an open drain circuit to said input/output pin.

30. A programmable logic array integrated circuit device comprising:

a plurality of regions of programmable logic circuitry disposed on said integrated circuit in a two-dimensional array of intersecting rows and columns;

a plurality of input/output cells, each of which is associated with a respective one of said rows or columns, and each of which (1) includes an input/output pin for use in connecting said programmable logic array integrated circuit to external circuitry, (2) an input terminal for enabling said input/output cell to receive a signal from other portions of said programmable logic array integrated circuit, and (3) a controllable output driver circuit for selectively applying the signal received by said input terminal to said input/output pin when enabled by an output enable signal applied to an output enable input terminal of said output driver circuit;

an output enable input pin;

an output enable conductor extending from said output enable input pin adjacent to each of said input/output cells;

a programmable function control element for programmably selecting a global output enable mode of operation; and

output enable control circuitry responsive to said function control element for operatively connecting said output enable input terminal of the output driver circuit in each of said input/output cells to said output enable conductor when said global output enable mode of operation is selected.

31. The apparatus defined in claim 30 wherein the input terminal of each input/output cell receives its signal from the row or column associated with that input/output cell.

32. A programmable logic array integrated circuit device comprising:

a plurality of input/output cells, each of which includes (1) an input/output pin for use in connecting said programmable logic array integrated circuit to external circuitry, and (2) a register circuit for selectively registering a data signal being passed through said input/output cell between said input/output pin and other portions of said device, said register circuit registering said data signal in response to a clock signal applied to a clock input terminal of said register circuit;

a plurality of clock input pins;

a plurality of clock conductors, each of which extends from a respective one of said clock input pins adjacent to each of said input/output cells; and

a programmable switch associated with each of said input/output cells for programmably selecting any of said clock conductors as the source of a clock signal applied the clock input terminal of the register circuit in that input/output cell.

33. The apparatus defined in claim 32 wherein each input/output cell further includes clock enable circuitry for selectively enabling the register circuit in that input/output cell to respond to the clock signal applied to the clock input terminal of that register.

34. The apparatus defined in claim 33 further comprising:

a plurality of clock enable signal conductors extending adjacent to each of said input/output cells, and wherein each input/output cell further includes another programmable switch for programmably selecting any of said clock enable signal conductors as the source of a clock enable signal applied to the clock enable circuitry of that input/output cell.

35. The apparatus defined in claim 34 wherein said programmable logic array integrated circuit device further comprises:

programmable logic array circuitry which is programmable to produce a logic array output signal which is any of a plurality of logic functions of a plurality of input signals applied to said programmable logic array integrated circuit; and

a further programmable switch for selectively applying said logic array output signal to a predetermined one of said clock enable signal conductors.

36. A programmable logic array integrated circuit device comprising:

programmable logic array circuitry which is programmable to produce a plurality of output signals applied to said programmable logic circuitry;

a plurality of output pins for use in connecting said device to external circuitry;

an output driver circuit associated with each of said output pins, each of said output driver circuits being operable to selectively apply an associated first one of said output signals to the

associated output pin when said output driver circuit is enabled by an output enable signal applied to an output enable terminal of said output driver circuit; and

an output enable control circuit associated with each of said output driver circuits for applying an associated second one of said output signals to the output enable terminal of said output driver circuit.

37. The apparatus defined in claim 36 wherein each of said output enable control circuits comprises:

a programmable switch for programmably selecting any one of a subplurality of said output signals for application to the output enable terminal of the output driver circuit associated with said output enable control circuit.

38. The apparatus defined in claim 36 further comprising:

a programmable switch associated with each of said output driver circuits for programmably selecting any one of a subplurality of said output signals as said first one of said output signals associated with said output driver circuit.

39. The apparatus defined in claim 36 wherein said programmable logic array circuitry comprises:

a plurality of regions of programmable logic, said regions being disposed on said device in a two-dimensional array of intersecting rows and columns of said regions, each of said rows and columns having an associated one of said output pins.

40. The apparatus defined in claim 39 wherein each of said rows and columns has an associated plurality of conductors for conveying certain ones of said output signals that are thereby associated with the row or column that said conductors are associated with.

41. The apparatus defined in claim 40 wherein each of said output enable control circuits comprises:

a programmable switch for programmably selecting one of the conductors associated with the row or column that the output pin associated with said output enable control circuit is associated with as the source of the output signal applied to the output enable terminal for the output driver circuit associated with that output enable control circuit.

42. A programmable logic array integrated circuit device comprising:

a plurality of regions of programmable logic disposed on said device in a two-dimensional array of intersecting rows and columns, each of said regions being programmable to produce at least one primary output signal which is any of a plurality of logic functions of a plurality of input signals applied to said region, said input signals including a plurality of primary input signals and a secondary input signal, and each of said regions being additionally programmable to produce a secondary output signal which is a logic function of said input signals applied to said region;

a plurality of row conductors associated with each of said rows, the row conductors associated



with each row being adjacent to and extending along that row for conveying said primary input or primary output signals for regions in that row;

a plurality of column conductors associated with each of said columns, the column conductors associated with each column being adjacent to and extending along that column for conveying said primary input or primary output signals for regions in that column;

a secondary conductor associated with each region in each row for conveying the secondary output signal of the associated region to provide the secondary input signal of another region in that row, said another region being associated with but spaced from said region along said row by an intervening region which is between said region and said another region.

43. The apparatus defined in claim 42 wherein said another region associated with each region in a row is spaced from that region in a predetermined direction along said row, said predetermined direction being the same for all regions in said row.

44. The apparatus defined in claim 42 wherein said secondary output signal is a carry signal from a place of binary arithmetic performed by said region producing said secondary output signal.

45. The apparatus defined in claim 42 wherein said secondary output signal is a cascade signal from said region producing said secondary output signal, which cascade signal is to be logically combined by said another region receiving that signal

with a logic signal produced by said another region from said primary input signals to said another region.

46. A programmable logic array integrated circuit device comprising:

a plurality of regions of programmable logic circuitry, each of said regions being programmable to produce an output signal which is any of a plurality of logic functions of a plurality of input signals applied to said region;

a universal signal conductor which extends adjacent to each of said regions;

a first programmable switch associated with each of said regions for programmably selectively applying a signal on said universal signal conductor to said region as an input signal;

an input pin for use in receiving a signal from circuitry external to said device; and

a second programmable switch for programmably selectively applying to said universal signal conductor either a signal received by said input pin or an output signal from one of said regions.

**Amendments to the claims have been filed as follows**

CLAIMS

1. A programmable logic array integrated circuit device comprising:
  - a plurality of regions of programmable logic circuitry, each of said regions being programmable to produce an output signal which is any of a plurality of logic functions of a plurality of input signals applied to said region;
  - a universal signal conductor which extends adjacent to each of said regions;
  - a first programmable switch associated with each of said regions for programmably selectively applying a signal on said universal signal conductor to said region as an input signal;
  - an input pin for use in receiving a signal from circuitry external to said device; and
  - a second programmable switch for programmably selectively applying to said universal signal conductor either a signal received by said input pin or an output signal from one of said regions.



Application No: GB 9909316.3  
Claims searched: 1 (as amended 22.4.99)

Examiner: Mike Davis  
Date of search: 27 May 1999

**Patents Act 1977**  
**Search Report under Section 17**

**Databases searched:**

UK Patent Office collections, including GB, EP, WO & US patent specifications, in:  
UK Cl (Ed.Q): G4H (HU)  
Int Cl (Ed.6): H03K  
Other:

**Documents considered to be relevant:**

Category	Identity of document and relevant passage	Relevant to claims
	None	

X	Document indicating lack of novelty or inventive step	A	Document indicating technological background and/or state of the art.
Y	Document indicating lack of inventive step if combined with one or more other documents of same category.	P	Document published on or after the declared priority date but before the filing date of this invention.
&	Member of the same patent family	E	Patent document published on or after, but with priority date earlier than, the filing date of this application.