

No. 831,660.

PATENTED SEPT. 25, 1906.

R. K. FLOETER.
AUTOMATIC RAILROAD SWITCH.

APPLICATION FILED FEB. 23, 1906.

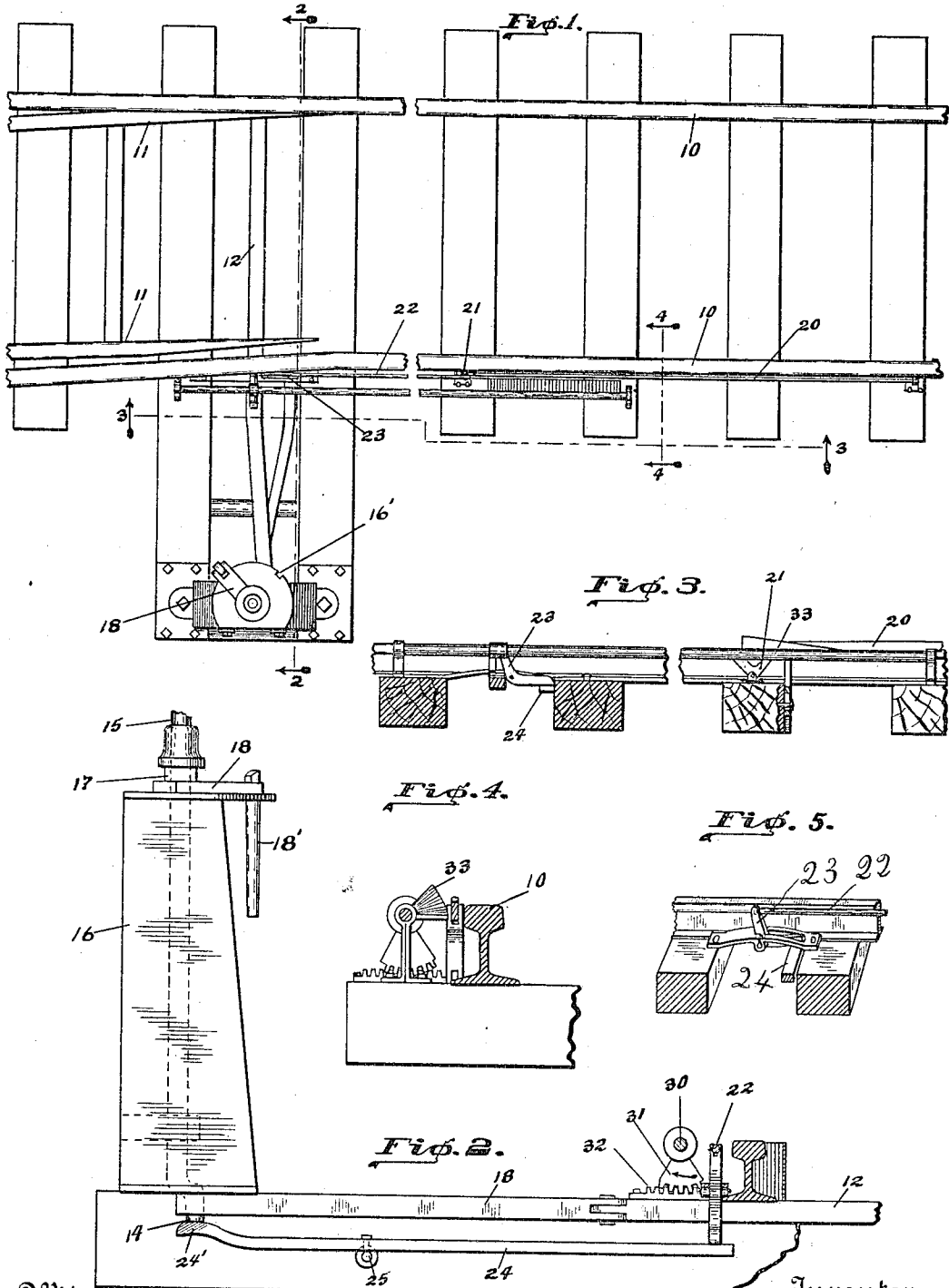

Witnesses
Vernon Plummer.
Thomas H. McMeans.

Inventor
Robert K. Floeter.

By
Bradford Hood
Attorneys.

UNITED STATES PATENT OFFICE.

ROBERT K. FLOETER, OF LIMA, OHIO.

AUTOMATIC RAILROAD-SWITCH.

No. 831,660.

Specification of Letters Patent.

Patented Sept. 25, 1906.

Application filed February 23, 1906. Serial No. 302,375.

To all whom it may concern:

Be it known that I, ROBERT K. FLOETER, a citizen of the United States, residing at Lima, in the county of Allen and State of Ohio, have invented certain new and useful Improvements in Automatic Railroad-Switches, of which the following is a specification.

My invention relates to an improvement in that form of train-operated switches, particularly the form described and claimed in Patent No. 811,627, issued to me February 6, 1906.

The object of my present invention is to provide positively-operated means for throwing the switch to closed position.

The accompanying drawings illustrate my invention.

Figure 1 is a plan; Fig. 2, a transverse elevation; Fig. 3, a section on line 3 3, Fig. 1; Fig. 4, a section on line 4 4 of Fig. 1, and Fig. 5 a perspective detail.

In the drawings, 10 10 indicate the main rails, 10' the siding, and 11 11 the switch-points which are connected together by a bar 12. Pivoted to one end of bar 12, so as to swing in a horizontal plane, is a link 13, which is connected to the lower cranked end 14 of the switch-stand shaft 15. The shaft 15 is rotatably mounted in a suitable switch-stand 16 and is so mounted within the switch-stand that it may have a limited vertical movement as well as a rotative movement. The shaft 15 is provided immediately above the upper end of the switch 10 with a polygonal portion 17, which fits in a corresponding polygonal opening in the operating-lever 18, pivotally mounted upon the upper end of the switch-stand, as described in my above-mentioned patent, the arrangement being such that the shaft 15 may be turned to operate the switch-points 11 manually by swinging the arm 18. Arm 18 has a pivoted outer end 18', adapted to enter either one of a pair of notches 16', formed in the switch-stand, and thus hold the switch-points in either open or closed position.

Mounted alongside the track is a bar 20, which is adapted to be engaged by a portion carried by the locomotive and depressed thereby as the train advances from right to left along the track shown in Fig. 1. The forward end of bar 20 is connected to one arm of a bell-crank 21, pivoted alongside the track, the other arm of said bell-crank being connected by a link 22 with one arm of a bell-crank 23, also pivoted alongside the track.

The other arm of the bell-crank 23 is adapted to engage a lever 24, pivoted at 25 and extended into the path of movement of the crank 14, said lever 24 at that end being provided with a beveled end 24' to facilitate engagement between the lever and the crank when the crank has been turned to a position where the switch-points open the way to the siding.

The construction thus far described is substantially identical with the corresponding portions illustrated and claimed in my above-mentioned patent, and my present invention resides in the provision of positively-operated means for automatically throwing the switch from open to closed position by the movement of the locomotive. For this purpose I journal alongside the track a shaft 30, to which is attached a segment 31, meshing with a rack 32, attached to the bar 12, the arrangement being such that when the shaft is rotated in the direction indicated by the arrow in Fig. 2 the switch-points will be moved positively to closed position. In order to cause proper rocking of the shaft 30, I attach thereto a spiral wing 33, which is arranged to be engaged by the same means carried by the locomotive which engages the bar 20, such engagement resulting in sufficient rocking of the shaft 30 to swing the segment 31 and actuate the switch-points.

In operation, supposing the switch-points to be thrown so as to open the siding, as shown in Fig. 1, and the train to be approaching from right to left and desiring to continue upon the main line, the engineer will see that the proper element carried by the locomotive is in position to engage the bar 20 and wing 33. The first action will be a depression of bar 20 and a consequent pull upon rod 22, thus swinging the bell-crank lever 23 and moving the outer end of lever 24 upward, so as to engage the switch-stand shaft 15 and lift the polygonal portion 17 out of arm 18, thus leaving said shaft free to be turned. As the locomotive proceeds along the track the wing 33 will be engaged and shaft 30 rocked so as to cause segment 31 to engage rack 32 and shift bar 12 to the left in Fig. 2, thus positively closing the switch-points and swinging the switch-stand shaft 15 to normal position.

In order to reopen the switch, the operator must first lift shaft 15 so that the polygonal portion 17 will be withdrawn from arm 18. Thereupon said arm may be carried back to its initial position, the shaft 15 then dropped

so that its polygonal portion will enter the arm 18, and the arm 18 thereafter used to operate the switch-points.

I claim as my invention—

5 1. The combination, with the main-line and siding rails and switch-points adapted to connect one with the other, of switch-throwing means comprising a crank-shaft and an
 10 operating member therefor, a separable polygonal connection between said shaft and operating member, connections between the crank of said crank-shaft and the switch-
 15 points, means arranged alongside the track and operable by a member carried by a passing train for causing a separation of the connection between the crank-shaft and its oper-
 20 ating member, and other means also arranged alongside the track operable by a member carried by a train for shifting the switch-points in one direction.

2. The combination, with the main-line and siding rails and switch-points adapted to connect one with the other, of switch-throw-

ing means comprising a crank-shaft and oper- 25
 ating means therefor, a separable polygonal connection between said shaft and operating 30
 member, connections between the crank of said crank-shaft and the switch-points, means arranged alongside the track and oper- 35
 able by a member carried by a passing train for causing a separation of the connection between the crank-shaft and its operating
 member, a rock-shaft arranged alongside the track and provided with a spiral wing, and connections between said shaft and the
 switch-points whereby, when the said spiral wing is engaged by a member carried by the train, the switch-points will be shifted in one
 direction.

In witness whereof I have hereunto set my 40
 hand and seal, at Indianapolis, Indiana, this
 20th day of February, A. D. 1906.

ROBERT K. FLOETER. [L. s.]

Witnesses:

THOMAS W. McMEANS,
 ARTHUR M. HOOD.