

(19) World Intellectual Property Organization  
International Bureau



(43) International Publication Date  
29 August 2002 (29.08.2002)

PCT

(10) International Publication Number  
WO 02/066783 A1

- (51) International Patent Classification<sup>7</sup>: E21B 19/16, 23/00 RING, Lev [RU/US]; 14126 Heatherhill Place, Houston, TX 77077 (US).
- (21) International Application Number: PCT/US02/04353 (74) Agents: MATTINGLY, Todd et al.; Haynes and Boone, LLP, 1000 Louisiana, Suite 4300, Houston, TX 77002-5012 (US).
- (22) International Filing Date: 14 February 2002 (14.02.2002)
- (25) Filing Language: English (81) Designated States (national): AE, AG, AL, AM, AT, AU, AZ, BA, BB, BG, BR, BY, BZ, CA, CH, CN, CO, CR, CU, CZ, DE, DK, DM, DZ, EE, ES, FI, GB, GD, GE, GH, GM, HR, HU, ID, IL, IN, IS, JP, KE, KG, KP, KR, KZ, LC, LK, LR, LS, LT, LU, LV, MA, MD, MG, MK, MN, MW, MX, MZ, NO, NZ, OM, PH, PL, PT, RO, RU, SD, SE, SG, SI, SK, SL, TJ, TM, TN, TR, TT, TZ, UA, UG, US, UZ, VN, YU, ZA, ZM, ZW.
- (26) Publication Language: English (84) Designated States (regional): ARIPO patent (GH, GM, KE, LS, MW, MZ, SD, SL, SZ, TZ, UG, ZM, ZW), Eurasian patent (AM, AZ, BY, KG, KZ, MD, RU, TJ, TM), European patent (AT, BE, CH, CY, DE, DK, ES, FI, FR,
- (30) Priority Data: 60/270,007 20 February 2001 (20.02.2001) US
- (71) Applicant (for all designated States except US): ENVENTURE GLOBAL TECHNOLOGY [US/US]; 16200 A Park Row, Houston, TX 77084 (US).
- (72) Inventors; and
- (75) Inventors/Applicants (for US only): COOK, Robert, Lance [US/US]; 934 Caswell Court, Katy, TX 77450 (US).

[Continued on next page]

(54) Title: MONO-DIAMETER WELLBORE CASING

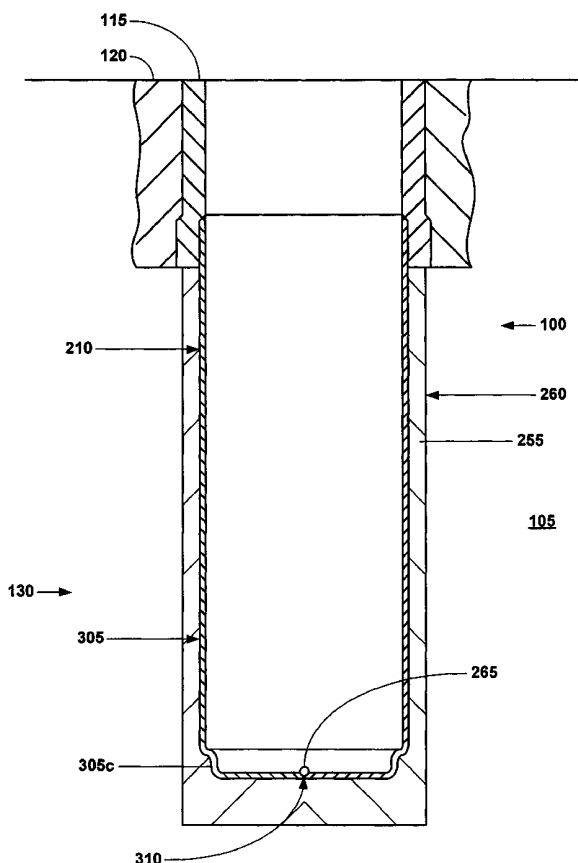

(57) Abstract: A mono-diameter wellbore (100) casing. If the fluid seal of the overlapping joint between the upper end portion (210d) of the tubular member (210) and the lower end portion (115a) of the casing (115) is satisfactory, then any uncured portion of the material (255) within the expanded tubular member (210) is removed in a conventional manner.



WO 02/066783 A1



GB, GR, IE, IT, LU, MC, NL, PT, SE, TR), OAPI patent  
(BF, BJ, CF, CG, CI, CM, GA, GN, GQ, GW, ML, MR,  
NE, SN, TD, TG).

— before the expiration of the time limit for amending the  
claims and to be republished in the event of receipt of  
amendments

**Declaration under Rule 4.17:**

— of inventorship (Rule 4.17(iv)) for US only

**Published:**

— with international search report

For two-letter codes and other abbreviations, refer to the "Guid-  
ance Notes on Codes and Abbreviations" appearing at the begin-  
ning of each regular issue of the PCT Gazette.

## MONO-DIAMETER WELLBORE CASING

## Cross Reference To Related Applications

This application is a continuation-in-part of U.S. utility application serial number 09/454,139, attorney docket number 25791.3.02, filed on 12/3/1999, which  
5 claimed the benefit of the filing date of U.S. provisional patent application serial number 60/111,293, attorney docket number 25791.3, filed on 12/7/1998, the disclosures of which are incorporated herein by reference.

This application is related to the following: (1) U.S. patent application serial no. 09/454,139, attorney docket no. 25791.03.02, filed on 12/3/1999, (2) U.S. patent  
10 application serial no. 09/510,913, attorney docket no. 25791.7.02, filed on 2/23/2000, (3) U.S. patent application serial no. 09/502,350, attorney docket no. 25791.8.02, filed on 2/10/2000, (4) U.S. patent application serial no. 09/440,338, attorney docket no. 25791.9.02, filed on 11/15/1999, (5) U.S. patent application serial no. 09/523,460, attorney docket no. 25791.11.02, filed on 3/10/2000, (6) U.S. patent application serial no.  
15 09/512,895, attorney docket no. 25791.12.02, filed on 2/24/2000, (7) U.S. patent application serial no. 09/511,941, attorney docket no. 25791.16.02, filed on 2/24/2000, (8) U.S. patent application serial no. 09/588,946, attorney docket no. 25791.17.02, filed on 6/7/2000, (9) U.S. patent application serial no. 09/559,122, attorney docket no. 25791.23.02, filed on 4/26/2000, (10) PCT patent application serial no. PCT/US00/18635,  
20 attorney docket no. 25791.25.02, filed on 7/9/2000, (11) U.S. provisional patent application serial no. 60/162,671, attorney docket no. 25791.27, filed on 11/1/1999, (12) U.S. provisional patent application serial no. 60/154,047, attorney docket no. 25791.29, filed on 9/16/1999, (13) U.S. provisional patent application serial no. 60/159,082, attorney docket no. 25791.34, filed on 10/12/1999, (14) U.S. provisional patent  
25 application serial no. 60/159,039, attorney docket no. 25791.36, filed on 10/12/1999, (15) U.S. provisional patent application serial no. 60/159,033, attorney docket no. 25791.37, filed on 10/12/1999, (16) U.S. provisional patent application serial no. 60/212,359, attorney docket no. 25791.38, filed on 6/19/2000, (17) U.S. provisional patent application serial no. 60/165,228, attorney docket no. 25791.39, filed on 11/12/1999, (18) U.S.  
30 provisional patent application serial no. 60/221,443, attorney docket no. 25791.45, filed on 7/28/2000, (19) U.S. provisional patent application serial no. 60/221,645, attorney docket no. 25791.46, filed on 7/28/2000, (20) U.S. provisional patent application serial no. 60/233,638, attorney docket no. 25791.47, filed on 9/18/2000, (21) U.S. provisional patent application serial no. 60/237,334, attorney docket no. 25791.48, filed on

10/2/2000, and (22) U.S. provisional patent application serial no. 60/262,434, attorney docket no. 25791.51, filed on 1/17/2001, the disclosures of which are incorporated herein by reference.

### Background of the Invention

5 This invention relates generally to wellbore casings, and in particular to wellbore casings that are formed using expandable tubing.

Conventionally, when a wellbore is created, a number of casings are installed in the borehole to prevent collapse of the borehole wall and to prevent undesired outflow of drilling fluid into the formation or inflow of fluid from the formation into the  
10 borehole. The borehole is drilled in intervals whereby a casing which is to be installed in a lower borehole interval is lowered through a previously installed casing of an upper borehole interval. As a consequence of this procedure the casing of the lower interval is of smaller diameter than the casing of the upper interval. Thus, the casings are in a nested arrangement with casing diameters decreasing in downward direction. Cement  
15 annuli are provided between the outer surfaces of the casings and the borehole wall to seal the casings from the borehole wall. As a consequence of this nested arrangement a relatively large borehole diameter is required at the upper part of the wellbore. Such a large borehole diameter involves increased costs due to heavy casing handling equipment, large drill bits and increased volumes of drilling fluid and drill cuttings.  
20 Moreover, increased drilling rig time is involved due to required cement pumping, cement hardening, required equipment changes due to large variations in hole diameters drilled in the course of the well, and the large volume of cuttings drilled and removed.

The present invention is directed to overcoming one or more of the limitations of  
25 the existing procedures for forming new sections of casing in a wellbore.

### Summary of the Invention

According to one aspect of the present invention, an apparatus for forming a wellbore casing in a borehole located in a subterranean formation including a  
preexisting wellbore casing is provided that includes a support member including a first  
30 fluid passage, an expansion cone coupled to the support member including a second fluid passage fluidically coupled to the first fluid passage, an expandable tubular liner movably coupled to the expansion cone, and an expandable shoe coupled to the expandable tubular liner.

According to another aspect of the present invention, a shoe is provided that includes an upper annular portion, an intermediate annular portion, and a lower annular portion. The intermediate annular portion has an outer circumference that is larger than the outer circumferences of the upper and lower annular portions.

5           According to another aspect of the present invention, a method of forming a wellbore casing in a subterranean formation having a preexisting wellbore casing positioned in a borehole is provided that includes installing a tubular liner, an expansion cone, and a shoe in the borehole, radially expanding at least a portion of the shoe by injecting a fluidic material into the shoe, and radially expanding at least a  
10           portion of the tubular liner by injecting a fluidic material into the borehole below the expansion cone.

          According to another aspect of the present invention, an apparatus for forming a wellbore casing in a subterranean formation having a preexisting wellbore casing positioned in a borehole is provided that includes means for installing a tubular liner, an  
15           expansion cone, and a shoe in the borehole, means for radially expanding at least a portion of the shoe, and means for radially expanding at least a portion of the tubular liner.

          According to another aspect of the present invention, an apparatus for forming a wellbore casing within a subterranean formation including a preexisting wellbore casing  
20           positioned in a borehole is provided that includes a tubular liner, and means for radially expanding and coupling the tubular liner to an overlapping portion of the preexisting wellbore casing. The inside diameter of the radially expanded tubular liner is substantially equal to the inside diameter of a non-overlapping portion of the preexisting wellbore casing.

25           According to another aspect of the present invention, a wellbore casing positioned in a borehole within a subterranean formation is provided that includes a first wellbore casing, and a second wellbore casing coupled to and overlapping with the first wellbore casing. The second wellbore casing is coupled to the first wellbore casing by the process of: installing the second wellbore casing, an expansion cone, and a shoe in  
30           the borehole, radially expanding at least a portion of the shoe by injecting a fluidic material into the shoe, and radially expanding at least a portion of the second wellbore casing by injecting a fluidic material into the borehole below the expansion cone.

          According to another aspect of the present invention, a method of forming a tubular structure in a subterranean formation having a preexisting tubular member

positioned in a borehole is provided that includes installing a tubular liner, an expansion cone, and a shoe in the borehole, radially expanding at least a portion of the shoe by injecting a fluidic material into the shoe, and radially expanding at least a portion of the tubular liner by injecting a fluidic material into the borehole below the expansion cone.

According to another aspect of the present invention, an apparatus for forming a tubular structure in a subterranean formation having a preexisting tubular member positioned in a borehole is provided that includes means for installing a tubular liner, an expansion cone, and a shoe in the borehole, means for radially expanding at least a portion of the shoe, and means for radially expanding at least a portion of the tubular liner.

According to another aspect of the present invention, an apparatus for forming a tubular structure within a subterranean formation including a preexisting tubular member positioned in a borehole is provided that includes a tubular liner and means for radially expanding and coupling the tubular liner to an overlapping portion of the preexisting tubular member. The inside diameter of the radially expanded tubular liner is substantially equal to the inside diameter of a non-overlapping portion of the preexisting tubular member.

According to another aspect of the present invention, a tubular structure positioned in a borehole within a subterranean formation is provided that includes a first tubular member and a second tubular member coupled to and overlapping with the first tubular member. The second tubular member is coupled to the first tubular member by the process of: installing the second tubular member, an expansion cone, and a shoe in the borehole, radially expanding at least a portion of the shoe by injecting a fluidic material into the shoe, and radially expanding at least a portion of the second tubular member by injecting a fluidic material into the borehole below the expansion cone.

#### Brief Description of the Drawings

FIG. 1 is a fragmentary cross-sectional view illustrating the drilling of a new section of a well borehole.

FIG. 2 is a fragmentary cross-sectional view illustrating the placement of an embodiment of an apparatus for creating a mono-diameter wellbore casing within the new section of the well borehole of FIG. 1.

FIG. 2a is a cross-sectional view of a portion of the shoe of the apparatus of FIG. 2.

FIG. 2b is a cross-sectional view of another portion of the shoe of the apparatus of FIG. 2.

5 FIG. 2c is a cross-sectional view of another portion of the shoe of the apparatus of FIG. 2.

FIG. 2d is a cross-sectional view of another portion of the shoe of the apparatus of FIG. 2.

10 FIG. 2e is a cross-sectional view of a portion of the shoe of the apparatus of FIG. 2c.

FIG. 3 is a fragmentary cross-sectional view illustrating the injection of a hardenable fluidic sealing material through the apparatus and into the new section of the well borehole of FIG. 2.

15 FIG. 3a is a cross-sectional view of a portion of the shoe of the apparatus of FIG. 3.

FIG. 3b is a cross-sectional view of a portion of the shoe of the apparatus of FIG. 3a.

FIG. 4 is a fragmentary cross-sectional view illustrating the injection of a fluidic material into the apparatus of FIG. 3 in order to fluidically isolate the interior of the shoe.

20 FIG. 4a is a cross-sectional view of a portion of the shoe of the apparatus of FIG. 4.

FIG. 4b is a cross-sectional view of a portion of the shoe of the apparatus of FIG. 4a.

25 FIG. 5 is a cross-sectional view illustrating the radial expansion of the shoe of FIG. 4.

FIG. 6 is a cross-sectional view illustrating the lowering of the expandable expansion cone into the radially expanded shoe of the apparatus of FIG. 5.

FIG. 7 is a cross-sectional view illustrating the expansion of the expandable expansion cone of the apparatus of FIG. 6.

30 FIG. 8 is a cross-sectional view illustrating the injection of fluidic material into the radially expanded shoe of the apparatus of FIG. 7.

FIG. 9 is a cross-sectional view illustrating the completion of the radial expansion of the expandable tubular member of the apparatus of FIG. 8.

FIG. 10 is a cross-sectional view illustrating the removal of the bottom portion of the radially expanded shoe of the apparatus of FIG. 9.

FIG. 11 is a cross-sectional view illustrating the formation of a mono-diameter wellbore casing that includes a plurality of overlapping mono-diameter wellbore casings.

5 FIG. 12 is a fragmentary cross-sectional view illustrating the placement of an alternative embodiment of an apparatus for creating a mono-diameter wellbore casing within the wellbore of FIG. 1.

FIG. 12a is a cross-sectional view of a portion of the shoe of the apparatus of FIG. 12.

10 FIG. 12b is a cross-sectional view of a portion of the shoe of the apparatus of FIG. 12.

FIG. 12c is a cross-sectional view of another portion of the shoe of the apparatus of FIG. 12.

15 FIG. 12d is a cross-sectional view of another portion of the shoe of the apparatus of FIG. 12.

FIG. 13 is a fragmentary cross-sectional view illustrating the injection of a hardenable fluidic sealing material through the apparatus and into the new section of the well borehole of FIG. 12.

20 FIG. 13a is a cross-sectional view of a portion of the shoe of the apparatus of FIG. 13.

FIG. 14 is a fragmentary cross-sectional view illustrating the injection of a fluidic material into the apparatus of FIG. 13 in order to fluidically isolate the interior of the shoe.

25 FIG. 14a is a cross-sectional view of a portion of the shoe of the apparatus of FIG. 14.

FIG. 15 is a cross-sectional view illustrating the radial expansion of the shoe of FIG. 14.

FIG. 16 is a cross-sectional view illustrating the lowering of the expandable expansion cone into the radially expanded shoe of the apparatus of FIG. 15.

30 FIG. 17 is a cross-sectional view illustrating the expansion of the expandable expansion cone of the apparatus of FIG. 16.

FIG. 18 is a cross-sectional view illustrating the injection of fluidic material into the radially expanded shoe of the apparatus of FIG. 17.



FIG. 19 is a cross-sectional view illustrating the completion of the radial expansion of the expandable tubular member of the apparatus of FIG. 18.

FIG. 20 is a cross-sectional view illustrating the removal of the bottom portion of the radially expanded shoe of the apparatus of FIG. 19.

5

#### Detailed Description of the Illustrative Embodiments

Referring initially to FIGS. 1, 2, 2a, 2b, 2c, 2d, 2e, 3, 3a, 3b, 4, 4a, 4b, and 5-10, an embodiment of an apparatus and method for forming a mono-diameter wellbore casing within a subterranean formation will now be described. As illustrated in Fig. 1, a wellbore 100 is positioned in a subterranean formation 105. The wellbore 100 includes a pre-existing cased section 110 having a tubular casing 115 and an annular outer layer 120 of a fluidic sealing material such as, for example, cement. The wellbore 100 may be positioned in any orientation from vertical to horizontal. In several alternative embodiments, the pre-existing cased section 110 does not include the annular outer layer 120.

15

In order to extend the wellbore 100 into the subterranean formation 105, a drill string 125 is used in a well known manner to drill out material from the subterranean formation 105 to form a new wellbore section 130. In a preferred embodiment, the inside diameter of the new wellbore section 130 is greater than the inside diameter of the preexisting wellbore casing 115.

20

As illustrated in FIGS. 2, 2a, 2b, 2c, 2d, and 2e, an apparatus 200 for forming a wellbore casing in a subterranean formation is then positioned in the new section 130 of the wellbore 100. The apparatus 200 preferably includes an expansion cone 205 having a fluid passage 205a that supports a tubular member 210 that includes a lower portion 210a, an intermediate portion 210b, an upper portion 210c, and an upper end portion 210d.

25

The expansion cone 205 may be any number of conventional commercially available expansion cones. In several alternative embodiments, the expansion cone 205 may be controllably expandable in the radial direction, for example, as disclosed in U.S. patent nos. 5,348,095, and/or 6,012,523, the disclosures of which are incorporated herein by reference.

30

The tubular member 210 may be fabricated from any number of conventional commercially available materials such as, for example, Oilfield Country Tubular Goods (OCTG), 13 chromium steel tubing/casing, or plastic tubing/casing. In a preferred embodiment, the tubular member 210 is fabricated from OCTG in order to maximize

strength after expansion. In several alternative embodiments, the tubular member 210 may be solid and/or slotted. For typical tubular member 210 materials, the length of the tubular member 210 is preferably limited to between about 40 to 20,000 feet in length.

5           The lower portion 210a of the tubular member 210 preferably has a larger inside diameter than the upper portion 210c of the tubular member. In a preferred embodiment, the wall thickness of the intermediate portion 210b of the tubular member 201 is less than the wall thickness of the upper portion 210c of the tubular member in order to facilitate the initiation of the radial expansion process. In a preferred  
10           embodiment, the upper end portion 210d of the tubular member 210 is slotted, perforated, or otherwise modified to catch or slow down the expansion cone 205 when it completes the extrusion of tubular member 210. In a preferred embodiment, wall thickness of the upper end portion 210d of the tubular member 210 is gradually tapered in order to gradually reduce the required radial expansion forces during the latter  
15           stages of the radial expansion process. In this manner, shock loading conditions during the latter stages of the radial expansion process are at least minimized.

          A shoe 215 is coupled to the lower portion 210a of the tubular member. The shoe 215 includes an upper portion 215a, an intermediate portion 215b, and lower  
20           portion 215c having a valveable fluid passage 220 that is preferably adapted to receive a plug, dart, or other similar element for controllably sealing the fluid passage 220. In this manner, the fluid passage 220 may be optimally sealed off by introducing a plug, dart and/or ball sealing elements into the fluid passage 220.

          The upper and lower portions, 215a and 215c, of the shoe 215 are preferably substantially tubular, and the intermediate portion 215b of the shoe is preferably at  
25           least partially folded inwardly. Furthermore, in a preferred embodiment, when the intermediate portion 215b of the shoe 215 is unfolded by the application of fluid pressure to the interior region 230 of the shoe, the inside and outside diameters of the intermediate portion are preferably both greater than the inside and outside diameters of the upper and lower portions, 215a and 215c. In this manner, the outer  
30           circumference of the intermediate portion 215b of the shoe 215 is preferably greater than the outside circumferences of the upper and lower portions, 215a and 215b, of the shoe.

          In a preferred embodiment, the shoe 215 further includes one or more through and side outlet ports in fluidic communication with the fluid passage 220. In this

manner, the shoe 215 optimally injects hardenable fluidic sealing material into the region outside the shoe 215 and tubular member 210.

In an alternative embodiment, the flow passage 220 is omitted.

5 A support member 225 having fluid passages 225a and 225b is coupled to the expansion cone 205 for supporting the apparatus 200. The fluid passage 225a is preferably fluidically coupled to the fluid passage 205a. In this manner, fluidic materials may be conveyed to and from the region 230 below the expansion cone 205 and above the bottom of the shoe 215. The fluid passage 225b is preferably fluidically coupled to the fluid passage 225a and includes a conventional control valve. In this manner, during  
10 placement of the apparatus 200 within the wellbore 100, surge pressures can be relieved by the fluid passage 225b. In a preferred embodiment, the support member 225 further includes one or more conventional centralizers (not illustrated) to help stabilize the apparatus 200.

During placement of the apparatus 200 within the wellbore 100, the fluid  
15 passage 225a is preferably selected to transport materials such as, for example, drilling mud or formation fluids at flow rates and pressures ranging from about 0 to 3,000 gallons/minute and 0 to 9,000 psi in order to minimize drag on the tubular member being run and to minimize surge pressures exerted on the wellbore 130 which could cause a loss of wellbore fluids and lead to hole collapse. During placement of the  
20 apparatus 200 within the wellbore 100, the fluid passage 225b is preferably selected to convey fluidic materials at flow rates and pressures ranging from about 0 to 3,000 gallons/minute and 0 to 9,000 psi in order to reduce the drag on the apparatus 200 during insertion into the new section 130 of the wellbore 100 and to minimize surge pressures on the new wellbore section 130.

25 A cup seal 235 is coupled to and supported by the support member 225. The cup seal 235 prevents foreign materials from entering the interior region of the tubular member 210 adjacent to the expansion cone 205. The cup seal 235 may be any number of conventional commercially available cup seals such as, for example, TP cups, or Selective Injection Packer (SIP) cups modified in accordance with the teachings of the  
30 present disclosure. In a preferred embodiment, the cup seal 235 is a SIP cup seal, available from Halliburton Energy Services in Dallas, TX in order to optimally block foreign material and contain a body of lubricant. In several alternative embodiments, the cup seal 235 may include a plurality of cup seals.

One or more sealing members 240 are preferably coupled to and supported by the exterior surface of the upper end portion 210d of the tubular member 210. The sealing members 240 preferably provide an overlapping joint between the lower end portion 115a of the casing 115 and the upper end portion 210d of the tubular member 210. The sealing members 240 may be any number of conventional commercially available seals such as, for example, lead, rubber, Teflon, or epoxy seals modified in accordance with the teachings of the present disclosure. In a preferred embodiment, the sealing members 240 are molded from Stratalock epoxy available from Halliburton Energy Services in Dallas, TX in order to optimally provide a load bearing interference fit between the upper end portion 210d of the tubular member 210 and the lower end portion 115a of the existing casing 115.

In a preferred embodiment, the sealing members 240 are selected to optimally provide a sufficient frictional force to support the expanded tubular member 210 from the existing casing 115. In a preferred embodiment, the frictional force optimally provided by the sealing members 240 ranges from about 1,000 to 1,000,000 lbf in order to optimally support the expanded tubular member 210.

In an alternative embodiment, the sealing members 240 are omitted from the upper end portion 210d of the tubular member 210, and a load bearing metal-to-metal interference fit is provided between upper end portion of the tubular member and the lower end portion 115a of the existing casing 115 by plastically deforming and radially expanding the tubular member into contact with the existing casing.

In a preferred embodiment, a quantity of lubricant 245 is provided in the annular region above the expansion cone 205 within the interior of the tubular member 210. In this manner, the extrusion of the tubular member 210 off of the expansion cone 205 is facilitated. The lubricant 245 may be any number of conventional commercially available lubricants such as, for example, Lubriplate, chlorine based lubricants, oil based lubricants or Climax 1500 Antisieze (3100). In a preferred embodiment, the lubricant 245 is Climax 1500 Antisieze (3100) available from Climax Lubricants and Equipment Co. in Houston, TX in order to optimally provide optimum lubrication to facilitate the expansion process.

In a preferred embodiment, the support member 225 is thoroughly cleaned prior to assembly to the remaining portions of the apparatus 200. In this manner, the introduction of foreign material into the apparatus 200 is minimized. This minimizes

the possibility of foreign material clogging the various flow passages and valves of the apparatus 200.

In a preferred embodiment, before or after positioning the apparatus 200 within the new section 130 of the wellbore 100, a couple of wellbore volumes are circulated in order to ensure that no foreign materials are located within the wellbore 100 that might clog up the various flow passages and valves of the apparatus 200 and to ensure that no foreign material interferes with the expansion process.

As illustrated in FIGS. 2 and 2e, in a preferred embodiment, during placement of the apparatus 200 within the wellbore 100, fluidic materials 250 within the wellbore that are displaced by the apparatus are at least partially conveyed through the fluid passages 220, 205a, 225a, and 225b. In this manner, surge pressures created by the placement of the apparatus within the wellbore 100 are reduced.

As illustrated in FIGS. 3, 3a, and 3b, the fluid passage 225b is then closed and a hardenable fluidic sealing material 255 is then pumped from a surface location into the fluid passages 225a and 205a. The material 255 then passes from the fluid passage 205a into the interior region 230 of the shoe 215 below the expansion cone 205. The material 255 then passes from the interior region 230 into the fluid passage 220. The material 255 then exits the apparatus 200 and fills an annular region 260 between the exterior of the tubular member 210 and the interior wall of the new section 130 of the wellbore 100. Continued pumping of the material 255 causes the material to fill up at least a portion of the annular region 260.

The material 255 is preferably pumped into the annular region 260 at pressures and flow rates ranging, for example, from about 0 to 5000 psi and 0 to 1,500 gallons/min, respectively. The optimum flow rate and operating pressures vary as a function of the casing and wellbore sizes, wellbore section length, available pumping equipment, and fluid properties of the fluidic material being pumped. The optimum flow rate and operating pressure are preferably determined using conventional empirical methods.

The hardenable fluidic sealing material 255 may be any number of conventional commercially available hardenable fluidic sealing materials such as, for example, slag mix, cement, latex or epoxy. In a preferred embodiment, the hardenable fluidic sealing material 255 is a blended cement prepared specifically for the particular well section being drilled from Halliburton Energy Services in Dallas, TX in order to provide optimal support for tubular member 210 while also maintaining optimum flow characteristics so as to minimize difficulties during the displacement of cement in the annular region 260.

The optimum blend of the blended cement is preferably determined using conventional empirical methods. In several alternative embodiments, the hardenable fluidic sealing material 255 is compressible before, during, or after curing.

5 The annular region 260 preferably is filled with the material 255 in sufficient quantities to ensure that, upon radial expansion of the tubular member 210, the annular region 260 of the new section 130 of the wellbore 100 will be filled with the material 255.

10 In an alternative embodiment, the injection of the material 255 into the annular region 260 is omitted, or is provided after the radial expansion of the tubular member 210.

As illustrated in FIGS. 4, 4a, and 4b, once the annular region 260 has been adequately filled with the material 255, a plug 265, or other similar device, is introduced into the fluid passage 220, thereby fluidically isolating the interior region 230 from the annular region 260. In a preferred embodiment, a non-hardenable fluidic material 270  
15 is then pumped into the interior region 230 causing the interior region to pressurize. In this manner, the interior region 230 of the expanded tubular member 210 will not contain significant amounts of the cured material 255. This also reduces and simplifies the cost of the entire process. Alternatively, the material 255 may be used during this phase of the process.

20 As illustrated in FIG. 5, in a preferred embodiment, the continued injection of the fluidic material 270 pressurizes the region 230 and unfolds the intermediate portion 215b of the shoe 215. In a preferred embodiment, the outside diameter of the unfolded intermediate portion 215b of the shoe 215 is greater than the outside diameter of the upper and lower portions, 215a and 215b, of the shoe. In a preferred embodiment, the  
25 inside and outside diameters of the unfolded intermediate portion 215b of the shoe 215 are greater than the inside and outside diameters, respectively, of the upper and lower portions, 215a and 215b, of the shoe. In a preferred embodiment, the inside diameter of the unfolded intermediate portion 215b of the shoe 215 is substantially equal to or greater than the inside diameter of the preexisting casing 115 in order to optimally  
30 facilitate the formation of a mono-diameter wellbore casing.

As illustrated in FIG. 6, in a preferred embodiment, the expansion cone 205 is then lowered into the unfolded intermediate portion 215b of the shoe 215. In a preferred embodiment, the expansion cone 205 is lowered into the unfolded intermediate portion 215b of the shoe 215 until the bottom of the expansion cone is

proximate the lower portion 215c of the shoe 215. In a preferred embodiment, during the lowering of the expansion cone 205 into the unfolded intermediate portion 215b of the shoe 215, the material 255 within the annular region 260 and/or the bottom of the wellbore section 130 maintains the shoe 215 in a substantially stationary position.

5           As illustrated in FIG. 7, in a preferred embodiment, the outside diameter of the expansion cone 205 is then increased. In a preferred embodiment, the outside diameter of the expansion cone 205 is increased as disclosed in U.S. patent nos. 5,348,095, and/or 6,012,523, the disclosures of which are incorporate herein by reference. In a preferred embodiment, the outside diameter of the radially expanded expansion cone 205 is  
10 substantially equal to the inside diameter of the preexisting wellbore casing 115.

In an alternative embodiment, the expansion cone 205 is not lowered into the radially expanded portion of the shoe 215 prior to being radially expanded. In this manner, the upper portion 210c of the shoe 210 may be radially expanded by the radial expansion of the expansion cone 205.

15           In another alternative embodiment, the expansion cone 205 is not radially expanded.

As illustrated in FIG. 8, in a preferred embodiment, a fluidic material 275 is then injected into the region 230 through the fluid passages 225a and 205a. In a preferred embodiment, once the interior region 230 becomes sufficiently pressurized, the upper  
20 portion 215a of the shoe 215 and the tubular member 210 are preferably plastically deformed, radially expanded, and extruded off of the expansion cone 205. Furthermore, in a preferred embodiment, during the end of the radial expansion process, the upper portion 210d of the tubular member and the lower portion of the preexisting casing 115 that overlap with one another are simultaneously plastically deformed and radially  
25 expanded. In this manner, a mono-diameter wellbore casing may be formed that includes the preexisting wellbore casing 115 and the radially expanded tubular member 210.

During the extrusion process, the expansion cone 205 may be raised out of the expanded portion of the tubular member 210. In a preferred embodiment, during the  
30 extrusion process, the expansion cone 205 is raised at approximately the same rate as the tubular member 210 is expanded in order to keep the tubular member 210 stationary relative to the new wellbore section 130. In this manner, an overlapping joint between the radially expanded tubular member 210 and the lower portion of the preexisting casing 115 may be optimally formed. In an alternative preferred

embodiment, the expansion cone 205 is maintained in a stationary position during the extrusion process thereby allowing the tubular member 210 to extrude off of the expansion cone 205 and into the new wellbore section 130 under the force of gravity and the operating pressure of the interior region 230.

5           In a preferred embodiment, when the upper end portion 210d of the tubular member 210 and the lower portion of the preexisting casing 115 that overlap with one another are plastically deformed and radially expanded by the expansion cone 205, the expansion cone 205 is displaced out of the wellbore 100 by both the operating pressure within the region 230 and a upwardly directed axial force applied to the tubular support  
10 member 225.

          The overlapping joint between the lower portion of the preexisting casing 115 and the radially expanded tubular member 210 preferably provides a gaseous and fluidic seal. In a particularly preferred embodiment, the sealing members 245 optimally provide a fluidic and gaseous seal in the overlapping joint. In an alternative  
15 embodiment, the sealing members 245 are omitted.

          In a preferred embodiment, the operating pressure and flow rate of the fluidic material 275 is controllably ramped down when the expansion cone 205 reaches the upper end portion 210d of the tubular member 210. In this manner, the sudden release of pressure caused by the complete extrusion of the tubular member 210 off of the  
20 expansion cone 205 can be minimized. In a preferred embodiment, the operating pressure is reduced in a substantially linear fashion from 100% to about 10% during the end of the extrusion process beginning when the expansion cone 205 is within about 5 feet from completion of the extrusion process.

          Alternatively, or in combination, the wall thickness of the upper end portion  
25 210d of the tubular member is tapered in order to gradually reduce the required operating pressure for plastically deforming and radially expanding the upper end portion of the tubular member. In this manner, shock loading of the apparatus is at least reduced.

          Alternatively, or in combination, a shock absorber is provided in the support  
30 member 225 in order to absorb the shock caused by the sudden release of pressure. The shock absorber may comprise, for example, any conventional commercially available shock absorber, bumper sub, or jars adapted for use in wellbore operations.



Alternatively, or in combination, an expansion cone catching structure is provided in the upper end portion 210d of the tubular member 210 in order to catch or at least decelerate the expansion cone 205.

In a preferred embodiment, the apparatus 200 is adapted to minimize tensile, burst, and friction effects upon the tubular member 210 during the expansion process. These effects will be depend upon the geometry of the expansion cone 205, the material composition of the tubular member 210 and expansion cone 205, the inner diameter of the tubular member 210, the wall thickness of the tubular member 210, the type of lubricant, and the yield strength of the tubular member 210. In general, the thicker the wall thickness, the smaller the inner diameter, and the greater the yield strength of the tubular member 210, then the greater the operating pressures required to extrude the tubular member 210 off of the expansion cone 205.

For typical tubular members 210, the extrusion of the tubular member 210 off of the expansion cone 205 will begin when the pressure of the interior region 230 reaches, for example, approximately 500 to 9,000 psi.

During the extrusion process, the expansion cone 205 may be raised out of the expanded portion of the tubular member 210 at rates ranging, for example, from about 0 to 5 ft/sec. In a preferred embodiment, during the extrusion process, the expansion cone 205 is raised out of the expanded portion of the tubular member 210 at rates ranging from about 0 to 2 ft/sec in order to minimize the time required for the expansion process while also permitting easy control of the expansion process.

As illustrated in FIG. 9, once the extrusion process is completed, the expansion cone 205 is removed from the wellbore 100. In a preferred embodiment, either before or after the removal of the expansion cone 205, the integrity of the fluidic seal of the overlapping joint between the upper end portion 210d of the tubular member 210 and the lower end portion 115a of the preexisting wellbore casing 115 is tested using conventional methods.

In a preferred embodiment, if the fluidic seal of the overlapping joint between the upper end portion 210d of the tubular member 210 and the lower end portion 115a of the casing 115 is satisfactory, then any uncured portion of the material 255 within the expanded tubular member 210 is then removed in a conventional manner such as, for example, circulating the uncured material out of the interior of the expanded tubular member 210. The expansion cone 205 is then pulled out of the wellbore section 130 and a drill bit or mill is used in combination with a conventional drilling assembly

to drill out any hardened material 255 within the tubular member 210. In a preferred embodiment, the material 255 within the annular region 260 is then allowed to fully cure.

5 As illustrated in FIG. 10, the bottom portion 215c of the shoe 215 may then be removed by drilling out the bottom portion of the shoe using conventional drilling methods. The wellbore 100 may then be extended in a conventional manner using a conventional drilling assembly. In a preferred embodiment, the inside diameter of the extended portion of the wellbore 100 is greater than the inside diameter of the radially expanded shoe 215.

10 As illustrated in FIG. 11, the method of FIGS. 1-10 may be repeatedly performed in order to provide a mono-diameter wellbore casing that includes overlapping wellbore casings 115 and 210a-210e. The wellbore casing 115, and 210a-210e preferably include outer annular layers of fluidic sealing material. Alternatively, the outer annular layers of fluidic sealing material may be omitted. In this manner, a mono-diameter wellbore casing may be formed within the subterranean formation that extends for tens of  
15 thousands of feet. More generally still, the teachings of FIGS. 1-11 may be used to form a mono-diameter wellbore casing, a pipeline, a structural support, or a tunnel within a subterranean formation at any orientation from the vertical to the horizontal.

In a preferred embodiment, the formation of a mono-diameter wellbore casing,  
20 as illustrated in FIGS. 1-11, is further provided as disclosed in one or more of the following: (1) U.S. patent application serial no. 09/454,139, attorney docket no. 25791.03.02, filed on 12/3/1999, (2) U.S. patent application serial no. 09/510,913, attorney docket no. 25791.7.02, filed on 2/23/2000, (3) U.S. patent application serial no. 09/502,350, attorney docket no. 25791.8.02, filed on 2/10/2000, (4) U.S. patent  
25 application serial no. 09/440,338, attorney docket no. 25791.9.02, filed on 11/15/1999, (5) U.S. patent application serial no. 09/523,460, attorney docket no. 25791.11.02, filed on 3/10/2000, (6) U.S. patent application serial no. 09/512,895, attorney docket no. 25791.12.02, filed on 2/24/2000, (7) U.S. patent application serial no. 09/511,941, attorney docket no. 25791.16.02, filed on 2/24/2000, (8) U.S. patent application serial no.  
30 09/588,946, attorney docket no. 25791.17.02, filed on 6/7/2000, (9) U.S. patent application serial no. 09/559,122, attorney docket no. 25791.23.02, filed on 4/26/2000, (10) PCT patent application serial no. PCT/US00/18635, attorney docket no. 25791.25.02, filed on 7/9/2000, (11) U.S. provisional patent application serial no. 60/162,671, attorney docket no. 25791.27, filed on 11/1/1999, (12) U.S. provisional

patent application serial no. 60/154,047, attorney docket no. 25791.29, filed on 9/16/1999, (13) U.S. provisional patent application serial no. 60/159,082, attorney docket no. 25791.34, filed on 10/12/1999, (14) U.S. provisional patent application serial no. 60/159,039, attorney docket no. 25791.36, filed on 10/12/1999, (15) U.S. provisional  
5 patent application serial no. 60/159,033, attorney docket no. 25791.37, filed on 10/12/1999, (16) U.S. provisional patent application serial no. 60/212,359, attorney docket no. 25791.38, filed on 6/19/2000, (17) U.S. provisional patent application serial no. 60/165,228, attorney docket no. 25791.39, filed on 11/12/1999, (18) U.S. provisional patent application serial no. 60/221,443, attorney docket no. 25791.45, filed on  
10 7/28/2000, (19) U.S. provisional patent application serial no. 60/221,645, attorney docket no. 25791.46, filed on 7/28/2000, (20) U.S. provisional patent application serial no. 60/233,638, attorney docket no. 25791.47, filed on 9/18/2000, (21) U.S. provisional patent application serial no. 60/237,334, attorney docket no. 25791.48, filed on 10/2/2000, and (22) U.S. provisional patent application serial no. 60/262,434, attorney  
15 docket no. 25791.51, filed on 1/17/2001, the disclosures of which are incorporated herein by reference.

Referring to FIGS. 12, 12a, 12b, 12c, and 12d, in an alternative embodiment, an apparatus 300 for forming a mono-diameter wellbore casing is positioned within the wellbore casing 115 that is substantially identical in design and operation to the  
20 apparatus 200 except that a shoe 305 is substituted for the shoe 215.

In a preferred embodiment, the shoe 305 includes an upper portion 305a, an intermediate portion 305b, and a lower portion 305c having a valveable fluid passage 310 that is preferably adapted to receive a plug, dart, or other similar element for controllably sealing the fluid passage 310. In this manner, the fluid passage 310 may be  
25 optimally sealed off by introducing a plug, dart and/or ball sealing elements into the fluid passage 310.

The upper and lower portions, 305a and 305c, of the shoe 305 are preferably substantially tubular, and the intermediate portion 305b of the shoe includes corrugations 305ba-305bh. Furthermore, in a preferred embodiment, when the  
30 intermediate portion 305b of the shoe 305 is radially expanded by the application of fluid pressure to the interior 315 of the shoe 305, the inside and outside diameters of the radially expanded intermediate portion are preferably both greater than the inside and outside diameters of the upper and lower portions, 305a and 305c. In this manner, the outer circumference of the intermediate portion 305b of the shoe 305 is preferably

greater than the outer circumferences of the upper and lower portions, 305a and 305c, of the shoe.

In a preferred embodiment, the shoe 305 further includes one or more through and side outlet ports in fluidic communication with the fluid passage 310. In this manner, the shoe 305 optimally injects hardenable fluidic sealing material into the region outside the shoe 305 and tubular member 210.

In an alternative embodiment, the flow passage 310 is omitted.

In a preferred embodiment, as illustrated in FIGS. 12 and 12d, during placement of the apparatus 300 within the wellbore 100, fluidic materials 250 within the wellbore that are displaced by the apparatus are conveyed through the fluid passages 310, 205a, 225a, and 225b. In this manner, surge pressures created by the placement of the apparatus within the wellbore 100 are reduced.

In a preferred embodiment, as illustrated in FIG. 13 and 13a, the fluid passage 225b is then closed and a hardenable fluidic sealing material 255 is then pumped from a surface location into the fluid passages 225a and 205a. The material 255 then passes from the fluid passage 205a into the interior region 315 of the shoe 305 below the expansion cone 205. The material 255 then passes from the interior region 315 into the fluid passage 310. The material 255 then exits the apparatus 300 and fills the annular region 260 between the exterior of the tubular member 210 and the interior wall of the new section 130 of the wellbore 100. Continued pumping of the material 255 causes the material to fill up at least a portion of the annular region 260.

The material 255 is preferably pumped into the annular region 260 at pressures and flow rates ranging, for example, from about 0 to 5000 psi and 0 to 1,500 gallons/min, respectively. The optimum flow rate and operating pressures vary as a function of the casing and wellbore sizes, wellbore section length, available pumping equipment, and fluid properties of the fluidic material being pumped. The optimum flow rate and operating pressure are preferably determined using conventional empirical methods.

The hardenable fluidic sealing material 255 may be any number of conventional commercially available hardenable fluidic sealing materials such as, for example, slag mix, cement, latex or epoxy. In a preferred embodiment, the hardenable fluidic sealing material 255 is a blended cement prepared specifically for the particular well section being drilled from Halliburton Energy Services in Dallas, TX in order to provide optimal support for tubular member 210 while also maintaining optimum flow characteristics so as to minimize difficulties during the displacement of cement in the annular region 260.

The optimum blend of the blended cement is preferably determined using conventional empirical methods. In several alternative embodiments, the hardenable fluidic sealing material 255 is compressible before, during, or after curing.

5 The annular region 260 preferably is filled with the material 255 in sufficient quantities to ensure that, upon radial expansion of the tubular member 210, the annular region 260 of the new section 130 of the wellbore 100 will be filled with the material 255.

In an alternative embodiment, the injection of the material 255 into the annular region 260 is omitted.

10 As illustrated in FIGS. 14 and 14a, once the annular region 260 has been adequately filled with the material 255, a plug 265, or other similar device, is introduced into the fluid passage 310, thereby fluidically isolating the interior region 315 from the annular region 260. In a preferred embodiment, a non-hardenable fluidic material 270 is then pumped into the interior region 315 causing the interior region to pressurize. In  
15 this manner, the interior region 315 will not contain significant amounts of the cured material 255. This also reduces and simplifies the cost of the entire process. Alternatively, the material 255 may be used during this phase of the process.

As illustrated in FIG. 15, in a preferred embodiment, the continued injection of the fluidic material 270 pressurizes the region 315 and unfolds the corrugations 305ba-  
20 305bh of the intermediate portion 305b of the shoe 305. In a preferred embodiment, the outside diameter of the unfolded intermediate portion 305b of the shoe 305 is greater than the outside diameter of the upper and lower portions, 305a and 305b, of the shoe. In a preferred embodiment, the inside and outside diameters of the unfolded intermediate portion 305b of the shoe 305 are greater than the inside and outside  
25 diameters, respectively, of the upper and lower portions, 305a and 305b, of the shoe. In a preferred embodiment, the inside diameter of the unfolded intermediate portion 305b of the shoe 305 is substantially equal to or greater than the inside diameter of the preexisting casing 305 in order to optimize the formation of a mono-diameter wellbore casing.

30 As illustrated in FIG. 16, in a preferred embodiment, the expansion cone 205 is then lowered into the unfolded intermediate portion 305b of the shoe 305. In a preferred embodiment, the expansion cone 205 is lowered into the unfolded intermediate portion 305b of the shoe 305 until the bottom of the expansion cone is proximate the lower portion 305c of the shoe 305. In a preferred embodiment, during

the lowering of the expansion cone 205 into the unfolded intermediate portion 305b of the shoe 305, the material 255 within the annular region 260 maintains the shoe 305 in a substantially stationary position.

As illustrated in FIG. 17, in a preferred embodiment, the outside diameter of the expansion cone 205 is then increased. In a preferred embodiment, the outside diameter of the expansion cone 205 is increased as disclosed in U.S. patent nos. 5,348,095, and/or 6,012,523, the disclosures of which are incorporate herein by reference. In a preferred embodiment, the outside diameter of the radially expanded expansion cone 205 is substantially equal to the inside diameter of the preexisting wellbore casing 115.

In an alternative embodiment, the expansion cone 205 is not lowered into the radially expanded portion of the shoe 305 prior to being radially expanded. In this manner, the upper portion 305c of the shoe 305 may be radially expanded by the radial expansion of the expansion cone 205.

In another alternative embodiment, the expansion cone 205 is not radially expanded.

As illustrated in FIG. 18, in a preferred embodiment, a fluidic material 275 is then injected into the region 315 through the fluid passages 225a and 205a. In a preferred embodiment, once the interior region 315 becomes sufficiently pressurized, the upper portion 305a of the shoe 305 and the tubular member 210 are preferably plastically deformed, radially expanded, and extruded off of the expansion cone 205. Furthermore, in a preferred embodiment, during the end of the radial expansion process, the upper portion 210d of the tubular member and the lower portion of the preexisting casing 115 that overlap with one another are simultaneously plastically deformed and radially expanded. In this manner, a mono-diameter wellbore casing may be formed that includes the preexisting wellbore casing 115 and the radially expanded tubular member 210.

During the extrusion process, the expansion cone 205 may be raised out of the expanded portion of the tubular member 210. In a preferred embodiment, during the extrusion process, the expansion cone 205 is raised at approximately the same rate as the tubular member 210 is expanded in order to keep the tubular member 210 stationary relative to the new wellbore section 130. In this manner, an overlapping joint between the radially expanded tubular member 210 and the lower portion of the preexisting casing 115 may be optimally formed. In an alternative preferred embodiment, the expansion cone 205 is maintained in a stationary position during the

extrusion process thereby allowing the tubular member 210 to extrude off of the expansion cone 205 and into the new wellbore section 130 under the force of gravity and the operating pressure of the interior region 230.

5 In a preferred embodiment, when the upper end portion 210d of the tubular member 210 and the lower portion of the preexisting casing 115 that overlap with one another are plastically deformed and radially expanded by the expansion cone 205, the expansion cone 205 is displaced out of the wellbore 100 by both the operating pressure within the region 230 and a upwardly directed axial force applied to the tubular support member 225.

10 The overlapping joint between the lower portion of the preexisting casing 115 and the radially expanded tubular member 210 preferably provides a gaseous and fluidic seal. In a particularly preferred embodiment, the sealing members 245 optimally provide a fluidic and gaseous seal in the overlapping joint. In an alternative embodiment, the sealing members 245 are omitted.

15 In a preferred embodiment, the operating pressure and flow rate of the fluidic material 275 is controllably ramped down when the expansion cone 205 reaches the upper end portion 210d of the tubular member 210. In this manner, the sudden release of pressure caused by the complete extrusion of the tubular member 210 off of the expansion cone 205 can be minimized. In a preferred embodiment, the operating  
20 pressure is reduced in a substantially linear fashion from 100% to about 10% during the end of the extrusion process beginning when the expansion cone 205 is within about 5 feet from completion of the extrusion process.

25 Alternatively, or in combination, the wall thickness of the upper end portion 210d of the tubular member is tapered in order to gradually reduce the required operating pressure for plastically deforming and radially expanding the upper end portion of the tubular member. In this manner, shock loading of the apparatus may be at least partially minimized.

30 Alternatively, or in combination, a shock absorber is provided in the support member 225 in order to absorb the shock caused by the sudden release of pressure. The shock absorber may comprise, for example, any conventional commercially available shock absorber adapted for use in wellbore operations.

Alternatively, or in combination, an expansion cone catching structure is provided in the upper end portion 210d of the tubular member 210 in order to catch or at least decelerate the expansion cone 205.

In a preferred embodiment, the apparatus 200 is adapted to minimize tensile, burst, and friction effects upon the tubular member 210 during the expansion process. These effects will be depend upon the geometry of the expansion cone 205, the material composition of the tubular member 210 and expansion cone 205, the inner diameter of  
5 the tubular member 210, the wall thickness of the tubular member 210, the type of lubricant, and the yield strength of the tubular member 210. In general, the thicker the wall thickness, the smaller the inner diameter, and the greater the yield strength of the tubular member 210, then the greater the operating pressures required to extrude the tubular member 210 off of the expansion cone 205.

10 For typical tubular members 210, the extrusion of the tubular member 210 off of the expansion cone 205 will begin when the pressure of the interior region 230 reaches, for example, approximately 500 to 9,000 psi.

During the extrusion process, the expansion cone 205 may be raised out of the expanded portion of the tubular member 210 at rates ranging, for example, from about  
15 0 to 5 ft/sec. In a preferred embodiment, during the extrusion process, the expansion cone 205 is raised out of the expanded portion of the tubular member 210 at rates ranging from about 0 to 2 ft/sec in order to minimize the time required for the expansion process while also permitting easy control of the expansion process.

As illustrated in FIG. 19, once the extrusion process is completed, the expansion  
20 cone 205 is removed from the wellbore 100. In a preferred embodiment, either before or after the removal of the expansion cone 205, the integrity of the fluidic seal of the overlapping joint between the upper end portion 210d of the tubular member 210 and the lower end portion 115a of the preexisting wellbore casing 115 is tested using conventional methods.

25 In a preferred embodiment, if the fluidic seal of the overlapping joint between the upper end portion 210d of the tubular member 210 and the lower end portion 115a of the casing 115 is satisfactory, then any uncured portion of the material 255 within the expanded tubular member 210 is then removed in a conventional manner such as, for example, circulating the uncured material out of the interior of the expanded  
30 tubular member 210. The expansion cone 205 is then pulled out of the wellbore section 130 and a drill bit or mill is used in combination with a conventional drilling assembly to drill out any hardened material 255 within the tubular member 210. In a preferred embodiment, the material 255 within the annular region 260 is then allowed to fully cure.



As illustrated in FIG. 20, the bottom portion 305c of the shoe 305 may then be removed by drilling out the bottom portion of the shoe using conventional drilling methods. The wellbore 100 may then be extended in a conventional manner using a conventional drilling assembly. In a preferred embodiment, the inside diameter of the extended portion of the wellbore is greater than the inside diameter of the radially expanded shoe 305.

The method of FIGS. 12-20 may be repeatedly performed in order to provide a mono-diameter wellbore casing that includes overlapping wellbore casings. The overlapping wellbore casing preferably include outer annular layers of fluidic sealing material. Alternatively, the outer annular layers of fluidic sealing material may be omitted. In this manner, a mono-diameter wellbore casing may be formed within the subterranean formation that extends for tens of thousands of feet. More generally still, the teachings of FIGS. 12-20 may be used to form a mono-diameter wellbore casing, a pipeline, a structural support, or a tunnel within a subterranean formation at any orientation from the vertical to the horizontal.

In a preferred embodiment, the formation of a mono-diameter wellbore casing, as illustrated in FIGS. 12-20, is further provided as disclosed in one or more of the following: (1) U.S. patent application serial no. 09/454,139, attorney docket no. 25791.03.02, filed on 12/3/1999, (2) U.S. patent application serial no. 09/510,913, attorney docket no. 25791.7.02, filed on 2/23/2000, (3) U.S. patent application serial no. 09/502,350, attorney docket no. 25791.8.02, filed on 2/10/2000, (4) U.S. patent application serial no. 09/440,338, attorney docket no. 25791.9.02, filed on 11/15/1999, (5) U.S. patent application serial no. 09/523,460, attorney docket no. 25791.11.02, filed on 3/10/2000, (6) U.S. patent application serial no. 09/512,895, attorney docket no. 25791.12.02, filed on 2/24/2000, (7) U.S. patent application serial no. 09/511,941, attorney docket no. 25791.16.02, filed on 2/24/2000, (8) U.S. patent application serial no. 09/588,946, attorney docket no. 25791.17.02, filed on 6/7/2000, (9) U.S. patent application serial no. 09/559,122, attorney docket no. 25791.23.02, filed on 4/26/2000, (10) PCT patent application serial no. PCT/US00/18635, attorney docket no. 25791.25.02, filed on 7/9/2000, (11) U.S. provisional patent application serial no. 60/162,671, attorney docket no. 25791.27, filed on 11/1/1999, (12) U.S. provisional patent application serial no. 60/154,047, attorney docket no. 25791.29, filed on 9/16/1999, (13) U.S. provisional patent application serial no. 60/159,082, attorney docket no. 25791.34, filed on 10/12/1999, (14) U.S. provisional patent application serial no.

60/159,039, attorney docket no. 25791.36, filed on 10/12/1999, (15) U.S. provisional patent application serial no. 60/159,033, attorney docket no. 25791.37, filed on 10/12/1999, (16) U.S. provisional patent application serial no. 60/212,359, attorney docket no. 25791.38, filed on 6/19/2000, (17) U.S. provisional patent application serial  
5 no. 60/165,228, attorney docket no. 25791.39, filed on 11/12/1999, (18) U.S. provisional patent application serial no. 60/221,443, attorney docket no. 25791.45, filed on 7/28/2000, (19) U.S. provisional patent application serial no. 60/221,645, attorney docket no. 25791.46, filed on 7/28/2000, (20) U.S. provisional patent application serial no. 60/233,638, attorney docket no. 25791.47, filed on 9/18/2000, (21) U.S. provisional  
10 patent application serial no. 60/237,334, attorney docket no. 25791.48, filed on 10/2/2000, and (22) U.S. provisional patent application serial no. 60/262,434, attorney docket no. 25791.51, filed on 1/17/2001, the disclosures of which are incorporated herein by reference.

15 In several alternative embodiments, the apparatus 200 and 300 are used to form and/or repair wellbore casings, pipelines, and/or structural supports.

In several alternative embodiments, the folded geometries of the shoes 215 and 305 are provided in accordance with the teachings of U.S. Patent Nos. 5,425,559 and/or 5,794,702, the disclosures of which are incorporated herein by reference.

20 An apparatus for forming a wellbore casing in a borehole located in a subterranean formation including a preexisting wellbore casing has been described that includes a support member including a first fluid passage, an expansion cone coupled to the support member including a second fluid passage fluidically coupled to the first fluid passage, an expandable tubular liner movably coupled to the expansion cone, and an expandable shoe coupled to the expandable tubular liner. In a preferred embodiment,  
25 the expansion cone is expandable. In a preferred embodiment, the expandable shoe includes a valveable fluid passage for controlling the flow of fluidic materials out of the expandable shoe. In a preferred embodiment, the expandable shoe includes: an expandable portion and a remaining portion, wherein the outer circumference of the expandable portion is greater than the outer circumference of the remaining portion. In  
30 a preferred embodiment, the expandable portion includes: one or more inward folds. In a preferred embodiment, the expandable portion includes: one or more corrugations. In a preferred embodiment, the expandable shoe includes: one or more inward folds. In a preferred embodiment, the expandable shoe includes: one or more corrugations.

A shoe has also been described that includes an upper annular portion, an intermediate annular portion, and a lower annular portion, wherein the intermediate annular portion has an outer circumference that is larger than the outer circumferences of the upper and lower annular portions. In a preferred embodiment, the lower annular portion includes a valveable fluid passage for controlling the flow of fluidic materials out of the shoe. In a preferred embodiment, the intermediate portion includes one or more inward folds. In a preferred embodiment, the intermediate portion includes one or more corrugations.

A method of forming a wellbore casing in a subterranean formation having a preexisting wellbore casing positioned in a borehole has also been described that includes installing a tubular liner, an expansion cone, and a shoe in the borehole, radially expanding at least a portion of the shoe by injecting a fluidic material into the shoe, and radially expanding at least a portion of the tubular liner by injecting a fluidic material into the borehole below the expansion cone. In a preferred embodiment, the method further includes radially expanding the expansion cone. In a preferred embodiment, the method further includes lowering the expansion cone into the radially expanded portion of the shoe, and radially expanding the expansion cone. In a preferred embodiment, the method further includes radially expanding at least a portion of the shoe and the tubular liner by injecting a fluidic material into the borehole below the radially expanded expansion cone. In a preferred embodiment, the method further includes injecting a hardenable fluidic sealing material into an annulus between the tubular liner and the borehole. In a preferred embodiment, the method further includes radially expanding at least a portion of the preexisting wellbore casing. In a preferred embodiment, the method further includes overlapping a portion of the radially expanded tubular liner with a portion of the preexisting wellbore casing. In a preferred embodiment, the inside diameter of the radially expanded tubular liner is substantially equal to the inside diameter of a nonoverlapping portion of the preexisting wellbore casing. In a preferred embodiment, the method further includes applying an axial force to the expansion cone. In a preferred embodiment, the inside diameter of the radially expanded shoe is greater than or equal to the inside diameter of the radially expanded tubular liner.

An apparatus for forming a wellbore casing in a subterranean formation having a preexisting wellbore casing positioned in a borehole has also been described that includes means for installing a tubular liner, an expansion cone, and a shoe in the

borehole, means for radially expanding at least a portion of the shoe, and means for radially expanding at least a portion of the tubular liner. In a preferred embodiment, the apparatus further includes means for radially expanding the expansion cone. In a preferred embodiment, the apparatus further includes means for lowering the

5 expansion cone into the radially expanded portion of the shoe, and means for radially expanding the expansion cone. In a preferred embodiment, the apparatus further includes means for injecting a fluidic material into the borehole below the radially expanded expansion cone. In a preferred embodiment, the apparatus further includes means for injecting a hardenable fluidic sealing material into an annulus between the

10 tubular liner and the borehole. In a preferred embodiment, the apparatus further includes means for radially expanding at least a portion of the preexisting wellbore casing. In a preferred embodiment, the apparatus further includes means for overlapping a portion of the radially expanded tubular liner with a portion of the preexisting wellbore casing. In a preferred embodiment, the inside diameter of the

15 radially expanded tubular liner is substantially equal to the inside diameter of a nonoverlapping portion of the preexisting wellbore casing. In a preferred embodiment, the apparatus further includes means for applying an axial force to the expansion cone. In a preferred embodiment, the inside diameter of the radially expanded shoe is greater than or equal to the inside diameter of the radially expanded tubular liner.

20 An apparatus for forming a wellbore casing within a subterranean formation including a preexisting wellbore casing positioned in a borehole has also been described that includes a tubular liner and means for radially expanding and coupling the tubular liner to an overlapping portion of the preexisting wellbore casing. The inside diameter of the radially expanded tubular liner is substantially equal to the inside diameter of a

25 non-overlapping portion of the preexisting wellbore casing.

A wellbore casing positioned in a borehole within a subterranean formation has also been described that includes a first wellbore casing and a second wellbore casing coupled to and overlapping with the first wellbore casing, wherein the second wellbore casing is coupled to the first wellbore casing by the process of: installing the second

30 wellbore casing, an expansion cone, and a shoe in the borehole, radially expanding at least a portion of the shoe by injecting a fluidic material into the shoe, and radially expanding at least a portion of the second wellbore casing by injecting a fluidic material into the borehole below the expansion cone. In a preferred embodiment, the process for forming the wellbore casing further includes radially expanding the expansion cone. In

a preferred embodiment, the process for forming the wellbore casing further includes lowering the expansion cone into the radially expanded portion of the shoe, and radially expanding the expansion cone. In a preferred embodiment, the process for forming the wellbore casing further includes radially expanding at least a portion of the shoe and  
5 the second wellbore casing by injecting a fluidic material into the borehole below the radially expanded expansion cone. In a preferred embodiment, the process for forming the wellbore casing further includes injecting a hardenable fluidic sealing material into an annulus between the second wellbore casing and the borehole. In a preferred  
10 embodiment, the process for forming the wellbore casing further includes radially expanding at least a portion of the first wellbore casing. In a preferred embodiment, the process for forming the wellbore casing further includes overlapping a portion of the radially expanded second wellbore casing with a portion of the first wellbore casing. In  
15 a preferred embodiment, the inside diameter of the radially expanded second wellbore casing is substantially equal to the inside diameter of a nonoverlapping portion of the first wellbore casing. In a preferred embodiment, the process for forming the wellbore casing further includes applying an axial force to the expansion cone. In a preferred  
embodiment, the inside diameter of the radially expanded shoe is greater than or equal to the inside diameter of the radially expanded second wellbore casing.

A method of forming a tubular structure in a subterranean formation having a  
20 preexisting tubular member positioned in a borehole has also been described that includes installing a tubular liner, an expansion cone, and a shoe in the borehole, radially expanding at least a portion of the shoe by injecting a fluidic material into the shoe, and radially expanding at least a portion of the tubular liner by injecting a fluidic  
25 material into the borehole below the expansion cone. In a preferred embodiment, the method further includes radially expanding the expansion cone. In a preferred embodiment, the method further includes lowering the expansion cone into the radially expanded portion of the shoe, and radially expanding the expansion cone. In a preferred  
30 embodiment, the method further includes radially expanding at least a portion of the shoe and the tubular liner by injecting a fluidic material into the borehole below the radially expanded expansion cone. In a preferred embodiment, the method further includes injecting a hardenable fluidic sealing material into an annulus between the  
tubular liner and the borehole. In a preferred embodiment, the method further includes radially expanding at least a portion of the preexisting tubular member. In a preferred  
embodiment, the method further includes overlapping a portion of the radially

expanded tubular liner with a portion of the preexisting tubular member. In a preferred embodiment, the inside diameter of the radially expanded tubular liner is substantially equal to the inside diameter of a nonoverlapping portion of the preexisting tubular member. In a preferred embodiment, the method further includes applying an axial force to the expansion cone. In a preferred embodiment, the inside diameter of the  
5 radially expanded shoe is greater than or equal to the inside diameter of the radially expanded tubular liner.

An apparatus for forming a tubular structure in a subterranean formation having a preexisting tubular member positioned in a borehole has also been described  
10 that includes means for installing a tubular liner, an expansion cone, and a shoe in the borehole, means for radially expanding at least a portion of the shoe, and means for radially expanding at least a portion of the tubular liner. In a preferred embodiment, the apparatus further includes means for radially expanding the expansion cone. In a preferred embodiment, the apparatus further includes means for lowering the  
15 expansion cone into the radially expanded portion of the shoe, and means for radially expanding the expansion cone. In a preferred embodiment, the apparatus further includes means for injecting a fluidic material into the borehole below the radially expanded expansion cone. In a preferred embodiment, the apparatus further includes means for injecting a hardenable fluidic sealing material into an annulus between the  
20 tubular liner and the borehole. In a preferred embodiment, the apparatus further includes means for radially expanding at least a portion of the preexisting tubular member. In a preferred embodiment, the apparatus further includes means for overlapping a portion of the radially expanded tubular liner with a portion of the preexisting tubular member. In a preferred embodiment, the inside diameter of the  
25 radially expanded tubular liner is substantially equal to the inside diameter of a nonoverlapping portion of the preexisting tubular member. In a preferred embodiment, the apparatus further includes means for applying an axial force to the expansion cone. In a preferred embodiment, the inside diameter of the radially expanded shoe is greater than or equal to the inside diameter of the radially expanded tubular liner.

30 An apparatus for forming a tubular structure within a subterranean formation including a preexisting tubular member positioned in a borehole has also been described that includes a tubular liner and means for radially expanding and coupling the tubular liner to an overlapping portion of the preexisting tubular member. The inside diameter

of the radially expanded tubular liner is substantially equal to the inside diameter of a non-overlapping portion of the preexisting tubular member.

A tubular structure positioned in a borehole within a subterranean formation has also been described that includes a first tubular member and a second tubular member coupled to and overlapping with the first tubular member, wherein the second tubular member is coupled to the first tubular member by the process of: installing the second tubular member, an expansion cone, and a shoe in the borehole, radially expanding at least a portion of the shoe by injecting a fluidic material into the shoe, and radially expanding at least a portion of the second tubular member by injecting a fluidic material into the borehole below the expansion cone. In a preferred embodiment, the process for forming the tubular structure further includes radially expanding the expansion cone. In a preferred embodiment, the process for forming the tubular structure further includes lowering the expansion cone into the radially expanded portion of the shoe, and radially expanding the expansion cone. In a preferred embodiment, the process for forming the tubular structure further includes radially expanding at least a portion of the shoe and the second tubular member by injecting a fluidic material into the borehole below the radially expanded expansion cone. In a preferred embodiment, the process for forming the tubular structure further includes injecting a hardenable fluidic sealing material into an annulus between the second tubular member and the borehole. In a preferred embodiment, the process for forming the tubular structure further includes radially expanding at least a portion of the first tubular member. In a preferred embodiment, the process for forming the tubular structure further includes overlapping a portion of the radially expanded second tubular member with a portion of the first tubular member. In a preferred embodiment, the inside diameter of the radially expanded second tubular member is substantially equal to the inside diameter of a nonoverlapping portion of the first tubular member. In a preferred embodiment, the process for forming the tubular structure further includes applying an axial force to the expansion cone. In a preferred embodiment, the inside diameter of the radially expanded shoe is greater than or equal to the inside diameter of the radially expanded second tubular member.

Although illustrative embodiments of the invention have been shown and described, a wide range of modification, changes and substitution is contemplated in the foregoing disclosure. In some instances, some features of the present invention may be employed without a corresponding use of the other features. Accordingly, it is

appropriate that the appended claims be construed broadly and in a manner consistent with the scope of the invention.



## Claims

What is claimed is:

- 1 1. An apparatus for forming a wellbore casing in a borehole located in a  
2 subterranean formation including a preexisting wellbore casing, comprising:  
3 a support member including a first fluid passage;  
4 an expansion cone coupled to the support member including a second fluid  
5 passage fluidicly coupled to the first fluid passage;  
6 an expandable tubular liner movably coupled to the expansion cone; and  
7 an expandable shoe coupled to the expandable tubular liner.
- 1 2. The apparatus of claim 1, wherein the expansion cone is expandable.
- 1 3. The apparatus of claim 1, wherein the expandable shoe includes a valveable fluid  
2 passage for controlling the flow of fluidic materials out of the expandable shoe.
- 1 4. The apparatus of claim 1, wherein the expandable shoe includes:  
2 an expandable portion; and  
3 a remaining portion coupled to the expandable portion;  
4 wherein the outer circumference of the expandable portion is greater than the  
5 outer circumference of the remaining portion.
- 1 5. The apparatus of claim 4, wherein the expandable portion includes:  
2 one or more inward folds.
- 1 6. The apparatus of claim 4, wherein the expandable portion includes:  
2 one or more corrugations.
- 1 7. The apparatus of claim 1, wherein the expandable shoe includes:  
2 one or more inward folds.
- 1 8. The apparatus of claim 1, wherein the expandable shoe includes:  
2 one or more corrugations.

- 1 9. A shoe, comprising:  
2 an upper annular portion;  
3 an intermediate annular portion coupled to the upper annular portion; and  
4 a lower annular portion coupled to the intermediate portion;  
5 wherein the intermediate annular portion has an outer circumference that is  
6 larger than the outer circumferences of the upper and lower annular  
7 portions.
- 1 10. The shoe of claim 9, wherein the lower annular portion includes a valveable fluid  
2 passage for controlling the flow of fluidic materials out of the shoe.
- 1 11. The shoe of claim 9, wherein the intermediate portion includes:  
2 one or more inward folds.
- 1 12. The shoe of claim 9, wherein the intermediate portion includes:  
2 one or more corrugations.
- 1 13. A method of forming a wellbore casing in a subterranean formation having a  
2 preexisting wellbore casing positioned in a borehole, comprising:  
3 installing a tubular liner, an expansion cone, and a shoe in the borehole;  
4 radially expanding at least a portion of the shoe by injecting a fluidic material  
5 into the shoe; and  
6 radially expanding at least a portion of the tubular liner by injecting a fluidic  
7 material into the borehole below the expansion cone.
- 1 14. The method of claim 13, further comprising:  
2 radially expanding the expansion cone.
- 1 15. The method of claim 13, further comprising:  
2 lowering the expansion cone into the radially expanded portion of the shoe; and  
3 radially expanding the expansion cone.
- 1 16. The method of claim 15, further comprising:

2 radially expanding at least a portion of the shoe and the tubular liner by  
3 injecting a fluidic material into the borehole below the radially expanded  
4 expansion cone.

1 17. The method of claim 13, further comprising:  
2 injecting a hardenable fluidic sealing material into an annulus between the  
3 tubular liner and the borehole.

1 18. The method of claim 13, further comprising:  
2 radially expanding at least a portion of the preexisting wellbore casing.

1 19. The method of claim 18, further comprising:  
2 overlapping a portion of the radially expanded tubular liner with a portion of the  
3 preexisting wellbore casing.

1 20. The method of claim 19, wherein the inside diameter of the radially expanded  
2 tubular liner is substantially equal to or greater than the inside diameter of a  
3 nonoverlapping portion of the preexisting wellbore casing.

1 21. The method of claim 18, further comprising:  
2 applying an axial force to the expansion cone.

1 22. The method of claim 13, wherein the inside diameter of the radially expanded  
2 shoe is greater than or substantially equal to the inside diameter of the radially  
3 expanded tubular liner.

1 23. An apparatus for forming a wellbore casing in a subterranean formation having  
2 a preexisting wellbore casing positioned in a borehole, comprising:  
3 means for installing a tubular liner, an expansion cone, and a shoe in the  
4 borehole;  
5 means for radially expanding at least a portion of the shoe by injecting a fluidic  
6 material into the shoe; and  
7 means for radially expanding at least a portion of the tubular liner by injecting a  
8 fluidic material into the borehole below the expansion cone.

- 1 24. The apparatus of claim 23, further comprising:  
2 means for radially expanding the expansion cone.
- 1 25. The apparatus of claim 23, further comprising:  
2 means for lowering the expansion cone into the radially expanded portion of the  
3 shoe; and  
4 means for radially expanding the expansion cone.
- 1 26. The apparatus of claim 25, further comprising:  
2 means for injecting a fluidic material into the borehole below the radially  
3 expanded expansion cone.
- 1 27. The apparatus of claim 23, further comprising:  
2 means for injecting a hardenable fluidic sealing material into an annulus  
3 between the tubular liner and the borehole.
- 1 28. The apparatus of claim 23, further comprising:  
2 means for radially expanding at least a portion of the preexisting wellbore  
3 casing.
- 1 29. The apparatus of claim 28, further comprising:  
2 means for overlapping a portion of the radially expanded tubular liner with a  
3 portion of the preexisting wellbore casing.
- 1 30. The apparatus of claim 29, wherein the inside diameter of the radially expanded  
2 tubular liner is substantially equal to the inside diameter of a nonoverlapping portion of  
3 the preexisting wellbore casing.
- 1 31. The apparatus of claim 28, further comprising:  
2 means for applying an axial force to the expansion cone.

1 32. The apparatus of claim 23, wherein the inside diameter of the radially expanded  
2 shoe is greater than or substantially equal to the inside diameter of the radially  
3 expanded tubular liner.

1 33. An apparatus for forming a wellbore casing within a subterranean formation  
2 including a preexisting wellbore casing positioned in a borehole, comprising:  
3 a tubular liner; and  
4 means for radially expanding and coupling the tubular liner to an overlapping  
5 portion of the preexisting wellbore casing;  
6 wherein the inside diameter of the radially expanded tubular liner is  
7 substantially equal to the inside diameter of a non-overlapping portion of  
8 the preexisting wellbore casing.

1 34. A wellbore casing positioned in a borehole within a subterranean formation,  
2 comprising:  
3 a first wellbore casing; and  
4 a second wellbore casing coupled to and overlapping with the first wellbore  
5 casing;  
6 wherein the second wellbore casing is coupled to the first wellbore casing by the  
7 process of:  
8 installing the second wellbore casing, an expansion cone, and a shoe in  
9 the borehole;  
10 radially expanding at least a portion of the shoe by injecting a fluidic  
11 material into the shoe; and  
12 radially expanding at least a portion of the second wellbore casing by  
13 injecting a fluidic material into the borehole below the expansion  
14 cone.

1 35. The wellbore casing of claim 34, wherein the process further comprises:  
2 radially expanding the expansion cone.

1 36. The wellbore casing of claim 34, wherein the process further comprises:  
2 lowering the expansion cone into the radially expanded portion of the shoe; and  
3 radially expanding the expansion cone.

- 1 37. The wellbore casing of claim 36, wherein the process further comprises:  
2 radially expanding at least a portion of the shoe and the second wellbore casing  
3 by injecting a fluidic material into the borehole below the radially  
4 expanded expansion cone.
- 1 38. The wellbore casing of claim 34, wherein the process further comprises:  
2 injecting a hardenable fluidic sealing material into an annulus between the  
3 second wellbore casing and the borehole.
- 1 39. The wellbore casing of claim 34, wherein the process further comprises:  
2 radially expanding at least a portion of the first wellbore casing.
- 1 40. The wellbore casing of claim 39, wherein the process further comprises:  
2 overlapping a portion of the radially expanded second wellbore casing with a  
3 portion of the first wellbore casing.
- 1 41. The wellbore casing of claim 40, wherein the inside diameter of the radially  
2 expanded second wellbore casing is substantially equal to the inside diameter of a  
3 nonoverlapping portion of the first wellbore casing.
- 1 42. The wellbore casing of claim 39, wherein the process further comprises:  
2 applying an axial force to the expansion cone.
- 1 43. The wellbore casing of claim 34, wherein the inside diameter of the radially  
2 expanded shoe is greater than or substantially equal to the inside diameter of the  
3 radially expanded second wellbore casing.
- 1 44. A method of forming a tubular structure in a subterranean formation having a  
2 preexisting tubular member positioned in a borehole, comprising:  
3 installing a tubular liner, an expansion cone, and a shoe in the borehole;  
4 radially expanding at least a portion of the shoe by injecting a fluidic material  
5 into the shoe; and

6 radially expanding at least a portion of the tubular liner by injecting a fluidic  
7 material into the borehole below the expansion cone.

1 45. The method of claim 44, further comprising:  
2 radially expanding the expansion cone.

1 46. The method of claim 44, further comprising:  
2 lowering the expansion cone into the radially expanded portion of the shoe; and  
3 radially expanding the expansion cone.

1 47. The method of claim 46, further comprising:  
2 radially expanding at least a portion of the shoe and the tubular liner by  
3 injecting a fluidic material into the borehole below the radially expanded  
4 expansion cone.

1 48. The method of claim 44, further comprising:  
2 injecting a hardenable fluidic sealing material into an annulus between the  
3 tubular liner and the borehole.

1 49. The method of claim 44, further comprising:  
2 radially expanding at least a portion of the preexisting tubular member.

1 50. The method of claim 49, further comprising:  
2 overlapping a portion of the radially expanded tubular liner with a portion of the  
3 preexisting tubular member to provide a load bearing interface and a  
4 fluidic seal.

1 51. The method of claim 50, wherein the inside diameter of the radially expanded  
2 tubular liner is substantially equal to the inside diameter of a nonoverlapping portion of  
3 the preexisting tubular member.

1 52. The method of claim 49, further comprising:  
2 applying an axial force to the expansion cone.

1 53. The method of claim 44, wherein the inside diameter of the radially expanded  
2 shoe is greater than or substantially equal to the inside diameter of the radially  
3 expanded tubular liner.

1 54. An apparatus for forming a tubular structure in a subterranean formation  
2 having a preexisting tubular member positioned in a borehole, comprising:  
3 means for installing a tubular liner, an expansion cone, and a shoe in the  
4 borehole;  
5 means for radially expanding at least a portion of the shoe; and  
6 means for radially expanding at least a portion of the tubular liner.

1 55. The apparatus of claim 54, further comprising:  
2 means for radially expanding the expansion cone.

1 56. The apparatus of claim 54, further comprising:  
2 means for lowering the expansion cone into the radially expanded portion of the  
3 shoe; and  
4 means for radially expanding the expansion cone.

1 57. The apparatus of claim 56, further comprising:  
2 means for injecting a fluidic material into the borehole below the radially  
3 expanded expansion cone.

1 58. The apparatus of claim 54, further comprising:  
2 means for injecting a hardenable fluidic sealing material into an annulus  
3 between the tubular liner and the borehole.

1 59. The apparatus of claim 54, further comprising:  
2 means for radially expanding at least a portion of the preexisting tubular  
3 member.

1 60. The apparatus of claim 59, further comprising:



2 means for overlapping a portion of the radially expanded tubular liner with a  
3 portion of the preexisting tubular member to provide a load bearing  
4 interface and a fluidic seal.

1 61. The apparatus of claim 60, wherein the inside diameter of the radially expanded  
2 tubular liner is substantially equal to the inside diameter of a nonoverlapping portion of  
3 the preexisting tubular member.

1 62. The apparatus of claim 59, further comprising:  
2 means for applying an axial force to the expansion cone.

1 63. The apparatus of claim 54, wherein the inside diameter of the radially expanded  
2 shoe is greater than or substantially equal to the inside diameter of the radially  
3 expanded tubular liner.

1 64. An apparatus for forming a tubular structure within a subterranean formation  
2 including a preexisting tubular member positioned in a borehole, comprising:  
3 a tubular liner; and  
4 means for radially expanding and coupling the tubular liner to an overlapping  
5 portion of the preexisting tubular member;  
6 wherein the inside diameter of the radially expanded tubular liner is  
7 substantially equal to the inside diameter of a non-overlapping portion of  
8 the preexisting tubular member.

1 65. A tubular structure positioned in a borehole within a subterranean formation,  
2 comprising:  
3 a first tubular member; and  
4 a second tubular member coupled to and overlapping with the first tubular  
5 member;  
6 wherein the second tubular member is coupled to the first tubular member by  
7 the process of:  
8 installing the second tubular member, an expansion cone, and a shoe in  
9 the borehole;

10                   radially expanding at least a portion of the shoe by injecting a fluidic  
11                   material into the shoe; and  
12                   radially expanding at least a portion of the second tubular member by  
13                   injecting a fluidic material into the borehole below the expansion  
14                   cone.

1   66.    The tubular structure of claim 65, wherein the process further comprises:  
2           radially expanding the expansion cone.

1   67.    The tubular structure of claim 65, wherein the process further comprises:  
2           lowering the expansion cone into the radially expanded portion of the shoe; and  
3           radially expanding the expansion cone.

1   68.    The tubular structure of claim 67, wherein the process further comprises:  
2           radially expanding at least a portion of the shoe and the second tubular member  
3                   by injecting a fluidic material into the borehole below the radially  
4           expanded expansion cone.

1   69.    The tubular structure of claim 65, wherein the process further comprises:  
2           injecting a hardenable fluidic sealing material into an annulus between the  
3                   second tubular member and the borehole.

1   70.    The tubular structure of claim 65, wherein the process further comprises:  
2           radially expanding at least a portion of the first tubular member.

1   71.    The tubular structure of claim 70, wherein the process further comprises:  
2           overlapping a portion of the radially expanded second tubular member with a  
3                   portion of the first tubular member.

1   72.    The tubular structure of claim 71, wherein the inside diameter of the radially  
2           expanded second tubular member is substantially equal to the inside diameter of a  
3           nonoverlapping portion of the first tubular member.

1 73. The tubular structure of claim 70, wherein the process further comprises:  
2 applying an axial force to the expansion cone.

1 74. The tubular structure of claim 65, wherein the inside diameter of the radially  
2 expanded shoe is greater than or substantially equal to the inside diameter of the  
3 radially expanded second tubular member.

1 75. An apparatus for forming a wellbore casing in a borehole located in a  
2 subterranean formation including a preexisting wellbore casing, comprising:  
3 a support member including a first fluid passage;  
4 an expandable expansion cone coupled to the support member including a second  
5 fluid passage fluidically coupled to the first fluid passage;  
6 an expandable tubular liner movably coupled to the expansion cone; and  
7 an expandable shoe coupled to the expandable tubular liner comprising:  
8 a valveable fluid passage for controlling the flow of fluidic materials out of  
9 the expandable shoe;  
10 an expandable portion including one or more inward folds; and  
11 a remaining portion coupled to the expandable portion;  
12 wherein the outer circumference of the expandable portion is greater  
13 than the outer circumference of the remaining portion.

1 76. A shoe, comprising:  
2 an upper annular portion;  
3 an intermediate annular portion coupled to the upper annular portion including  
4 one or more inward folds; and  
5 a lower annular portion coupled to the intermediate portion including a  
6 valveable fluid passage for controlling the flow of fluidic materials out of  
7 the shoe;  
8 wherein the intermediate annular portion has an outer circumference that is  
9 larger than the outer circumferences of the upper and lower annular  
10 portions.

1 77. A method of forming a wellbore casing in a subterranean formation having a  
2 preexisting wellbore casing positioned in a borehole, comprising:

3 installing a tubular liner, an expansion cone, and a shoe in the borehole;  
4 radially expanding at least a portion of the shoe by injecting a fluidic material  
5 into the shoe;  
6 lowering the expansion cone into the radially expanded portion of the shoe;  
7 radially expanding the expansion cone;  
8 radially expanding at least a portion of the tubular liner by injecting a fluidic  
9 material into the borehole below the expansion cone; and  
10 overlapping a portion of the radially expanded tubular liner with a portion of the  
11 preexisting wellbore casing;  
12 wherein the inside diameter of the radially expanded shoe is greater than or  
13 substantially equal to the inside diameter of the radially expanded  
14 tubular liner; and  
15 wherein the inside diameter of the radially expanded tubular liner is  
16 substantially equal to or greater than the inside diameter of a  
17 nonoverlapping portion of the preexisting wellbore casing.

1 78. An apparatus for forming a wellbore casing in a subterranean formation having  
2 a preexisting wellbore casing positioned in a borehole, comprising:  
3 means for installing a tubular liner, an expansion cone, and a shoe in the  
4 borehole;  
5 means for radially expanding at least a portion of the shoe by injecting a fluidic  
6 material into the shoe;  
7 means for lowering the expansion cone into the radially expanded portion of the  
8 shoe;  
9 means for radially expanding the expansion cone;  
10 means for radially expanding at least a portion of the tubular liner by injecting a  
11 fluidic material into the borehole below the radially expanded expansion  
12 cone;  
13 means for radially expanding at least a portion of the preexisting wellbore  
14 casing; and  
15 means for overlapping a portion of the radially expanded tubular liner with a  
16 portion of the preexisting wellbore casing;

17 wherein the inside diameter of the radially expanded shoe is greater than or  
18 substantially equal to the inside diameter of the radially expanded  
19 tubular liner; and  
20 wherein the inside diameter of the radially expanded tubular liner is  
21 substantially equal to the inside diameter of a nonoverlapping portion of  
22 the preexisting wellbore casing.

1 79. A wellbore casing positioned in a borehole within a subterranean formation,  
2 comprising:  
3 a first wellbore casing; and  
4 a second wellbore casing coupled to and overlapping with the first wellbore  
5 casing;  
6 wherein the second wellbore casing is coupled to the first wellbore casing by the  
7 process of:  
8 installing the second wellbore casing, an expansion cone, and a shoe in  
9 the borehole;  
10 radially expanding at least a portion of the shoe by injecting a fluidic  
11 material into the shoe;  
12 lowering the expansion cone into the radially expanded portion of the  
13 shoe;  
14 radially expanding the expansion cone;  
15 radially expanding at least a portion of the second wellbore casing by  
16 injecting a fluidic material into the borehole below the radially  
17 expanded expansion cone; and  
18 overlapping a portion of the radially expanded second wellbore casing  
19 with a portion of the first wellbore casing;  
20 wherein the inside diameter of the radially expanded shoe is greater than  
21 or substantially equal to the inside diameter of the radially  
22 expanded second wellbore casing; and  
23 wherein the inside diameter of the radially expanded second wellbore  
24 casing is substantially equal to the inside diameter of a  
25 nonoverlapping portion of the first wellbore casing.

.25791.50.02

1 80. A method of forming a tubular structure in a subterranean formation having a  
2 preexisting tubular member positioned in a borehole, comprising:  
3 installing a tubular liner, an expansion cone, and a shoe in the borehole;  
4 radially expanding at least a portion of the shoe by injecting a fluidic material  
5 into the shoe;  
6 lowering the expansion cone into the radially expanded portion of the shoe;  
7 radially expanding the expansion cone;  
8 radially expanding at least a portion of the tubular liner by injecting a fluidic  
9 material into the borehole below the radially expanded expansion cone;  
10 and  
11 overlapping a portion of the radially expanded tubular liner with a portion of the  
12 preexisting tubular member to provide a load bearing interface and a  
13 fluidic seal;  
14 wherein the inside diameter of the radially expanded shoe is greater than or  
15 substantially equal to the inside diameter of the radially expanded  
16 tubular liner; and  
17 wherein the inside diameter of the radially expanded tubular liner is  
18 substantially equal to the inside diameter of a nonoverlapping portion of  
19 the preexisting tubular member.

1 81. An apparatus for forming a tubular structure in a subterranean formation  
2 having a preexisting tubular member positioned in a borehole, comprising:  
3 means for installing a tubular liner, an expansion cone, and a shoe in the  
4 borehole;  
5 means for radially expanding at least a portion of the shoe;  
6 means for lowering the expansion cone into the radially expanded portion of the  
7 shoe;  
8 means for radially expanding the expansion cone;  
9 means for radially expanding at least a portion of the tubular liner; and  
10 means for overlapping a portion of the radially expanded tubular liner with a  
11 portion of the preexisting tubular member to provide a load bearing  
12 interface and a fluidic seal;

13 wherein the inside diameter of the radially expanded shoe is greater than or  
14 substantially equal to the inside diameter of the radially expanded  
15 tubular liner; and  
16 wherein the inside diameter of the radially expanded tubular liner is  
17 substantially equal to the inside diameter of a nonoverlapping portion of  
18 the preexisting tubular member.

1 82. A tubular structure positioned in a borehole within a subterranean formation,  
2 comprising:  
3 a first tubular member; and  
4 a second tubular member coupled to and overlapping with the first tubular  
5 member;  
6 wherein the second tubular member is coupled to the first tubular member by  
7 the process of:  
8 installing the second tubular member, an expansion cone, and a shoe in  
9 the borehole;  
10 radially expanding at least a portion of the shoe by injecting a fluidic  
11 material into the shoe;  
12 lowering the expansion cone into the radially expanded portion of the  
13 shoe;  
14 radially expanding the expansion cone;  
15 radially expanding at least a portion of the second tubular member by  
16 injecting a fluidic material into the borehole below the radially  
17 expanded expansion cone; and  
18 overlapping a portion of the radially expanded second tubular member  
19 with a portion of the first tubular member;  
20 wherein the inside diameter of the radially expanded shoe is greater than  
21 or substantially equal to the inside diameter of the radially  
22 expanded second tubular member; and  
23 wherein the inside diameter of the radially expanded second tubular  
24 member is substantially equal to the inside diameter of a  
25 nonoverlapping portion of the first tubular member.

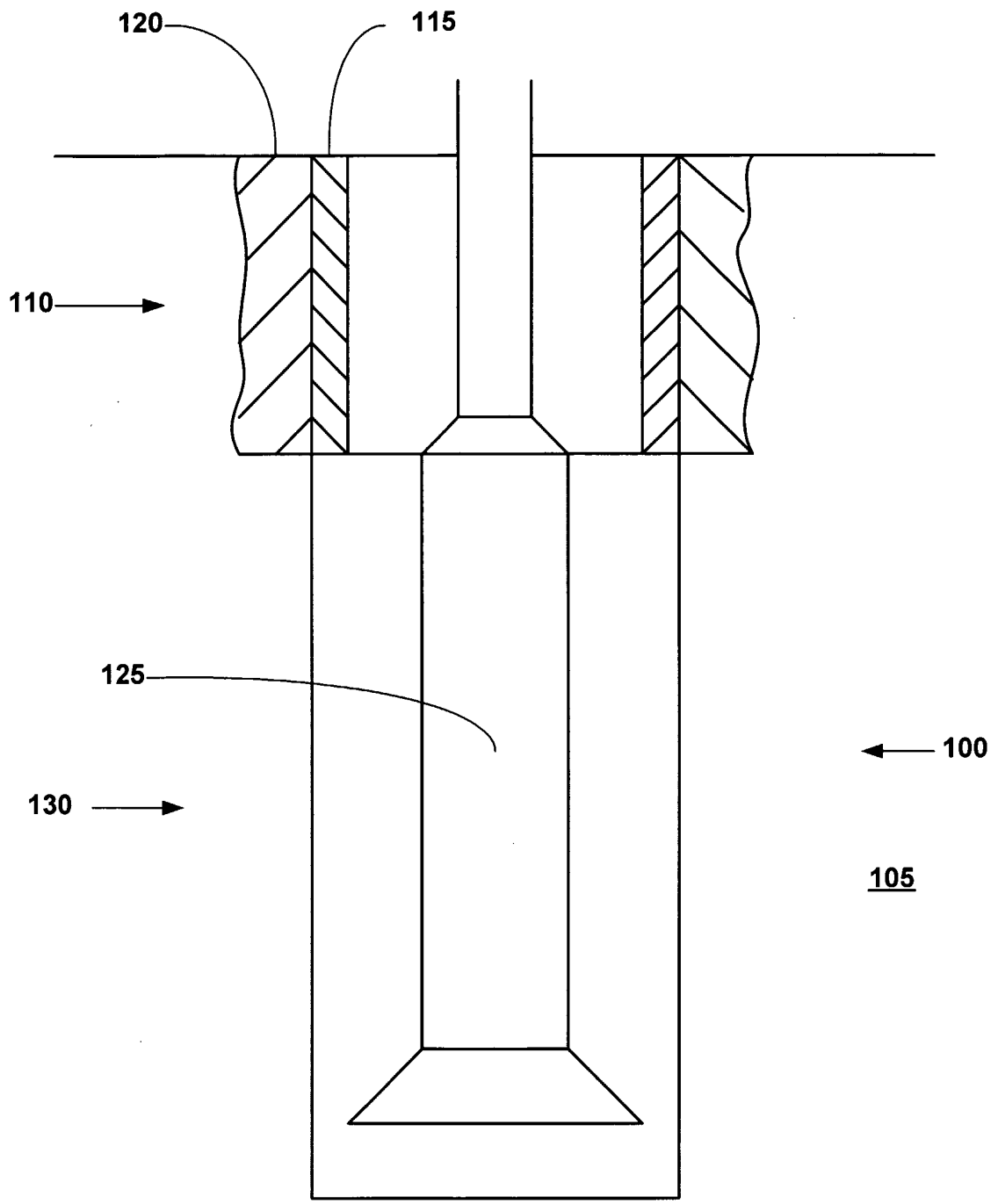
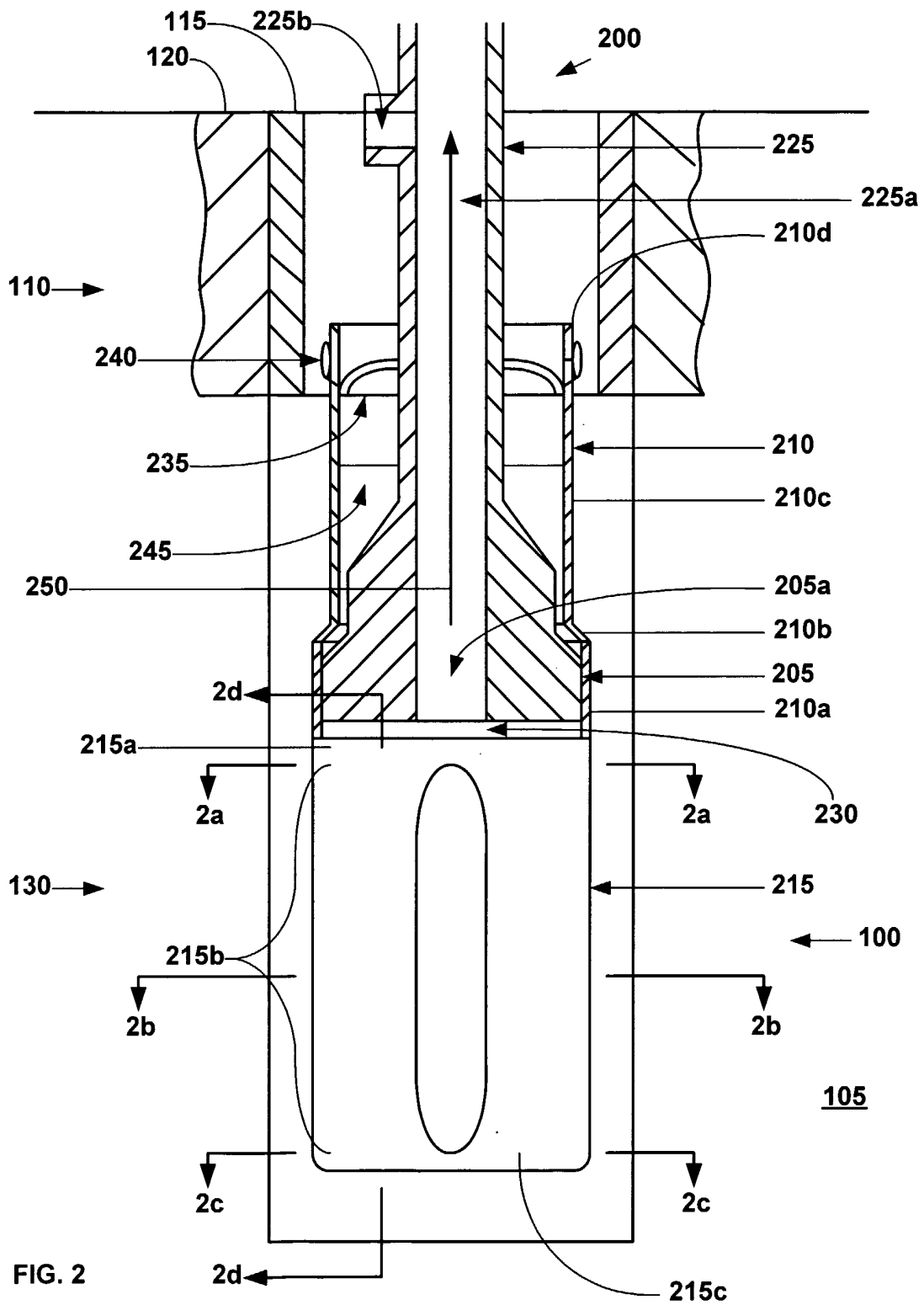

FIG. 1





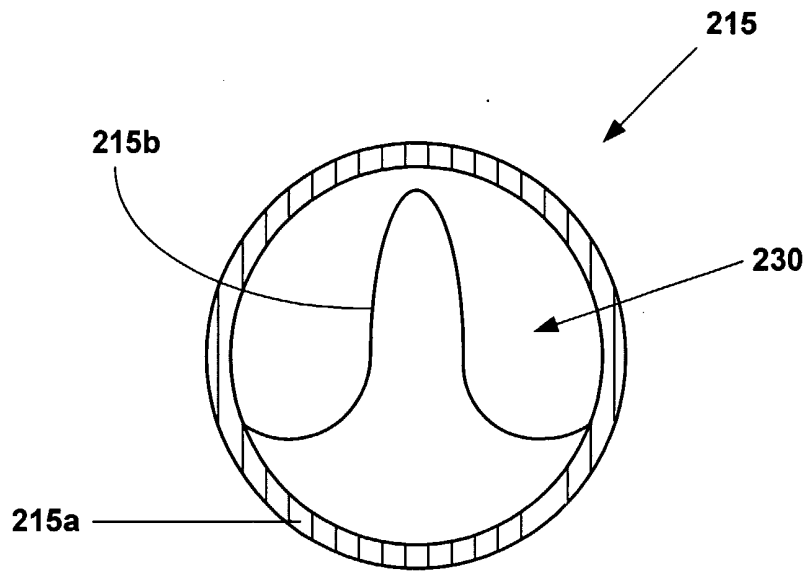

FIG. 2a

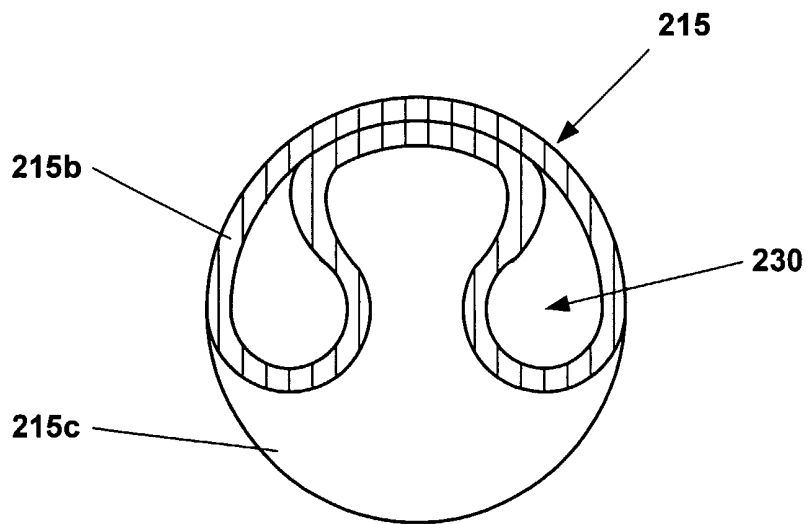

FIG. 2b

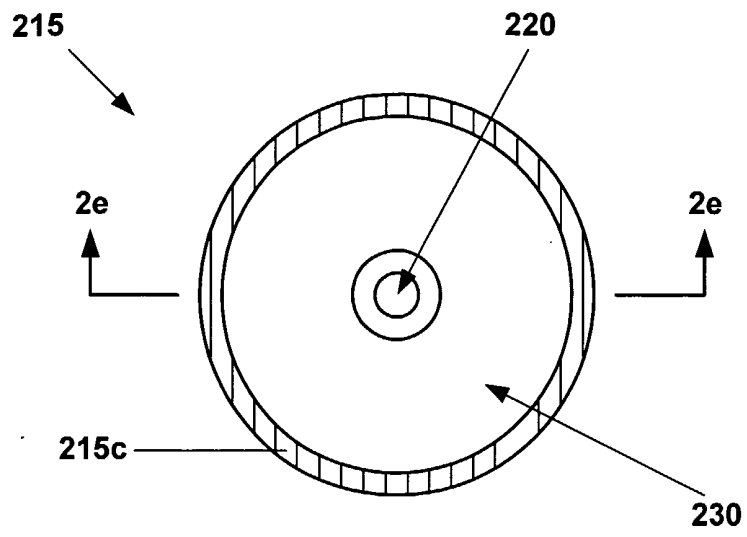

FIG. 2c

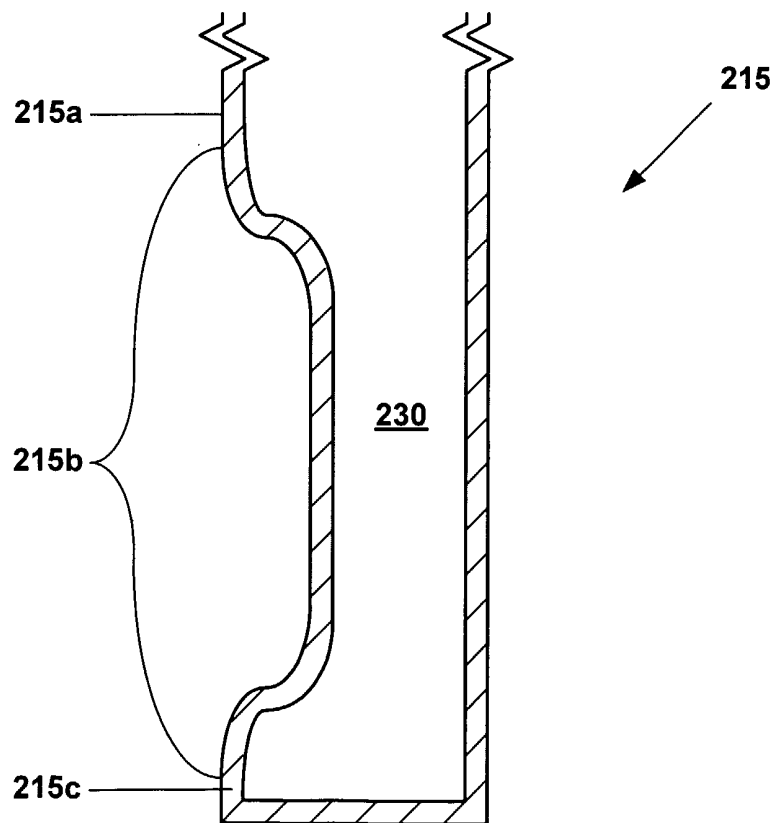

FIG. 2d

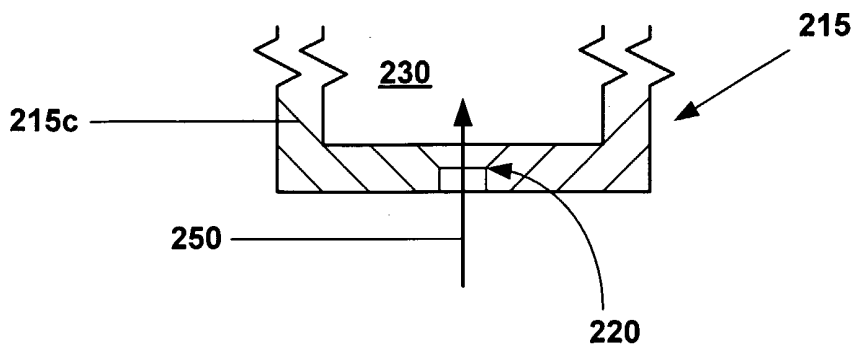

FIG. 2e

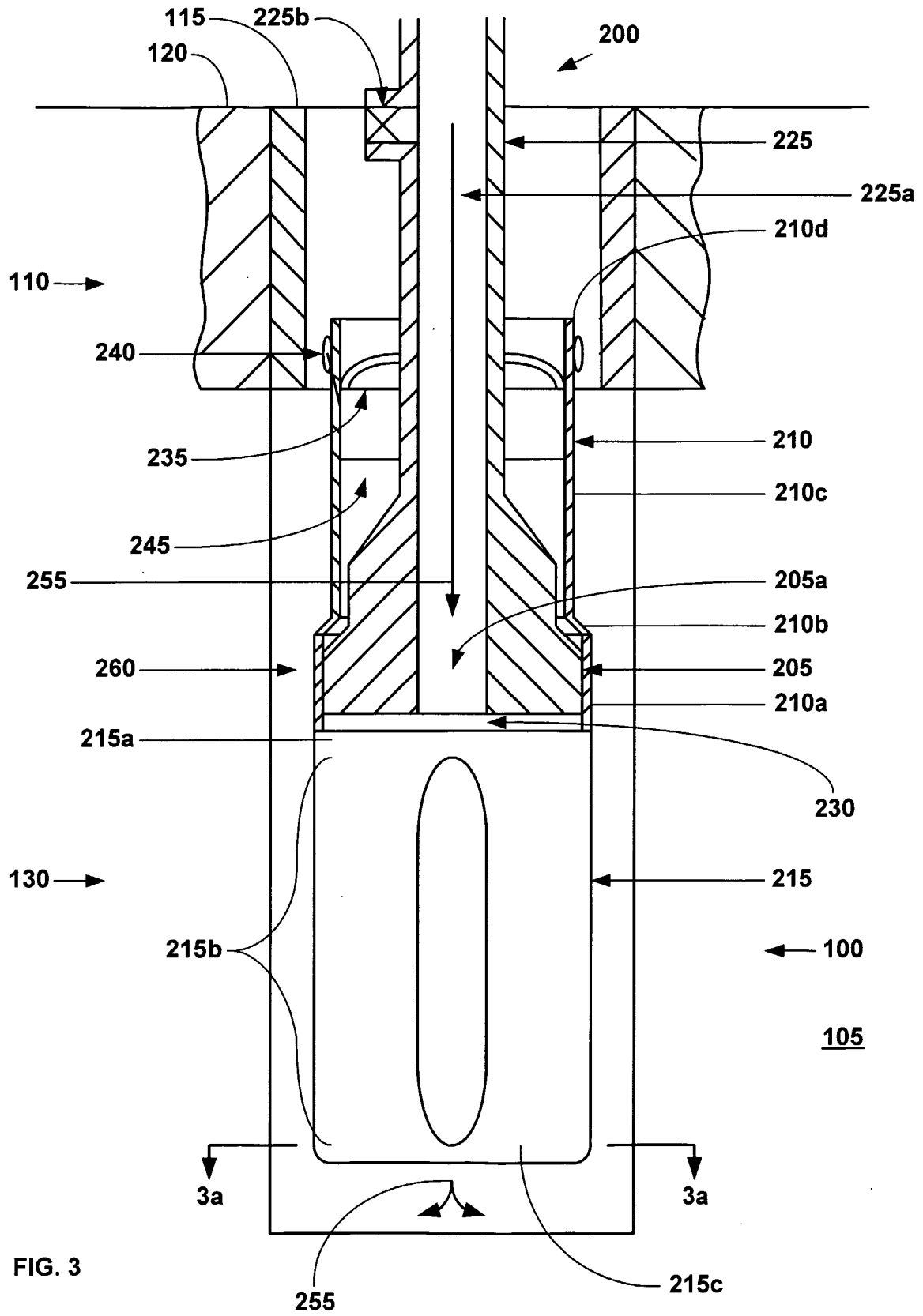

FIG. 3

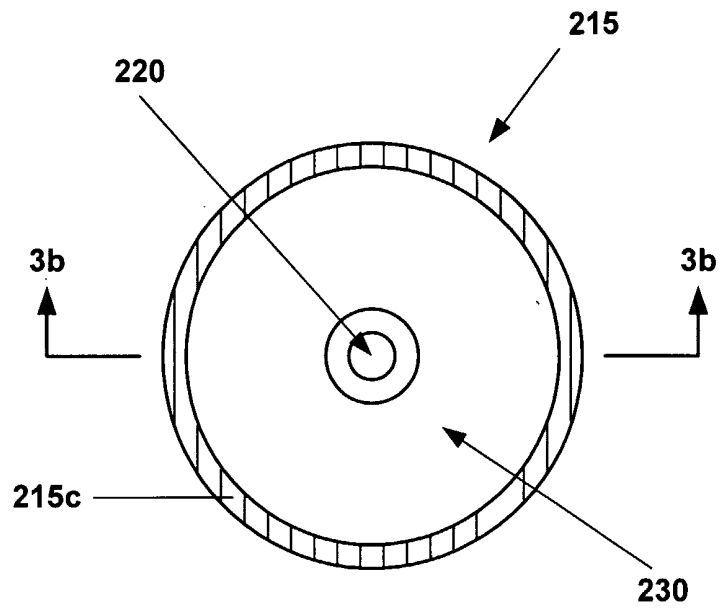

FIG. 3a

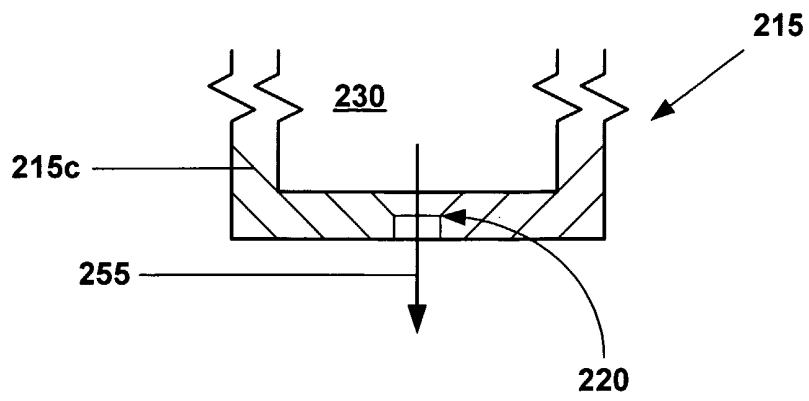

FIG. 3b

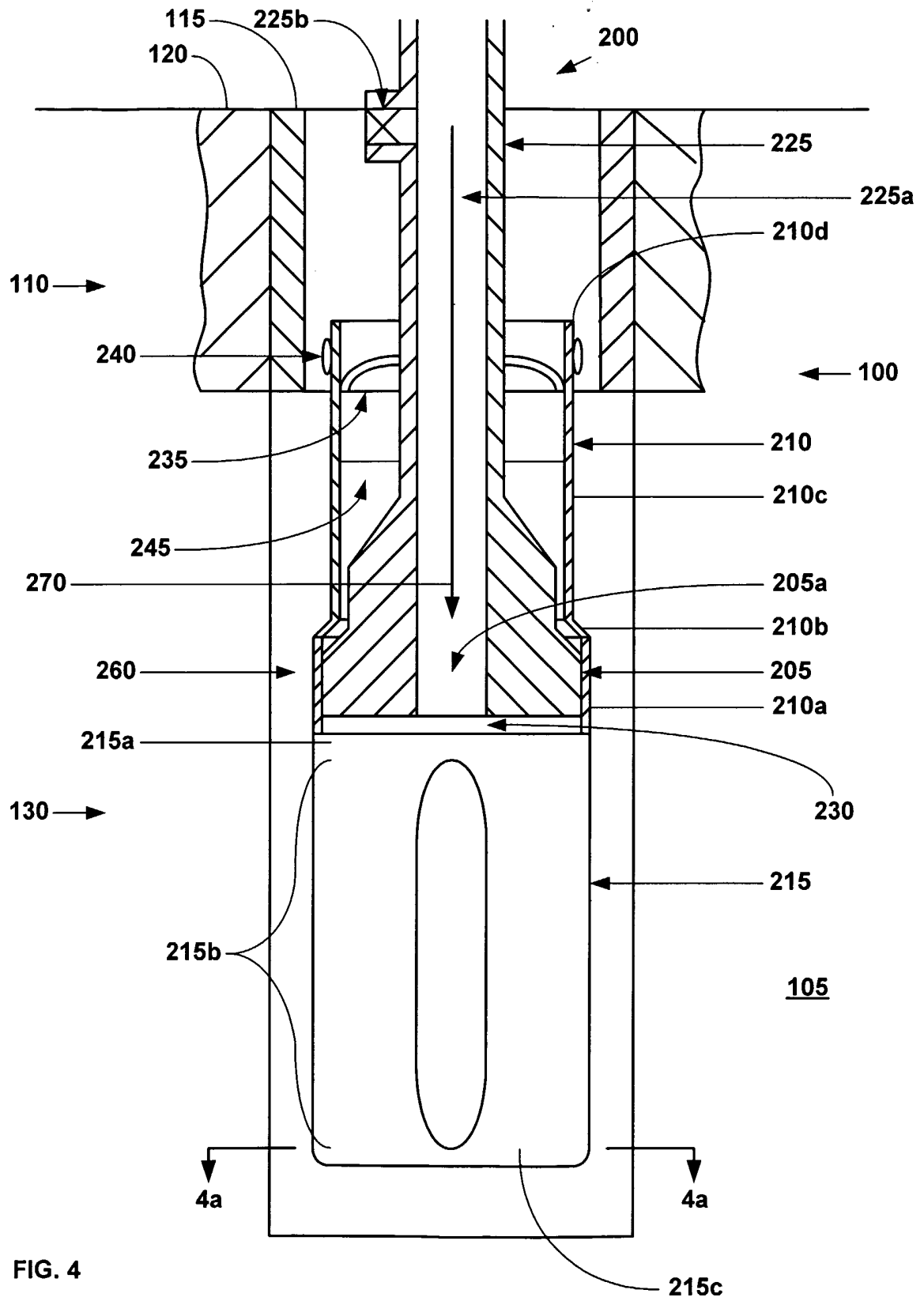

FIG. 4

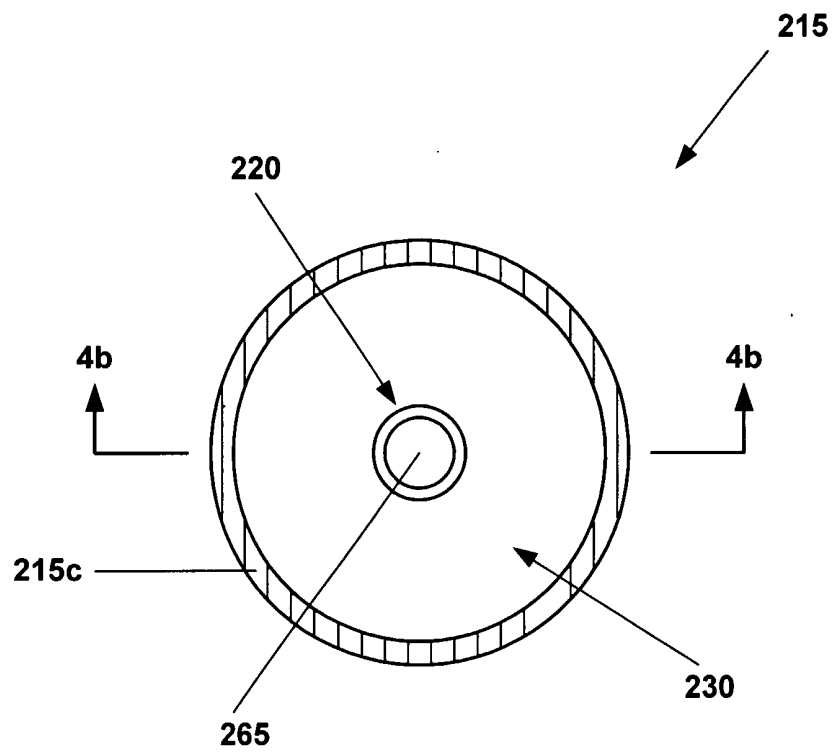

FIG. 4a

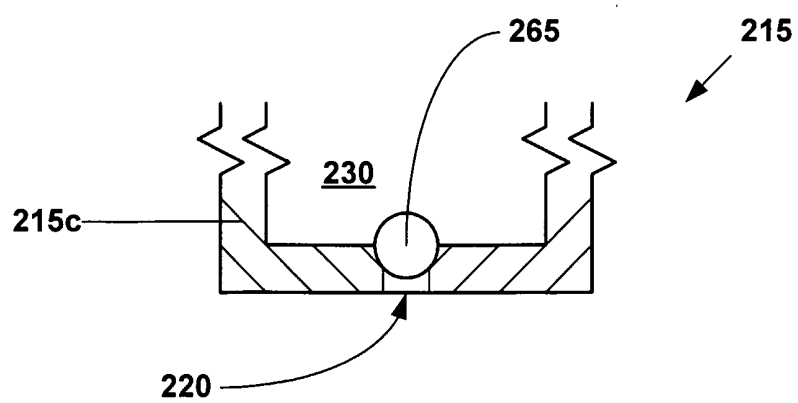

FIG. 4b



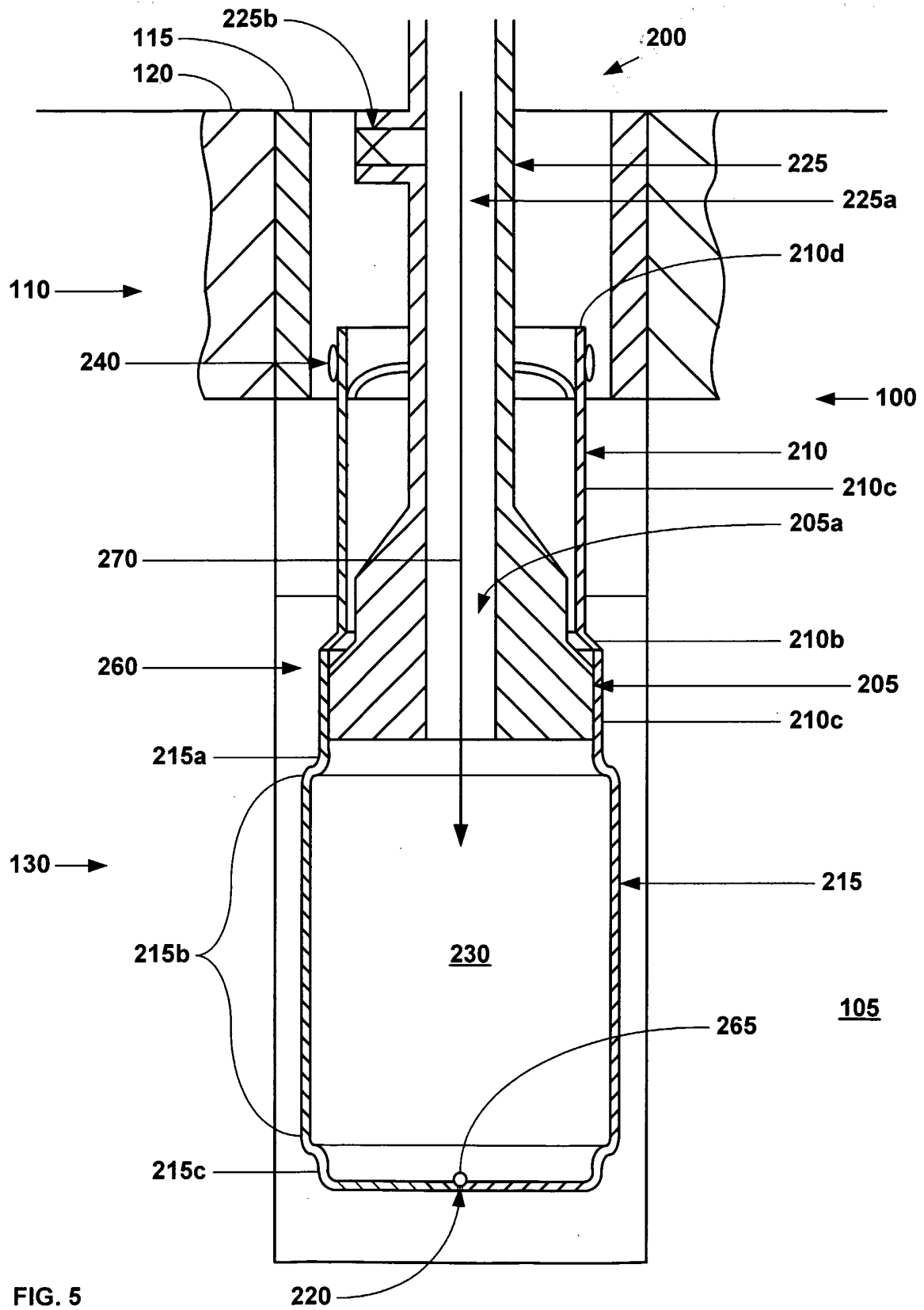

FIG. 5

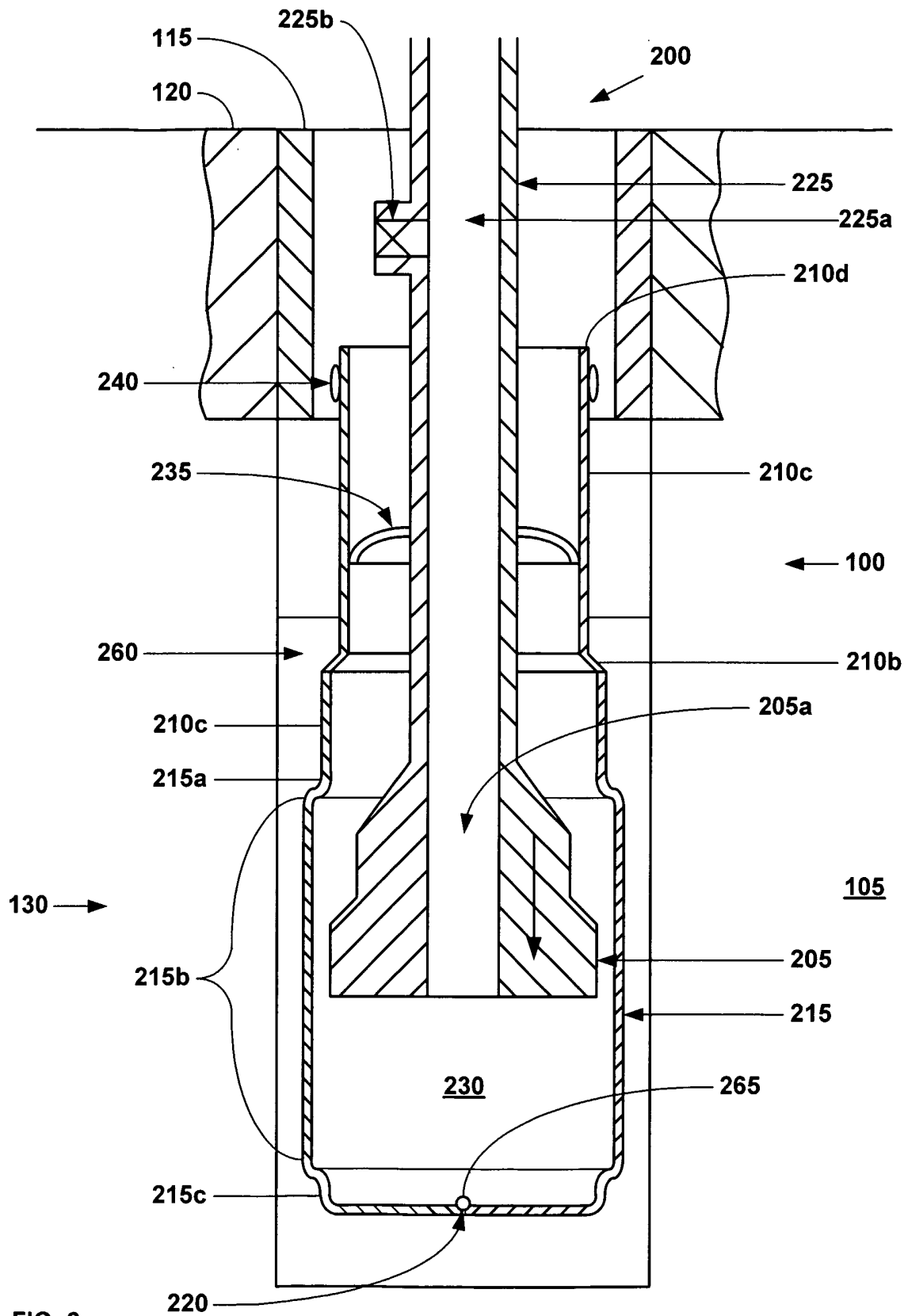
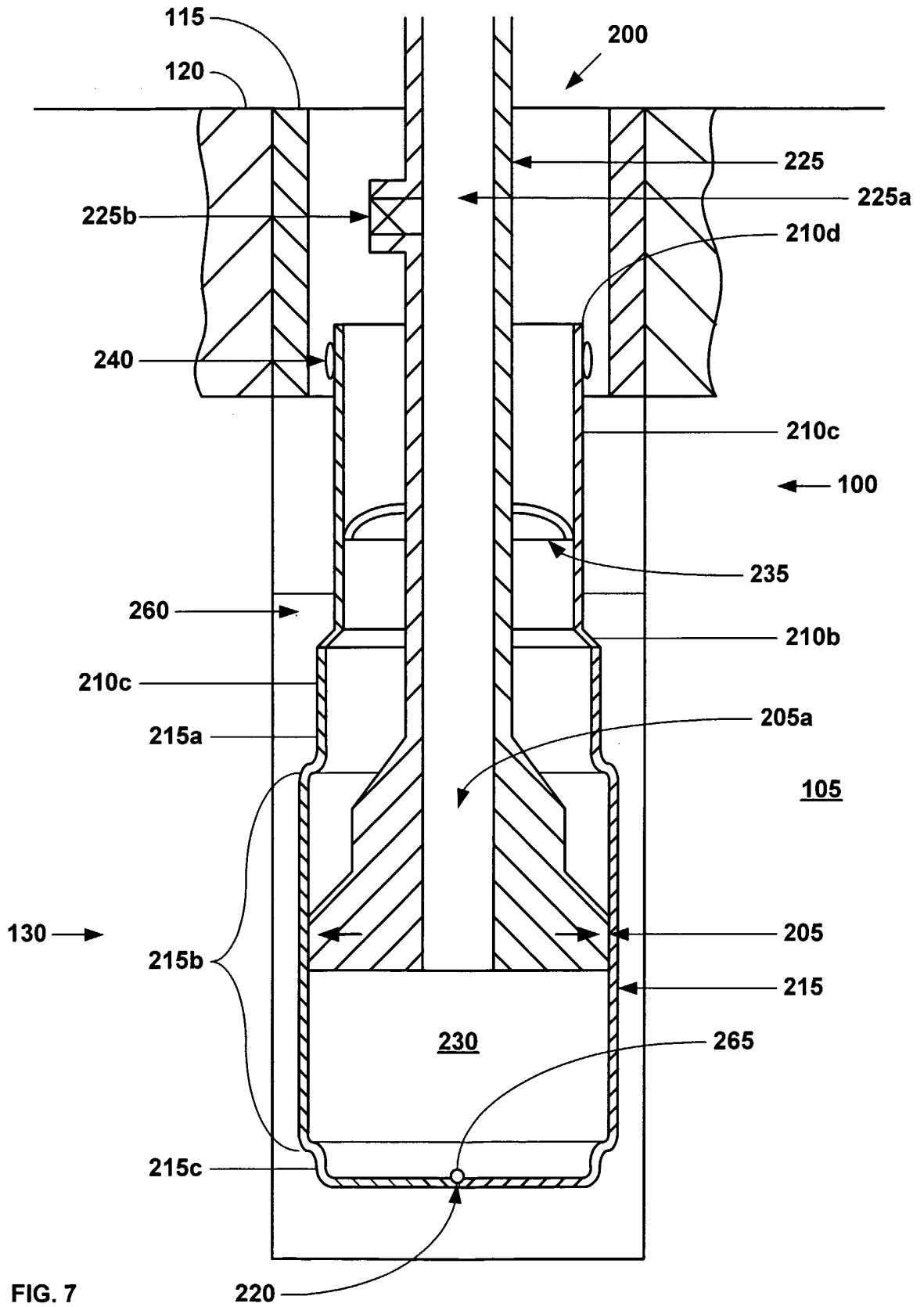
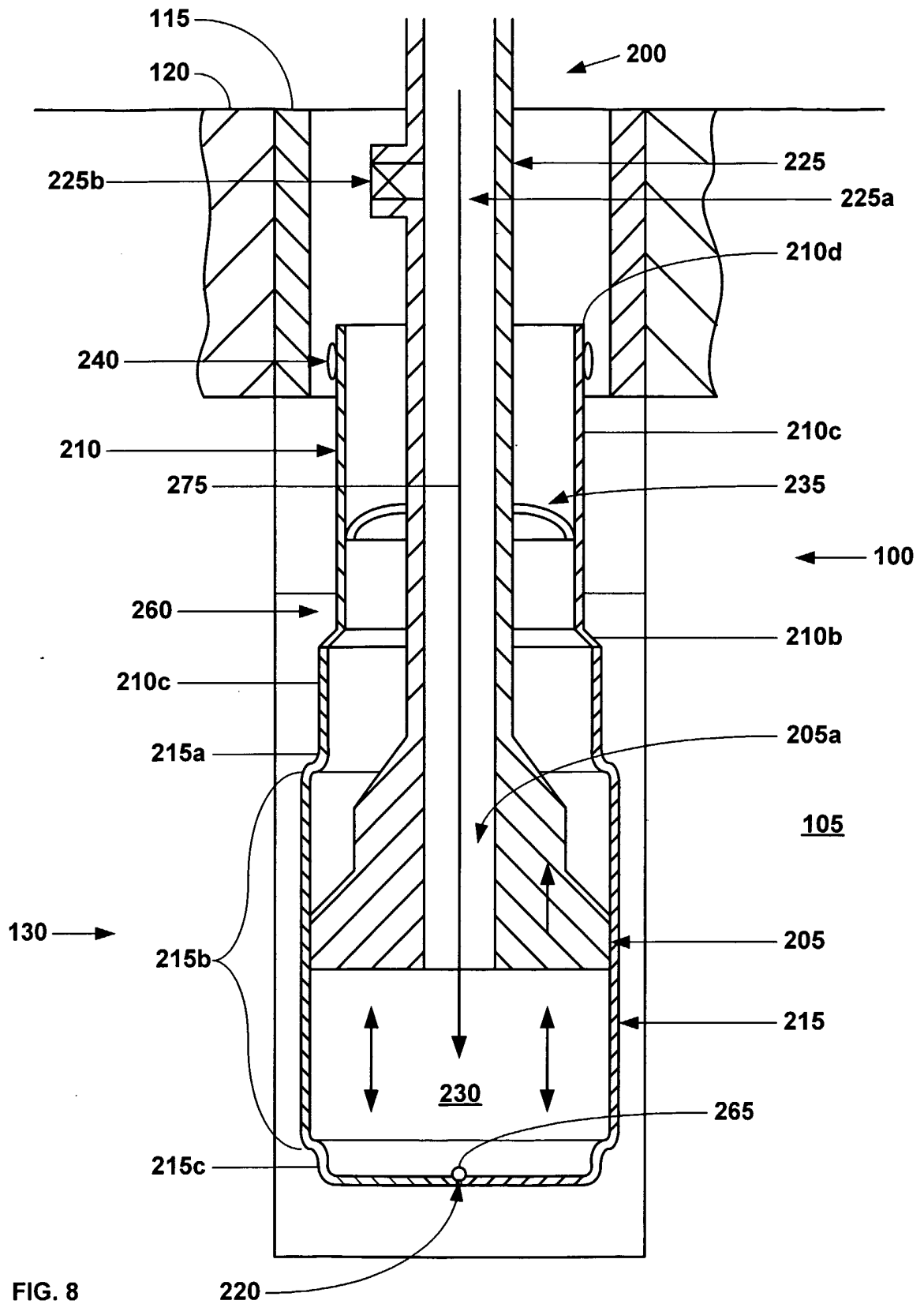

FIG. 6





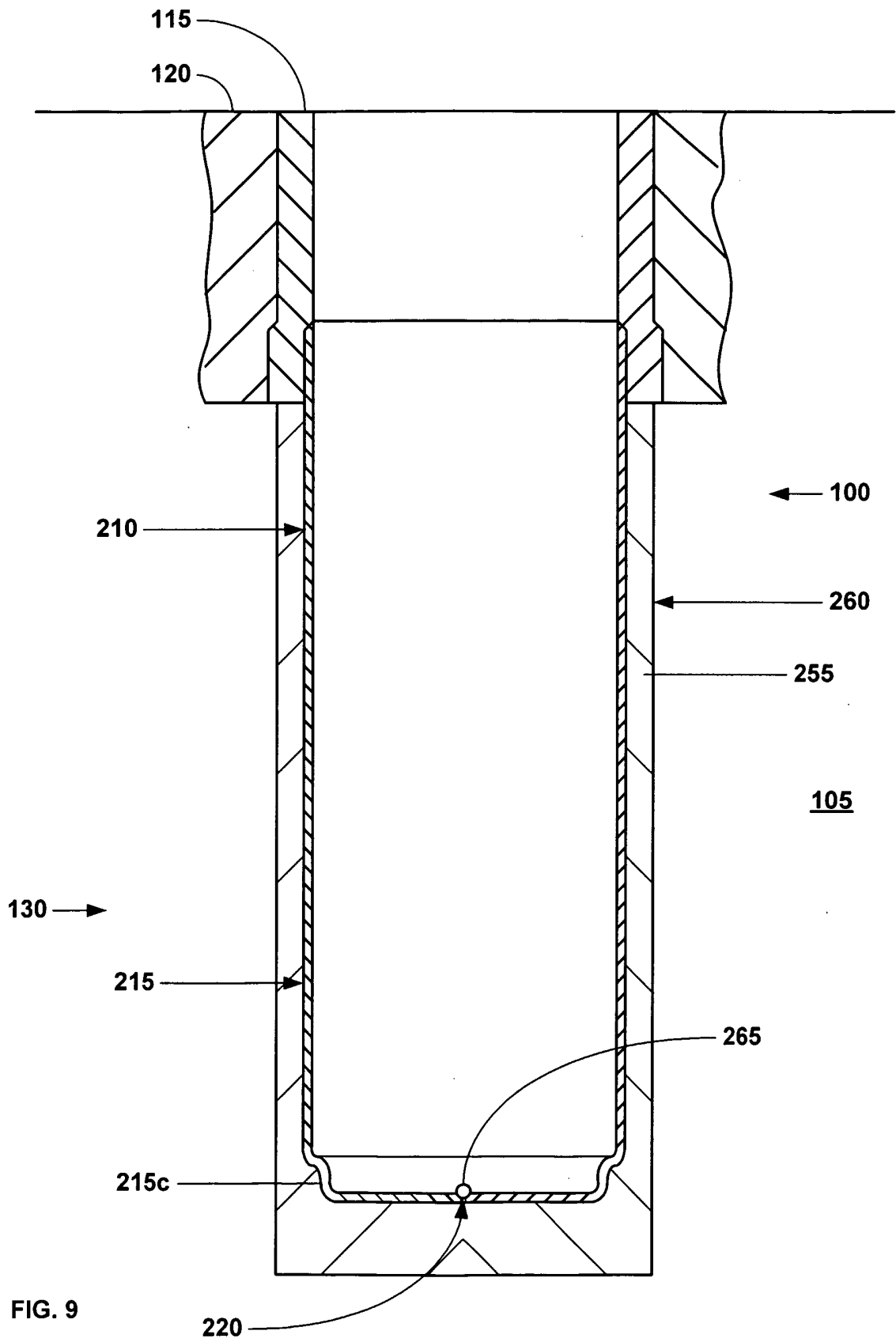

FIG. 9

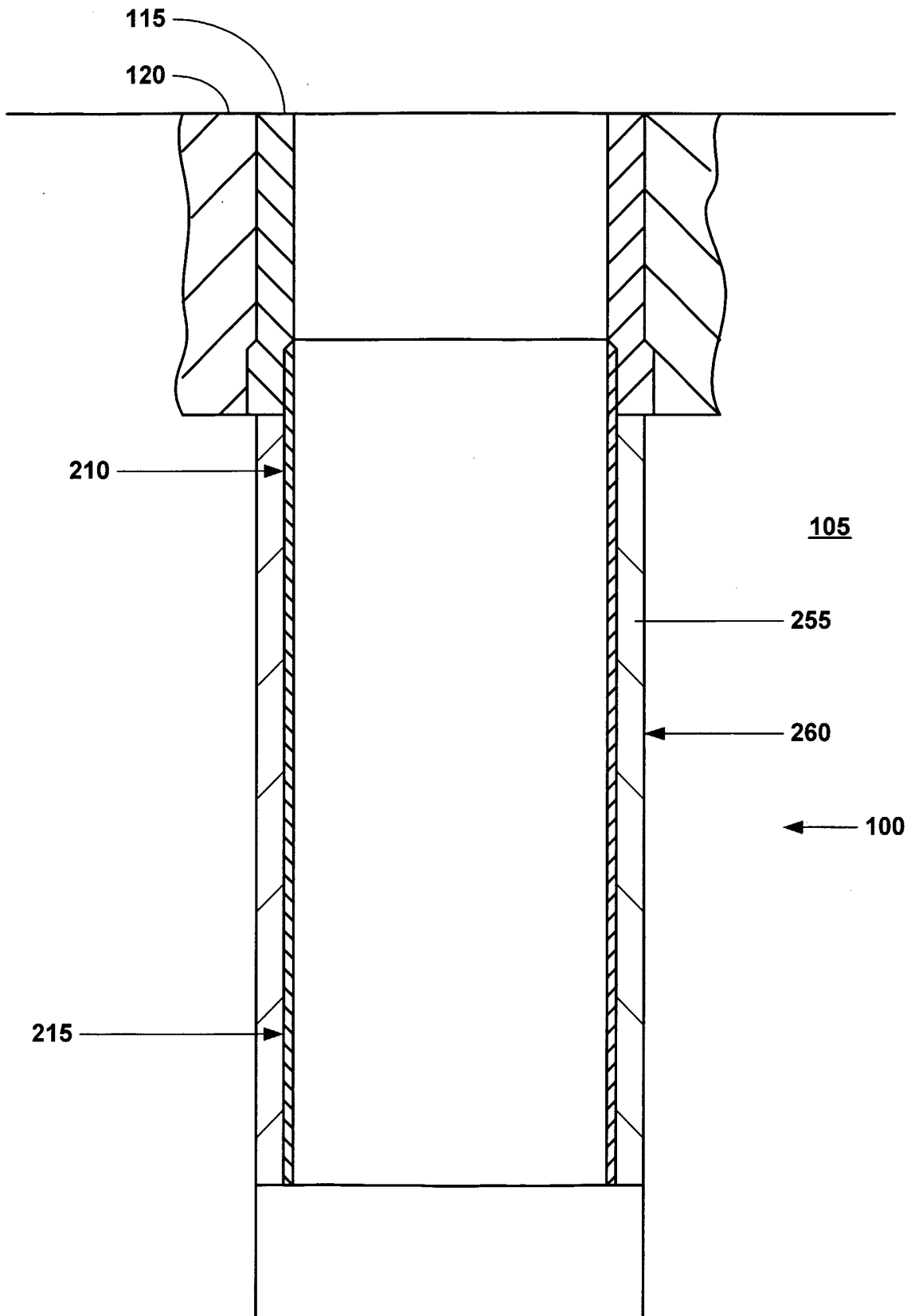

FIG. 10

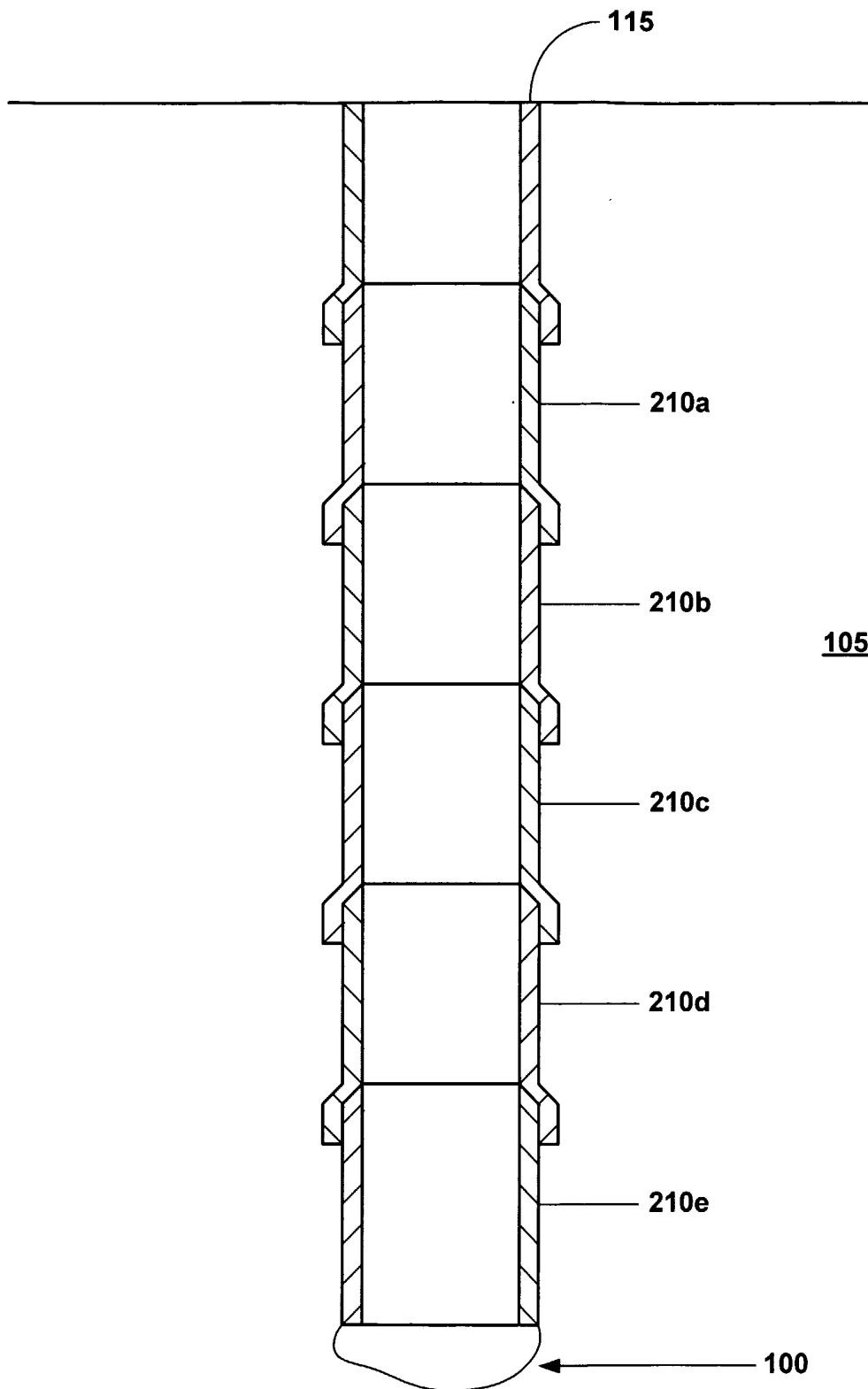

FIG. 11

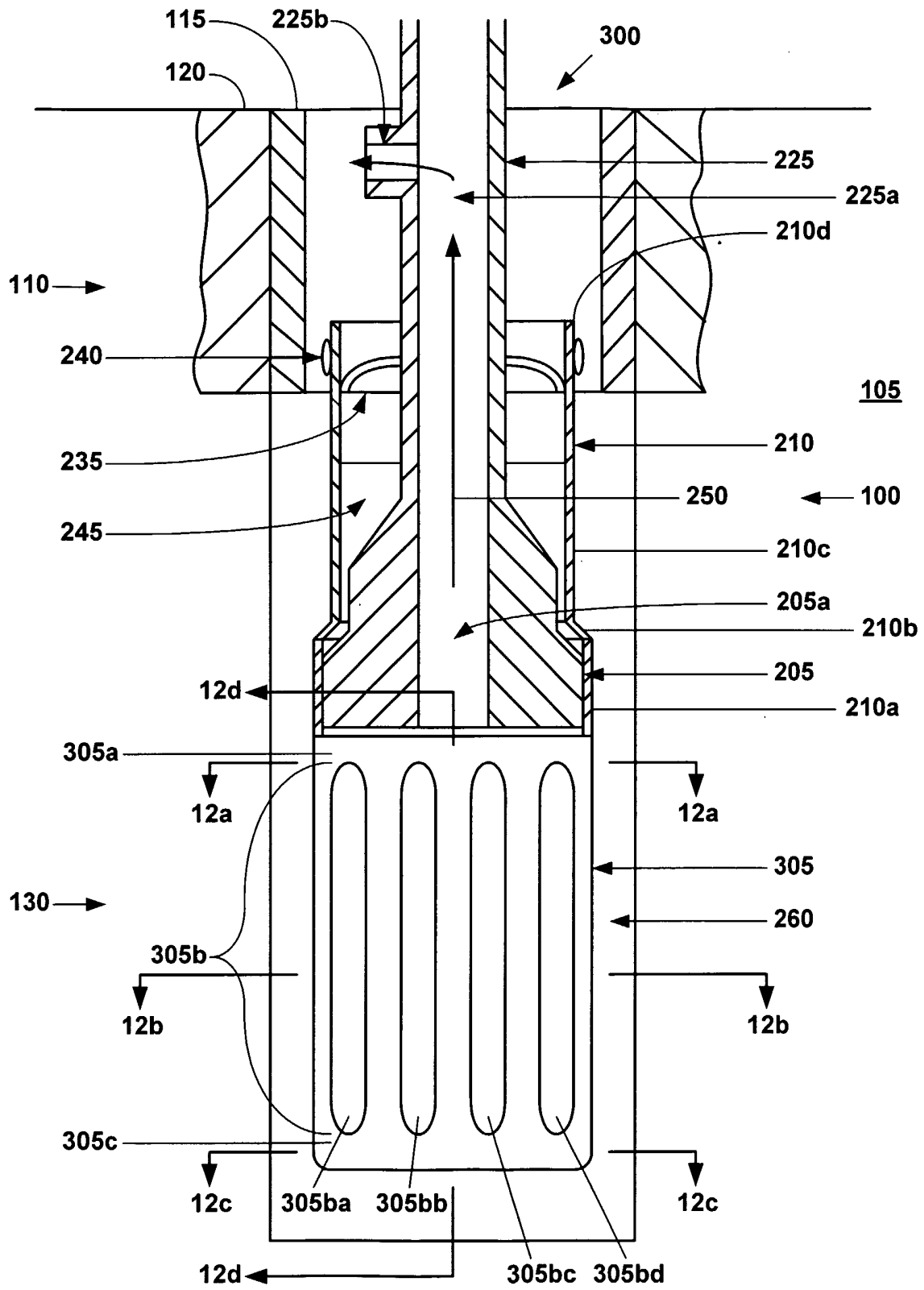

FIG. 12



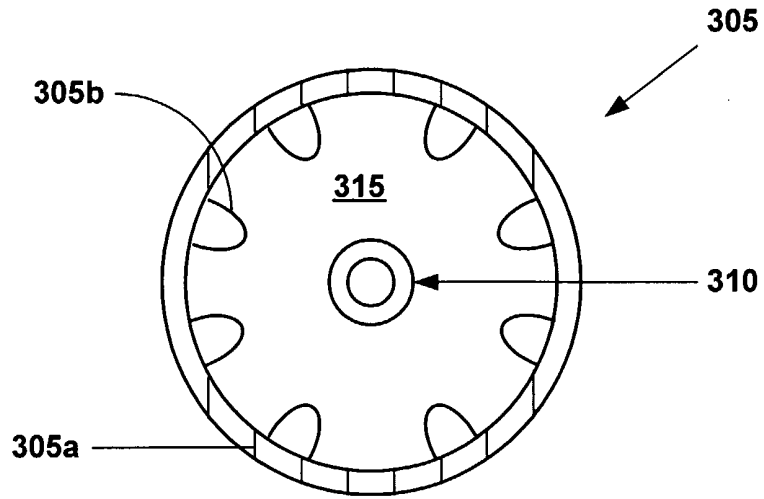

FIG. 12a

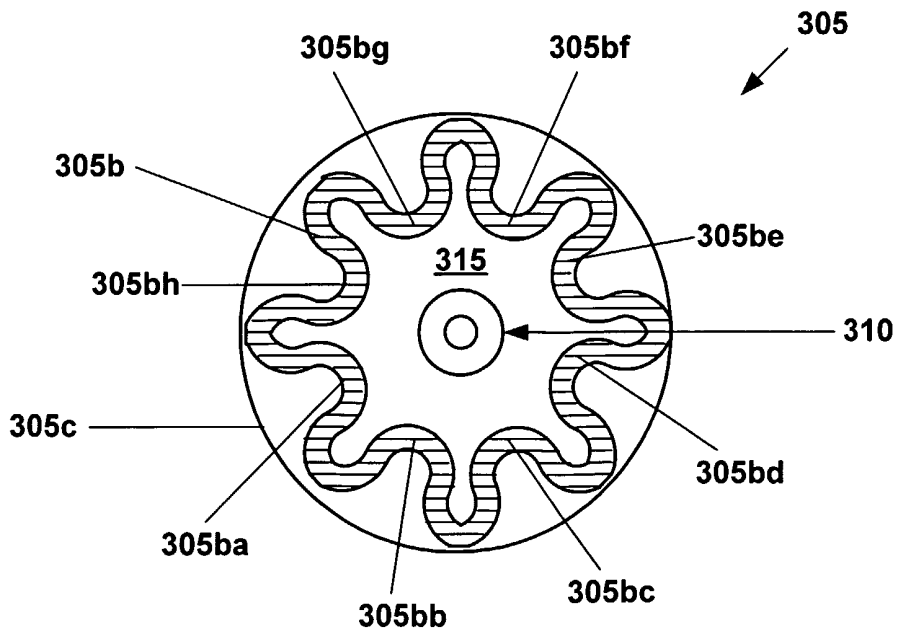

FIG. 12b

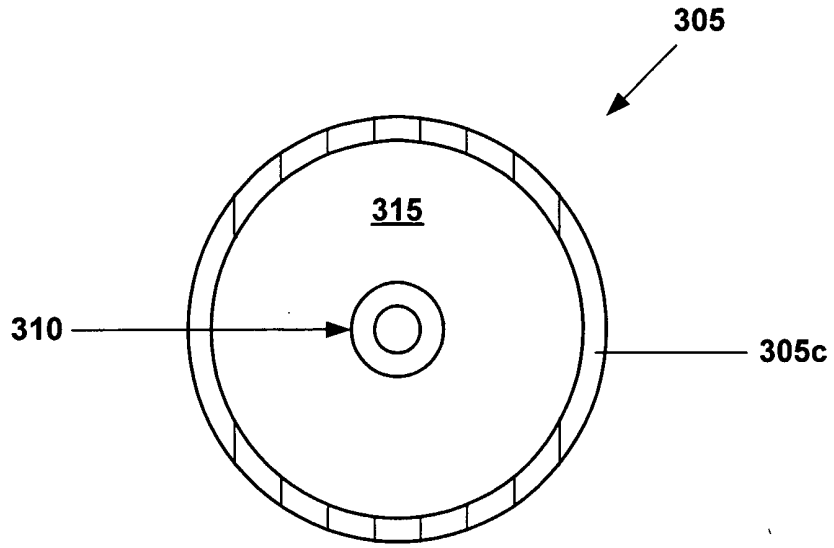

FIG. 12c

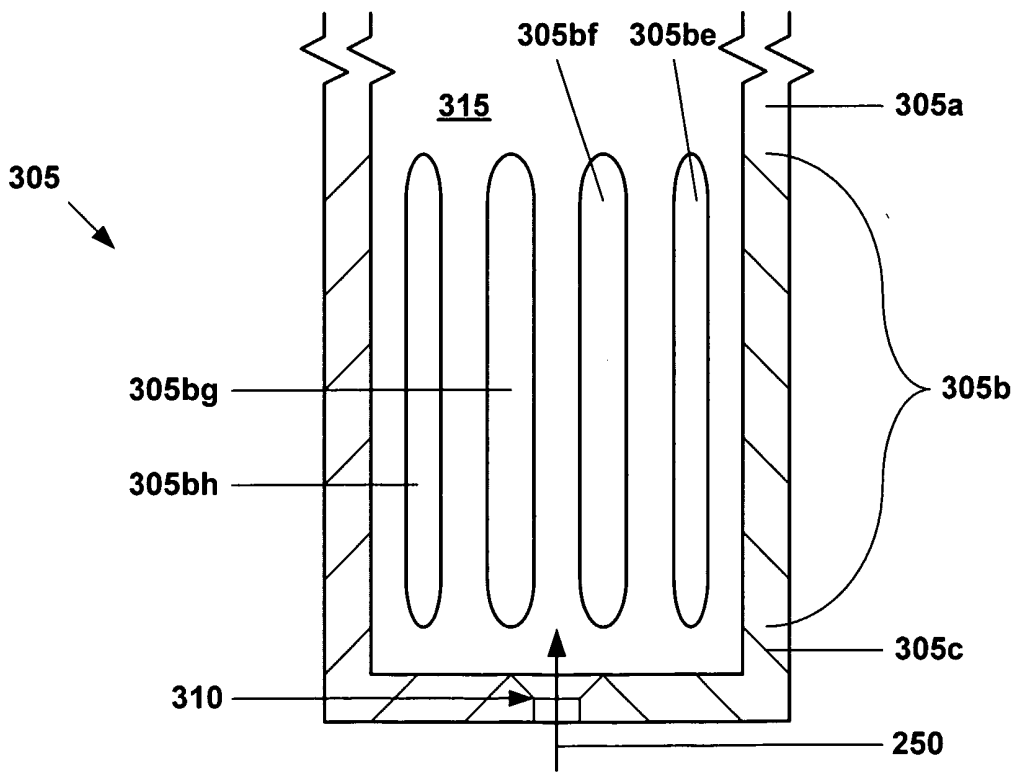

FIG. 12d

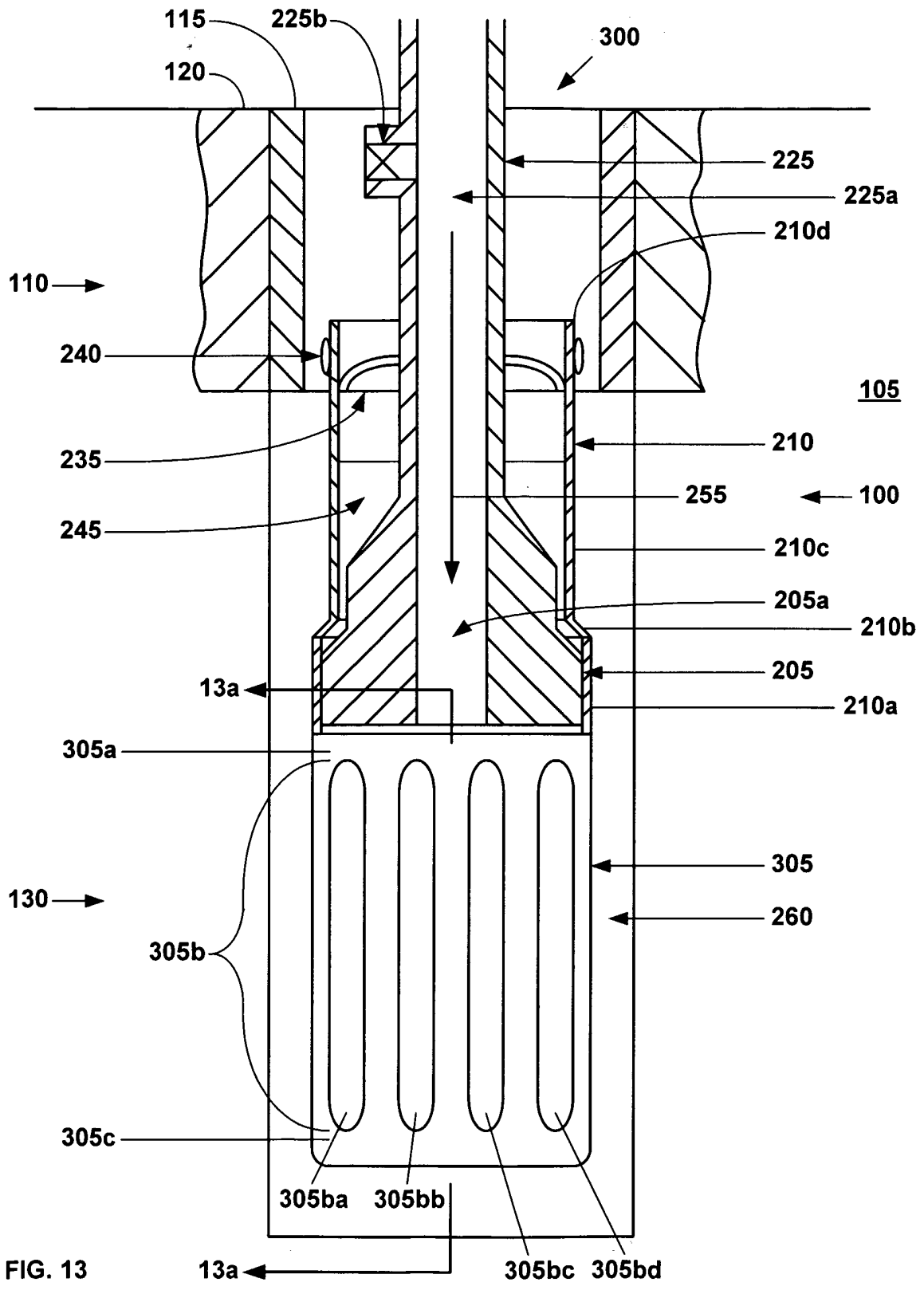

FIG. 13

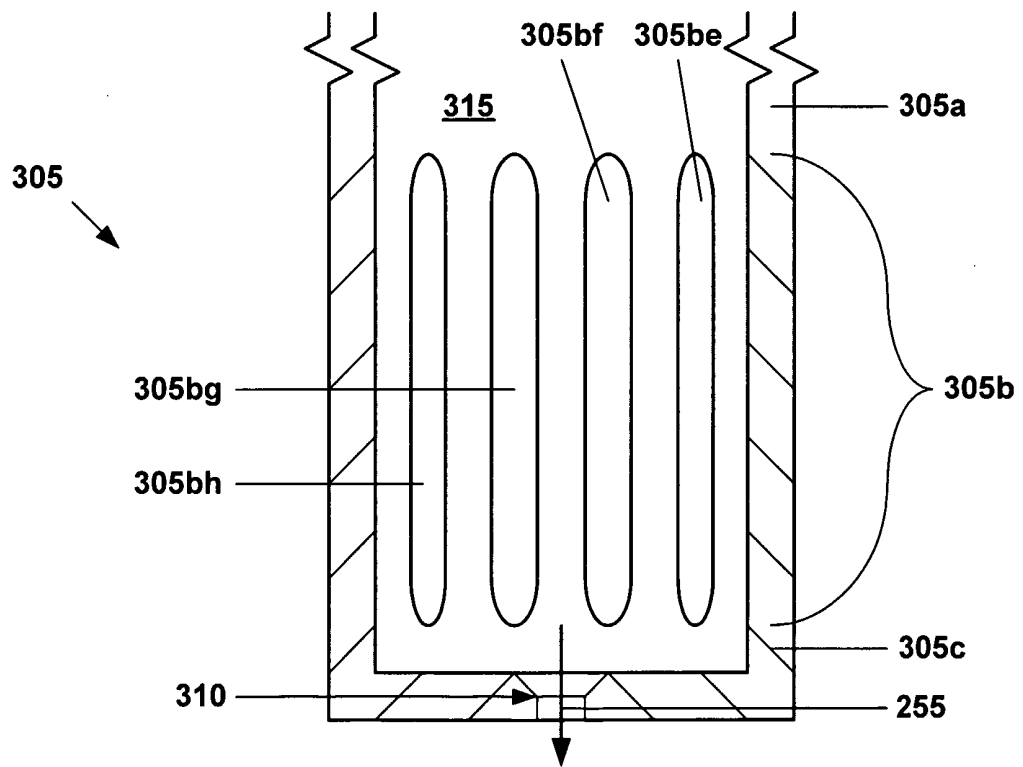

FIG. 13a

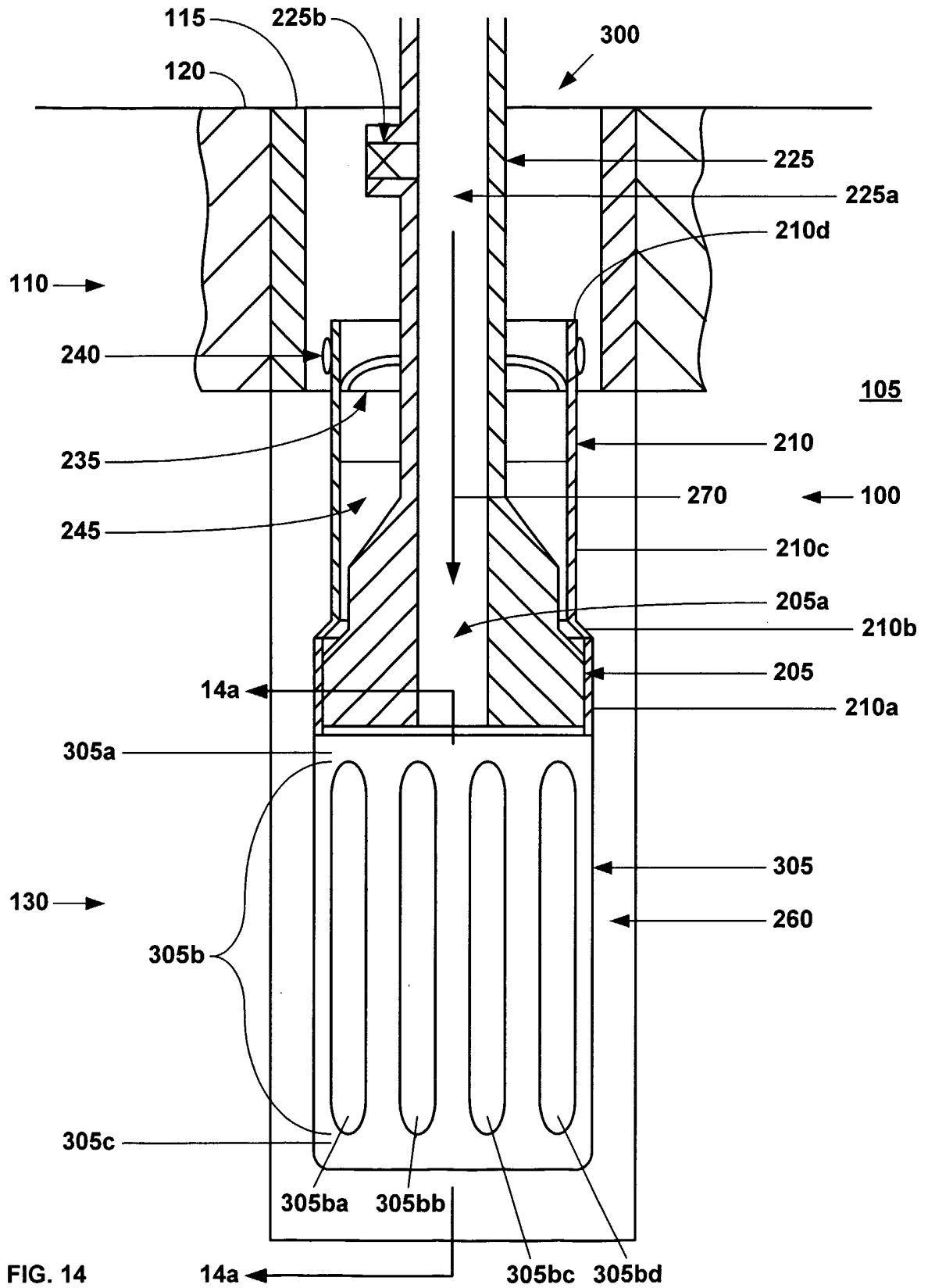

FIG. 14

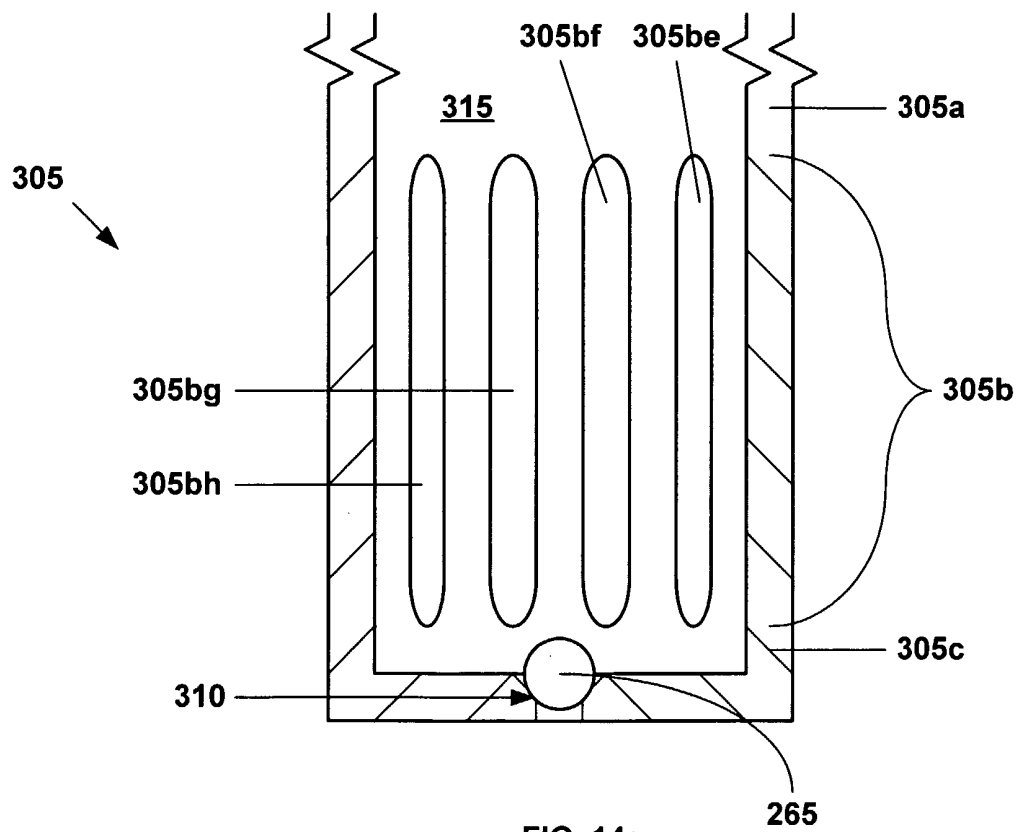

FIG. 14a

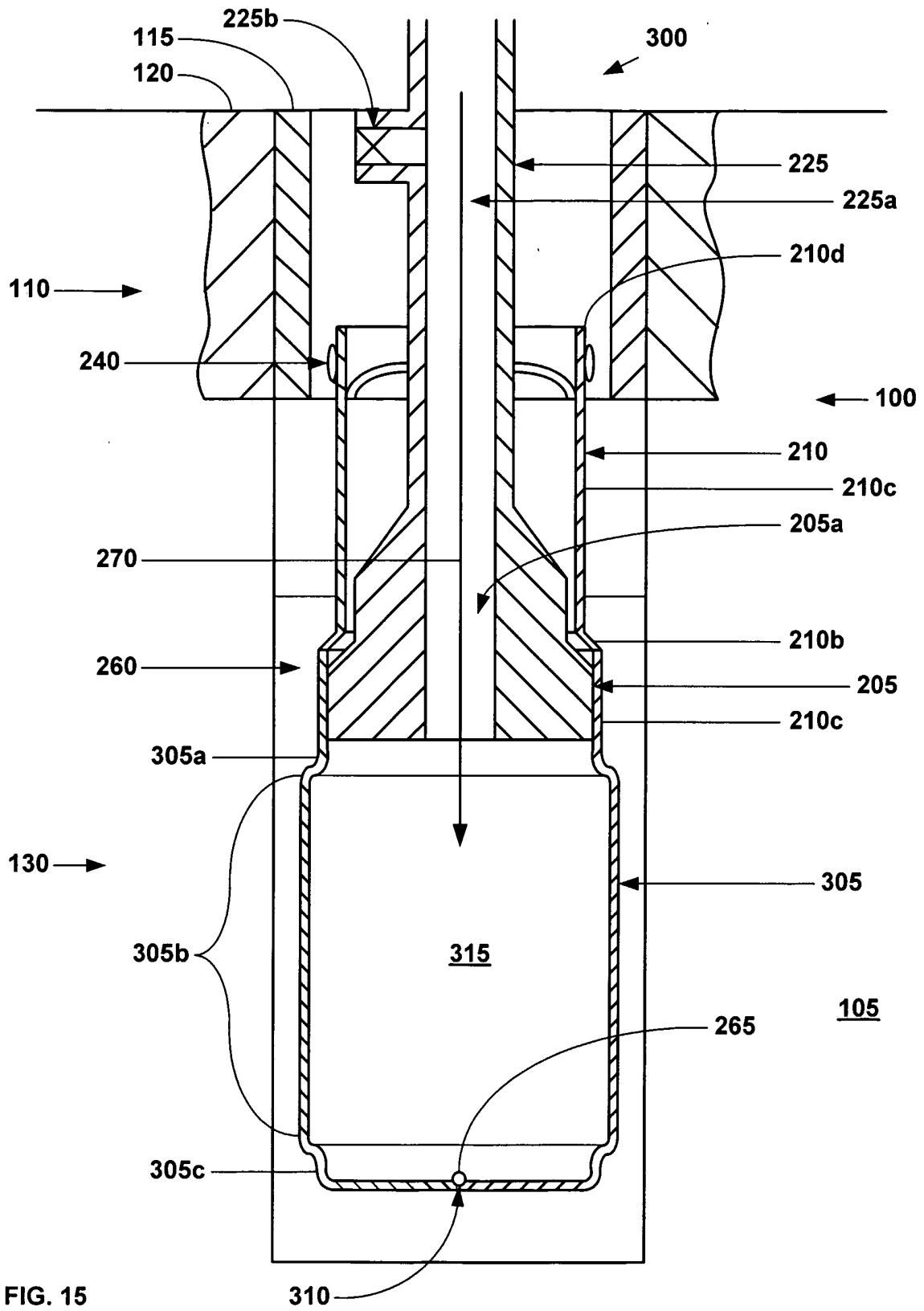

FIG. 15

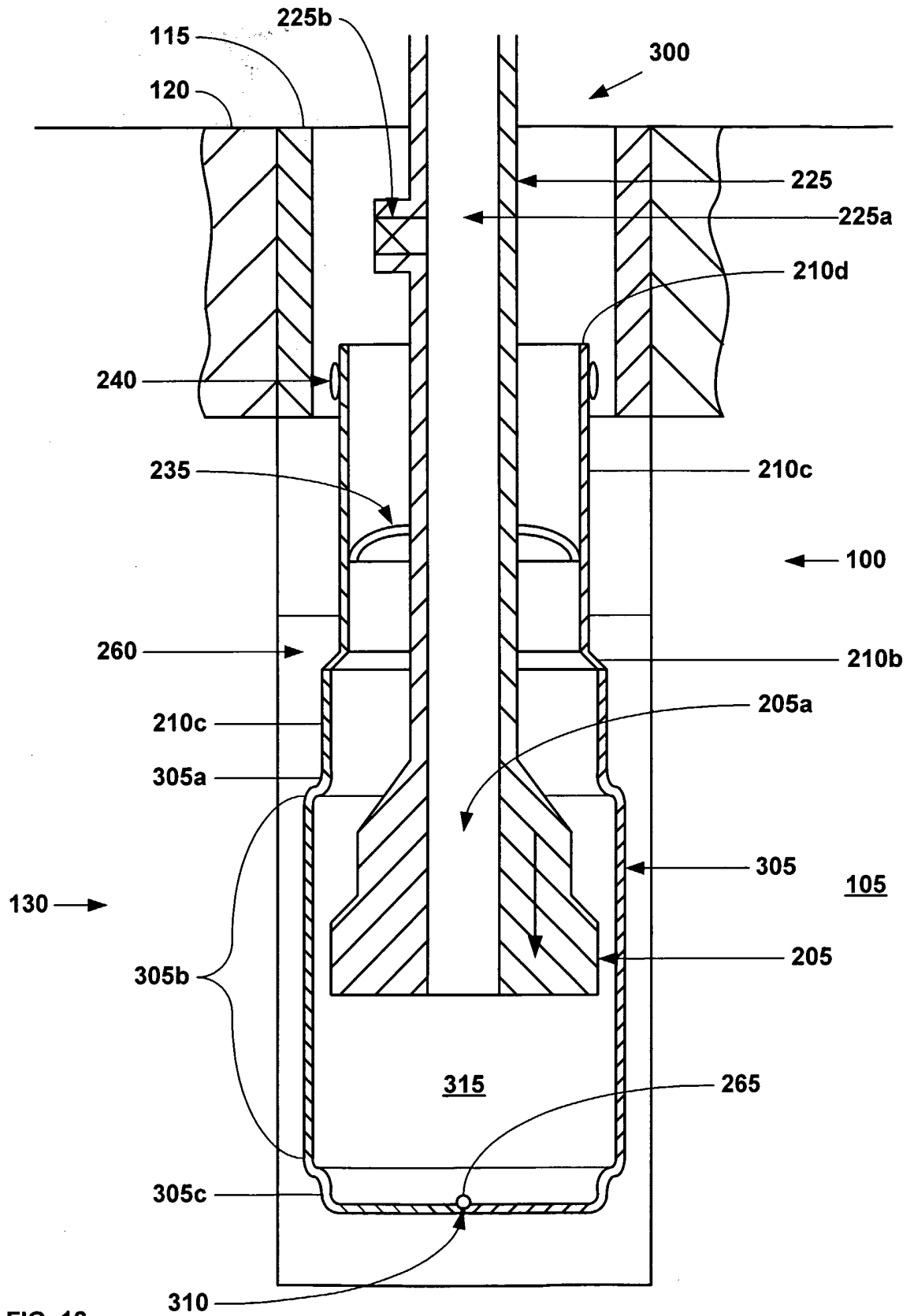
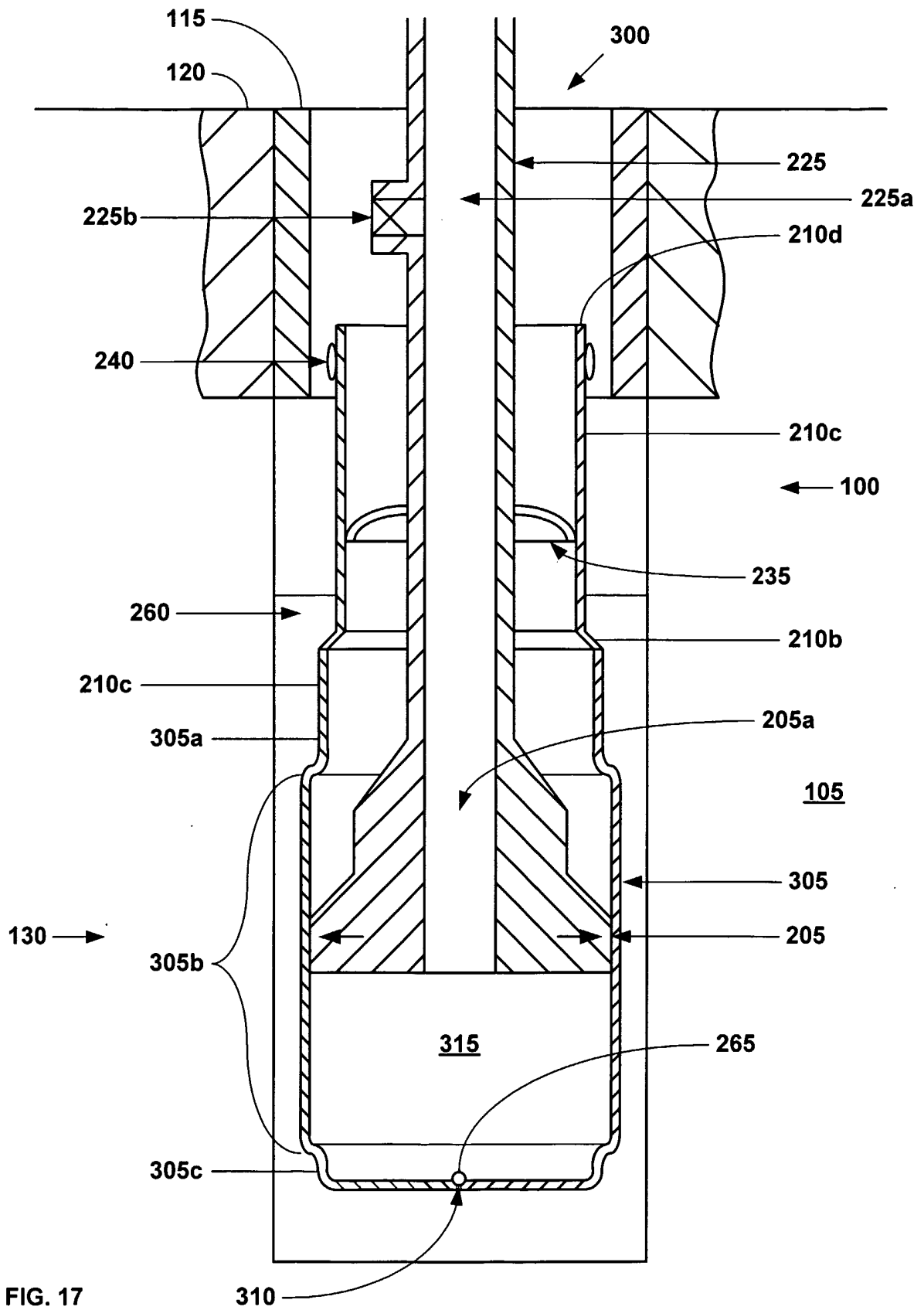
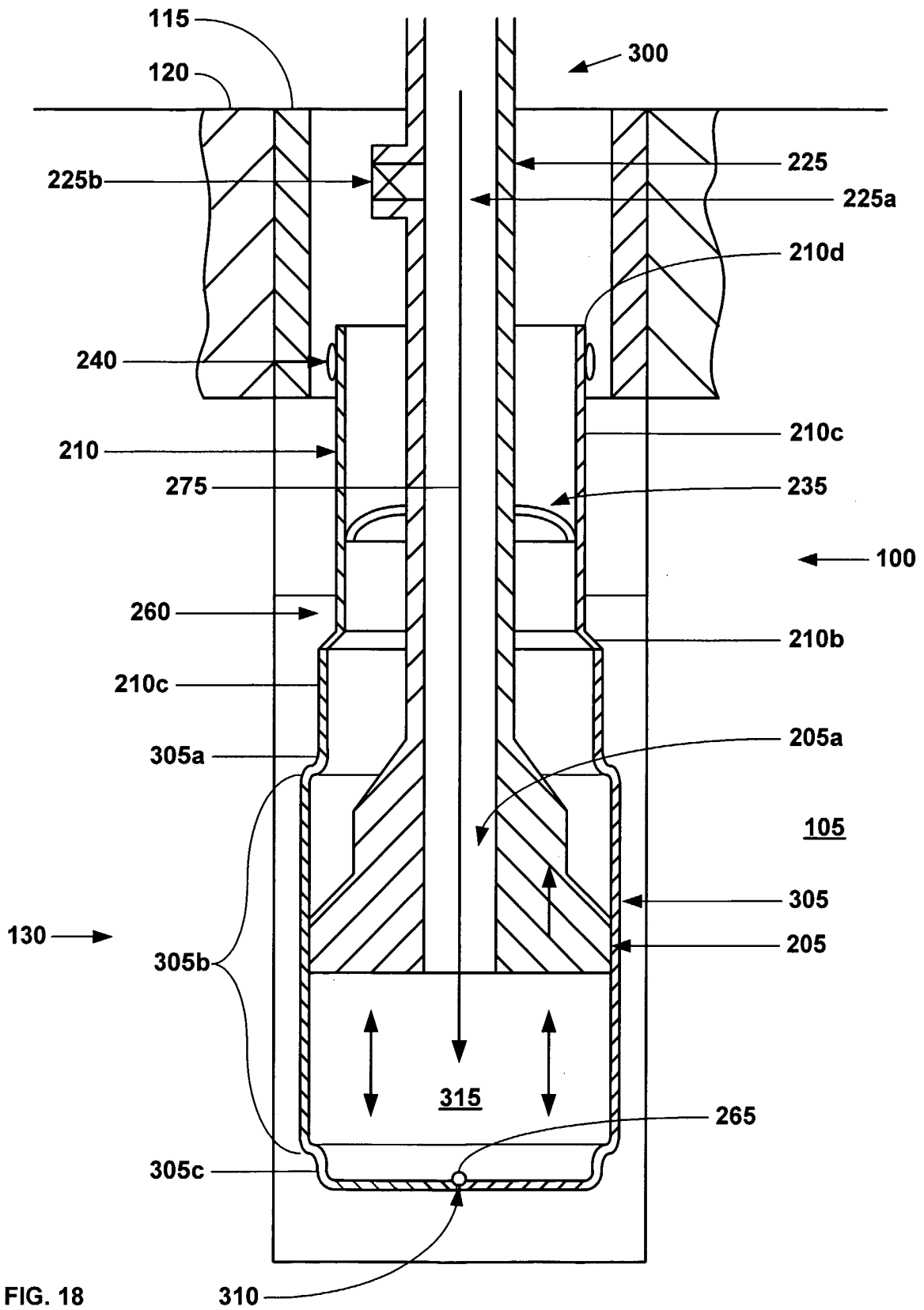

FIG. 16







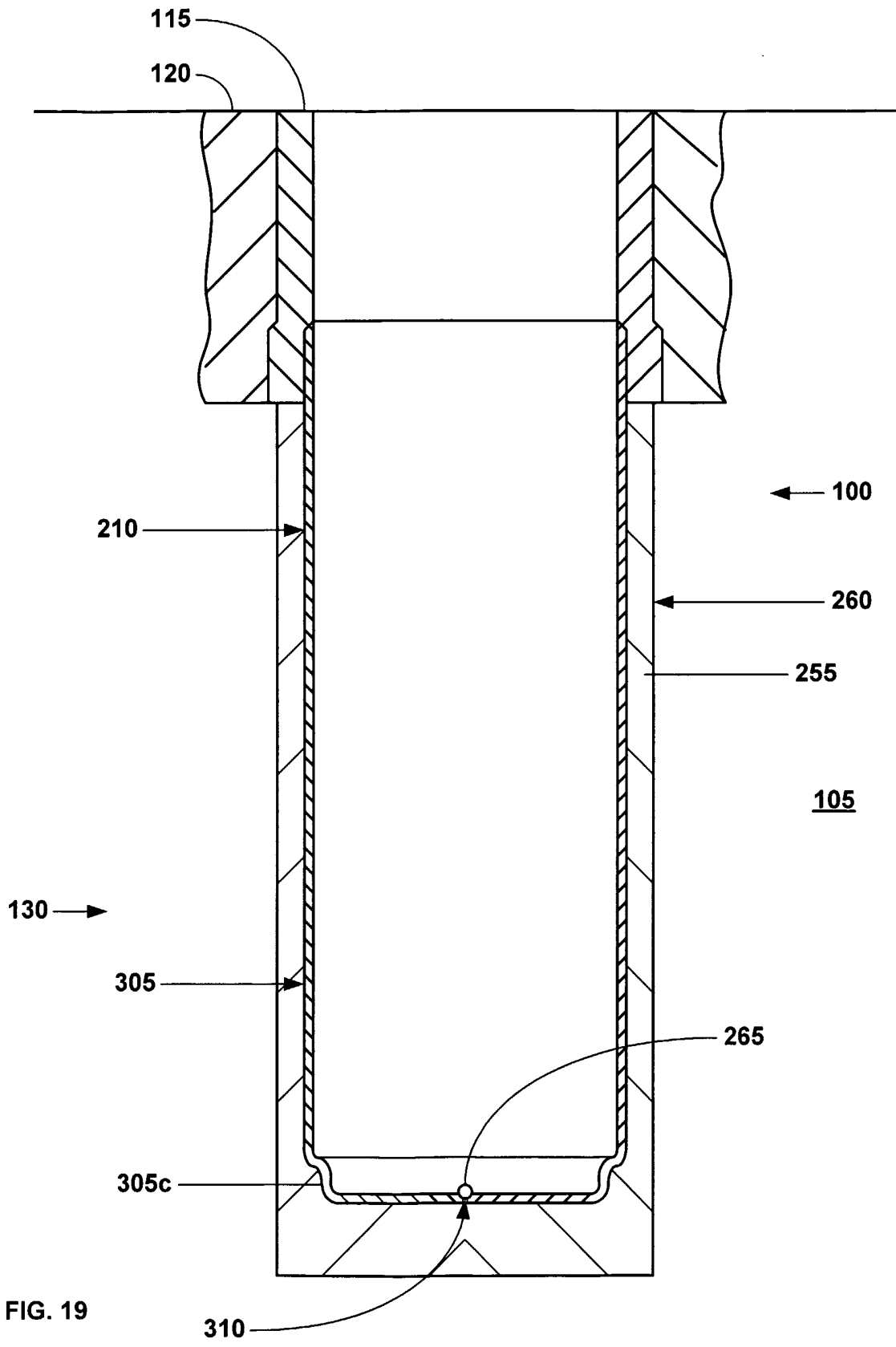

FIG. 19

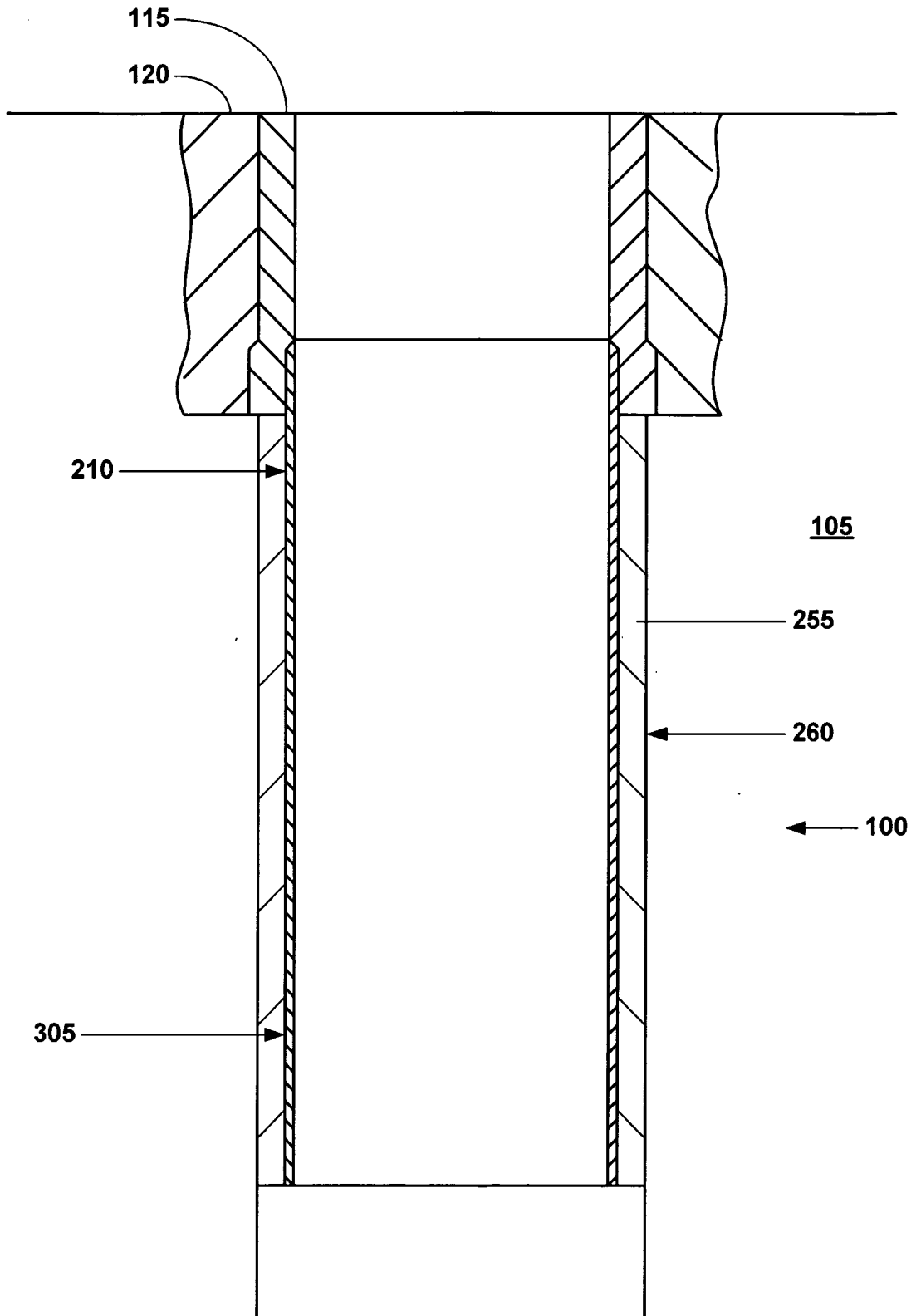

FIG. 20

**INTERNATIONAL SEARCH REPORT**

International application No.

PCT/US02/04353

<b>A. CLASSIFICATION OF SUBJECT MATTER</b>												
IPC(7) : E21B 19/16, 23/00												
US CL : 166/380, 207												
According to International Patent Classification (IPC) or to both national classification and IPC												
<b>B. FIELDS SEARCHED</b>												
Minimum documentation searched (classification system followed by classification symbols) U.S. : 166/380, 207, 85.1, 177.4, 212, 216, 217, 242.1, 378												
Documentation searched other than minimum documentation to the extent that such documents are included in the fields searched												
Electronic data base consulted during the international search (name of data base and, where practicable, search terms used) EAST Text												
<b>C. DOCUMENTS CONSIDERED TO BE RELEVANT</b>												
Category *	Citation of document, with indication, where appropriate, of the relevant passages	Relevant to claim No.										
X	US 6,085,838 A (VERCAEMER et al.) 11 July 2000 (11.07.00), figures 2 and 5-7; abstract; claims 1-12.	33, 69										
---		-----										
Y		1-4, 23-27, 54-58										
Y	US 4,776,394 A (LYNDE et al.) 11 October 1998 (11.10.98), column 1, lines 6-52.	1-4, 23-27, 54-58										
Y	US 6,012,523 A (CAMPBELL et al.) 11 January 2000 (11.01.00), abstract.	2, 24-27, 55-57										
<input type="checkbox"/> Further documents are listed in the continuation of Box C. <input type="checkbox"/> See patent family annex.												
<p>* Special categories of cited documents:</p> <table border="0"> <tr> <td>"A" document defining the general state of the art which is not considered to be of particular relevance</td> <td>"T" later document published after the international filing date or priority date and not in conflict with the application but cited to understand the principle or theory underlying the invention</td> </tr> <tr> <td>"E" earlier application or patent published on or after the international filing date</td> <td>"X" document of particular relevance; the claimed invention cannot be considered novel or cannot be considered to involve an inventive step when the document is taken alone</td> </tr> <tr> <td>"L" document which may throw doubts on priority claim(s) or which is cited to establish the publication date of another citation or other special reason (as specified)</td> <td>"Y" document of particular relevance; the claimed invention cannot be considered to involve an inventive step when the document is combined with one or more other such documents, such combination being obvious to a person skilled in the art</td> </tr> <tr> <td>"O" document referring to an oral disclosure, use, exhibition or other means</td> <td>"&amp;" document member of the same patent family</td> </tr> <tr> <td>"P" document published prior to the international filing date but later than the priority date claimed</td> <td></td> </tr> </table>			"A" document defining the general state of the art which is not considered to be of particular relevance	"T" later document published after the international filing date or priority date and not in conflict with the application but cited to understand the principle or theory underlying the invention	"E" earlier application or patent published on or after the international filing date	"X" document of particular relevance; the claimed invention cannot be considered novel or cannot be considered to involve an inventive step when the document is taken alone	"L" document which may throw doubts on priority claim(s) or which is cited to establish the publication date of another citation or other special reason (as specified)	"Y" document of particular relevance; the claimed invention cannot be considered to involve an inventive step when the document is combined with one or more other such documents, such combination being obvious to a person skilled in the art	"O" document referring to an oral disclosure, use, exhibition or other means	"&" document member of the same patent family	"P" document published prior to the international filing date but later than the priority date claimed	
"A" document defining the general state of the art which is not considered to be of particular relevance	"T" later document published after the international filing date or priority date and not in conflict with the application but cited to understand the principle or theory underlying the invention											
"E" earlier application or patent published on or after the international filing date	"X" document of particular relevance; the claimed invention cannot be considered novel or cannot be considered to involve an inventive step when the document is taken alone											
"L" document which may throw doubts on priority claim(s) or which is cited to establish the publication date of another citation or other special reason (as specified)	"Y" document of particular relevance; the claimed invention cannot be considered to involve an inventive step when the document is combined with one or more other such documents, such combination being obvious to a person skilled in the art											
"O" document referring to an oral disclosure, use, exhibition or other means	"&" document member of the same patent family											
"P" document published prior to the international filing date but later than the priority date claimed												
Date of the actual completion of the international search 22 May 2002 (22.05.2002)		Date of mailing of the international search report <b>24 JUN 2002</b>										
Name and mailing address of the ISA/US Commissioner of Patents and Trademarks Box PCT Washington, D.C. 20231 Facsimile No. (703)305-3230		Authorized officer David Bagnell <i>Diane Smith</i> Telephone No. (703) 308-1113										