



- (51) International Patent Classification:
A61B 10/00 (2006.01) A61B 10/02 (2006.01)
- (72) Inventor; and
(71) Applicant: SHALON, Tidhar [US/US]; 26160 Rancho Manuella Lane, Los Alto Hills, CA 94022 (US).
- (21) International Application Number:
PCT/US2018/033434
- (74) Agent: PATANKAR, Madhavi et al.; Shay Glenn LLP, 2755 Campus Drive, Suite 210, San Mateo, CA 94403 (US).
- (22) International Filing Date:
18 May 2018 (18.05.2018)
- (81) Designated States (unless otherwise indicated, for every kind of national protection available): AE, AG, AL, AM, AO, AT, AU, AZ, BA, BB, BG, BH, BN, BR, BW, BY, BZ, CA, CH, CL, CN, CO, CR, CU, CZ, DE, DJ, DK, DM, DO, DZ, EC, EE, EG, ES, FI, GB, GD, GE, GH, GM, GT, HN, HR, HU, ID, IL, IN, IR, IS, JO, JP, KE, KG, KH, KN, KP, KR, KW, KZ, LA, LC, LK, LR, LS, LU, LY, MA, MD, ME, MG, MK, MN, MW, MX, MY, MZ, NA, NG, NI, NO, NZ, OM, PA, PE, PG, PH, PL, PT, QA, RO, RS, RU, RW, SA, SC, SD, SE, SG, SK, SL, SM, ST, SV, SY, TH, TJ, TM, TN, TR, TT, TZ, UA, UG, US, UZ, VC, VN, ZA, ZM, ZW.
- (25) Filing Language: English
- (26) Publication Language: English
- (30) Priority Data:
- | | | |
|------------|-------------------------------|----|
| 62/509,014 | 19 May 2017 (19.05.2017) | US |
| 62/510,247 | 23 May 2017 (23.05.2017) | US |
| 62/512,719 | 30 May 2017 (30.05.2017) | US |
| 62/517,841 | 09 June 2017 (09.06.2017) | US |
| 62/522,078 | 19 June 2017 (19.06.2017) | US |
| 62/525,183 | 26 June 2017 (26.06.2017) | US |
| 62/528,406 | 03 July 2017 (03.07.2017) | US |
| 62/541,379 | 04 August 2017 (04.08.2017) | US |
| 62/578,289 | 27 October 2017 (27.10.2017) | US |
| 62/595,576 | 06 December 2017 (06.12.2017) | US |
| 62/627,175 | 06 February 2018 (06.02.2018) | US |
- (84) Designated States (unless otherwise indicated, for every kind of regional protection available): ARIPO (BW, GH, GM, KE, LR, LS, MW, MZ, NA, RW, SD, SL, ST, SZ, TZ, UG, ZM, ZW), Eurasian (AM, AZ, BY, KG, KZ, RU, TJ, TM), European (AL, AT, BE, BG, CH, CY, CZ, DE, DK, EE, ES, FI, FR, GB, GR, HR, HU, IE, IS, IT, LT, LU, LV, MC, MK, MT, NL, NO, PL, PT, RO, RS, SE, SI, SK, SM,

(54) Title: DEVICES AND METHODS FOR COLLECTING GASTROINTESTINAL SAMPLES

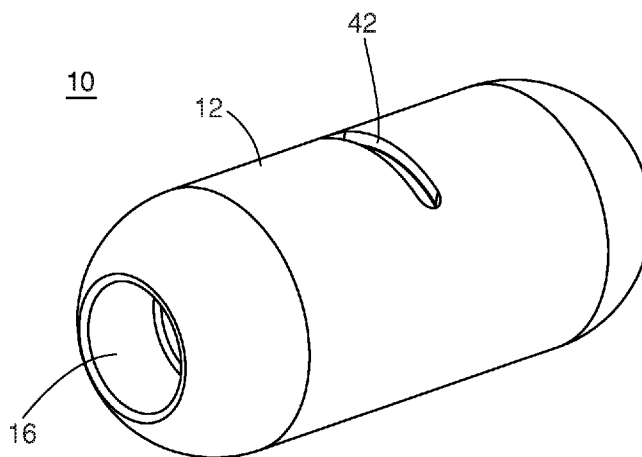

FIG. 2

(57) Abstract: Embodiments of devices and methods for collecting gastrointestinal samples using a capsule-shaped device that is swallowed are provided.



TR), OAPI (BF, BJ, CF, CG, CI, CM, GA, GN, GQ, GW,
KM, ML, MR, NE, SN, TD, TG).

Published:

- *with international search report (Art. 21(3))*
- *before the expiration of the time limit for amending the claims and to be republished in the event of receipt of amendments (Rule 48.2(h))*

DEVICES AND METHODS FOR COLLECTING GASTROINTESTINAL SAMPLES**CROSS REFERENCE TO RELATED APPLICATIONS**

[0001] This application is an international patent application filed under the Patent Cooperation Treaty (PCT), which claims priority to and the benefit of the provisional patent application titled

5 “Devices And Methods For Collecting Gastrointestinal Samples”, application number 62/509,014, filed in the United States Patent and Trademark Office on 19 May 2017, the provisional patent application titled

“Devices And Methods For Collecting Gastrointestinal Samples”, application number 62/510,247, filed in the United States Patent and Trademark Office on 23 May 2017, the provisional patent application titled

10 “Devices And Methods For Collecting Gastrointestinal Samples”, application number 62/512,719, filed in the United States Patent and Trademark Office on 30 May 2017, the provisional patent application titled

“Devices And Methods For Collecting Gastrointestinal Samples”, application number 62/ 517,841, filed in the United States Patent and Trademark Office on 9 June 2017, the provisional patent application titled

“Devices And Methods For Collecting Gastrointestinal Samples”, application number 62/522,078, filed in the United States Patent and Trademark Office on 19 June 2017, the provisional patent application titled

15 “Devices And Methods For Collecting Gastrointestinal Samples”, application number 62/525,183, filed in the United States Patent and Trademark Office on 26 June 2017, the provisional patent application titled

“Devices And Methods For Collecting Gastrointestinal Samples”, application number 62/528,406, filed in the United States Patent and Trademark Office on 3 July 2017, the provisional patent application titled

“Devices And Methods For Collecting Gastrointestinal Samples”, application number 62/541,379, filed in the United States Patent and Trademark Office on 4 August 2017, the provisional patent application titled

20 “Devices And Methods For Collecting Gastrointestinal Samples”, application number 62/578,289, filed in the United States Patent and Trademark Office on 27 October 2017, the provisional patent application

25 titled “Devices And Methods For Collecting Gastrointestinal Samples”, application number 62/595,576, filed in the United States Patent and Trademark Office on 6 December 2017, and the provisional patent application titled “Devices And Methods For Collecting Gastrointestinal Samples”, application number 62/627,175, filed in the United States Patent and Trademark Office on 6 February 2018.

INCORPORATION BY REFERENCE

[0002] All publications and patent applications mentioned in this specification are herein

30 incorporated by reference in their entirety to the same extent as if each individual publication or patent application was specifically and individually indicated to be incorporated by reference.

FIELD

[0003] This application relates to the field of gastrointestinal diagnosis and treatment.

35

BACKGROUND

[0004] It has recently been recognized that mammalian gastrointestinal (GI) tract microbiomes perform many vital physiological functions that benefit their host organism, comprising digestion, producing essential amino acids and vitamins, regulating the immune system, providing resistance to disease, and even modifying appetite, and behavior. Yet we know very little about the functions of hundreds or thousands of microbial species in mammalian GI tracts. The variety of microbes in a single individual at different points of the GI tract is staggering. Due to the complexity of this microbial ecology in a single individual and the variability among individuals, there exists a need to routinely sample and analyze the microbial community living in all regions of the GI tract, along with their associated metabolites, as well as their interactions with the host. The metabolites and secondary metabolites play a key role in the two way communication between the microbes and their hosts and can greatly impact the physiological state of the host. Furthermore, the analyses of the gut microbes can correlate to states of health and disease, as well as guide and measure the effect of treatment.

15

SUMMARY OF THE DISCLOSURE

[0005] The present invention relates to devices and methods for collecting gastrointestinal samples using a capsule-shaped device that is swallowed.

[0006] In an initial aspect, a device for collecting gastrointestinal samples is provided. The device comprises a capsule; and a tube-shaped body wound, twisted or folded within said capsule, the body comprising an open end and a closed end.

[0007] In some embodiments, the tube-shaped body comprises a narrowed portion configured to limit a sampling rate of the device. The tube-shaped body can comprise an internal diameter of about 0.2 to 2.5 mm. In some embodiments, the tube-shaped body comprises an external diameter of about 0.4 to 3.0 mm. In some embodiments, the tube-shaped body comprises an external diameter of about 5.0 to 7.0 mm. The tube-shaped body can comprise a length of about 1 to 200 cm. In some embodiments, the tube-shaped body has an aspect ratio of 5 or greater. In some embodiments, movement of gastrointestinal samples into the tube-shaped body is driven by a pressure differential between a radially collapsed and radially expanded body.

[0008] In some embodiments, the open end of the tube-shaped body can comprise a one way valve. The cracking pressure of the one way valve can be in the range of about 0.03 to 15 pounds per square inch. The maximal outward radial pressure exerted by expanding tube-shaped body can be in the range of about 10 to 150 grams-force per cm length of body. The flow of fluid sample through the open end of the body can be between 1 to 500 microliters per hour.

[0009] Spatial resolution of the sampling of the device can be about +/- 1 foot of a 30 foot long gastrointestinal tract. The tube-shaped body can be hollow. The tube-shaped body can comprise a collapsed internal lumen. In some embodiments, the tube-shaped body is wound as a spiral around a central axis. The spiral can be axially offset around the central axis. In some embodiments, the tube-shaped body is twisted around a central axis to form a helix or coil. The tube-shaped body can be twisted

around a central axis to form a super-helix or super-coil. In some embodiments, the tube-shaped body is folded into an accordion configuration. The tube-shaped body can be folded along a central axis into a creased configuration. The tube shaped body is not invaginated when placed within the capsule. The maximal diameter of the tube-shaped body is smaller than the diameter of the capsule.

5 **[0010]** The tube-shaped body can be configured to transition to its relaxed state upon dissolution of the capsule. In some embodiments, the capsule is ruptured by expansion force of the tube-shaped body. The tube-shaped body can be configured to transition to its relaxed state upon degradation of a covering element on the tube-shaped body. In some embodiments, wherein the capsule comprises one or more covering elements surrounding the tube-shaped body. The capsule can comprise at least a first and a
10 second pH sensitive degradable covering element surrounding the tube-shaped body. In some embodiments, at least one of the first and second covering elements degrades at a pH of about 6.4-7 or lower. The device can be configured to sample gastrointestinal contents for about 1 minute to 1 hour. In some embodiments, the device is configured to sample gastrointestinal contents for about 1 hour to 8 hours. Different portions of the wound, twisted or folded tube-shaped body can comprise different
15 degradable covering elements. In some embodiments, covering elements positioned closer to the open end are configured to degrade faster than covering elements positioned farther from the open end. In some embodiments, covering elements positioned closer to the open end are configured to degrade at a lower pH than covering elements positioned farther from the open end.

[0011] In some embodiments, a second end of the tube-shaped body is in fluid communication with
20 an opening in the capsule.

[0012] The tube shaped body can be coiled to form a plurality of flat disks. In some embodiments, the tube-shaped body is coiled to form three flat disks. Each disk can be configured to uncoil at a different rate to target different portions of the gastrointestinal tract. In some embodiments, the open end is positioned on an inside of the wound, twisted, or folded tube-shaped body. The open end can be
25 positioned on an outside of the wound, twisted, or folded tube-shaped body. In some embodiments, the capsule comprises a split capsule configured to split in the right colon. In some embodiments, the capsule can comprise a tube-shaped body configured to unfold in the right colon. The tube shaped body can comprise an open end of a tube-shaped body configured to open in the right colon.

[0013] A collection volume percentage of the device can be at least 50%. In some embodiments, a
30 collection volume percentage of the device is at least 100%. A dead volume of the device can be less than about 15%. In some embodiments, a volume of the device is less than about 2 ml. The volume of the device can be less than about 1 ml.

[0014] In some embodiments, the device comprises a detector configured to detect a location identification parameter. The location identification parameter can comprise at least one of pH, color,
35 bacterial count, bacterial identity, hormones, dissolved gases, enzymatic activity, biochemical markers, capsule movement patterns, and intraluminal pressure.

[0015] In some embodiments, the device comprises an actuator. The actuator can comprise an elastic material. In some embodiments, the actuator comprises a hollow bladder. The actuator can be

spaced apart from an end of the capsule, creating a space between the actuator and the capsule. In some embodiments, the capsule comprises an orifice that is positioned on the body within the space. The orifice can comprise a movable seal configured to open or close the orifice. In some embodiments, the orifice comprise a degradable covering element. The actuator can comprise a first collapsed state and a
5 second expanded state. The space can comprise a fluid.

[0016] In some embodiments, a length of the tube-shaped body does not change during the sample collection process.

[0017] In another aspect, a method of producing a device for sampling gastrointestinal contents is provided. The method comprises winding, twisting or folding a tube-shaped body; and placing said
10 wound, twisted or folded tube-shaped body inside a capsule.

[0018] In some embodiments, the internal lumen of the wound, twisted or folded tube-shaped body is radially collapsed. The tube-shaped body or an opening of the tube-shaped body can be covered with an enteric degradable material.

[0019] In another aspect, a method of sampling gastrointestinal contents is provided. The method
15 comprises delivering the device of claim 1 into the gastrointestinal tract; allowing flow of gastrointestinal contents into said tube-shaped body; and recovering said device from the stool.

[0020] In some embodiments, radial expansion of the collapsed internal lumen of said tube-shaped body causes said flow of gastrointestinal contents into said tube-shaped body.

[0021] In yet another aspect, a method of sampling gastrointestinal contents is provided. The
20 method comprises delivering a device comprising a capsule; and tube-shaped body wound, twisted, or folded within the capsule, into the gastrointestinal tract; and allowing flow of gastrointestinal contents into the tube-shaped body, and recovering the device from the stool.

[0022] In some embodiments, allowing flow comprises radially expanding the tube-shaped body. In some embodiments, radially expanding the tube-shaped body comprises dissolving the capsule. In some
25 embodiments, radially expanding the tube-shaped body comprises degradation of a covering element on the tube-shaped body or on the capsule.

[0023] In yet another aspect, a device for collecting gastrointestinal samples is provided. The device comprises a body; an opening on a sidewall of the body; a plurality of plates mounted along a spindle running along a longitudinal axis of the body, adjacent plates comprising a space between them; and an
30 actuator configured to displace the plurality of plates along the longitudinal axis of the body, wherein longitudinal displacement causes each space between the plates to align with the opening. The plates can be disk shaped. In some embodiments, the plates comprise a same shape as a cross section of the body and seal against an inner wall of the body. The opening can be slit shaped. The body can be capsule shaped. In some embodiments, the body comprises a covering. The device can comprise a cavity for
35 stool collection. In some embodiments, the actuator comprises an elastic tensile member.

[0024] In another aspect, a device for collecting gastrointestinal samples is provided. The device comprises an outer body; a covering element over the outer body; an opening in a sidewall of the outer body; a hollow piston shaped to mate to an inner surface of the outer body, the piston positioned at an end

of the body; and an actuator configured to advance piston to an opposite end of the body to cover the opening in the sidewall.

[0025] In some embodiments, the device comprises a second opening positioned diametrically opposed to the opening. The device can comprise an opening in the body. In some embodiments, the actuator comprises material that expands when wet. The piston can be cup shaped. In some

[0026] In yet another aspect, a device for collecting gastrointestinal samples. The device comprises a body; a collecting member within the body; and opening on the body; a sealing element movable from a first position where the opening is open to a second position where the opening is sealed by the sealing element; and an actuator configured to move the sealing element.

[0027] In some embodiments, the collecting member comprises a porous material. The actuator can be a wet actuator. In some embodiments, the actuator comprises a dehydrated sponge or superabsorbent material. The device can comprise a wick near the opening. In some embodiments, the collecting member is movable from a first position in which the opening is not in fluid communication with the collecting member to a second position in which the opening is in fluid communication with the collecting member. The collecting member can be movable from a second position in which the opening is in fluid communication with the collecting member to a third position in which the collecting member seals the opening. In some embodiments, the collecting member is the sealing element. The actuator can comprise a moisture degradable restraint mechanism. In some embodiments, the actuator comprises a double trigger moisture degradable restraint mechanism. The actuator can be the sealing element. The device can comprise one or more additional openings. In some embodiments, the actuator comprises a plurality of actuator elements. In some embodiments, the actuator moves the sealing element into a sealing position within about 1-60 minutes. The device can comprise a covering element. In some embodiments, the device comprises a pH sensitive degradable covering element configured to cover the opening. The device can comprise a second opening covered by a second pH sensitive degradable covering element.

[0028] In another aspect, a device for collecting gastrointestinal samples is provided. The device comprises a body; an opening in fluid communication with the body configured to allow gastrointestinal samples to enter the body; and an external pH sensitive degradable covering element covering the opening; and an internal pH sensitive degradable covering element covering the opening.

[0029] In some embodiments, the external covering element is configured to degrade at or above a target pH level. The internal covering element can be configured to degrade at or below a target pH level. In some embodiments, the external covering element is configured to degrade at a pH of about 6.4-7 or above. The internal covering element can be configured to degrade at a pH of about 6.4-7 or below. In some embodiments, the external covering element is configured to dissolve in small intestines. The internal covering element can be configured to dissolve in the right colon. In some embodiments, the external covering element comprises anionic acrylic polymers with methacrylic acid as a functional

group. The internal covering element can comprise cationic polymer with dimethylaminoethyl methacrylate as a functional group.

[0030] In another aspect, a system for collecting gastrointestinal samples is provided. The system comprises a first stomach-targeting capsule; a second small intestine targeting capsule; and a third colon targeting capsule, wherein the three capsules are configured to be ingested at the same time.

[0031] In some embodiments, at least one of the capsules comprises a pH sensitive degradable material configured to degrade at an area to be targeted. At least one of the capsules can comprise an internal pH sensitive degradable covering element and an external pH sensitive degradable material. In some embodiments, at least one of the capsules comprises a degradable covering element with a thickness selected to degrade at an area to be targeted. The capsules can comprise a pH sensitive degradable covering element. In some embodiments, the covering element is configured to degrade at a pH of about 5.5 or higher. The capsules can be connected by a flexible connection element.

[0032] In another aspect, a system of collecting gastrointestinal samples is provided. The system comprises a capsule; a plurality of collecting members each comprising a hollow body within the capsule and a degradable covering element, the collecting members linked together by connecting members to form a chain, wherein filling of a collecting member with sample triggers collection by a subsequent collecting member in the chain. The collecting members can each comprise an opening. The degradation or dissolution of a moisture degradable material exposes the openings of the plurality of the collecting members in a serial manner.

[0033] In some embodiments, a length of each collecting member is about 1-30 mm. A length of each connecting member can be about 1 -100 mm. In some embodiments, the collecting members are arranged linearly or centrally around a spoke. At least some of the collecting members can comprise a seal or one way valve. In some embodiments, a negative pressure differential is used to collect a sample. The negative pressure differential can be caused by capillary forces or expansion of a collapsed member. In some embodiments, the covering element is configured to degrade based on one of hydration time or pH. Filling of a collecting member can trigger closure or sealing of the collecting member. In some embodiments, filling is detected by a target volume, a target duration, or a specific pH. Some of the collecting members can comprise a seal. In some embodiments, some of the collecting members comprise a flow sensor.

BRIEF DESCRIPTION OF THE DRAWINGS

[0034] The novel features of the invention are set forth with particularity in the claims that follow. A better understanding of the features and advantages of the present invention will be obtained by reference to the following detailed description that sets forth illustrative embodiments, in which the principles of the invention are utilized, and the accompanying drawings of which:

[0035] FIG. 1 illustrates the anatomy of the human gastrointestinal tract.

[0036] FIG. 2 illustrates in perspective view of an embodiment of the device.

[0037] FIG. 3 illustrates a cut-away perspective view of an embodiment of the device.

- [0038] FIG. 4 illustrates a sectional view of an embodiment of the device at the commencement of collecting gastrointestinal samples.
- [0039] FIG. 5 illustrates a sectional view of an embodiment of the device after collecting gastrointestinal samples.
- 5 [0040] FIG. 6 illustrates in perspective view of an embodiment of the device comprising the disassembled elements thereof.
- [0041] FIG. 7 illustrates in perspective view of an embodiment of the assembled device.
- [0042] FIG. 8 illustrates a perspective view of an embodiment of the device prior to collecting any gastrointestinal samples.
- 10 [0043] FIG. 9 illustrates a cut-away perspective view of an embodiment of the device prior to collecting any gastrointestinal samples.
- [0044] FIG. 10 illustrates a cut-away perspective view of an embodiment of the device after collecting gastrointestinal samples.
- [0045] FIG. 11 illustrates a sectional view of an embodiment of the device prior to collecting any
15 gastrointestinal samples.
- [0046] FIG. 12 illustrates a sectional view of an embodiment of the device after collecting gastrointestinal samples.
- [0047] FIG. 13 illustrates a perspective view of an embodiment of the device prior to collection of gastrointestinal samples.
- 20 [0048] FIG. 14 illustrates a perspective view of an embodiment of the device during collecting gastrointestinal samples.
- [0049] FIG. 15 illustrates a perspective sectional view of an embodiment of the device after collecting gastrointestinal samples.
- [0050] FIG. 16 illustrates a perspective view of an embodiment of the device prior to collection of
25 gastrointestinal samples.
- [0051] FIG. 17 illustrates a perspective view of an embodiment of the device during collecting gastrointestinal samples.
- [0052] FIG. 18 illustrates a perspective sectional view of an embodiment of the device after collecting gastrointestinal samples.
- 30 [0053] FIG. 19 illustrates a sectional view of an embodiment of the device configured as a segmented series of discrete collecting members.
- [0054] FIG. 20 illustrates an enlarged sectional view of one of the collecting members of the embodiment shown in Fig. 19.
- [0055] FIG. 21 illustrates a perspective view of a multiple collection element embodiment of the
35 device prior to collecting any gastrointestinal samples.
- [0056] FIG. 22 illustrates a perspective view of an embodiment of the device prior to collection of gastrointestinal samples.

- [0057] FIG. 23 illustrates a perspective sectional view of an embodiment of the device prior to collection of gastrointestinal samples.
- [0058] FIG. 24 illustrates a perspective sectional view of an embodiment of the device during collection of gastrointestinal samples.
- 5 [0059] FIG. 25 illustrates a perspective sectional view of an embodiment of the device after collection of gastrointestinal samples.
- [0060] FIG. 26 illustrates a perspective view of an embodiment of the device prior to collection of gastrointestinal samples.
- [0061] FIG. 27 illustrates a perspective sectional view of an embodiment of the device prior to
10 collection of gastrointestinal samples.
- [0062] FIG. 28 illustrates a perspective sectional view of an embodiment of the device during collection of gastrointestinal samples.
- [0063] FIG. 29 illustrates a perspective sectional view of an embodiment of the device after collection of gastrointestinal samples.
- 15 [0064] FIG. 30 illustrates a cut-away perspective view of an embodiment of the device prior to potential energy being stored in the actuator.
- [0065] FIG. 31 illustrates a cut-away perspective view of an embodiment of the device with potential energy stored in the actuator and prior to collecting any gastrointestinal samples.
- [0066] FIG. 32 illustrates a cut-away perspective view of an embodiment of the device after
20 collecting gastrointestinal samples.
- [0067] FIG. 33 illustrates a partial sectional perspective view of an embodiment of the device configured as spools of wound collecting members with individual covering elements.
- [0068] FIG. 34 illustrates a sectional perspective view of an embodiment of the device configured as a single segmented collecting member.
- 25 [0069] FIG. 35 illustrates an embodiment of a collecting member with a collapsed lumen wound as a spiral around a central axis.
- [0070] FIG. 36 illustrates an embodiment of a collecting member with a collapsed lumen wound as a spiral with axial offset around a central axis.
- [0071] FIG. 37 illustrates an embodiment of a collecting member with a collapsed lumen folded in
30 an accordion fold configuration.
- [0072] FIG. 38 illustrates an embodiment of a collecting member with a collapsed lumen twisted into a helix or coil configuration.
- [0073] FIG. 39 illustrates an embodiment of a collecting member with a collapsed lumen folded into a creased configuration.
- 35 [0074] FIG. 40 illustrates an embodiment of the device with an active valve, pH sensor and flow sensor.

DETAILED DESCRIPTION

[0075] As used herein, the terms “analysis”, “analyses” and “analytical techniques” refer to techniques comprising pH measurement, visual inspection, spectral analysis, pressure measurement, oxygen content, colorimetry, phylogenetic, proteomic, metabolomics, mass spectrometry (MS), nuclear magnetic resonance (NMR), chromatography, electrophoresis, presence of hemoglobin, immunoassay, protein-protein interactions, fluorescence, flow cytometry, host-microbiome interactions, nucleic acid hybridization, mRNA or cDNA transcription analysis, and sequencing of nucleic acids comprising entire genomes, random fragments, or specific sections such as the 16S rRNA of microbes and any combination of the techniques above, whether in parallel or sequentially. Overlaying all or a subset of these analyses on top of clinical or phenotypical information will provide a comprehensive picture of the physiology of the GI tract and the state of the microbiome in health and disease, as well as the safety and efficacy of treatment. The ability to combine information about the identities and diversity of microbial community members obtained from 16S rRNA sequencing, the metabolic potential obtained from meta-genome sequence data, and gene expression and protein production obtained from meta-proteome data, enables exploration of the gut microbiota at multiple molecular levels simultaneously.

[0076] As used herein, the term “gastrointestinal samples” comprises liquids, digestive juices, mucus, microbes, metabolites, cells, cell fragments, carbohydrates, fats, lipids, proteins, peptides, immune system molecules, immune system cells, blood, hemoglobin, food particles, acids, bases, gases, small molecules, hormones, nucleic acids, drugs, pro-drugs, drug metabolites, volatile molecules, dissolved or free gases, and other molecules present in the GI tract from the mouth to the anus. As used herein, the term “microbe” comprises one or more species or strains of microscopic agents from the three domains eubacteria, eukarya and archaea as well as viruses such as phages. As used herein, a group of microbes, or a microbial population, taken as a whole is referred to as a “microbiota” and when the group is quantitated or measured in some manner it is referred to as a “microbiome.” As used herein, the terms “immune system molecules or immune system cells” comprise all forms of lymphocytes, leukocytes, antigen-presenting cells, antibodies, antigens, markers of inflammation, c-reactive protein (CRP), antimicrobial molecules, proteases, cell signaling proteins, cytokines, chemokines, hormones, neurotransmitters, interleukins, vitamins, major histocompatibility (MHC) molecules, complement system molecules, anti-viral molecules, and the like.

[0077] As used herein, the term “degradable material” comprises “moisture degradable material” and also “enteric degradable material” as described more fully below.

[0078] As used herein, the term “moisture degradable material” means a material that dissolves, degrades, hydrolyzes, hydrates, softens, or otherwise loses strength when exposed to moisture at a broad range of pH levels, or in a narrow range of pH levels, at a broad range of times or in a narrow range of times, and in the presence or absence of human or microbial enzymes that can metabolize or degrade such a material. Moisture degradable materials comprise polyvinyl alcohol (PVA), polyvinyl acetate phthalate (PVAP), polyvinyl chloride, polyvinylpyridine acrylic acid, fatty acids, waxes, shellac, plant fibers, paper,

cellulosic material, starch, methyl acrylate-methacrylic acid copolymers, cellulose acetate phthalate (CAP), cellulose acetate succinate, hydroxypropyl methyl cellulose phthalate, hydroxypropyl methyl cellulose acetate succinate, methyl methacrylate, methacrylic acid, polyacryl, cellulose acetate, trimellitate, sodium alginate, zein, starch, pectin, gelatin, cross-linked gelatin, carbohydrates, gum arabic, salts, sodium hypochlorite, lithium hypochlorite, calcium hypochlorite, dichlor, trichlor, sugars, proteins, hydrogels, as well as polymers, copolymers, acetates, sheets, coatings, foams, mixtures, or derivatives thereof. The functionalities of the moisture degradable material comprise protecting the device from exposure to gastrointestinal content until the desired location in the GI tract is reached, allowing motion of the actuator to start or stop the sampling of gastrointestinal fluids after sufficient sample has been collected, and/or acting as a sanitizing bactericide to stop all metabolic processes when dissolved in the collected samples. By way of example, solid salt such as sodium chloride that is in fluid communication with the collecting member will dissolve when gastrointestinal fluids are introduced into the sampling capsule. The solid salt acts to resist the motion of an actuator. When dissolved, the salt can no longer physically prevent the sealing of the sampling capsule by the actuator. Furthermore, the resulting high dissolved salt concentrations in the collecting member kills the microbes in the device, thereby helping preserve the biomolecules therein for analysis at a later time.

[0079] As used herein, the term “enteric degradable material” refers to compounds and coating techniques that enable the collecting member of a device to only come into fluid communication with a portion of the GI tract that is distal to the stomach. Sample enteric degradable materials comprise methyl acrylate-methacrylic acid copolymers, cellulose acetate phthalate (CAP), cellulose acetate succinate, hydroxypropyl methyl cellulose phthalate, hydroxypropyl methyl cellulose acetate succinate (hypromellose acetate succinate), polyvinyl acetate phthalate (PVAP), methyl methacrylate-methacrylic acid copolymers, shellac, cellulose acetate trimellitate, sodium alginate, zein, and combinations or derivatives thereof. The enteric degradable materials disclosed herein control the flow of fluid into a device at a point distal to the stomach. This is in contrast to enteric and enteric delivery technologies used in drug delivery that control the flow of substances out of the capsule and into the body at a point distal to the stomach. For example, flow of substances out of a capsule can be achieved via diffusion through a swollen and hydrated, but not dissolved, enteric coating. In contrast, flow of gastrointestinal samples into a device requires bulk flow of liquid into the device through a fully dissolved or ruptured coating. Therefore, enteric coatings that work for drug delivery may not work well for controlling the function of a sample collection device. By way of example, the sampling device can be made of an elastic material that is compacted inside a delivery capsule, which is then coated by an enteric degradable material. The elastic sampling device exerts radial or axial pressure on the enteric coating from the inside the capsule to rupture the enteric coating and start bulk flow of liquid samples into the sampling device.

[0080] Enteric degradable materials further comprise timed release or time degradable materials that degrade mainly after the device has had sufficient time to traverse the small intestines and enter into the colon. By way of example, a device is coated with a time release coating such as guar gum and then further coated with an enteric degradable material such as methacrylic acid that only dissolves at a pH

present in the small intestine. The external enteric degradable material protects the device during the transit through an acidic stomach. The enteric degradable material degrades in the pH of the small intestine, thereby exposing the next coating of guar gum. The guar gum coating takes 2 hours to degrade which protects the device through the remaining 2 hour transit through the small intestines. Finally, when the guar gum coating degrades in the colon, the device collects a gastrointestinal sample in the colon. As used herein, the term “colonic targeting” refers to compounds and coating techniques that enable the collecting member of a device to only come into fluid communication with a portion of the GI tract that is distal to the small intestine. Colonic targeting materials comprise materials that are preferentially degraded at pH levels, gas content, color, lumen size, enzymes, metabolism or microbes that are preferentially present in the colon relative to the small intestines. Example materials that are useful coatings for colonic targeting comprise methacrylic acid, methyl methacrylate-methacrylic acid copolymers, starch, pectin, chitosan, guar gum, dextran, and combinations or derivatives thereof.

[0081] As used herein, the term “porous” means any open cell structure. Such materials comprise open cell foams, fibers, channeled materials, papers, cellulotics, acetates, cotton, cloth, gauze, sponges and the like.

[0082] As used herein, the term “active agent” comprises drugs, pro-drugs, nutritional supplements, prebiotics, probiotics, postbiotics, synbiotics, microbes, immune system molecules, immune system cells, immune system modifiers, dyes, combinations of the above, and the like. As used herein, the term “hydrophilic” means water forms a contact angle of less than 90 degrees on a surface. As used herein, the term “superhydrophilic” means water forms a contact angle of less than 1 degree on a surface.

[0083] Unless otherwise defined, all technical and scientific terms used herein have the same meaning as commonly understood by one of ordinary skill in the art to which this invention belongs. Although methods and materials similar or equivalent to those disclosed herein can be used in the practice of the present invention, suitable methods and materials are disclosed below. In case of conflict, the patent specification, including definitions, will control. In addition, the materials, methods, and examples are illustrative only and not intended to be limiting.

[0084] Before explaining at least one embodiment of the invention in detail, it is to be understood that the invention is not limited in its application to the details of construction and the arrangement of the components set forth in the following description. The invention is capable of other embodiments or of being practiced or carried out in various ways. Also, it is to be understood that the phraseology and terminology employed herein is for the purpose of description and should not be regarded as limiting.

[0085] Figure 1 shows the regions of the human gastrointestinal (GI) tract that are sampled by the device and methods described herein. Food enters stomach **1** where muscles mix the food and liquid with digestive juices. The stomach slowly empties its contents, called chyme, into the duodenum **2**, also referred to as the proximal portion of the small intestine. The muscles of the small intestine mix food with digestive juices from the pancreas, liver, and intestine, and push the mixture forward into the jejunum **3**, also referred to the mid portion of the small intestine, for further digestion. The walls of the small intestine absorb water and the digested nutrients into the bloodstream until the ileum **4**, also referred to as the distal

portion of the small intestine, is reached. As peristalsis continues, the waste products of the digestive process move into the ascending colon **5**, also referred to as the right colon or proximal colon portion of the large intestine where complex carbohydrates are fermented by microbes. Waste products from the digestive process include undigested parts of food, fluid, and older cells from the lining of the GI tract get transferred into the transverse colon **6**, also referred to as the mid colon. The descending colon **7**, also referred as the left colon or distal colon portion of the large intestine absorbs water and changes the waste from liquid form into solid stool. Peristalsis helps move the stool into rectum **8** and from there into the toilet during a bowel movement. The pH levels and other biochemical and physical differences between these regions of the GI tract are described more fully in tables 1 and 4.

[0086] Most of the microbial activity occurs in the small intestine and right colon, which are the prime regions of sample collection. The inventor has determined experimentally that fermentation activity of the microbes is reduced after stool arrives in the transvers colon. Based on the typical transit times listed in Table 1 below, the desired sampling window time is up to 8 hours, which is long enough for the sampling device to reach the right colon. After the right colon, the collected samples are not significantly different than a stool sample collected outside the body.

[0087] Many of the microbes and other gastrointestinal samples of interest reside in the mucus layer on the GI tract's lumen. At any given point in time, a region of the GI tract can be empty and collapsed, contain gas, fluid, semisolid content, solid content, or a mixture of each. When a region of the GI tract is full of gas, the collecting member can be sitting on an exposed lumen wall without any surrounding free-flowing fluid. It is preferable that the collecting member not only be able to collect surrounding fluid, but also be able to collect, wick or absorb through direct contact or capillary action the gastrointestinal samples in the form of a thin layer of mucus on the lumen surface that doesn't flow easily. Prior art capsule collection devices rely on vacuum chambers, indentations or invaginated collection chambers that are designed to fill up with free-flowing gastric fluids. But intestinal gas, rather than free-flowing fluids, may exist in the surrounding of the capsule at that particular region of the GI tract at the moment of sampling by the device. Therefore, prior art devices that rely on a vacuum, indentations or invaginated collection chambers would only suck in the gas content or not collect any liquid sample at all. Therefore, these prior art collection devices would not be effective in sampling the areas of the GI tract that do not contain large amounts of fluid at the time the capsule is sampling the area. For example, if flow into the sampling opening of the collecting member is driven by a vacuum reservoir, then as soon as the sampling opening is exposed to gas, the gas will flow into collecting member extremely quickly relative to a more viscous fluid sample, thereby filling the collecting member with gas almost instantaneously. The sampling rate of the present disclosure can be relatively unaffected by the viscosity of the material being sampled due to the independently-controlled rate of actuator displacement, reservoir re-inflation, unwinding or unfolding of the collecting member, or the wicking action of the collecting member. In some embodiments utilizing a positive displacement collecting mechanism, for every unit of volume that the actuator is displaced, an equal unit of volume of sample is collected, independent of whether the sample collected is gas or fluid in nature. In some embodiments of a wound and collapsed elastic lumen forming the

collecting member, the rate of unwinding and expansion of the collapsed lumen is controllable by the size of the sampling opening and/or the rate of degradation of the degradable material that restricts unwinding and expansion of the elastically collapsed lumen. It is important to control the rate of sample collection into collecting member to be between 1 to 60 minutes to ensure that a liquid sample is obtained. Even if
5 the device is in the colon, which is full of gas and liquid, the peristaltic forces moving the device around randomly will cause the opening to contact a patch of liquid at some point during the 1 to 60 minute time window. In some embodiments where the sample collection occurs in less than 1 minute, the device might collect only a sample of gas. In some embodiments where the sample collection occurs over more than 60 minutes, then the location specificity of where the sample is collected is lost since the device can travel to
10 a different region of the GI tract in one hour.

[0088] In embodiments wherein the collecting member creates capillary or wicking forces, the surface tension of gastrointestinal fluids interacting with the collecting member allows for only liquid gastrointestinal samples to be collected. Gas in the collecting member will be easily displaced by liquids since the surface tension of a gas is far less than that of a fluid.

15 **[0089]** In some embodiments, the device or collecting member does not expand in volume or rely on a pressure differential in order to collect a gastrointestinal sample. Rather, wicking or capillary forces alone drive the collection of gastrointestinal samples into a collecting member.

[0090] In some embodiments, the device or collecting member grows smaller in overall volume during the collection process of a gastrointestinal sample. The reduction in overall volume displaces
20 trapped gas present in the device and/or enables a sealing action to isolate the collected gastrointestinal sample from further contact with the GI tract. This embodiment is in contrast to prior art devices that expand in overall volume to create a negative pressure differential that drives samples into the device.

[0091] In some embodiments, the capsule is the size and shape of a size 3, 2, 1, 0, 00 or 000 capsule.

[0092] In some embodiments, the collecting member comprises the wet, dried or lyophilized reagents
25 required for cell lysis. Example reagents required for cell lysis when rehydrated by the gastrointestinal sample comprise sodium dodecyl carbonate, tris (2-carboxyethyl) phosphine, 2-chloroacetamide, and/or tris buffer pH 8.5. In this manner, the cell contents are released into the collecting member and enzymatic activity will cease and the cell contents are thus prepared for further analysis techniques in-vivo or ex-vivo.

30 **[0093]** In some embodiments, the collecting member comprises the wet, dried or lyophilized reagents required for protein digestion. Example reagents required for protein digestion comprise trypsin and Lys-C protease. In this manner, enzymatic activity will cease and the proteins are thus prepared for a further analysis techniques in-vivo or ex-vivo. An example analysis step comprises mass spectrometry.

[0094] In some embodiments, the collecting member comprises the wet, dried or lyophilized reagents
35 required for a reverse transcription reaction of the RNA contained in the gastrointestinal samples in real time while the device is still in the GI tract. The RNA in the gastrointestinal samples are labile and may degrade in the time between when the gastrointestinal samples are collected and when they are analyzed, which might be a matter of days. The product of reverse transcription is first strand complementary DNA

(cDNA) which is much more stable. The reagents required for reverse transcription comprise reverse transcriptase, random or specific primers, ligation enzymes, deoxynucleotides (dNTP), RNase inhibitor, salts and buffers.

[0095] In some embodiments, the collecting member comprises wet, dried or lyophilized RNase inhibitor to minimize the degradation of mRNA until the gastrointestinal sample can be analyzed.

[0096] In some embodiments, a capsule body has a through hole as a collecting member. The through hole can create at least two openings in the capsule body. A cover made from a moisture degradable material, an enteric degradable material or a physically moveable cover creates a seal over one or more of the openings of the solid capsule body. At the correct sampling location, the through hole is exposed to the surrounding GI tract environment. Gastrointestinal samples flow or are wicked into the through hole. At the end of sampling, the openings in the solid capsule body are either left open or sealed to contain the gastrointestinal sample therein. If the holes are small enough, they would not need to be sealed after sampling since solid stool will impact itself on the capsule surface and seal the holes further down the digestive track.

[0097] In some embodiments, the solid capsule has multiple such holes and multiple such covers.

[0098] In some embodiments, an external concentric cylindrical sleeve forms the external cover and provides a fluid-tight seal of the two openings in the solid capsule body, thus preventing the through hole from being in fluid communication with GI tract. The external sleeve also comprises two diametrically opposed holes and when the external sleeve is rotated, these holes in the sleeve line up with the two openings in the solid capsule body. In this position, a gastrointestinal sample flows, is wicked or is absorbed into the through hole in the solid capsule body, while allowing gas contained therein to escape in either direction. After sufficient sampling time, the external sleeve rotates again and covers the two openings in the solid capsule body with a fluid-tight seal, thus preventing leakage or contamination of the collected gastrointestinal sample.

[0099] The through-hole feature in the embodiment above allows the gas inside the hole to escape easily as the gastrointestinal sample is being drawn into the hole due to capillary action. A blind hole will have a bubble of gas trapped at the bottom that may prevent sample from being drawn into the hole. An indentation in the capsule will not have the narrow straw-like shape that will enable capillary action to draw in the gastrointestinal sample.

[0100] In some embodiments, the collecting member contains a porous or water soluble substance or channels to enable wicking or diffusion of the gastrointestinal sample into the collecting member. In this embodiment, the collecting member can be a blind hole, since the gastrointestinal samples flow in via capillary action or diffusion versus bulk flow, and trapped gas can escape easily through the porous or water soluble collecting member. Example water soluble materials comprise solid or liquid forms of sugars, salts, polyvinyl alcohol, polyethylene glycol, lactose anhydride and the like. For example, a collecting member filled with solid particles of polyethylene glycol will pull into it the liquid of the gastrointestinal sample, thereby filling the collecting member with the liquid gastrointestinal sample as the water soluble material dissolves. A collecting member filled with a hyperosmotic salt solution or a

material more hygroscopic than the GI samples themselves will draw into the collecting member a liquid gastrointestinal sample via osmotic or hydration forces. Water soluble materials such as polyethylene glycol or salts do not generally interfere with further analysis of the gastrointestinal sample, or can be removed later as part of the sample purification and preparation step. The rate of dissolution and/or the rate of diffusion of the water soluble material out of the device can be used to also control the rate of sampling of the gastrointestinal fluids into the device. Each sample should be collected in a time window of 1 to 60 minutes.

[0101] In some embodiments, the sampling opening in the body is sealed and only opens at a predetermined time or under predetermined conditions, such as a certain pH range or pressure level. The opening then reseals after a predetermined time to prevent further exposure of the collecting member to additional gastrointestinal samples. In some embodiments, a series of such openings is positioned around the outer surface of the capsule to enable multiple collection times, or sampling under multiple conditions.

[0102] In some embodiments, the actuator is a spring or elastic member that is pre-loaded prior to the patient swallowing the capsule. Immediately before swallowing or during the act of swallowing, or at a time period after swallowing, the spring or elastic member starts to perform work as an actuator. In some embodiments, the actuator moves a collecting member relative to the opening in the body at a predefined rate. In some embodiments, the actuator moves the external cover across or around the capsule surface thereby sealing, or alternatively exposing the opening of a hole that forms a collecting member. Examples of springs or elastic member comprise linear and rotary springs made of metal or a polymer, such as a twisted or stretched polymeric band or elongated element.

[0103] In some embodiments, the spring is connected to a gear, ratchet, an escapement mechanism, a pendulum, rotary or linear damper, an element pushing or pulling a gas or fluid through an orifice, and/or a balance wheel to control the speed of rotation or displacement of the actuator over a predefined time period.

[0104] In some embodiments, the device comprises a battery that provides current to microchip circuit that makes quartz crystal vibrate. The microchip circuit detects the crystal's oscillations and turns them into regular electric pulses that open and/or close an active valve at the sampling opening, or drive a miniature electric stepping motor. The stepping motor converts electrical energy into mechanical power that serves as an actuator for the device.

[0105] In some embodiments, a pre-loaded spring or elastic actuator is prevented from doing work or stopped intermittently from doing work, by a removable mechanical restraint. In this manner, the removable mechanical restraint allows the spring or elastic actuator to fully or partially unwind or relax before the next mechanical restraint is reached. Example mechanical restraints include a safety latch, a trigger, a solenoid pin under electronic control, a piezoelectric element, or a moisture degradable element before exposure to moisture. In this manner, the energy to control the release of mechanical work of a spring or elastic actuator is much less than the energy stored in the spring or elastic actuator itself.

[0106] In some embodiments, the actuator can be powered by an onboard energy source such as a battery or capacitor.

[0107] In some embodiments, the actuator is driven by osmotic pressure. After swallowing, water enters a section of the capsule containing hygroscopic material such as a salt via a semipermeable membrane, which creates osmotic pressure that moves the actuator.

[0108] In some embodiments, the linear actuator is the osmotic material itself expanding inside one end of the device, wherein fluid enters the device through a small hole. As the osmotic material expands due to fluid intake, it acts as an actuator.

[0109] In some embodiments, the actuator displaces a valve stem that temporarily opens a sampling opening to be in fluid communication with a collecting member. Example means of establishing fluid communication comprise a through hole in a solid valve stem that is temporarily aligned with the sampling opening. Further displacement of the solid valve stem and subsequent lack of alignment of the hole with the sampling opening seals the sample in the collecting member.

[0110] In some embodiments, multiple sampling openings are connected to separate collecting members. The multiple sampling openings are arranged in a manifold and the displaced valve stem opens and closes each sampling opening in a serial manner one after the other, thereby sampling different regions of the GI tract as the sample device is moved through the GI tract due to peristalsis over a time period of 1 minute to 8 hours.

[0111] In some embodiments, multiple sampling openings are connected to separate collecting members. The multiple sampling openings are arranged in a manifold and a moisture degradable material prevents fluid communication between each sampling opening and the associate collecting member. The moisture degradable material dissolves or degrades along one face or one direction only, similar to the burning of a fuse, so that the sampling openings are exposed in a serial manner one after the other, thereby sampling different regions of the GI tract as the sample device is moved through the GI tract due to peristalsis over a time period of 1 minute to 8 hours. By way of example, the moisture degradable material is in the form of a long thin cylinder placed inside an open ended sleeve that exposes only one round face of the cylinder to the fluids of the GI tract. The sampling openings are arranged in a line along the long edge of the sleeve in a manifold pattern. As the face of the moisture degradable material dissolves or is degraded in the axial direction towards the closed end of the sleeve, the sampling openings are exposed to fluid communication with the GI tract in a sequential manner, thereby sampling the GI tract in a predefined sequence and with a controllable delay between sampling events that is set by the dissolution or degradation time of the exposed face of the moisture degradable material.

[0112] In some embodiments, the actuator is a hydrogel that swells when exposed to water. Example hydrogels comprise sodium polyacrylate.

[0113] The osmotic or hydrogel agent can be selected or designed to expand as a function of various pH levels in order to optimize sampling at specific regions of the GI tract. For example, an osmotic or hydrogel material that expands more rapidly at low pH will utilize more the collecting members to sample the stomach contents relative to the rest of the GI tract. Alternatively, an osmotic or hydrogel material that expands more rapidly at high pH will utilize more the collecting members to sample the distal small intestine contents relative to the rest of the GI tract.

[0114] In some embodiments, the device comprises a linear actuator that pushes or pulls stacked collecting members in an axial direction through the inside volume of the device underneath an opening in the middle region of the device. As successive collecting members are pushed or pulled underneath the opening, they are in turn exposed to the GI tract and absorb, wick or otherwise collect within them
5 gastrointestinal samples. Between each collecting member is a fluid impervious element that prevents axial flow between the stacked collecting members. The fluid impervious element also prevents flow of the gastrointestinal fluid between the outer perimeter of the collecting member and the inner surface of the device. In this embodiment, the stacked collecting members start in one half of the device and move in an axial fashion to the second half of the device. The opening that exposes the collecting member to the GI
10 tract is in the middle region of the device so that each collecting member passes underneath it once.

[0115] In some embodiments, the stacked collecting members are the spaces between thin disks of fluid impervious material mounted on a central stem. Each disk forms a fluid-tight seal against the inner surface of the body, yet is axially displaceable when pushed or pulled by the actuator. In this fashion, a succession of collecting members can be exposed to the GI tract under the opening.

[0116] With reference to the embodiment shown in Figure 2, device **10** is shown in perspective view. Device **10** comprises body **12** with opening **42**. Cavity **16** is used to allow compacted solid or semi-solid stool to enter into an invagination in body **12** to be included in the sample collected, since solid or semi-solid stool is unlikely to enter into the narrow opening **42**.

[0117] In Figure 3, device **10** is shown in perspective view with body **12**, collecting members **18** and thin disks **20** in section view. In Figure 4, device **10** is shown in a cross section side view. Collecting members **18** are shown as a series of spaces between thin disks **20** made of fluid impervious material mounted on a central stem in the form of a spindle. Each thin disk **20** forms a fluid-tight seal against the inner surface of body **12**. Each disk **20** is axially displaceable when pushed by the actuator **24**. In this example, actuator **24** is a hydrogel or osmotic material that is in its initial unexpanded state. The material
25 of actuator **24** expands when body fluids enter body **12** via hole **22**. In this fashion, a succession of collecting member **18** is exposed to the GI tract under opening **42** when actuator **24** expands. In Figure 5, actuator **24** is in its maximally expanded position. The gastrointestinal samples in each collecting member **18** are isolated from one another via thin disks **20**.

[0118] In some embodiments, actuator **24** is a tensile elastic member that pulls collecting member **18**
30 towards the end of body **12**. The rate of motion of collecting member **18** is determined by the elasticity of actuator **24**, the friction between the inner surface of body **12** and collecting members **18** and/or thin disks **20**, and the resistance of flow of a gas or fluid present in body **12** to the outside environment through hole **22**, which in this instance is a venting hole.

[0119] In some embodiments, the stacked collecting members are disks made from a porous material
35 separated with disks of a fluid impervious material. Each fluid impervious disk forms a fluid-tight seal against the inner surface of the device, yet the stack of collecting members is axially displaceable when pushed or pulled by the actuator.

[0120] With reference to another embodiment shown in Figure 6, the disassembled components of device 10 are shown in perspective view. Device 10 comprises body 12 with opening 42, hole 22, and piston 26 that is impervious to fluids, shaped like a cup with an internal volume that forms collecting member 18, actuator 24, and covering element 30 made from a moisture degradable material in the form of a hollow sleeve. Figure 7 shows device 10 in perspective view fully assembled before swallowing with piston 26 and actuator 24 (not visible) inside body 12, and covering element 30 sealing opening 42 and hole 22 (not visible) from contact and/or fluid communication with the GI tract.

[0121] After swallowing device 10, covering element 30 degrades at a predetermined time or pH in the GI tract, thereby exposing opening 42 and hole 22 to contact and/or fluid communication with the GI tract. Figure 8 shows device 10 in perspective view fully assembled after degradation and elimination of covering element 30, but before collection of a gastrointestinal sample. Piston 26 and collecting member 18 are visible through opening 42 and actuator 24 are visible through hole 22. Figure 9 shows device 10 in perspective view at this same time point with body 12 in section view to expose the components therein. The left half of body 12 and the inner cup-shaped volume of hollow piston 26 collectively form collecting member 18. There are two diametrically opposed openings 42 in order to allow trapped gas inside collecting member 18 to escape while gastrointestinal samples flow in through opening 42.

Actuator 24 rests against the closed side of cup-shaped piston 26. At this stage, collecting member 18, which is the hollow volume inside body 12 and hollow piston 26 starts to collect gastrointestinal samples. Also at this stage, actuator 24, which is material that expands when wet, starts to push piston 26 axially due to the fluids in the GI tract flowing through hole 22 and wetting actuator 24.

[0122] Figure 10 shows device 10 in isometric view after the collection of a gastrointestinal sample with body 12 in section view to expose the components therein. Piston 26 has been displaced axially to the left side of body 12 by actuator 24, which is at its fully expanded state. The left half of body 12 and the inner cup-shaped volume of hollow piston 26 collectively form collecting member 18 that contains the collected gastrointestinal sample. Collecting member 18 is now sealed off from opening 42 by a seal formed between piston 26 and body 12. Device 10 is recovered from the GI tract in this state and the gastrointestinal sample within collecting member 18 is extracted from device 10 for further analysis.

[0123] In some embodiments, fluid that actuates actuator 24 enters through opening 42 once covering element 30 is removed so that actuator 24 only starts moving once a gastrointestinal sample has been collected by collecting member 18. For example, fluid entering opening 42 flows between piston 26 and the inner surface of body 12 to reach actuator 24. Actuator 24 is a material that expands when wet.

[0124] In some embodiments, collecting member 18 is a porous or water soluble material that fits at least partially within the hollow volume of piston 26 and causes the gastrointestinal samples to flow, wick or diffuse into collecting member 18.

[0125] In some embodiments, piston 26 is replaced with a porous collecting member 18 that has structural rigidity in the form of open-cell foam or dehydrated hydrogel. Gastrointestinal samples flow through opening 42 and wick into collecting member 18 due to capillary forces or diffusion in the direction of actuator 24. On the surface of collecting member 18 that is opposite actuator 24 is seal 38 that

is forms a water-tight seal when pressed up against opening 42 from the inside of body 12. When gastrointestinal samples reach the distal edge of collecting member 18 and wet actuator 24, actuator 24 expands and pushes collecting member 18 and seal 38 forward against opening 42 in body 12, thereby sealing off collecting member 18 from further fluid communication with the gastrointestinal tract.

5 [0126] In some embodiments, shown in cross section view in Figure 11, actuator 24 is a spring that is held in the compressed state by restraint 34 made from a moisture degradable material. In this manner, once covering element 30 is eliminated in the body, opening 42 is exposed to the fluids of the GI tract. Some of those fluids flow into collecting member 18, and some flow in space 32 around piston 26 to reach restraint 34. As shown in section view in Figure 12, fluid from the GI tract degrades restraint 34,
10 which in turn allows spring actuator 24 to expand, thereby pushing piston 26 axially to seat seal 38 against the surface of body 12, thereby sealing gastrointestinal sample 40 inside collecting member 18. In this manner, actuator 24 is activated only after collecting member 18 has collected gastrointestinal sample 40. In this embodiment, device 10 comprises cap 36 that is removed or punctured in order to access the collected gastrointestinal sample 40 after device 10 is eliminated from the body.

15 [0127] In some embodiments and with reference to Figures 13, 14 and 15, all in perspective cross-section view, gastrointestinal fluids pass through porous collecting member 18 and wet actuator 24. Actuator 24 expands when wet to apply linear pressure on sealing element 38. In Figure 13, device 10 is still contained within capsule 72 which is a sealed capsule whose shell is made from a moisture degradable material such as HPMC and optionally comprises an enteric degradable material acting as
20 covering element 30, for collection of samples in the intestines or colon.

[0128] In some embodiments, covering element 30 directly covers opening 42 and prevents gastrointestinal samples from flowing into collecting member 18. In this embodiment, there is no need for capsule 72 if body 12 is smooth enough to be swallowed directly.

[0129] In both embodiments above, gastrointestinal fluids are not yet in fluid communication with
25 collecting member 18. In Figure 14, covering element 30 has degraded and gastrointestinal samples 40 have started to enter collecting member 18 through opening 42 in body 12 and around seal 38 into collecting member 18. Gas contained in device 10 is vented through vent 66 as gastrointestinal samples 40 enter collecting member 18. In Figure 15, gastrointestinal samples 40 have advanced through collecting member 18 into actuator 24, which is in fluid communication with collecting member 18.
30 Actuator 24 expands when wet, and therefore pushes collecting member 18 towards opening 42, and eventually seal 38 is pressed against the rim of opening 42 thereby sealing collecting member 18 and preventing further sample collection or cross contamination. Actuator 24, when wet, exerts a residual and continuous linear force against seal 38, thereby maintaining the seal throughout the passage of device 10 through the GI tract. In this embodiment the force on seal 38 is in the same direction as the direction of
35 expansion of actuator 24. Examples of materials for collecting member 18 comprise acetate foam and other rigid non-expansive open-cell foams that can transmit linear compressive force from actuator 24 to seal 38. Examples of materials for actuator 24 comprise dehydrated natural or synthetic sponges or

dehydrated superabsorbent materials such as hydrogels, sodium polyacrylate, polyacrylamide or starches at various levels of crosslinking.

[0130] In some embodiments, a wick is placed in opening **42** that helps bring the gastrointestinal samples closer to collecting member **18**, at which point fluid communication is established between collecting member **18** and the fluids in the gastrointestinal tract. The wick is then pushed out of opening **42** when actuator **24** advances collecting member **18**.

[0131] In some embodiments, the degradation of a first moisture degradable restraint allows actuator **24** to move collecting member **18** to a position relative to opening **42** that enables fluid communication between collecting member **18** and the GI tract. Once gastrointestinal samples **40** have been collected in collecting member **18**, the fluid from the collected gastrointestinal samples **40** degrades the second moisture degradable restraint and allows actuator **24** to move collecting member **18** to a position relative to opening **42** that prevents further fluid communication between collecting member **18** and the GI tract. In this manner, a single actuator **24** can move collecting member **18** into the two discrete positions of sample collection and sample isolation using a double trigger moisture degradable restraint mechanism.

[0132] In some embodiments and with reference to Figures 16, 17 and 18, all in perspective cross-section view, gastrointestinal fluids flow through opening **42** and into porous collecting member **18** and wet one or more elements of actuator **24**. Elements of actuator **24** expand when wet to create a plug blocking opening **42**. In Figure 16, opening **42** of body **12** on device **10** are still covered by covering element **30**, and therefore gastrointestinal fluids are not yet in fluid communication with collecting member **18**. In Figure 17, covering elements **30** have degraded and gastrointestinal fluids **40** have entered through opening **42** into collecting member **18** and also wet elements of actuator **24**. Gas contained in device **10** is vented through one or both opening **42** as gastrointestinal samples **40** enter collecting member **18** and displace the gas contained therein. In Figure 18, gastrointestinal samples **40** have caused significant swelling of volumetric expansion of the elements of actuator **24**, thereby forming a dense gel plug that seals opening **42** and prevents further sample collection or cross contamination. In this embodiment, collecting member **18** does not move during the sample collection and capsule sealing process. Examples of materials for collecting member **18** comprise a gas, acetate foam, and cotton. Examples of materials for actuator **24** comprise dehydrated superabsorbent materials such as hydrogels, sodium polyacrylate, polyacrylamide and starches at various levels of crosslinking. The time for expansion or swelling of the particles of actuator **24** is between 1 and 60 minutes to allow for sufficient time for gastrointestinal samples **40** to flow into collecting member **18** before swelling actuator **24** to seal opening **42**. In this embodiment, the fluids of gastrointestinal samples provide the moisture that swells a superabsorbent material into a sealing gel, but only after the gastrointestinal samples have filled collecting member **18**. In this embodiment, the hydrated plug formed by actuator **24** is sufficiently dense to limit bacterial migration or diffusion of biomolecules through the gel to a rate of less than about 0.1 mm per hour.

[0133] In some embodiments, and with reference to Figures 16 through 18, device **10** comprises a vent which is hydrophobic or comprises a one-way valve and does not let gastrointestinal samples inside

body **12**, but rather lets trapped gas vent out as collecting member **18** fills with gastrointestinal fluids. In this embodiment, it is necessary to only have one opening **42** for the entrance of the gastrointestinal samples.

[0134] In some embodiments, and with reference to Figures 16 through 18, device **10** has only a single opening **42** and a covering element **30** into which gastrointestinal samples **40** flow and out of which trapped gases escape. This embodiment relies on the unexpected observation by the inventor that gastrointestinal fluids, especially in the small intestine, have been emulsified by bile acids, which act like a detergent. Therefore, the gastrointestinal samples in the small intestine have extremely very low surface energy and can wick into very small openings, while allowing for trapped gas to be released from that same opening. The bubbles of the released trapped gas have no problem breaking the surface tension of the low surface energy liquid in the small intestines.

[0135] In some embodiments, and with reference to Figures 16 through 18, device **10** has opening **42** adjacent to a gas vent and actuator **24** swells to cover both opening **42** and the gas vent.

[0136] In some embodiments, and with reference to Figures 16 through 18, the material of actuator **24** that expands when wet also functions as collecting member **18**.

[0137] In some embodiments, device **10** comprises a plurality of collecting members **18** separately enclosed with separate opening **42**, seal **38** and/or actuator **24**. Each opening **42** of collecting member **18** is covered by a distinct covering element **30**. Each covering element **30** degrades at a preset pH or dissolution time. In this manner, one device **30** can collect multiple discrete samples of gastrointestinal fluids from different regions of the GI tract without cross talk or cross contamination between the samples.

[0138] In some embodiments, covering element **30** is made from a moisture degradable material that is pH sensitive. Covering element **30** uncovers a first set of openings (e.g., similar to opening **42** and/or **22**) at a pH of 5 or less, leading to a stomach sampling location. Covering element **30** uncovers a second set of openings (e.g., similar to opening **42** and/or **22**) at a pH of 5.5 to 6.5, leading to a proximal small intestine sampling location. Covering element **30** uncovers a third set of opening (e.g., similar to opening **42** and **22**) at a pH of 6.5 to 7.5, leading to a distal small intestine sampling location. Covering element **30** uncovers a fourth set of opening (e.g., similar to opening **42** and **22**) at a pH of 6 to 7 after a set time delay, leading to a colon sampling location. Multiple layers of moisture degradable materials can be designed into covering element **30** so that the final layer degrades at a set time after a series of pH levels is encountered in the layers, leading to anatomically distinct and predictable sampling locations.

[0139] The pH of the human intestinal tract has been extensively studied. Typical results are shown in Table 1 below.

Site	Mean pH (or range)	Standard deviation	Time spent in each region
Stomach	(1.5 - 3.5)	n/a	Up to 3 hours
Duodenum	(5.0 – 6.0)	n/a	Up to 1 hour
Jejunum	6.6	0.5	Up to 1 hour
Ileum	7.5	0.5	Up to 1 hour
Right colon	6.4	0.6	Up to 6 hours
Mid colon	6.6	0.8	Up to 8 hours
Left colon	7.0	0.7	Up to 12 hours

Table 1. pH of the human GI tract. Ref: Gut, 1988, **29**, 1035-1041.

5 **[0140]** An enteric degradable material by its nature degrades above a specific pH level. By way of example, an enteric coating element design to dissolve at pH 7 will likely enable sampling GI fluids at a point between the jejunum and ileum where the pH level transitions from 6.6 to 7.5.

10 **[0141]** The vast majority of the gut bacteria reside in the colon, and more specifically the bacteria are most active in the right colon, otherwise referred to as the cecum or ascending colon. Therefore, a prime target for sample collection is the right colon which is at pH 6.4 +/- 0.6. A major challenge, therefore, is to create a covering element, or set of covering elements, that enable sampling in the right colon. An enteric coating that degrades at pH 6.4 or higher targeting the right colon will degrade in the ileum and sample the fluids in the ileum instead, before reaching the right colon after already having ingested the ileum sample. This is especially true since pH dependent dissolution rates of enteric coatings are significantly higher
15 above their target pH level. An enteric coating that is designed to dissolve at a pH higher than 7.5 may still survive the ileum, in which case it will not dissolve in the right colon where the pH is significantly lower than the ileum. Such a capsule will therefore exit the GI tract with covering 30 intact and without having collected any GI sample.

20 **[0142]** In one embodiment, an external covering element of a device is designed to degrade at a pH level of 6.7 (+/- 0.3) or higher, such that the covering element will dissolve in the distal small intestines and thereby expose an internal covering element. The internal covering element is designed to degrade at a pH of 6.7 (+/- 0.3) or lower. This internal covering element will stay intact in the distal small intestines until device 10 reaches the right colon where the pH drops to below 6.7. Once in the right colon, the internal covering element will dissolve and enable the sample collection process. This embodiment is
25 referred to as “inverse pH” covering elements where the outer covering element dissolves at or above a target pH and the inner covering elements dissolves at or below a target pH. The target pH can be the same or different for the external and internal covering elements, thus targeting any region of the GI tract that has a drop in pH relative to the more proximal adjacent region, which itself is higher than the pH of the stomach.

[0143] In some embodiments, a capsule or device containing an active agent targeting release of that active agent in the right colon comprises an external covering element that degrades at a pH level of 6.7 (+/- 0.3) or higher, such that the covering element will dissolve in the distal small intestines and thereby expose an internal covering element. The internal covering element is designed to degrade at a pH of 6.7 (+/- 0.3) or lower, so that this internal layer will stay intact in the distal small intestines until the capsule reaches the right colon where the pH drops to below 6.7. Once in the right colon, the internal covering element will dissolve or become permeable, thereby enabling the release of the active agent into the right colon.

[0144] By way of example, materials that dissolve above a minimal pH level and are therefore appropriate for the external covering element comprise anionic acrylic polymers with methacrylic acid as a functional group such as Eudragit L, Eudragit S or mixtures thereof (Evonik Darmstadt Germany). By way of example, materials that dissolve below a maximum pH level and are therefore appropriate for the internal covering element comprise cationic polymer with dimethylaminoethyl methacrylate as a functional group such as Eudragit E (Evonik Darmstadt Germany) or modifications thereof. By way of example, in this embodiment wherein sampling device **10** or a capsule containing an active agent intended for colonic delivery or colonic release, the capsule is coated first with an internal covering element of a cationic polymer with dimethylaminoethyl methacrylate as a functional group and then coated with an external covering element of anionic acrylic polymers with methacrylic acid as a functional group.

[0145] In some embodiments, the devices are provided as part of a kit that includes a number of different capsules, each of which is designed to sample a different region of the GI tract. The capsules are swallowed at the same time and collected separately. By way of example, a kit is provided with a stomach targeting, a small intestine targeting and a colon targeting devices. The patient swallows all three capsules and collects them separately in one or adjacent bowel movements. An advantage with the separate device approach is that for a given volume of collected sample, each of the three device can be one third the volume relative a single three-chambered device, thereby minimizing the risk of capsule retention and difficulty of swallowing the device.

[0146] In some embodiments, a set of devices is coated with a moisture or enteric degradable covering element of different thicknesses intended to degrade at different time points to target different regions of the GI tract. Transit time through the GI tract is highly variable among individuals. For example, it could take up to 8 hours after gastric emptying for a capsule to arrive at the right, proximal or ascending colon. The pH of the GI tract is also highly variable among individuals. The proximal or ascending colon has a pH of 6.4 with a standard deviation of 0.6 pH units. To target the gastrointestinal sampling in the proximal or ascending colon based on a specific transit time or specific pH range alone would be difficult without using the dual coating inverse pH technique described above. By way of example, a subject can be provided with three device capsules each coated with a pH sensitive polymer covering element of different thicknesses that all degrade at pH 5.5 or higher, thereby starting to degrade in the small intestine after gastric emptying. The thickness of the covering element can determine whether to covering element degrades over 1, 3 or 6 hours for the three devices, thereby assuring that at least one

device **10** units obtains a sample in the proximal or ascending colon. Example materials for the covering element comprise copolymers derived from esters of acrylic and methacrylic acid dissolvable at a pH of 5.5 or higher at coating density of 5 to 200 milligrams per centimeter squared of body surface area, or preferably 10 to 100 milligrams per centimeter squared of body surface area. A coating density of 5 - 10
5 milligrams per centimeter squared of body surface area will dissolve in around 1 hour whereas a coating density of 100 - 200 milligrams per centimeter squared of body surface area will dissolve in around 8 hours or so, thereby allowing universal targeting of the proximal or ascending colon with 2 or at most 3 devices.

[0147] In another embodiment, individual devices are connected to one another with a string or
10 similar flexible connection element, to ensure that all devices are expelled in the same bowel movement to make collection of multiple devices easier. By way of example, beads of dehydrated sodium polyacrylate are strung along a thread. Each bead is coated with a different time-sensitive or pH-sensitive coating element. The beads get exposed to gastrointestinal samples at different regions of the GI tract depending on when and where the coating element surrounding each bead becomes degraded. Exposed beads imbibe
15 the fluid gastrointestinal samples and swell. Diffusion through the sodium acrylate is sufficiently slow that downstream exposure to microbes or small molecules will not contaminate the sample collected in the inner sections of the sodium acrylate bead. The swollen beads exit the GI tract together as a chain of beads and the samples within each are recovered from the hydrated sodium acrylate gel for further analysis.

[0148] In some embodiments, individual body **12** units are thin-walled hollow structures whose
20 internal volume comprises individual collecting member **18** units. Each body **12** is collapsed and compacted to fit empty inside capsule **72**. After degradation of covering element **30**, the firstly exposed collecting member **18** fills with GI samples. Filling of the first collecting member **18** with GI samples triggers the opening of opening **42** of a second connected body **12**. Filling of the second collecting member **18** with GI samples triggers the opening of opening **42** of a third connected body **12**, etc. In this
25 manner, a set of collapsed yet connected body **12** units can fit compactly inside capsule **72** sample multiple regions of the GI tract, while still being recovered as a linked unit from the stool.

[0149] In some embodiments, illustrated in a cut away side view in Figure 19, individual body **12**
units are linked together in a daisy chain or sausage link format. In this embodiment, each collecting
member **18** contained within each body **12** can collect a discrete sample from the GI tract. This
30 embodiment allows for linking many such body **12** units together, thereby enabling large volumes of samples to be collected despite the maximal diameter of a collecting member of about 2 mm, 3 mm, 4 mm, 5 mm, 6 mm or 7 mm in order to minimize the likelihood of device retention in the GI tract. Furthermore, the thin links between body **12** units allow for full articulation of collecting members in the axial direction relative to one another in order to more easily navigate the small intestine lumen which has
35 sharp curves. The radius of curvature of the small intestine can be as small as 3 cm in a hair pin turn. Therefore, in order to navigate the curvature of the small intestine and minimize risk of retention in the GI tract, each segment of body **12** should be no longer than about 3 cm, and a set of linked body **12** units

should be able to conform to a hair pin turn with a 3 cm radius with a radial force of about 10 grams or less, preferably without kinking.

5 **[0150]** In some embodiments, illustrated in Figure 34, and in order to enable axial articulation into a radius of curvature of the linked collecting members **18** of about 3 cm or less, the length range of segment **74** of collecting member **18** at its maximum diameter is about 1 - 30 mm. The maximum diameter of a narrow section **76** linking segments of the collecting member **18** is about 75% or less of the maximum diameter of the collecting member. The length range of a segment of narrow section **76** collecting member **18** at its smallest diameter is about 1 - 5 mm. Furthermore, the radius of curvature of body **12** in the region of the transition from maximum diameter segment **74** to narrow section **76** is about 1 mm or greater in order to avoid any sharp edges that can damage the delicate intestinal mucosa layer.

10 **[0151]** In some embodiments, there is no element that acts to expands body **12** axially during the unwinding, unfolding or sampling process.

[0152] In some embodiments, the total length of tube-shaped body **12** does not increase in the axial direction during the sample collection process. Rather, the flow of gastrointestinal samples flow into 15 collecting member **18** is due to a radial expansion of the collapsed lumen of tube-shaped and fixed-length body **12**.

[0153] In some embodiments, individual body **12** units are linked by elongated tube or string elements connected to a common point in a manifold, spoke or star configuration.

20 **[0154]** In further embodiments, the length of the elongated tube or string elements that act as spokes or tubes off of a manifold are of different lengths such that the cluster of body **12** units can arranged themselves linearly in single file during the passage through the small intestine.

[0155] In further embodiments, the common connection point of the spoke elements comprises discrete sample openings, seals and/or valves connected to individual collecting members **18** units.

25 **[0156]** As illustrated in Figure 20 in a magnified cut away side view of one collecting member **18**, opening **42** is covered by covering element **30**. Seal **38** acts as a one-way valve to prevent collected samples in collecting member **18** from exposure to cross contamination or leakage during the rest of the transit through the GI tract. In this manner, a negative pressure differential inside collecting member **18** relative to the GI tract, for example by radial expansion of an elastically collapsed or evacuated collecting member **12**, or alternatively capillary pressure alone, drives fluids into collecting member **18**. The 30 collected GI samples cannot flow back out via the one-way valve. Examples of one-way valves comprise flap valve, lay flat tubing, duck bill valve, umbrella valve, ball valve, dome valve, Belleville valve, and cross-slit valve.

[0157] In some embodiments, the rate of sampling is controlled by the balance of two forces. The first force is the force of radial expansion of the compressed tube shaped body **12**, which creates a pressure differential that drives fluid through sampling opening **42** into collecting member **18**. The second 35 opposing force is the resistance to flow through the one way valve in the forward flow direction. One way valves are generally biased closed to prevent flow in the backward direction when there is no pressure differential across the valve. The forward pressure required to open the valve is called the cracking

pressure. The cracking pressure is the first component of the resistance to flow. The second component of the resistance to flow is the size of the opening(s) of the one way valve. The third component of the resistance to flow is the force of the sealing element acting to close the one way valve. All three components act together to create the resistance to forward flow in a one way valve.

5 **[0158]** In some embodiments of device **10**, the cracking pressure required to open the one way valve and generate flow in the forward direction into collecting member **18** is in the range of 0.03 to 15 pounds per square inch, or preferably 0.06 to 5 pounds per square inch. This cracking pressure prevents collected samples from flowing back out of collecting member **18** when there is no pressure differential between the fluids in collecting member **18** and the outside environment. A cracking pressure that is higher than the
10 stated range will not allow for flow of samples into collecting member **18**. A cracking pressure that is lower than the stated range will cause leakage of the collected samples due to peristaltic pressure waves in the GI tract, or by handling of the device outside the body, and then subsequent cross-contamination by any newly ingested samples.

[0159] In some embodiments, the maximal outward radial pressure exerted by a collapsed tube-shaped body **12** is in the range of 10 to 150 grams-force per cm length of body **12**, or preferably 20 to 100
15 grams-force per cm length of body **12**. By way of example, for collecting member **18** with a volume of 0.5 ml, the flow rate of fluid through the one way valve when exposed to a pressure differential created by the outward radial expansion of body **12** and balanced by the counter force of the resistance to flow through the one way valve, as described above, is in the range of 1 microliters of fluid per minute to 500
20 microliters per minute. This flow rate enables device **10** to sample for a time range of 1 minute to 8 hours. Maximal expansive forces above the ranges stated, or valves that enable flow rates above the ranges stated, will cause collecting member **18** to fill in less than 1 minute, and thereby increase the likelihood of sampling gas bubbles present around device **10**. Expansive forces below the ranges stated will not crack open the one-way valve, leading to no sample collection. Therefore a delicate balance of all the factors
25 above is required to properly sample the GI tract over the desired time period. In some embodiments, the passageway between opening **42** and collecting member **18** is normally open. After sufficient sample has been collected, after sufficient sampling time has passed, or after a pH change is detected which indicates movement of device towards a new region of the GI tract, a spring loaded mechanism closes the passageway and seals gastrointestinal samples inside collecting member **18**.

30 **[0160]** In some embodiments, covering element **30** is a collar that keeps opening **42** sealed until the desired region of the GI tract is reached based on hydration time or pH levels of the surrounding fluids that act to degrade covering element **30**.

[0161] In an embodiment illustrated in a sectional view in Figure 40, the passage of gastrointestinal samples through opening **42** into collecting member **18** is gated by seal **38**. Seal **38** in this embodiment is
35 an actively controlled valve. Valve seal **38** is normally closed and actively opened at a predetermined rate to enable collection of gastrointestinal samples. By way of example, valve seal **38** opens for several seconds every hour so that at least eight distinct regions of the GI tract are sampled during an 8 hour sampling window after swallowing device **10**.

[0162] In another embodiment and with reference to Figure 40, valve seal **38** is controlled by pH sensor **78**. During transit of device **10** through the GI tract, when specific pH levels, or the rates of change of pH levels, are sensed by pH sensor **78** in a predicted and pre-programmed sequence corresponding to ascending pH through the small intestine and then descending pH in the right colon, pH sensor **78** triggers the momentary opening of normally-closed valve seal **38** to enable collection of gastrointestinal samples. In this manner, device **10** collects gastrointestinal samples at multiple pH levels corresponding to multiple regions along the GI tract. Example pH levels that can be programmed in device **10** to ensure that all relevant GI regions are targeted for sample collection are described in Tables 1 and 4.

[0163] The maximal volume of body **12**, and hence collecting member **18**, is highly constrained by body **12** needing to fit inside capsule **72** of size 000 or smaller, and that body **12** does not block or become retained in the GI tract when body **12** is in an expanded state outside capsule **72**. Therefore, given that the maximum volume of collecting member **18** is limited, it is important to maximize the amount of informative liquid gastrointestinal samples collected inside collecting member **18**. Collection of gas samples takes up precious volume inside collecting member **18** and is not as informative as liquid samples that contain a much higher density of active organisms and biomolecules compared to gas samples that contain only volatile compounds. In some embodiments and with reference to Figure 40, valve seal **38** is also controlled by flow sensor **80**. In a situation where valve seal **38** is open and liquid gastrointestinal samples are flowing through opening **42** into collecting member **18**, in-line flow sensor **80** senses such a flow and keeps valve seal **38** open until sufficient volume of samples has been collected for that region of the GI tract. However, in a situation where valve seal **38** is open and gas is flowing through opening **42** into collecting member **18**, in-line flow sensor **80** will not sense liquid flow and will therefore send a signal to close valve seal **38** to prevent gas samples from taking up the collection volume inside collecting member **18**. After a sufficient time delay, or when a separate liquid sensor on or near opening **42** senses the presence of liquid samples, valve seal **38** will open again to continue the sampling process. Flow sensor **80** will again confirm the influx of liquid samples into collecting member **18** and will send a signal to keep valve seal **38** open until sufficient volume of liquid gastrointestinal sample has been collected for that region of the GI tract.

[0164] In some embodiments, pH sensor **78** and flow sensor **80** work together to ensure that a pre-specific volume of liquid gastrointestinal samples from a pre-specified pH range has been collected inside collecting member **18**.

[0165] In some embodiments, valve seal **38** controls the flow of trapped gas inside collecting member **18** out of body **12**, thereby allowing gastrointestinal samples to flow into collecting member **18** through a separate, normally open sampling opening.

[0166] In some embodiments, body **12** is elastically collapsed and allowed to re-expand, drawing in gastrointestinal samples in collecting member **18** when valve seal **38** is open.

[0167] In some embodiments, body **12** is a hollow tube 5 mm to 50 cm in length and 1 mm to 8 mm in diameter in which gastrointestinal samples are stored as a linear array inside collecting member **18** which is formed by the lumen of body **12**.

[0168] In some embodiments, after gastrointestinal samples are allowed past opening **42** by valve seal **38**, a manifold and/or additional valves direct gastrointestinal samples into separate collecting members **18**. In this manner, one valve seal **38** can control the sampling of different regions of the GI tract while keep the collected gastrointestinal samples in discrete collecting members to avoid cross
5 contamination.

[0169] In some embodiments, body **12** units are thin-walled hollow structures that are collapsed and stacked empty inside capsule **72** for swallowing in a compact manner. Each collecting member **18** is connected to opening **42** that is sealed with a different moisture-degradable, enteric degradable, time degradable or colonic targeting material covering element **30**. After degradation of the discrete covering
10 elements **30**, each collecting member **18** fills with GI samples corresponding to desired sampling locations in the GI tract as determined by the degradation characteristics of the moisture-degradable, enteric degradable, time degradable or colonic targeting covering element **30**. In this manner, a set of collapsed yet connected body **12** units can fit compactly inside a single capsule **72** and discretely sample multiple regions of the GI tract, while still being recovered as a linked unit from the toilet.

[0170] In some embodiments, device **10** comprises a retrieval tail 2 cm in length or longer that unfurls in the GI tract and facilitates identification and retrieval of device **10** in the toilet.

[0171] In an embodiment shown in Figure 21, device **10** comprises more than one collecting member **18** distributed in a radial arrangement inside body **12**. Each opening **42** is covered with a covering element **30** (not shown) that opens at a different time or a different pH range in the GI tract. In this fashion, device
20 **10** collects a discrete gastrointestinal sample from the GI tract into each collecting member **18**.

[0172] With reference to an embodiment shown in Figure 22 in a perspective view, device **10** has been released from a covering element that covered opening **42** and now device **10** is in the desired position for sampling the GI tract. Collecting member **18** is a cylindrical shaped porous or water soluble element which is in fluid communication with the lumen of the GI tract through opening **42**. After
25 collecting gastrointestinal samples, actuator **24** moves external piston **26** over body **12** to close off opening **42**. At the end of this translation, external piston **26** rests against seal **38** to seal gastrointestinal samples inside collecting member **18**.

[0173] As illustrated in Figure 23 in a sectional perspective view, device **10** is shown before reaching the desired sampling location. Device **10** is within capsule **72**, which is a sealed capsule whose shell is
30 made from a moisture degradable material such as HPMC and optionally comprises an enteric degradable material acting as covering element **30**, for collection of samples in the intestines or colon. Covering element **30** prevents gastrointestinal samples from flowing into collecting member **18**.

[0174] As illustrated in Figure 24, in a sectional perspective view, when device **10** has arrived at the desired sampling location in the GI tract, capsule **72** and covering element **30** have degraded and are no
35 longer present around device **10**. Gastrointestinal samples **40** start flowing into collecting member **18** through opening **42** due to the hydrophilic wicking nature of the porous collecting member **18**, or due to the diffusion of liquid into a water soluble collecting member **18**. Actuator **24** is a bar-bell shaped elastically-stretchable axial member made from a material such as a silicone that is in the maximally-

stretched and maximal-potential energy configuration in the state illustrated in Figure 24. When allowed to partially relax, actuator **24** moves external piston **26** over body **12** to seal opening **42**. Support **68** is a compression member made from moisture degradable material. Such materials comprise HPMC, PVA solid and PVA foam. Support **68** extends from body **12** to external piston **26**. When dry, support **68** prevents stretched actuator **24** from moving to the partially relaxed state and thereby separates body **12** from external piston **26**. As gastrointestinal samples **40** flow into collecting member **18**, the moisture contained therein eventually reaches the center portion of collecting member **18** and starts to degrade the mechanical strength of support **68**.

[0175] As illustrated in Figure 25, in a sectional perspective view, gastrointestinal samples **40** have finished flowing into collecting member **18** and have degraded support **68**. Support **68** has lost structural integrity and is no longer present as a functional component of device **10**. Actuator **24** transitions towards the partially relaxed state and moves external piston **26** over body **12** towards seal **38**. Eventually, external piston **26** covers opening **42** and is sealed against seal **38** with residual potential energy, or tension, present in actuator **24**, thereby isolating gastrointestinal samples **40** inside collecting member **18** and preventing further fluid flow into or out of collecting member **18**. Device **10** is excreted from the body in this state. Once outside of the body, external piston **26** is separated from body **12** to access collecting member **18**, which is full of gastrointestinal samples **40**.

[0176] In some embodiments, a latch mechanism activates and locks once seal **38** is engaged, preventing further separation of seal **38** and exposure of collecting member **18** to the outside environment until gastrointestinal samples are extracted from device **10**.

[0177] In some embodiments, as support **68** is degraded by moisture, piston **26** pushes collecting member **18** into the hollow space of body **12**. Piston **26** and body **12** are eventually pulled together by actuator **24** and sealed via seal **38**, thereby isolating gastrointestinal samples **40** inside collecting member **18**. Residual potential energy, or tension, in actuator **24** keeps piston **26** sealed up against body **12**, thereby preventing further fluid flow into or out of collecting member **18**.

[0178] With reference to an embodiment shown in Figure 26 in a perspective view, device **10** has been released from a covering element that covered opening **42**. Device **10** is configured to sample the fluids in the GI tract. Collecting member **18** is a cylindrical shaped porous or water soluble element which is in fluid communication with the lumen of the GI tract through opening **42**. Device **10** comprises two device bodies **12**, each formed as a hollow piston with seal **38** around the opening end. After collecting a gastrointestinal sample, actuator **24** which is in the form of an external stretched elastic band with stored potential energy, moves the two halves of body **12** inwards towards each other until seals **38** contact, thereby closing off opening **42** and sealing gastrointestinal samples inside collecting member **18**.

[0179] As illustrated in Figure 27 in a sectional perspective view, device **10** is shown before reaching the desired sampling location. Device **10** is within a sealed capsule whose shell is made from a moisture degradable material such as HPMC and optionally comprises an enteric degradable material acting as covering element **30**, for collection of samples in the intestines or colon. Covering element **30** prevents gastrointestinal samples from entering into fluid communication with collecting member **18**.

Magnetic or ferromagnetic attraction element **70** serves to aid recovery of device **10** in the toilet bowl using a hand-held wand comprising a magnetic or ferromagnetic tip. Attraction element **70** also serves as a radiopaque marker to enable visualization of device **10** in the GI tract using non-invasive imaging means.

5 **[0180]** As illustrated in Figure 28, in a sectional perspective view, when device **10** has arrived at the desired sampling location in the GI tract, the capsule and associated covering element **30** has degraded and is no longer present around device **10**. Gastrointestinal samples **40** start flowing into collecting member **18** through opening **42** due to the hydrophilic wicking nature of the porous collecting member **18**. Actuator **24** is an external elastic band that is in the maximally-stretched and maximal-potential energy
10 configuration. When allowed to partially relax, actuator **24** moves body **12** inwards over collecting member **18**, which acts as a guide so that eventually seals **38** meet and seal opening **42**. Support **68** is a compression member made from moisture degradable material that extends from body **12** to one end of collecting member **18**. When dry, support **68** prevents the two halves of body **12** from moving inwards towards one another, thereby forming opening **42**. After gastrointestinal samples **40** have reached the edge
15 of collecting member **18**, the moisture contained therein eventually degrades support **68**.

[0181] As illustrated in Figure 29, in a sectional perspective view, gastrointestinal samples **40** have filled collecting member **18** and have degraded support **68**. Support **68** has lost structural integrity and is no longer present as a functional component of device **10**. Actuator **24** transitions towards the partially relaxed low-potential energy state and has moved the two halves of body **12** inwards until seals **38** contact,
20 thereby closing off opening **42** and sealing gastrointestinal samples **40** inside collecting member **18**. Residual potential energy, or tension, in actuator **24** keeps the two halves of body **12** and seals **38** pressed together, thereby isolating gastrointestinal samples **40** inside collecting member **18** and preventing further fluid flow in or out of collecting member **18**. Device **10** is excreted from the body in this state. Once
25 outside of the body, the two halves of body **12** are separated to access collecting member **18**, which is full of gastrointestinal samples **40**.

[0182] In some embodiments, collecting member **18** is made of a porous material that can resist compression when dry. Such materials comprise sponges made of PVA or natural sponges. For example, as shown in Figures 26-29, collecting member **18**, when dry, also serves as support **68** in resisting the compression force exerted by stretched actuator **24** and prevents the two halves of body **12** and/or piston
30 **26** from moving inwards towards one another, thereby forming opening **42**. The moisture of the gastrointestinal samples **40** soften collecting member **18**. Collecting member **18** loses structural rigidity and the ability to resist compression. Stretched actuator **24** compresses the two halves of body **12** and/or piston **26** to seal against seal **38**, thereby preventing all further fluid communication between collecting member **18** and the gastrointestinal tract.

35 **[0183]** With reference to an embodiment shown in Figure 30, the components of device **10** are shown in perspective view with capsule **72** partially cut away to show the internal components of device **10**. Device **10** comprises body **12** in the form of a coiled hollow tube whose internal lumen forms collecting member **18**. Body **12** opens to the outside of capsule **72** through hole **60**. The opening **42** of hollow tube-

shaped body 12 connects one end of collecting member 18 to the GI tract. A portion of body 12 is coiled inside capsule 72. The other end of collecting member 18 is connected via fluid communication to actuator 24 that is in the form of a hollow bladder made from an elastic material or comprising an elastic member that is normally in its fully expanded state. Between actuator 24 and body 12 is space 48. Seal 44 goes through a hole in body 12. Seal 44 comprises orifice 46 that is normally open, connecting space 48 to the environment outside capsule 72. Device 10 as shown in Figure 30 is in the empty state with expanded hollow actuator 24, empty collecting member 18 and space 48 full of gas at atmospheric pressure.

[0184] As shown in Figure 31, a gas or fluid is pumped into capsule 72 via orifice 46 and occupies space 48. Because of the pressure of the fluid in space 48, hollow bladder-shaped actuator 24 collapses to a minimal volume, thereby storing potential energy in the elastic material or elastic member, while expelling the gas within it through opening 42 of body 12 in the process. Plug 52 is inserted into orifice 46 to create a seal that prevents the fluid inside space 48 from escaping outside body 12. This is the state that device 10 is delivered to a patient before use.

[0185] As shown in Figure 32, when plug 52 is removed from orifice 46, the hollow bladder actuator 24 starts to expand to its relaxed state and shape, thereby forcing the fluid or gas from space 48 out of orifice 46. As hollow bladder actuator 24 expands, a negative pressure is formed in collecting member 18 that draws in gastrointestinal samples 40 through opening 42. The differential volume of hollow bladder 24 between the expanded and compressed states is less than the internal volume of collecting member 18. In this manner, gastrointestinal samples 40 only reside within the spatially-segregated linear-array format of a long hollow collecting member 18, and not in the volume of hollow bladder-shaped actuator 24. The size of orifice 46, the viscosity of the gas or fluid in space 48, and the elasticity of actuator 24 determine the rate of gastrointestinal sampling. The rate of expansion between the fully collapsed state and a fully expanded state of actuator 24 can take 1 minute to 1 hour to sample a specific region of the GI tract, or 1 hour to 8 hours to fully sample the entire GI tract.

[0186] In some embodiments, the fluid introduced into space 48 comprises a gas, water, saline, or oil.

[0187] In some embodiments when oil is introduced into space 48, a moisture degradable covering element blocks orifice 46. Therefore, the sample collection starts only when the covering element blocking orifice 46 is degraded after sufficient exposure to moisture in the GI tract.

[0188] In some embodiments, the fluid introduced into space 48 is a solid at room temperature and a liquid at body temperature.

[0189] In some embodiments, a solid fluid dissolvable element is introduced into space 48 and is exposed to fluids in the GI tract and is eliminated through orifice 46.

[0190] In some embodiments, a narrowing portion of the lumen of hollow tube-shaped body 12 or a constriction therein, acts to limit the rate of sampling of the gastrointestinal samples.

[0191] In some embodiments, body 12 is a hollow tube 0.2 to 2.5 mm in internal diameter, and 0.4 to 3.0 mm in external diameter and 20 to 200 cm in length. The internal hollow lumen of body 12 form collecting member 18. Gastrointestinal samples 40 are introduced into collecting member 18 via opening 42. Gastrointestinal samples 40 form a spatially separated linear array within collecting member 18 in the

order in which they are collected. Movement of gastrointestinal samples **40** into collecting member **18** is due to bulk flow driven by the pressure differential between a radially-collapsed and radially-expanded body **12**. Movement of gastrointestinal samples **40** inside collecting member **18** does not act to chromatographically separate out the components of gastrointestinal samples **40** due to their relative sizes, as would be the case in capillaries used for chromatography which are usually 0.1 mm internal diameter or smaller.

[0192] Diffusion linearly between regions of the linear array of gastrointestinal samples **40** inside tube-shaped body **12** is minimal. In 24 hours at 37 degrees Celsius, the distance of diffusion of small molecules such as glucose, salts, large molecules such as hemoglobin, and even motile bacteria is less than 2 cm. For example, if gastrointestinal samples **40** are collected from the mouth to the rectum at a constant rate within a 60 cm long hollow collecting member **18**, then the spatial resolution of sampling is +/- 2 cm in collecting member **18**, which translates to +/- 1 foot of a 30 foot long GI tract. This represents sufficient resolution to identify areas of interest in the GI tract. If increased resolution is required, collecting member **18** can be longer than 60 cm.

[0193] In some embodiments, portions of the gastrointestinal samples collected in a linear array format inside a long hollow collecting member **18** are separated with bubbles of oil or gas to minimize the diffusion of biomolecules between the portions of gastrointestinal samples.

[0194] In another embodiment, gastrointestinal samples **40** are recovered in a first-in first-out basis by pressurizing collecting member **18** from opening **42** to push gastrointestinal samples **40** out of the end of collecting member **18** farthest from opening **42**. This approach avoids cross contaminating the firstly collected samples in the linear array with the lastly collected samples.

[0195] The GI tract is full of gas in certain regions. At the time of the opening of the vacuum container of prior art devices, if the sampling port is exposed to a gas, then the vacuum force will immediately suck in the gas instead of a fluid sample. Vacuum containers described in the prior art that open at a specific point in time will invariably collect far more gas than fluids, which will lead to non-informative sample collection. In contrast, device **10** disclosed herein collects samples at a much more controllable rate which is relatively independent of the viscosity of the material being sampled. By sampling one region of the GI tract over 1 minute to 1 hour, or sampling the entire GI tract up between the stomach and the ascending colon over a period of 1 hour to 8 hours, it is highly likely that opening **42** will be in fluid communication with fluid gastrointestinal samples for at least some portion of this sampling time window. In some embodiments, for example, as illustrated in figures 30 to 32, the sampling rate is governed mainly by the rate at which fluid or gas leaves orifice **46** and the elasticity of bladder actuator **24**. Therefore, the sampling mode is based on positive displacement. The sampling rate of gastrointestinal samples **40** through opening **42** is the same whether a liquid or gas is being sampled. In the embodiment where body **12** comprises a collapsed lumen forming collecting member **18**, the rate at which body **12** is unfolded, unwound or untwisted determines the rate of sampling of gastrointestinal samples **40**. The rate of unfolding, unwinding and untwisting of body **12** is determined by, among other parameters, the degradation qualities of covering element **30** and the elasticity of body **12**. The body comprising a

collapsed, wound, twisted, or folded tube provides a dual advantage of limiting the sampling rate (thus reducing collection of gas as compared to prior art devices) and providing a much larger volume collecting member 18 within the confined space provided by a swallowable capsule.

[0196] In some embodiments, a porous element or screen with a preselected pore size in the range of 0.1 microns to 200 microns is placed in or in front of opening 42 of body 12 to prevent blockage or to prevent ingestion of any sample elements larger than the pore cut off size. By way of example, a membrane with a pore size of 0.2 microns would not allow any microbial cells to enter collecting member 18, but rather would collect only the fluid surrounding the microbes that may contain other dissolved or suspended biomolecules of interest.

[0197] In some embodiments, body 12 comprises a tube that is coiled, spooled, twisted, folded or compressed tightly enough inside capsule 72 to elastically or reversibly collapse the hollow lumen within body 12 that forms collecting member 18. In order to provide the correct internal collection volume as well as a controllable vacuum force to pull in gastrointestinal samples over a time range of 1 minute to 1 hour to sample one region of the GI tract, or 1 hour to 8 hours to sample most of the GI tract up until the right colon, hollow tube body 12 is preferably 0.2 to 2.5 mm in internal diameter, and 0.4 to 3.0 mm in external diameter and 20 to 200 cm in length. Other dimensions are also possible. For example, the tube shaped body can have an external diameter of about 5.0-7.0 mm. In some embodiments, the tube shaped body comprises an aspect ratio of about 5 or greater. The collapsed collecting member is placed inside capsule 72 in such a manner that capsule 72 prevents the collapsed lumen of body 12 from expanding radially. Capsule 72 or body 12 can be coated or comprise enteric degradable covering element 30. When capsule 72 dissolves or degrades, the collapsed lumen of body 12 starts to transition to its normal relaxed circular cross sectional shape with an expanded hollow space that forms collecting member 18. The hollow space forming collecting member 18 is opened either due to elastic nature of body 12 material or due to capillary forces of liquid collected therein. As body 12 unwinds, untwists, unfolds or expands, liquid and gas gastrointestinal samples are sucked through sampling opening 42 inside collecting member 18 and collected therein.

[0198] In some embodiments, the energy that draws in gastrointestinal samples into collecting member 18 is stored as potential energy in the radial collapse of the lumen of an elastic hollow tube-shaped body 12 with a circular cross section.

[0199] In some embodiments, body 12 with the lumen open or collapsed is wound around a central axis in a spiral fashion, for example, as illustrated in Figures 30 – 32 to maximize the volume of collecting member 18 per the volume of device 10 before swallowing.

[0200] In some embodiments, body 12 with the lumen open or collapsed is wound around a central axis in a spiral fashion, for example, as illustrated in Figures 30 – 32 in multiple overlapping layers to maximize the volume of collecting member 18 per the volume of device 10 before swallowing.

[0201] In some embodiments, body 12 with a radially collapsed lumen is wound around a central axis in a spiral pattern as illustrated, for example, in Figure 35. This configuration is similar to the winding of a collapsed fire hose.

[0202] In some embodiments, body **12** with a radially collapsed lumen is wound around a central axis in a spiral fashion with an axial offset as illustrated, for example, in Figure 36. Body **12** can either not overlap at all, or partially overlaps on itself in this embodiment.

[0203] In some embodiments, body **12** with a radially collapsed lumen is folded one or more times in an accordion or “Z-fold” fashion as illustrated, for example, in Figure 37.

[0204] In some embodiments, body **12** with the lumen open or collapsed is twisted into a helix or coil as illustrated, for example, in Figure 38.

[0205] In some embodiments, body **12** with the lumen open or collapsed is twisted into a helix or coil and then folded one or more times in an accordion or “Z-fold” fashion.

[0206] In some embodiments, body **12** with the lumen open or collapsed is folded one or more times in an accordion or “Z-fold” fashion and then twisted into a helix or coil.

[0207] In some embodiments, body **12** with the lumen open or collapsed is twisted into a super-helix or super-coil. A super-helix or super-coil is a form that has undergone additional twisting in the same direction as or in the opposite direction from the turns in the original helix or coil.

[0208] In some embodiments, tube-shaped body **12** with a radially collapsed lumen forming collecting member **18** is folded one or more time along a central axis in a creased manner as illustrated, for example, in Figure 39.

[0209] In some embodiments, tube-shaped body **12** with a radially collapsed lumen forming collecting member **18** is packed tightly and randomly inside an external body to maximize the volume of collected sample per the volume of device **10** before swallowing.

[0210] It can be preferred that the folding pattern of tube-shaped body **12** not involve invaginating the surface of body **12** in on itself. Invagination of a long tube creates significant friction that does not allow for self-expansion. Folding via invagination works best with a spherical or bulb-shaped body **12**. However, for any given collection volume, a spherical or bulb-shaped body **12** will increase in diameter, and hence present a greater retention risk in the GI tract, relative to a long tube-shaped body **12**.

[0211] The packaging configurations described above can be important for at least three reasons. Firstly, the packaging configurations described above minimize the dead volume and residual gas inside capsule **72**. Any residual gas inside capsule **72** may be sampled by device **10** itself, thereby taking up precious volume in collecting member **18** that should be dedicated to the collection of fluid gastrointestinal samples. Furthermore, residual gas can contain atmospheric oxygen which is detrimental to the viability of the anaerobic microbes being collected in the GI tract. In prior art devices containing expandable bellows for example, the dead volume of device **10** is significant, even before sample collection has occurred. Furthermore, collecting member **18** does not need to vent any trapped gas when body **12** is evacuated of gas via radial collapse prior to packaging in capsule **72**.

[0212] Secondly, the packaging configurations described above maximize the potential volume of collecting member **18** per volume of ingested capsule **72**. Since the volume of collecting member **18** can be effectively zero when properly packaged according to the configurations described above, more than about 50%, preferably more than about 70% percent of the internal volume of capsule **72** can be occupied

with the thin wall tube shaped body **12** and optionally a one way valve mechanism. No volume within capsule **72** is required for a separate actuator or power source as typically found in prior art devices. In these embodiments, elastically radially-collapsed body **12** is both the actuator and the vessel defining the overall volume of collecting member **18**. When packaged inside capsule **72**, collecting member **18** has an internal dead volume of less than about 10-30% (e.g., about 15%), of its maximal volume. In other words, less than about 10-30% of the full volume of collecting member **18** is dead volume that is unavailable for sample collection when body **12** is packaged inside capsule **72**. Collecting member **18** expands to its full volume once outside of capsule **72** with at least about 70-90% of the full volume being occupied by gastrointestinal samples.

5
10 **[0213]** Thirdly, the packaging configurations described above provide many ways to control the rate of expansion of body **12**, and hence the rate of sample collection in the GI tract. It is possible to control the rate of unfolding, uncoiling, untwisting and radial expansion of an elastic tube-shaped body **12** in many ways that are dependent on time or pH. The rate of sampling can therefore be controlled to be in the range of about 1 minute to 8 hours depending on the number of regions of the GI tract to be sampled.

15 **[0214]** In some embodiments, the elasticity of the wound, folded or randomly packed body **12** applies a force that helps break the shell of capsule **72** or covering element **30** in an axial and/or radial direction to initiate sampling when inside the GI tract.

[0215] In some embodiments, multiple covering elements **30** are applied in concentric shells around discrete layers of the coiled or spooled tube-shaped body **12**. Covering element **30** acts to keep a layer of body **12** in the collapsed state. When a layer of covering element **30** degrades due to moisture, time or pH levels, the coiled or spooled body **12** unwinds, thereby expanding the lumen and drawing in gastrointestinal samples into collecting member **18** in a controlled manner. The parameters of degradation of covering elements **30** layers is controlled so that the outer layers of the coiled or spooled body **12** are freed to unwind before the internal layers. In this manner, device **10** samples continuously along the GI tract for a time period of about 1 minute to 1 hour, or about 1 hour to 8 hours. Furthermore, an orderly and gradual unwinding of body **12** prevents the tube from unwinding all at once and kinking or bending on itself.

25
30 **[0216]** In an embodiment illustrated in Figure 33 in partial sectional perspective view, body **12** comprises a continuous or segmented tube that is compressed to have a radially-collapsed lumen forming collecting member **18**. Body **12** is coiled in a manner shown in Figure 35 to form a series of stacked flat disks which are eventually placed as a cylindrical object inside capsule **72**. Each body **12** is coated with a unique moisture-degradable, enteric degradable, time degradable, or colonic targeting covering element **30** that allows each body **12** to unravel and collect GI samples in specific regions of the GI tract.

35 **[0217]** In some embodiments, the pH at which covering elements **30** degrade are ordered from a lower pH at the region of opening **42** of body **12** to a higher pH at the region of the closed end of tube-shaped collecting member **18**. In this manner, the thin-walled tube-shaped collecting member uncoils from opening **42** as device **10** travels from the duodenum, where the pH is 5-6, towards the ileum where the pH

is 7-8. In this manner, device **10** samples continuously along the GI tract over a time range of about 1 hour to 8 hours.

[0218] In some embodiments, capsule **72** is coated with covering elements **30** comprising different moisture-degradable, enteric degradable, time degradable, colonic targeting materials, or different thicknesses of coating, in axially-distinct segments so that specific segments of capsule **72** degrade in a specific order. When a capsule segment degrades, that segment of capsule **72** no longer provides a radial constraining force on the coiled body **12** contained in that segment. Therefore, the coiled body **12** in that segment is allowed to uncoil, the lumen of body **12** expands, and the collecting member **18** collects samples in that region of the GI tract.

[0219] In some embodiments, body **12** can comprise an elastic thin walled tube with one closed end and one open end that is compressed to have a collapsed lumen and is coiled to form a stack of three flat disks similar to three layers of a coiled firehose as illustrated in Figure 35. The closed end of body **12** is in the radial center of the first disk and the open end of body **12** is at the outer circumference of the third disk. The open end of body **12** is opening **42**. The three disks are stacked one on top of the other to form a cylindrical object which is introduced into water-degradable capsule **72**. The first round cap portion of capsule **72** located adjacent to the opening **42** is uncoated and will dissolve in the stomach. The middle portion of capsule **72** is coated with a first enteric covering element **30** that targets the proximal small intestines, and the second cap portion of capsule **72** adjacent to the closed end of body **12** is coated with a second enteric covering element that targets the distal small intestines. After being swallowed, the first cap portion of capsule **72** dissolves in the stomach which allows the first disk to uncoil, which in turn expands the lumen of the first disk of body **12** to draw in GI samples from the stomach. In the proximal small intestines, the middle portion of capsule **72** dissolves which allows the second disk of body **12** to uncoil and sample the proximal small intestine contents. In the distal small intestines, the second cap portion of capsule **72** dissolves which allows the third disk of body **12** to uncoil and sample the distal small intestine contents. A linear array of samples from the stomach, proximal small intestines and distal small intestines now rests inside collecting member **18** which formed by the inner lumen of body **12**.

[0220] Importantly, in the linear array embodiments, the first samples entering collecting member **18** do not experience any contamination by the walls of the lumen of body **12**. Subsequent samples from more distal portions of the GI tract that enter collecting member **18** may be exposed to trace amounts of the previous samples adhering to the walls of the lumen of body **12**. However, this cross contamination also recapitulates the natural cross contamination in the GI tract in which most biomolecules in the proximal GI tract eventually pass through and are present in the more distal GI tract on the way out of the body. More disks and more enteric coating segments can be used to sample the GI tract at a finer resolution. The tube shaped body **12** can also be a segmented tube with each segment representing a discrete collecting member **18** to further prevent cross contamination between the collected samples.

[0221] In some embodiments, one end of a hollow tube-shaped body **12** is closed so that liquid and gas gastrointestinal samples can enter into only a single opening **42** of collecting member **18** as it unwinds, untwists, unfolds or expands.

[0222] In some embodiments, sampling opening **42** of the hollow tube-shaped body **12** with a collapsed lumen is on the outside of the winding or folding configurations shown in Figures 35 to 39. In these embodiments, device **10** starts to sample as soon as body **12** starts to unwind, untwist, unfold or expands, which allows for sampling in the more proximal regions of the GI tract.

5 [0223] In some embodiments, sampling opening **42** of the hollow tube-shaped body **12** with a collapsed lumen is on the inside of the winding or folding configurations shown in Figures 35 to 39. In these embodiments, device **10** starts to sample only after the entirety of body **12** has unwound, untwisted, unfolded or expanded. This configuration allows for peristalsis to have an object of sufficient size to act on in order to carry device **10** to the distal regions of the GI tract before sampling starts. In this
10 embodiment, device **10** is configured for sampling of the more distal regions of the GI tract.

[0224] In some embodiments that target the right ascending colon, the coiled, twisted, folded or compressed hollow body **12** is covered with a split capsule **72**. When in the small intestines, radially directed squeeze pressure of the small intestine wall on device **10** prevents dislodging of split capsule **72** and the subsequent expansion of body **12**. When device **10** enters into the right colon, where the internal
15 diameter of the lumen is around 3 inches, as compared to the 1 inch diameter of the small intestine lumen, the split capsule **72** is no longer squeezed together and falls apart into separate elements or opens like a clamshell. Without the restraining force of the split capsule **72**, hollow body **12** expands, and thereby device **10** starts to sample the gastrointestinal contents of the right colon.

[0225] In some embodiments that target the right ascending colon, opening **42** is sealed by a sealing
20 element that can be dislodged in the outward radial direction, as long as no inward radial pressure is applied to the sealing element. Capsule **72** comprising covering element **30**, as well as inwardly directed radial squeeze pressure of the small intestines on device **10** prevents dislodging of this sealing element until device **10** enters into the right ascending colon, where the internal diameter of the lumen is around 3 inches as compared to the 1 inch diameter of the small intestine lumen. Without the sealing element in
25 place, GI samples from the right colon flow through opening **42** into collecting element **18**.

[0226] In some embodiments that target the right colon, the coiled, folded, kinked or compressed hollow body **12** cannot unwind, unfold or expand when exposed to the inward directed radial squeeze pressure of the small intestines. When device **10** enters into the right ascending colon, where the internal diameter of the lumen is around 3 inches as compared to the 1 inch diameter of the small intestine lumen,
30 body **12** unwinds, unfolds, unkinks or expands, which opens sampling opening **42** and thereby device **10** starts to sample the contents of the right ascending colon.

[0227] In some embodiments that target the right colon, sampling is triggered by detecting the presence of large pockets of gas around device **10**. By way of example, an ultrasound transducer can detect whether device **10** is surrounded by gas, liquid, or intestinal tissue, and thereby trigger sample
35 collection only when gas is detected for a preset period of time. Large volumes of gas, mainly hydrogen, carbon dioxide and methane, are present in the colon. This is in contrast to the small intestines which are generally full of fluid with the exception of small bubbles.

[0228] In some embodiments that target the right colon, sampling is triggered by detecting the reduction of heat flow from device **10** out to the GI tract due to large pockets of gas surrounding device **10**. By way of example, a resistive heater with current feedback can detect if the heater is surrounded by gas or liquid, since heat flow is higher through liquid than through a gas.

5 [0229] In some embodiments, opening **42** is sealed or opened based on the expansion or contraction of a pH-sensitive hydrogel. The target pH transition point of the hydrogel is used to target a specific region of the GI tract for sampling based on the expected pH level of that region of the GI tract.

[0230] In some embodiments, the collected GI samples inside collecting member **18** comprise a volume of a gas sample adjacent to a volume of a liquid samples. The gas sample is collected separately
10 from the liquid samples for further analysis.

[0231] In some embodiments, actuator **24** is an actuator that creates negative pressure at the opening **42** of collecting member **18**. Example actuators comprise a reciprocating vacuum pump, centrifugal pump, electrical actuated actuators, solenoids, electromagnetic coils that attract or repel, electroactive polymers, piezoelectric element, and the like. Modes of pumping comprise peristaltic, pulsatile and
15 displacement with our without one way valves.

[0232] In some embodiments, actuator **24** creates a slight positive pressure at opening **42** of collecting member **18** to flush or purge out any materials or particles that may be blocking opening **42**. Actuator **24** then creates a longer or higher negative pressure at opening **42** of collecting member **18** to collect more gastrointestinal samples than were expelled during the flush or purge step.

20 [0233] In some embodiments, a hydrophilic or superhydrophilic inner surface and small internal diameter of the of hollow tube-shaped body **12** will make gastrointestinal samples **40** flow into collecting member **18** by capillary forces alone, eliminating the need for actuator **24**. Example hydrophilic or superhydrophilic inner surfaces comprise introducing an open cell gel or foam into the lumen of body **12**, acid etching, or coating the lumen of body **12** with hydrophilic or superhydrophilic molecules such as a
25 hydrogel, and the like.

[0234] In some embodiments, the inner surface of a hollow body **12** is hydrophobic and will still enable collection of GI samples, given that the surface tension of GI samples is very low, mainly due to the bile acids contained therein acting as a detergent. Therefore, GI samples will readily flow into a body **12** made from a hydrophobic material. The advantage of a hydrophobic surface is lower adherence of
30 gastrointestinal samples to the wall of body **12** and therefore lower cross contamination in a linear array format of collecting member **18**.

[0235] In some embodiments, the inner volume of hollow tube-shaped body **12** comprises an open cell structure that increases the capillary wicking ability of collecting member **18**.

[0236] In some embodiments, the wall of hollow tube-shaped body **12** comprises a material that
35 allows the gas trapped in collecting member **18** to escape through the wall into the gaseous or liquid environment surrounding device **10**. The gastrointestinal samples that are transported via capillary forces into the lumen of hollow tube-shaped body **12** displace the trapped gas out of collecting member **18** via the lumen wall at a known rate. By way of example, hollow body **12** is made from a material comprising

cellulose, or cellulose ester, polysulfone, polytetrafluoroethylene (PTFE), polyvinylidene fluoride (PVDF), polyethersulfone (PES), etched polycarbonate, and collagen. These materials are gas permeable but not fluid permeable.

5 [0237] In some embodiments where capillary forces drive gastrointestinal samples 40 into collecting member 18, a gas permeable but water repelling venting opening on body 12 allows the gas inside collecting member 18 that is being displaced by the flow of gastrointestinal samples 40 into opening 42 to escape outside of device 10 via bulk flow or diffusion. Examples of such venting openings comprise hydrophobic materials such as polyvinylidene fluoride, polytetrafluoroethylene, and polyethylene in tube, frit, spun or porous forms. In this embodiment, gas in the GI tract will not be sampled as capillary forces
10 will act to only drive fluid gastrointestinal samples 40 into collecting member 18. The rate of sampling in this embodiment is controlled via a combination of the diameter and hydrophilicity of the internal surface of tube-shaped collecting member 18, and the gas permeability and surface area of the venting opening. When the venting opening is exposed to the gases of the GI tract and not in contact with gastrointestinal fluids, and at the same time opening 42 which extends beyond body 12 is resting on a mucosal surface of
15 the lumen, then mucosal gastrointestinal samples will be efficiently collected in collecting member 18 due to capillary forces since the trapped gas in collecting member 18 will easily exit the venting opening. In this manner, mucosal gastrointestinal samples are preferentially collected over bulk gastrointestinal fluid, thereby increasing the concentration of microbes sampled since microbes reside mainly on the mucosal layers of the GI tract and exist only in dilute form in bulk gastrointestinal fluids.

20 [0238] In some embodiments, collecting member 18 and/or the inside volume of body 12 is full of a gas that diffuses into water more readily than air. Example gases comprise helium hydrogen, and carbon dioxide.

[0239] In some embodiments, hollow body 12 is made from lay flat tubing with essentially no gas contained within its lumen when collapsed, flat and empty. When gastrointestinal samples enter opening
25 42, capillary forces drive the liquid gastrointestinal samples into the lumen of body 12 which forms collecting member 18. The lumen of collecting member 18 expands from a collapsed state to an open state in the areas filled with gastrointestinal fluids. The non-sampling opening of collecting member 18 does not need to vent any trapped gas in this embodiment.

[0240] In some embodiments, the opening 42 of body 12 is flush with device capsule 72.

30 [0241] In some embodiments, opening 42 of hollow tube-shaped body 12 extends at least 5 mm beyond capsule 72, causing opening 42 to contact the GI tract mucosal layer at almost all times, thereby maximizing the chance of a gastrointestinal sample being collected. In this embodiment, the section of body 12 that extends beyond capsule 72 does not remain horizontal under its own weight. Therefore, gravity will force the section of body 12 that extends beyond capsule 72 to fall down against the surface
35 of the GI lumen.

[0242] In some embodiments, opening 42 that extends beyond capsule 72 is weighted to ensure that opening 42 rests on the GI tract lumen surface.

[0243] In some embodiments, device **10** is formed using 3D printing techniques that create a coiled or tortuous hollow capillary path within the internal volume of device **10** directly. Example 3D printing techniques comprise photo-polymerization, sintering or additive manufacturing.

[0244] In some embodiments, device **10** is formed using stacked sections where a collecting member **18** is formed as a depression into each layer. The layers are stacked and bonded to each other, with the backside of each layer sealing the collecting member **18** of the adjacent layer. The collecting members **18** of each layer are in fluid communication with each other via a through hole between the layers.

[0245] In some embodiments, collecting member **18** or portions thereof are formed by baffles or other thin features that are spaced sufficiently close to create surface tension to draw in the liquid gastrointestinal samples. Spacing of the baffles or thin features are in the range of 0.2 mm to 4 mm, which forces a radius of curvature of the meniscus of the gastrointestinal fluids to be in the range of 0.1 mm to 2 mm, thereby causing significant capillary action due to surface tension to draw in the gastrointestinal sample into collecting member **18**.

[0246] In some embodiments, multiple opening **42** emerge from body **12**. The multiple opening **42** are merged into a single collecting member **18**. In this manner, the likelihood of one opening **42** being in contact with the lumen of the GI tract is maximized.

[0247] In some embodiments, more than one device **10** unit is provided as a kit for the patient to swallow at the same time. Each device **10** is designed to expose opening **42** at a different time point or location in the GI tract. Device **10** units are collected in the same bowel movements, or in subsequent bowel movements, for further analysis. It is safer to swallow a plurality of smaller device **10** units than one large device **10** that samples numerous regions of the GI tract.

[0248] A certain volume of gastrointestinal samples **40** is collected by device **10** for further analysis, which is defined as the collected volume. Device **10**, packaged in capsule **72**, itself has a certain external volume before it is swallowed. The ratio of the collected volume to the volume of capsule **72** is defined as the "collection volume percentage". The higher the volume of collected sample, the more analyses can be performed on the gastrointestinal samples, and/or at a higher sensitivity. Furthermore, the higher the volume of the collected sample, the easier device **10** is to identify and retrieve from the stool. At the same time, the volume of capsule **72** should be as low as possible to minimize the difficulty of swallowing the device. Device **10** itself should have as small of a diameter as possible to minimize the risk of retention of device **10** in the GI tract. For example, the retention rate of capsule endoscopy devices (Medtronic Capsule Endoscopy System, Medtronic Inc. Minneapolis, MN, USA) which are approximately 11.6 mm in diameter and contain 3 milliliters of volume, is 1.4%. In most of these cases, the retained capsule endoscope needs to be removed from the GI tract surgically. A retention rate of 1.4% is unacceptably high for routine collection of gastrointestinal samples performed at a population-scale. To minimize or eliminate retention in the GI tract, the outside diameter of device **10** should be about 9 mm or less, preferably about 7 mm or less, and more preferably about 5 mm or less. In order to minimize discomfort while swallowing, capsule **72** volume should be about 1.37 ml or less, corresponding to a size 000 capsule which is the largest degradable capsule shell commercially available. Device **10** should still allow

a collected sample volume of about 0.3 ml or more to enable sufficient sensitivity and breadth of analyses desired, leading to a minimal preferable collection volume percentage of around 0.3 ml /1.37 ml, or 22%. Table 2 below shows the volumes and diameters of common and standardized capsule sizes referred to in this patent application. Note that commercially available capsules are not made larger than size 000, which is the upper limit considered acceptable for swallowing. Any extraneous mechanisms, power sources or structure in device **10** acts to decrease the collection volume. Therefore, the configuration of device **10** disclosed herein maximizes the volume of collecting member **18** and minimizes the size and volume of all the other components of device **10** required to make it functional. The required functions of device **10** can comprise:

1. Provide a smooth outer surface while swallowing,
2. Have a maximum diameter of 9 mm, 7 mm or 5 mm or less to minimize risk of device retention,
3. Collect fluid samples at the desired region of the GI tract over a time range of 1 minute to 1 hour, or of the entire GI tract over a time range of 1 hour to 8 hours.
4. Protect the collected fluid sample from leakage, contamination or oxygen exposure.

[0249] In some embodiments, the size of capsule **72** containing device **10** is 000 or smaller and the collection volume percentage is about 25% or greater. In another embodiment, the size of capsule **72** containing device **10** is 000 or smaller and the collection volume percentage is about 50% or greater. In another embodiment, the size of capsule **72** containing device **10** is 000 or smaller and the collection volume percentage is about 100% or greater.

Capsule size	000	00	0	1	2
Volume (ml)	1.37	0.90	0.68	0.48	0.36
Diameter (mm)	9.91	8.56	7.64	6.96	6.39

Table 2. Volumes and diameters of standard capsule sizes.

[0250] In some embodiments, device **10** comprises a tube shaped body **12** that is about 9 mm in diameter or smaller, about 7 mm in diameter or smaller, about 5 mm in diameter or smaller, or about 3 mm in diameter or smaller. In order to obtain sufficient volume of sample, tube shaped body **12** when full of gastrointestinal sample is about 5 mm long or longer, about 1 cm long or longer, about 20 cm long or longer, or about 50 cm long or longer. By way of example, a 50 cm long tube with an outer diameter of 2 mm and in inner diameter of 1.5 mm has an internal volume of 0.89 ml. When the lumen of such a tube is collapsed and coiled tightly, the tube can fit inside a size 0 capsule with an internal volume of 0.68 ml. In other words, collecting member **18** can contain more volume of collected sample than the internal volume of capsule **72** containing body **12**. In this example, body **12** even in the fully expanded state has a much smaller diameter than capsule **72**. Body **12** also does not become longer than its original length before

being compacted to fit inside capsule **72**. Rather, body **12** is radially-collapsed and packaged in a volume-efficient manner before being inserted into capsule **72**. Since the size 0 capsule **72** is dissolvable, capsule **72** does not present a risk of retention. However, to prevent retention of a non-dissolvable body **12** in a narrowed or constricted GI tract, which is the case in many patients suffering from Crohn's disease or ulcerative colitis, a body **12** that is about 2 mm outer diameter, or even about 7 mm outer diameter is much safer alternative than a body **12** that is 9 mm or larger in diameter.

[0251] In some embodiments and by way of example, device **10** in the form of a thin-walled segmented tube-shaped body **12** 50 mm in length and 5 mm in diameter as illustrated in Figure 34. Seal **38** acts as a one-way valve to prevent collected samples in collecting member **18** from exposure to cross contamination or leakage during the rest of the transit through the GI tract. Collecting member **18** can contain a sample volume of 1.0 ml, yet the packaged device **10**, when compressed by folding, twisting, winding or random packing, fits inside a size 2 capsule which has a volume of 0.36 ml. Therefore, the collection volume percentage of this embodiment is 277%.

[0252] In some embodiments, the lumen of collecting member **18** is collapsed to form a potential space to eliminate as much dead volume and residual gas as possible. Dead volume in the packaged body **12**, or within the lumen of collecting member **18**, takes up space that could otherwise be used for sample collection. In addition, if the dead volume is air, then the oxygen in the air will act to kill off many of the anaerobic bacterial species collected.

[0253] In some embodiments, the dead volume, defined as the volume of residual gas inside collecting member **18** prior to being swallowed, relative to the maximal volume of collecting member **18** when full of samples is less than about 50%, preferably less than about 30% and more preferably less than about 10 %.

[0254] In some embodiments that are designed to preserved the viability of the anaerobic microbes collected by device **10**, the inside volume of body **12** and/or collecting member **18** is at a pressure lower than atmospheric pressure to minimize the amount of oxygen inside collecting member **18**.

[0255] In some embodiments that are designed to preserved the viability of the anaerobic microbes collected by device **10**, the inside volume of body **12** and/or collecting member **18** is flushed with a gas that does not contain oxygen prior to packaging device **10** inside capsule **72**. Example gases comprise carbon dioxide, nitrogen and argon. Seal **38** or one way valve **24** limit the exposure of the collected sample inside collecting members **18** to oxygen even when device **10** has exited the body.

[0256] The aspect ratio of device **10** is defined as the fully expanded length divided by the fully expanded diameter of device **10**. To achieve an acceptably low retention risk, the maximum diameter of device **10** is about 9 mm or smaller, preferably about 7 mm or smaller and more preferably about 5 mm or smaller. The minimum collected volume to enable the desired number of analyses on the collected gastrointestinal samples is about 0.1 ml or more, preferably about 0.3 ml or more and more preferably about 0.6 ml or more. Therefore, the aspect ratio of device **10** that satisfies both of these constraints is preferably 8 or greater. The aspect ratio of standard dissolvable capsules is around 2.75. Therefore device **10** needs to transform into an aspect ratio much higher than the aspect ratio of the outer capsule **72**

containing device **10**. However, long slender object have difficulty navigating through the tortuous anatomy of the small intestines. Therefore, device **10** with an aspect ratio above 5 should be segmented or thin enough to enable device **10** to bend axially to match the curvature of the small intestine lumen, which has hairpin turns of approximately 3 cm radius of curvature.

5 **[0257]** Furthermore, to maximize the volume of sample collected, it is preferable that the volume of all structures of device **10** be about 40% or less, preferably about 30% or less and more preferably about 20% or less of the volume of the collected gastrointestinal samples. Assuming that 1 ml is collected by device **10**, this constraint leaves only about 0.3 ml, or preferably about 0.2 ml, or more preferably only about 0.1 ml of volume for body **12** and all associated structure, power sources, seals, valves and
10 actuators. In the example of device **10** illustrated in Figure 34, the collected volume is 1.0 ml and the volume of all structural elements is 0.2 ml, which is a 20% ratio for the volume of device **10** relative to the volume of the gastrointestinal sample collected. Prior art devices with motors, batteries, computational devices and other bulky elements constitute significant “overhead” and leave little space relative to the overall volume of the device for sample collection. Prior art devices, therefore, have a ratio
15 of structural volume to collected volume far in excess of 20%.

[0258] In some embodiments, to minimize the chance of retention in the GI tract, the collecting member has a maximal cross sectional area of about 3 square mm or less, about 10 square mm or less, or about 20 square mm or less, while at the same time collecting at least 0.3 ml of gastrointestinal fluid sample.

20 **[0259]** In some embodiments, device **10** comprises multiple collecting members **18**, each protected from exposure to GI fluids by a covering element that degrades at a set time, pH or bacterial level in the GI tract. By way of example, each opening **42** in device **10** that comprises seven collecting members **18** is covered in the manner depicted in Table 3 below.

Collecting member	Covering element	Region sampled
1	None	Mouth and esophagus during swallowing
2	Degrades in 5 minutes after exposure to moisture	Stomach
3	Degradable immediately at pH greater than 5	Proximal small intestines
4	Degradable 1 hour after exposure to pH greater than 5	Distal small intestines
5	Degradable once exposed to enteric bacteria	Ascending colon
6	Degradable 3 hours after exposure to colonic bacteria	Transverse colon
7	Degradable 7 hours after exposure to colonic bacteria	Descending colon and stool

Table 3: Design of covering elements **30** that enable sampling of various regions of the GI tract.

[0260] In alternative embodiments, six covered opening **42** are shielded from the GI tract by six covering elements **30** that are individually designed to degrade after about 0.1, 1, 2, 3, 5, and 8 hours of exposure to GI tract fluids in a pH independent manner. This configuration would enable gastrointestinal samples to be collected in the regions of the GI tract corresponding to 0.1, 1, 2, 3, 5, and 8 hours after swallowing, which is sufficient to cover the stomach, small intestines and colon regions for most individuals.

[0261] In some embodiments, the position of the GI tract sampled by device **10** is imputed or confirmed a posteriori at the time of sample analysis using one or more position identification parameters. Example position identification parameters are listed in Table 4. Position identification parameters of a collected gastrointestinal sample comprise parameters such as pH, color, bacterial count, bacterial identity, hormones, dissolved gases, enzymatic activity, biochemical markers, capsule movement patterns, and intraluminal pressure. By way of example, if the collected gastrointestinal sample is clear or pink, has a pH of less than 3, a total bacterial count of less than 1,000 bacteria per gram of fluid collected and high levels of gastrin, then it can be deduced that the sample was collected from the stomach. By way

of example, if the capsule includes a motion detector and recorded back and forth movement, than that sample was collected from the duodenum where chyme is moved back and forth to mix with digestive juices. By way of example, if the collected gastrointestinal sample is green or brown in color, then it was likely collected in the proximal and ascending colon. In this manner, samples can be collected at various time points and in an a posteriori manner mapped to the most probable location of the GI tract where that sample was taken.

[0262] In some embodiments, one position identification parameter of the collected gastrointestinal sample is used to impute the sampling location in the GI tract.

[0263] In some embodiments, a combination of two or more position identification parameters of the collected gastrointestinal sample is used to impute the sampling location in the GI tract.

[0264] In some embodiments, a combination of three or more position identification parameters of the collected gastrointestinal sample is used to impute the sampling location in the GI tract.

[0265] In some embodiments, a combination of four or more position identification parameters of the collected gastrointestinal sample is used to impute the sampling location in the GI tract.

[0266] In some embodiments, the imputed sampling location in the GI tract is expressed as a probability with a confidence interval.

[0267] In some embodiments, device **10** has a detector to detect one or more of the position identification parameters listed in Table 4 in real time when in the GI tract.

[0268] In some embodiments, device **10** takes action based on the detection of one or more of the position identification parameters listed in Table 4 in real time when in the GI tract..

Imputed sampling location in the GI tract	pH	Color	Total bacteria per gram of fluid sample	Aerobes and facultative anaerobes per gram of fluid sample	Anaerobes per gram of fluid sample	Dissolved or free gas content	Other markers
Stomach	1.5-3.5	Clear or pink	0-10 ³	0-10 ³	0	Oxygen	gastrin
Jejunum	6.1-7.1	Yellow	0-10 ⁴	0-10 ⁴	0		cholecystokinin, secretin, gastric inhibitory polypeptide, motilin

Ileum	7.0-8.0	Yellow to light green	10 ⁴ -10 ⁸	10 ⁴ -10 ⁵	10 ³ -10 ⁸		cholecystokinin, secretin
Proximal colon	5.8-7.0	Dark green to light brown	10 ¹⁰ -10 ¹²	10 ² -10 ⁹	10 ¹⁰ -10 ¹²	High levels of carbon dioxide and hydrogen. Presence of pockets of free gas (not just bubbles)	carbohydrate enzymatic activity
Distal colon	6.3-7.7	Light brown to dark brown	10 ¹⁰ -10 ¹²	10 ² -10 ⁹	10 ¹⁰ -10 ¹²	Medium levels of carbon dioxide and hydrogen	carbohydrate enzymatic activity

Table 4. Examples of position identification parameters that can be used a posteriori to impute the probabilistic location of a collected gastrointestinal sample. Ref on gas content: Nature Electronics, Vol 1, January 2018, 79–87.

- 5 **[0269]** In some embodiments, device **10** contains within it a camera and power source, together with on-board image storage capabilities or wireless transmission capabilities to an external image storage device.
- [0270]** In some embodiments, device **10** is connected via a short tether to a separate imaging capsule (for example the Medtronic Capsule Endoscopy System, Medtronic Inc. Minneapolis, MN, USA) and the
10 imaging capsule and device **10** are swallowed together and move together through the GI tract.
- [0271]** The visual images taken by the camera are time stamped. The start time and rate of sampling of device **10** is also known. Therefore, in both embodiments with the camera above, sampling locations in the GI tract are correlated to visual images taken by the camera by aligning the data from both onto a common timeline. Alternatively, the imaging capsule images the act of sampling by device **10**, allowing
15 direct visualization and confirmation of the GI region being sampled. Areas of visual interest can be further studied by analyzing the collected samples from that location. Likewise, interesting gastrointestinal samples can be further studied by analyzing the visual images taken from that location.
- [0272]** In some embodiments, the imaging system on board the sample collection device **10**, or the imaging system in the dedicated imaging capsule tethered to device **10**, communicates with device **10** and
20 triggers a sample collection event when certain features are noted in the image. Examples of such features comprise bleeding mucosa, signs of inflammation, anatomical landmarks, and the like. In this manner, gastrointestinal samples are collected in specific regions of interest in the GI tract.

[0273] In some embodiments, the color of the gastrointestinal sample as collected by device **10** is used to identify the region of the GI tract that the sample was collected from. Using a color analysis obtained via capsule endoscopy (Medtronic Capsule Endoscopy System, Medtronic Inc. Minneapolis, MN, USA), the present inventor discovered that clear samples are associated with the stomach, yellow tinted samples are associated with the bile acids present in the proximal portion of the small intestine, light green tinted samples are associated with the distal small intestines, dark green or light brown tinted samples are associated with the proximal or ascending colon, and dark brown tinted samples are associated with the fecal matter present in the distal colon. In the traditional use of capsule endoscopy, the patient is advised not to eat or drink, and in some cases prepare the colon for endoscopy before the endoscopy procedure, such that the lumen of the GU tract is empty of all ingested matter. In contrast, the present inventor created capsule endoscopy images take before, during and after ingestion of food, thereby discovering the nature and color of the ingested food along with the associated microbiota, as well as the dynamics of the GI tract at all phases of digestion and at all regions of the GI tract. By way of example, it has not been previously known that the content of the ascending colon, together with its associated microbiota, is in the range of light green to light brown in color until discovered in the manner above.

[0274] The colors visible at the outer surface of device **10** are generally red, pink or yellow when device **10** is traversing the GI tract that is devoid of digested food. In contrast, there is almost always digesting food and high levels of microbiota present in the distal small intestines and the proximal or ascending colon just distal to the ileocecal valve, where digestion processes occur over the course of many hours after the ingestion of a meal. The inventor has discovered that the colors visible at the outer surface of device **10** in the distal small intestines and proximal or ascending color are generally green and brown in color. In another embodiment, device **10** comprises a light source such as a light emitting diode that emits white light and one or more photodetectors that have in front of them filters selective for red and green wavelengths.

[0275] In some embodiments, device **10** comprises both a green and red light source and one or more photodetectors that separately measure the intensity of the reflected red or green light source.

[0276] In some embodiments, a portion of body **12** is optically clear and indented or invaginated so that the liquid contents of the GI tract collect therein. The color of this collected fluid is measured by any of the reflectance techniques described above. Without the indented or invaginated window, the tissue of the GI tract, which is pink in color, presses up against body **12**, and the color of the luminal contents of the GI tract is not apparent or measurable. The indented or invaginated window is sufficiently shallow to allow for continuous exchange of the surrounding fluids as the capsule moves through the GI tract without enabling the tissue of the GI tract to touch the deepest portion of the indented or invaginated window.

[0277] In some embodiments, the indented or invaginated window as described above is illuminated from one side of the window and the transmitted light is measured from the other side. In this manner, the light crosses a defined length of fluid from the GI tract before being measured by a sensor.

[0278] The location of device **10** in the GI tract can be deduced by the absolute intensity and/or the ratio of the red and green reflected light as measured at the surface of the device. Sampling events can then be initiated based on the color of the medium surrounding the device. By way of example, when the absolute levels of green and red reflected light are both low, then device **10** is most likely in the stomach where there is not always intimate contact between the stomach wall and the device. When the intensity of the red reflected light is slightly higher than the green reflected light, device **10** is most likely in the small intestines. When sufficient green tint is detected relative to the red tint of reflected light, device **10** is most likely in the green or brown-colored luminal contents of the proximal or ascending colon. A gastrointestinal sample collection process can be initiated by device **10** at any one or combination of these locations based on preset thresholds, or based on a pattern of ratios or absolute intensities of green and red color reflections as measured by the device.

[0279] In some embodiments, device **10** comprises a pressure sensor that records the pressure exerted by the GI tract on device **10** in a time stamped manner. A record of pressure is used to identify anatomical landmark areas of high radial or squeeze pressure on device **10**, comprising passage of device **10** through the upper esophagus sphincter, the lower esophageal sphincter, the pyloric sphincter, the ileocecal valve, and the anus. A pattern of these pressure events is used to associate the collected gastrointestinal samples to specific regions of the GI tract. For example, in the subsequent hour or so after swallowing the device, a high radial pressure event indicates passage of device **10** through the pyloric sphincter between the stomach and the duodenum. A subsequent high radial pressure followed immediately by a low pressure event indicates passage of device **10** through the ileocecal sphincter between the narrow small intestines and the more cavernous proximal or ascending colon. A gastrointestinal sample collection process can be initiated by device **10** at any one or combination of these locations based on preset thresholds of radial pressure readings, or based on a pattern of pressure readings as measured by one or more pressure sensors on device **10**.

[0280] Lumen-clearing peristaltic contractions are used by the GI tract to push along large undigestible objects. During these contractions, there is relatively high squeeze pressure around device **10**, with close contact between device **10** and the lumen of the GI tract. In another embodiment, elevated squeeze pressures are used to trigger sample collection events by device **10**. In this manner, samples are obtained from the mucosal surfaces directly, versus from the bulk fluid surrounding device **10** at times when the GI tract is not squeezing device **10**. The bulk fluid in the GI tract normally comprises mainly digestive fluids and food particles, which are different from the cells and molecules on or in the GI mucosal layer itself. Capturing samples from the mucosal layer directly during a peristaltic squeeze event, therefore, has the advantage of enriching the sample for microbes and host cells, along with the related intercellular molecules in, and adjacent to, the mucosal surfaces.

[0281] In some embodiments, the electrical impedance or resistance between two or more electrodes physically segregated on the surface of device **10** can be used to determine the location of device **10** within the GI tract. By way of example, the small intestines tend to squeeze device **10** nearly continuously which will lower the impedance or resistance of electricity between the electrodes. Alternatively, the

stomach and the colon are larger organs and as such do not routinely come into intimate contact with all surfaces of device **10**, thereby leading to increased impedance or resistance of electricity between the electrodes. A gastrointestinal sample collection process can be initiated by device **10** at any one or combination of these locations based on preset thresholds of impedances, or based on a pattern of impedance readings as measured by electrodes on the device.

[0282] In some embodiments, device **10** comprises an accelerometer or other triangulation tracking sensor that detects and records the motion of device **10** in the GI tract in a time stamped manner. Optionally, a second accelerometer can be worn outside GI tract of the user to negate gross body movements of the user and only look at relative movement of device **10** within the body. By way of example, the external accelerometer can be in a smart phone device carried by the user. By doing so, transit times and a virtual path of device **10** through the GI tract can be reconstructed to associate the collected gastrointestinal samples to specific regions of the GI tract.

[0283] In some embodiments, device **10** comprises a sensor that activates when moisture is detected in collecting member **18**, indicating the collection of a gastrointestinal sample. Activation of the moisture sensor triggers an identification element such as an active radio frequency identification (RFID) chip to indicate the time or position of device **10** at the initiation of sample collection.

[0284] In some embodiments, the rate of exposure of collecting member **18** to the GI tract is not uniform. Sampling occurs at different rates in different parts of the GI tract based on the expected or measured transit time of device **10** through the GI tract. For example, the sampling rate is at least two times faster than normal in the mouth and esophagus where transit is fastest, normal in the stomach and small intestine where transit time slows, and half the normal rate or less in the colon where transit time is slowest. In this manner, the sampling rate can vary by a factor of 4 or more to achieve more uniform sampling of device **10** per distance of GI tract covered.

[0285] In some embodiments, device **10** contains a radio-opaque marker to make the capsule visible in x-rays or fluoroscopy.

[0286] In some embodiments, device **10** comprises a radio frequency ID (RFID) chip to make the capsule detectable with an external reader.

[0287] In some embodiments, device **10** comprises a bar code readable by an external reader.

[0288] In some embodiments, sample collection is initiated by exposing collecting member **18** to fluid communication with the GI tract using an actuator driven by a potential or chemical energy power source in device **10**. At the end of the sample collection process, sealing of collecting member **18** is accomplished via an actuator driven by a second potential or chemical energy power source in device **10**. By way of example, the collecting member is movable or the opening **42** openable by a spring or elastic member, which in turn is restrained from expanding by a fuse wire. At the time of sample collection, the fuse wire is burned by an electric current and the spring or elastic element expands in order to expose collecting member **18** to the GI tract. At the end of the sampling window, collecting member **18** is moveable into a sealed position or the opening **42** is sealed by a second spring or elastic element which is also restrained by a fuse. At the end of sample collection, this second fuse is burned by an electrical

current and the second spring or elastic element expands in order to seal the collecting member from further exposure to the GI tract.

5 [0289] In some embodiments, a valve blocks opening 42. At the desired time of sampling, an electrical signal or resistive heating element opens the valve and gastrointestinal samples 40 flow through opening 42 into an elastically collapsed or under-pressured collecting member 18 via one way valve 24. In this manner, only a single signal is required to initiate sample collection and isolate gastrointestinal samples inside collecting member 18.

10 [0290] In some embodiments, the valve is a membrane that blocks opening 42 and the resistive heating element destroys the membrane. In some embodiments, the membrane blocking opening 42 comprises a metal.

[0291] In some embodiments, the membrane blocking opening 42 comprises a polymer.

[0292] In some embodiments, the membrane blocking opening 42 comprises a resistive heater.

[0293] In some embodiments, the membrane blocking opening 42 comprises poly(L-lactic acid) or poly(lactide-co-glycolide).

15 [0294] In some embodiments, the valve blocking opening 42 comprises a material that changes phases from solid to liquid upon heating. Examples of such materials comprise polyethylene glycol, paraffin and other waxes. The material undergoes a change of volume due to the phase change that is utilized as a linear displacement to open a normally closed valve to enable sampling of gastrointestinal samples in a time window of 1 minute to 1 hour before re-sealing the valve when the electrical current is
20 stopped.

[0295] In some embodiments, the membrane blocking opening 42 is burst due to high pressure generated by a gas.

[0296] In some embodiments, a flexible tube connecting opening 42 to collecting member 18 is pinched closed by a spring element.

25 [0297] In some embodiments, a flexible tube connecting opening 42 to collecting member 18 is kinked in order to close and seal the tube.

[0298] In some embodiments, opening 42 is controlled by a bi-stable or flip-flop valve that requires no energy to be in an open or closed configuration, but rather only consumes energy in transitioning between the open and closed states.

30 [0299] In some embodiments, device 10 comprises an electrical or chemical power source that causes a phase change in a material that subsequently enables or triggers sample collection.

[0300] In some embodiments, device 10 is placed in capsule 72 comprising covering element 30 that targets device 10 to be exposed to the GI tract fluids in the region of the duodenum where the pH is around 5-6. When device 10 is exposed for the first time to GI tract fluids in the duodenum, a moisture
35 sensitive switch is activated that starts a timing circuit that triggers sampling events at set time points to sample specific sampling regions of the small intestine and colon based on known transit times through these regions. In this manner, a pH range is used for initial delivery of device 10 to the intestines and then thereafter an electronic timing circuit triggers the sampling in a pH independent manner.

[0301] In some embodiments, device **10** counts the number of peristaltic pressure waves of the GI tract that act on device **10** via a sensor. Device **10** uses the number of peristaltic pressure waves to estimate the distance device **10** has moved through the GI tract as a sort of “odometer”. Device **10** uses the number of peristaltic pressure waves to guide the sampling activity or release profile of an active agent.

[0302] Device **10** becomes embedded in stool while in the colon. At the time of defecation, device **10** may be completely embedded inside stool that has the consistency of clay. It is necessary to recover device **10** and extract the gastrointestinal sample therein for further analysis in the easiest and most user-friendly manner possible.

[0303] In some embodiments, a toilet collection device comprises slots with a width just slightly smaller than the diameter of device **10** and a length at least as long as the overall length of device **10**. Slots are more efficient than holes in letting through the stool and retaining device **10**.

[0304] In some embodiments, a toilet collection device comprises a rotatable mechanical disrupter, such as an impeller, paddle wheel or whisk, which is positioned beneath the water level of the toilet bowl and rotates to mechanically break up the stool through a passageway. The flushing of the toilet creates a flow of water that helps moves the stool through the mechanical disrupter and the passageway, leaving behind just device **10**.

[0305] In some embodiments, a collection kit comprises an axial element with radially protruding elements that when spun around the axial axis breaks up the stool and snares device **10**. This retrieval device is particularly suited for capturing device **10** when in the form of an elongated tube. The axial element can be retracted with the collected device **10** into a sheath for hygienic transfer of device **10** from the toilet to a secondary collection container.

[0306] In some embodiments, a kit is provided comprising device **10** and any of the collection devices described above.

[0307] In some embodiments, device **10** is used as a delivery device. Device **10** is pre-loaded with an active agent outside the body before being swallowed. The portion of collecting member **18** that is exposed to the gastrointestinal fluids releases the active agent into the GI tract. By controlling the time, duration and rate of exposure of collecting member **18** to the GI tract, it is possible to control the rate and location of dispensing of the active agent.

[0308] In some embodiments, device **10** serves a dual purpose of being a delivery device that releases an active agent in the GI tract, while simultaneously collecting gastrointestinal samples. Device **10** can therefore analyze the effect of the active agent being dispensed.

[0309] Additional objects, advantages, and novel features of the present invention will become apparent to one ordinarily skilled in the art upon examination of the following examples, which are not intended to be limiting. Additionally, each of the various embodiments and aspects of the present invention as delineated hereinabove and as claimed in the claims section below finds experimental support in the following examples.

[0310] EXAMPLES

[0311] Reference is now made to the following examples, which together with the above disclosure, illustrate the invention in a non-limiting fashion.

[0312] Example 1. Long tube-shaped collecting member

[0313] There is a concern that any indigestible device might be retained in a patient's GI tract. The larger the diameter of device, the more likely the device is to be retained. Therefore, there is a safety advantage in reducing the diameter of the sampling device to the minimum possible, while still collecting the maximal volume of sample.

[0314] In this example, a 50 cm long hollow tube of silicone rubber with an external diameter of 2.0 mm and an internal diameter of 1.5 mm was used as body and the inner lumen formed the collecting member. This tube, when unfolded, is highly unlikely to be retained by the GI tract. A glass capsule micro-RFID tag that serves to both identify the device and also as a radio opaque marker was inserted into one end of the tube which was then sealed with silicone glue. Starting with the sealed end, the tube was coiled around itself tightly enough to collapse the lumen, thereby removing almost all of the gas therein, while at the same time being embedded in a water soluble adhesive that kept the tube from unraveling once the adhesive was dry. The coiled tube, with the dry adhesive keeping it in the shape of a tight coil, was placed inside a size 00 HPMC capsule. The capsule was covered with an enteric coating as the covering element, forming the finished device.

[0315] The device capsule was swallowed. The enteric coating kept the body intact until the device was in the proximal small intestines, at which point the enteric covering element and external capsule dissolved. The adhesive holding the coiled tube-shaped body started to dissolve, and the body started to uncoil due to the inherent elasticity and low hysteresis of silicone, and thereby draw in gastrointestinal samples into the sampling opening of the tube which was on the outer most layer of the coil. As the adhesive continued to degrade due to moisture in the GI tract, the tube uncoiled more, drawing in more gastrointestinal sample into the tube. The tube passed into the right colon where it continued to uncoil and collect gastrointestinal samples. Overall sampling time was approximately 6 hours until the adhesive completely degraded and the tube shaped body was completely uncoiled, and the sampling process complete.

[0316] The device passed in the stool the next day and was collected from the toilet using a rotating hooked retrieval wand. The collected gastrointestinal samples formed a linear array inside the 50 cm long tube, with the small intestine samples closest to the sealed end of the tube and the colonic sample closer to the open end of the tube. 455 microliters of gastrointestinal samples were recovered from the tube and analyzed. The recovered samples had a pH of 5.5 towards the closed end of the tube, representing the proximal small intestine, rising to a pH of 8 towards the middle of the tube representing the jejunum and ileum, and ending with pH of 6 towards the open end of the tube, representing samples taken from the ascending colon. Relative to the 900 microliter volume of the ingested HPMC size 00 capsule, the collected volume percentage was 455 microliters / 900 microliters, or 51%.

[0317] The device as described in this example is highly unlikely to be retained in the GI tract of a patient, since all of the components of device dissolve in the GI tract within several hours, with the

exception of a 50 cm long silicone tube that is only 2 mm in diameter with a maximal cross sectional area of only 3.1 square millimeters. Such a long and slender tube does not have sufficient size or cross sectional area to block any part of the human GI tract for a patient who is asymptomatic of a pre-existing intestinal stricture.

5 **[0318]** Example 2. Segmented collecting member.

[0319] In this example, a segmented closed-ended tube-shaped body was made from silicone with a duck-bill one-way valve at the sampling opening as illustrated in Figures 34. The body is 5 mm in outer diameter and 65 mm long. The collecting member is divided into 4 segments, each approximately 13 mm long, separated by narrow portions 2.2 mm in outer diameter to enable axial flexure of the device while moving through the highly-curved small intestine. The thickness of the body walls is 0.3 mm and made of shore 70 silicone so that the maximal outward radial pressure exerted by expanding tube-shaped body is about 50 grams-force per cm length of tube-shaped body. The collecting member was radially collapsed to minimize the lumen volume and wound in a spiral fashion with axial offset about a central axis as illustrated in Figure 36 and packaged inside a size 2 HPMC capsule.

15 **[0320]** Five devices were prepared in an identical manner except for the enteric coatings applied to the outside surface of the HPMC capsule of each, as specified in Table 5 below. Once the covering element dissolves, the body expands in approximately 1 minute to sample only one specific region of the GI tract.

Device number	Target pH of enteric coating (covering element)	Target region	pH of recovered samples
1	None	Stomach	1.8
2	pH 5.5	Duodenum	5.8
3	pH 6.5	Jejunum	6.9
4	pH 7.5	Ileum	8.0
5	pH >6.5 over pH<6.5 (“inverse pH coating”)	Ascending colon	6.7

Table 5: Coating of five sampling devices

20 **[0321]** A subject swallowed the five devices comprising the segmented collecting member. After recovery from the stool of the subject the next day, the devices contained approximately 1 ml of gastrointestinal samples each, which resulted in a collection volume percentage of 277% relative to the 0.36 ml volume of the size 2 capsule that contained the device at the time of swallowing. The recovered samples had pH levels as per Table 5 above. The pH of the samples was used as a position identification parameter to verify the location of sampling as per Table 4.

25 **[0322]** A gas chromatography - mass spectrometric analysis was conducted on the recovered samples and a representative sample of 30 metabolites out of the 657 metabolites that were positively identified and quantified is shown in Table 6 below. The higher the number, the more of that specific metabolite is present in that region of the GI tract. The variability of absolute numbers of each metabolite across the columns informs us as to the biochemical and physiological functions occurring in that region

of the GI tract. This demonstrates the importance of tightly controlling the location of sampling in the different regions of the GI tract, versus simply measuring at a single point or profiling the metabolites in the stool. The metabolites with only a number as their identifier are uncharacterized metabolites, which demonstrates the ability of the present invention to identify novel metabolites and profile their presence in the different regions of the GI tract.

5

Metabolite	Stomach	Duodenum	Jejunum	Ileum	Ascending colon
Urea	300,659	393,582	300,122	5,147	422,339
Hydroxylamine	95,562	257,776	197,103	173,725	126,381
209175	252,852	220,380	239,197	220,437	241,682
Valine	889,576	130,076	307,284	139,980	171,653
Isoleucine	589,914	122,106	208,208	124,524	176,824
Alanine	774,812	113,268	247,677	138,271	158,737
Oxoproline	339,857	100,258	136,278	35,704	76,562
Serine	399,685	98,964	32,943	61,435	57,736
Leucine	995,892	90,992	330,123	104,143	269,620
Tyrosine	533,684	90,914	120,659	125,259	137,611
Glycine	576,710	84,336	761,457	42,345	61,797
Stearic acid	74,727	75,973	98,124	70,426	303,496
Butanoic acid	13,504	73,886	24,125	1,591	3,193
Glycerol	533,347	69,212	282,590	56,275	1,424,295
137	68,306	62,245	68,693	65,887	64,366
Proline	527,366	58,763	100,072	60,047	69,112
Phenylalanine	297,498	54,945	80,107	70,563	77,771
Hexuronic acid	156,779	48,840	83,768	911	50,835
Uric acid	75,040	48,487	14,345	574	17,497
120562	37,784	40,918	48,675	32,659	12,970
107077	37,784	40,918	43,483	38,261	16,187
209688	33,755	40,918	48,675	38,261	16,187
Aspartic acid	242,003	39,222	76,749	57,326	33,190
479	37,784	34,996	48,675	38,261	16,187
3228	40,755	28,749	32,208	69,490	31,987
Galactinol	1,046	25,008	3,381	1,092	26,618
Threonine	201,986	24,770	15,521	13,671	23,229
321061	19,642	23,832	7,051	7,782	6,183
Galactose	5,196	22,778	11,248	31,515	540,089
Cholesterol	49,545	22,316	36,689	21,710	83,790

Table 6: Metabolites found in the different regions of the GI tract using the sampling device of Example 2.

- [0323]** When a feature or element is herein referred to as being “on” another feature or element, it can be directly on the other feature or element or intervening features and/or elements may also be present. In contrast, when a feature or element is referred to as being “directly on” another feature or element, there are no intervening features or elements present. It will also be understood that, when a feature or element is referred to as being “connected”, “attached” or “coupled” to another feature or element, it can be directly connected, attached or coupled to the other feature or element or intervening features or elements may be present. In contrast, when a feature or element is referred to as being “directly connected”, “directly attached” or “directly coupled” to another feature or element, there are no intervening features or elements present. Although described or shown with respect to one embodiment, the features and elements so described or shown can apply to other embodiments. It will also be appreciated by those of skill in the art that references to a structure or feature that is disposed “adjacent” another feature may have portions that overlap or underlie the adjacent feature.
- [0324]** Terminology used herein is for the purpose of describing particular embodiments only and is not intended to be limiting of the invention. For example, as used herein, the singular forms “a”, “an” and “the” are intended to include the plural forms as well, unless the context clearly indicates otherwise. It will be further understood that the terms “comprises” and/or “comprising,” when used in this specification, specify the presence of stated features, steps, operations, elements, and/or components, but do not preclude the presence or addition of one or more other features, steps, operations, elements, components, and/or groups thereof. As used herein, the term “and/or” includes any and all combinations of one or more of the associated listed items and may be abbreviated as “/”.
- [0325]** Spatially relative terms, such as “under”, “below”, “lower”, “over”, “upper” and the like, may be used herein for ease of description to describe one element or feature’s relationship to another element(s) or feature(s) as illustrated in the figures. It will be understood that the spatially relative terms are intended to encompass different orientations of the device in use or operation in addition to the orientation depicted in the figures. For example, if a device in the figures is inverted, elements described as “under” or “beneath” other elements or features would then be oriented “over” the other elements or features. Thus, the exemplary term “under” can encompass both an orientation of over and under. The device may be otherwise oriented (rotated 90 degrees or at other orientations) and the spatially relative descriptors used herein interpreted accordingly. Similarly, the terms “upwardly”, “downwardly”, “vertical”, “horizontal” and the like are used herein for the purpose of explanation only unless specifically indicated otherwise.
- [0326]** Although the terms “first” and “second” may be used herein to describe various features/elements (including steps), these features/elements should not be limited by these terms, unless the context indicates otherwise. These terms may be used to distinguish one feature/element from another feature/element. Thus, a first feature/element discussed below could be termed a second feature/element,

and similarly, a second feature/element discussed below could be termed a first feature/element without departing from the teachings of the present invention.

[0327] Throughout this specification and the claims which follow, unless the context requires otherwise, the word “comprise”, and variations such as “comprises” and “comprising” means various components can be co-jointly employed in the methods and articles (e.g., compositions and apparatuses including device and methods). For example, the term “comprising” will be understood to imply the inclusion of any stated elements or steps but not the exclusion of any other elements or steps.

[0328] As used herein in the specification and claims, including as used in the examples and unless otherwise expressly specified, all numbers may be read as if prefaced by the word “about” or “approximately,” even if the term does not expressly appear. The phrase “about” or “approximately” may be used when describing magnitude and/or position to indicate that the value and/or position described is within a reasonable expected range of values and/or positions. For example, a numeric value may have a value that is +/- 0.1% of the stated value (or range of values), +/- 1% of the stated value (or range of values), +/- 2% of the stated value (or range of values), +/- 5% of the stated value (or range of values), +/- 10% of the stated value (or range of values), etc. Any numerical values given herein should also be understood to include about or approximately that value, unless the context indicates otherwise. For example, if the value “10” is disclosed, then “about 10” is also disclosed. Any numerical range recited herein is intended to include all sub-ranges subsumed therein. It is also understood that when a value is disclosed that “less than or equal to” the value, “greater than or equal to the value” and possible ranges between values are also disclosed, as appropriately understood by the skilled artisan. For example, if the value “X” is disclosed the “less than or equal to X” as well as “greater than or equal to X” (e.g., where X is a numerical value) is also disclosed. It is also understood that the throughout the application, data is provided in a number of different formats, and that this data, represents endpoints and starting points, and ranges for any combination of the data points. For example, if a particular data point “10” and a particular data point “15” are disclosed, it is understood that greater than, greater than or equal to, less than, less than or equal to, and equal to 10 and 15 are considered disclosed as well as between 10 and 15. It is also understood that each unit between two particular units are also disclosed. For example, if 10 and 15 are disclosed, then 11, 12, 13, and 14 are also disclosed.

[0329] Although various illustrative embodiments are described above, any of a number of changes may be made to various embodiments without departing from the scope of the invention as described by the claims. For example, the order in which various described method steps are performed may often be changed in alternative embodiments, and in other alternative embodiments one or more method steps may be skipped altogether. Optional features of various device and system embodiments may be included in some embodiments and not in others. Therefore, the foregoing description is provided primarily for exemplary purposes and should not be interpreted to limit the scope of the invention as it is set forth in the claims.

[0330] The examples and illustrations included herein show, by way of illustration and not of limitation, specific embodiments in which the subject matter may be practiced. As mentioned, other

embodiments may be utilized and derived there from, such that structural and logical substitutions and changes may be made without departing from the scope of this disclosure. Such embodiments of the inventive subject matter may be referred to herein individually or collectively by the term “invention” merely for convenience and without intending to voluntarily limit the scope of this application to any
5 single invention or inventive concept, if more than one is, in fact, disclosed. Thus, although specific embodiments have been illustrated and described herein, any arrangement calculated to achieve the same purpose may be substituted for the specific embodiments shown. This disclosure is intended to cover any and all adaptations or variations of various embodiments. Combinations of the above embodiments, and other embodiments not specifically described herein, will be apparent to those of skill in the art upon
10 reviewing the above description.

CLAIMS

What is claimed is:

1. A device for collecting gastrointestinal samples comprising
5 a capsule; and
a tube-shaped body wound, twisted or folded within said capsule, the body comprising an open end and a closed end.
2. The device of claim 1, wherein the tube-shaped body comprises a narrowed portion configured to limit a sampling rate of the device.
- 10 3. The device of claim 1, wherein the tube-shaped body comprises an internal diameter of about 0.2 to 2.5 mm.
4. The device of claim 1, wherein the tube-shaped body comprises an external diameter of about 0.4 to 3.0 mm.
5. The device of claim 1, wherein the tube-shaped body comprises an external diameter of about 5.0 to
15 7.0 mm.
6. The device of claim 1, wherein the tube-shaped body comprises a length of about 1 to 200 cm.
7. The device of claim 1, wherein the tube-shaped body has an aspect ratio of 5 or greater.
8. The device of claim 1, wherein movement of gastrointestinal samples into the tube-shaped body is driven by a pressure differential between a radially collapsed and radially expanded body.
- 20 9. The device of claim 1, wherein the open end of the tube-shaped body comprises a one way valve.
10. The device of claim 9, wherein the cracking pressure of the one way valve is in the range of 0.03 to 15 pounds per square inch.
11. The device of claim 1 wherein the maximal outward radial pressure exerted by expanding tube-shaped body is in the range of 10 to 150 grams-force per cm length of body.
- 25 12. The device of claim 1, wherein the flow of fluid sample through the open end of the body is between 1 to 500 microliters per hour.
13. The device of claim 1, wherein a spatial resolution of sampling of the device is about +/- 1 foot of a 30 foot long gastrointestinal tract.
14. The device of claim 1 wherein the tube-shaped body is hollow.
- 30 15. The device of claim 1 wherein the tube-shaped body has a collapsed internal lumen.
16. The device of claim 1 wherein the tube-shaped body is wound as a spiral around a central axis.
17. The device of claim 16, wherein the spiral is axially offset around said central axis.
18. The device of claim 1, wherein the tube-shaped body is twisted around a central axis to form a helix or coil.
- 35 19. The device of claim 18, wherein the tube-shaped body is twisted around a central axis to form a super-helix or super-coil.
20. The device of claim 1 wherein the tube-shaped body is folded into an accordion configuration.

21. The device of claim 1 wherein the tube-shaped body is folded along a central axis into a creased configuration.
22. The device of claim 1 wherein the tube-shaped body is not invaginated when placed within the capsule.
- 5 23. The device of claim 1 wherein the maximal diameter of the tube-shaped body is smaller than the diameter of the capsule.
24. The device of claim 1, wherein the tube-shaped body is configured to transition to its relaxed state upon dissolution of the capsule.
25. The device of claim 1, wherein the capsule is ruptured by expansion force of the tube-shaped body.
- 10 26. The device of claim 1, wherein the tube-shaped body is configured to transition to its relaxed state upon degradation of a covering element on the tube-shaped body.
27. The device of claim 1, wherein the capsule comprises one or more covering elements surrounding the tube-shaped body.
28. The device of claim 1, wherein the capsule comprises at least a first and a second pH sensitive
15 degradable covering element surrounding the tube-shaped body.
29. The device of claim 1, wherein at least one of the first and second covering elements degrades at a pH of about 6.4-7 or lower.
30. The device of claim 1, wherein the device is configured to sample gastrointestinal contents for about 1 minute to 1 hour.
- 20 31. The device of claim 1 wherein the device is configured to sample gastrointestinal contents for about 1 hour to 8 hours.
32. The device of claim 1, wherein different portions of the wound, twisted or folded tube-shaped body comprise different degradable covering elements.
33. The device of claim 32, wherein covering elements positioned closer to the open end are configured to
25 degrade faster than covering elements positioned farther from the open end.
34. The device of claim 32, wherein covering elements positioned closer to the open end are configured to degrade at a lower pH than covering elements positioned farther from the open end.
35. The device of claim 1, wherein a second end of the tube-shaped body is in fluid communication with an opening in the capsule.
- 30 36. The device of claim 1, wherein the tube-shaped body is coiled to form a plurality of flat disks.
37. The device of claim 36, wherein the tube-shaped body is coiled to form three flat disks.
38. The device of claim 37, wherein each disk is configured to uncoil at a different rate to target different portions of the gastrointestinal tract.
39. The device of claim 1, wherein the open end is positioned on an inside of the wound, twisted, or
35 folded tube-shaped body.
40. The device of claim 1, wherein the open end is positioned on an outside of the wound, twisted, or folded tube-shaped body.

41. The device of claim 1, wherein the capsule comprises a split capsule configured to split in the right colon.
42. The device of claim 1, wherein the capsule comprises a tube-shaped body configured to unfold in the right colon.
- 5 43. The device of claim 1, wherein the capsule comprises an open end of a tube-shaped body configured to open in the right colon.
44. The device of claim 1, wherein a collection volume percentage of the device is at least 50%.
45. The device of claim 1, wherein a collection volume percentage of the device is at least 100%.
46. The device of claim 1, wherein a dead volume of the device is less than about 15%.
- 10 47. The device of claim 1, wherein a volume of the device is less than about 2 ml.
48. The device of claim 1, wherein a volume of the device is less than about 1 ml.
49. The device of claim 1, further comprising a detector configured to detect a location identification parameter.
50. The device of claim 49, wherein the location identification parameter comprises at least one of pH,
15 color, bacterial count, bacterial identity, hormones, dissolved gases, enzymatic activity, biochemical markers, capsule movement patterns, and intraluminal pressure.
51. The device of claim 1, further comprising an actuator.
52. The device of claim 51, wherein the actuator comprises an elastic material.
53. The device of claim 51, wherein the actuator comprises a hollow bladder.
- 20 54. The device of claim 51, wherein the actuator is spaced apart from an end of the capsule, creating a space between the actuator and the capsule.
55. The device of claim 54, wherein the capsule comprises an orifice that is positioned on the body within the space.
56. The device of claim 54, wherein the orifice comprises a movable seal configured to open or close the
25 orifice.
57. The device of claim 54, wherein the orifice comprise a degradable covering element.
58. The device of claim 51, wherein the actuator comprise a first collapsed state and a second expanded state.
59. The device of claim 54, wherein the space comprises a fluid.
- 30 60. The device of claim 1, wherein a length of the tube-shaped body does not change during the sample collection process.
61. A method of producing a device for sampling gastrointestinal contents comprising
winding, twisting or folding a tube-shaped body; and
35 placing said wound, twisted or folded tube-shaped body inside a capsule.
62. The method of claim 61 wherein the internal lumen of the wound, twisted or folded tube-shaped body is radially collapsed.

63. The method of claim 61 wherein said tube-shaped body or an opening of said tube-shaped body is covered with an enteric degradable material.
64. A method of sampling gastrointestinal contents comprising
- i. delivering the device of claim 1 into the gastrointestinal tract;
 - 5 ii. allowing flow of gastrointestinal contents into said tube-shaped body; and
 - iii. recovering said device from the stool.
65. The method of claim 64, wherein radial expansion of the collapsed internal lumen of said tube-shaped body causes said flow of gastrointestinal contents into said tube-shaped body.
66. A method of sampling gastrointestinal contents comprising
- 10 delivering a device comprising a capsule; and tube-shaped body wound, twisted, or folded within the capsule, into the gastrointestinal tract; and
- allowing flow of gastrointestinal contents into the tube-shaped body, and recovering the device from the stool.
67. The method of claim 66, wherein allowing flow comprises radially expanding the tube-shaped
- 15 body.
68. The method of claim 67, wherein radially expanding the tube-shaped body comprises dissolving the capsule.
69. The method of claim 67, wherein radially expanding the tube-shaped body comprises degradation of a covering element on the tube-shaped body or on the capsule.
- 20 70. A device for collecting gastrointestinal samples comprising
- a body;
- an opening on a sidewall of the body;
- a plurality of plates mounted along a spindle running along a longitudinal axis of the body, adjacent plates comprising a space between them; and
- 25 an actuator configured to displace the plurality of plates along the longitudinal axis of the body, wherein longitudinal displacement causes each space between the plates to align with the opening.
71. The device of claim 70, wherein the plates are disk shaped.
72. The device of claim 70, wherein the plates comprise a same shape as a cross section of the body
- 30 and seal against an inner wall of the body.
73. The device of claim 70, wherein the opening is slit shaped.
74. The device of claim 70, wherein the body is capsule shaped.
75. The device of claim 70, wherein the body comprises a covering.
76. The device of claim 70, further comprising a cavity for stool collection.
- 35 77. The device of claim 70, wherein the actuator comprises an elastic tensile member.
78. A device for collecting gastrointestinal samples comprising
- an outer body;
- a covering element over the outer body;

- an opening in a sidewall of the outer body;
a hollow piston shaped to mate to an inner surface of the outer body, the piston positioned at an end of the body; and
an actuator configured to advance piston to an opposite end of the body to cover the opening in the sidewall.
- 5
79. The device of claim 78, further comprising a second opening positioned diametrically opposed to the opening.
80. The device of claim 78, further comprising an opening in the body.
81. The device of claim 78, wherein the actuator comprises material that expands when wet.
- 10 82. The device of claim 78, wherein the piston is cup shaped.
83. The device of claim 78, wherein the actuator comprises a spring compressed by a moisture degradable restraint.
84. A device for collecting gastrointestinal samples comprising
a body;
15 a collecting member within body;
an opening on the body;
a sealing element movable from a first position where the opening is open to a second position where the opening is sealed by the sealing element; and
an actuator configured to move the sealing element.
- 20 85. The device of claim 84, wherein the collecting member comprises a porous material.
86. The device of claim 84, wherein the actuator is a wet actuator.
87. The device of claim 84, wherein the actuator comprises a dehydrated sponge or superabsorbent material.
88. The device of claim 84, further comprising a wick near the opening.
- 25 89. The device of claim 84, wherein the collecting member is movable from a first position in which the opening is not in fluid communication with the collecting member to a second position in which the opening is in fluid communication with the collecting member.
90. The device of claim 84, wherein the collecting member is movable from a second position in which the opening is in fluid communication with the collecting member to a third position in which the collecting member seals the opening.
- 30 91. The device of claim 84, in which the collecting member is the sealing element.
92. The device of claim 84, wherein the actuator comprises a moisture degradable restraint mechanism.
93. The device of claim 84, wherein the actuator comprises a double trigger moisture degradable restraint mechanism.
- 35 94. The device of claim 84, wherein the actuator is the sealing element.
95. The device of claim 84, further comprising one or more additional openings.
96. The device of claim 84, wherein the actuator comprises a plurality of actuator elements.

97. The device of claim 84, wherein the actuator moves the sealing element into a sealing position within about 1-60 minutes.
98. The device of claim 84, further comprising a covering element.
99. The device of claim 84, further comprising a pH sensitive degradable covering element configured
5 to cover the opening.
100. The device of claim 99, further comprising a second opening covered by a second pH sensitive degradable covering element.
101. A device for collecting gastrointestinal samples comprising
a body;
10 an opening in fluid communication with the body configured to allow gastrointestinal samples to enter the body; and
an external pH sensitive degradable covering element covering the opening; and
an internal pH sensitive degradable covering element covering the opening.
102. The device of claim 101, wherein the external covering element is configured to degrade at or
15 above a target pH level.
103. The device of claim 101, wherein the internal covering element is configured to degrade at or below a target pH level.
104. The device of claim 101, wherein the external covering element is configured to degrade at a pH of about 6.4-7 or above.
- 20 105. The device of claim 101, wherein the internal covering element is configured to degrade at a pH of about 6.4-7 or below.
106. The device of claim 101, wherein the external covering element is configured to dissolve in small intestines.
107. The device of claim 101, wherein the internal covering element is configured to dissolve in the
25 right colon.
108. The device of claim 101, wherein the external covering element comprises anionic acrylic polymers with methacrylic acid as a functional group.
109. The device of claim 101, wherein the internal covering element comprises cationic polymer with dimethylaminoethyl methacrylate as a functional group.
- 30 110. A system for collecting gastrointestinal samples comprising
a first stomach-targeting capsule;
a second small intestine targeting capsule; and
a third colon targeting capsule,
wherein the three capsules are configured to be ingested at the same time.
- 35 111. The system of claim 110, wherein at least one of the capsules comprises a pH sensitive degradable material configured to degrade at an area to be targeted.
112. The system of claim 110, wherein at least one of the capsules comprises an internal pH sensitive degradable covering element and an external pH sensitive degradable material.

113. The system of claim 110, wherein at least one of the capsules comprises a degradable covering element with a thickness selected to degrade at an area to be targeted.
114. The system of claim 110, wherein the capsules comprise a pH sensitive degradable covering element.
- 5 115. The system of claim 114, wherein the covering element is configured to degrade at a pH of about 5.5 or higher.
116. The system of claim 110, wherein the capsules are connected by a flexible connection element.
117. A system of collecting gastrointestinal samples comprising
a capsule;
10 a plurality of collecting members each comprising a hollow body within the capsule and a degradable covering element, the collecting members linked together by connecting members to form a chain.
118. The system of claim 117, wherein the collecting members each comprise an opening.
119. The system of claim 117, wherein filling of a collecting member with sample triggers collection by a subsequent collecting member in the chain.
- 15 120. The system of claim 118, wherein degradation or dissolution of a moisture degradable material exposes the openings of the plurality of the collecting members in a serial manner.
121. The system of claim 117, wherein a length of each collecting member is about 1-30 mm.
122. The system of claim 117, wherein a length of each connecting member is about 1-100 mm.
123. The system of claim 117, wherein the collecting members are arranged linearly or centrally
20 around a spoke.
124. The system of claim 117, wherein at least some of the collecting members comprise a seal or one way valve.
125. The system of claim 117, wherein a negative pressure differential is used to collect a sample.
126. the system of claim 117, wherein the negative pressure differential is caused by capillary forces or
25 expansion of a collapsed member.
127. The system of claim 117, wherein the covering element is configured to degrade based on one of hydration time or pH.
128. The system of claim 117, wherein filling of a collecting member triggers closure or sealing of the collecting member.
- 30 129. The system of claim 128, wherein filling is detected by a target volume, a target duration, or a specific pH.
130. The system of claim 117, wherein some of the collecting members comprise a seal.
131. The system of claim 117, wherein some of the collecting members comprise a flow sensor.

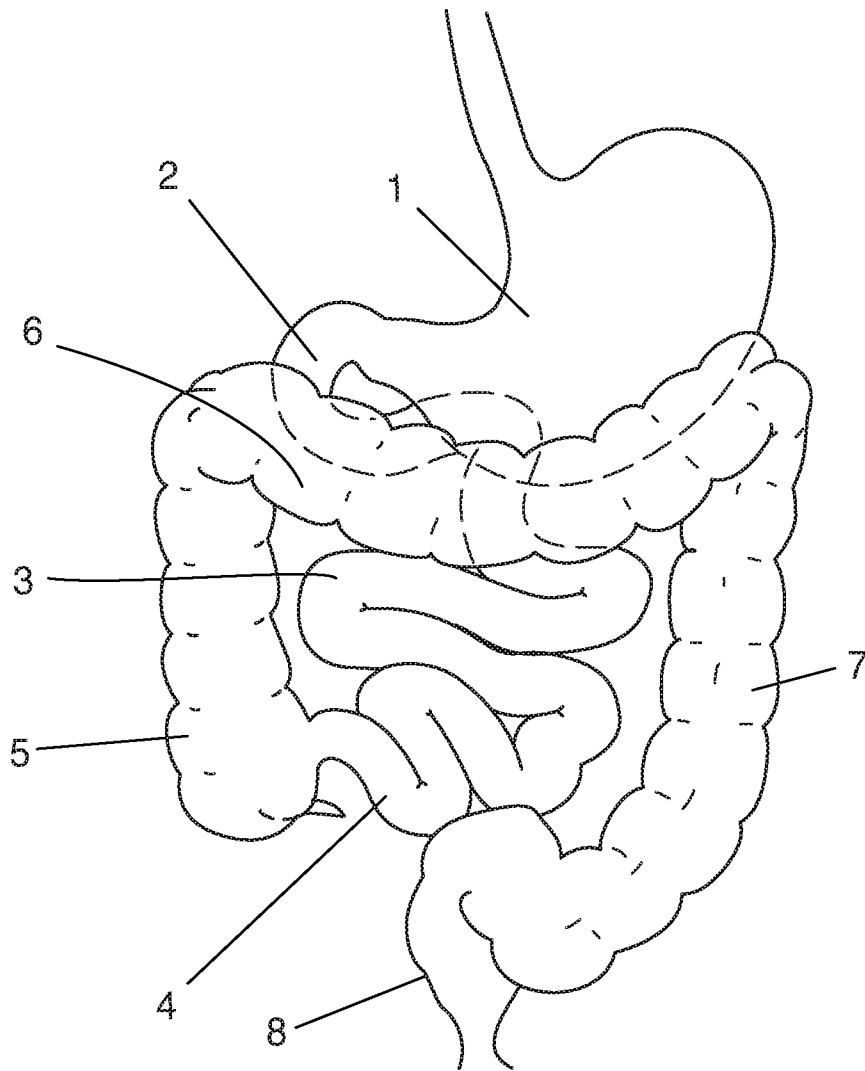

FIG. 1

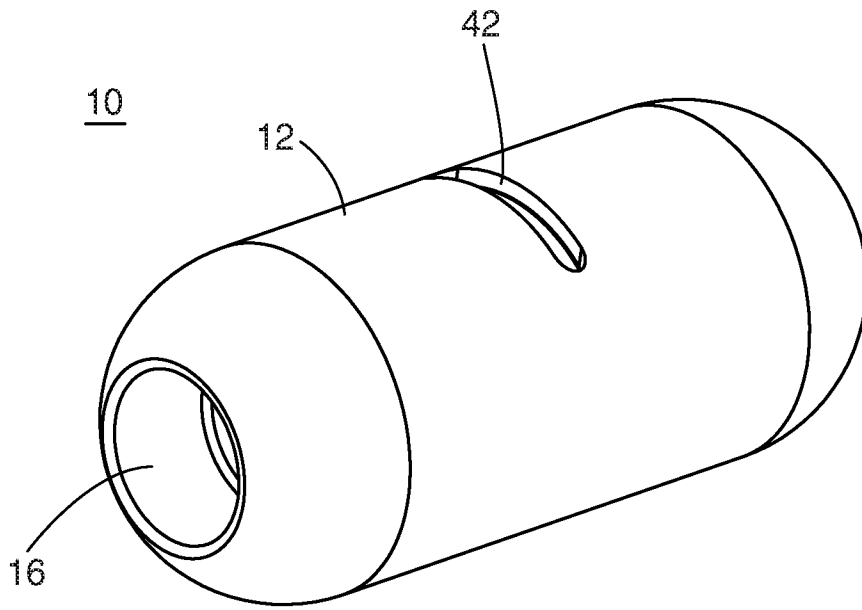

FIG. 2

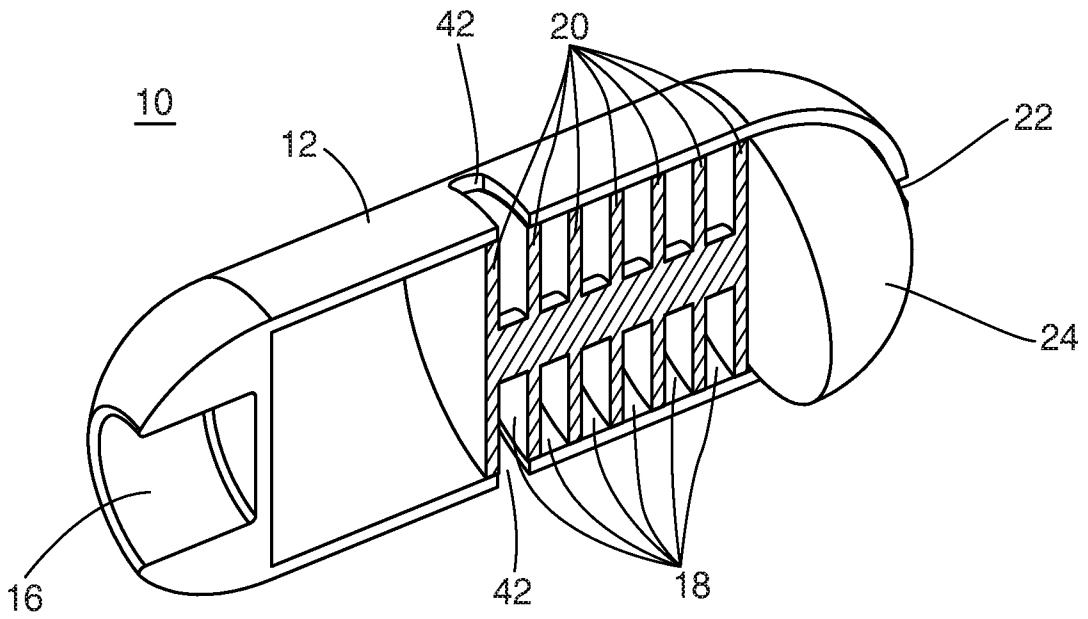

FIG. 3

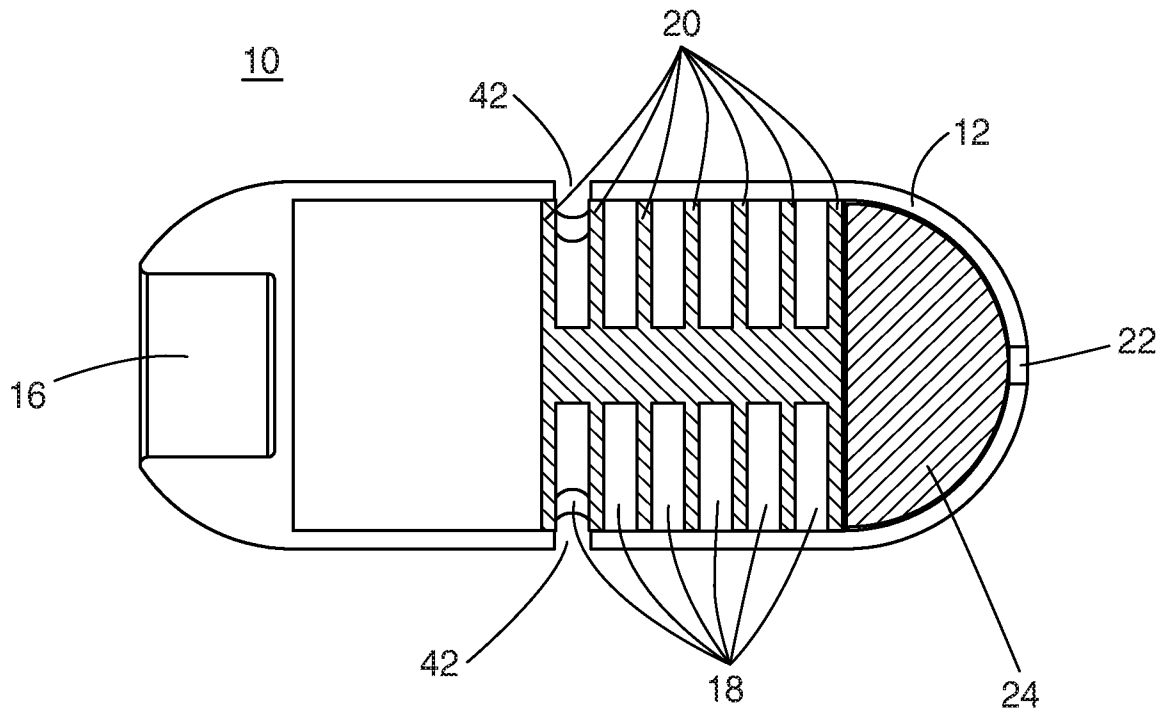

FIG. 4

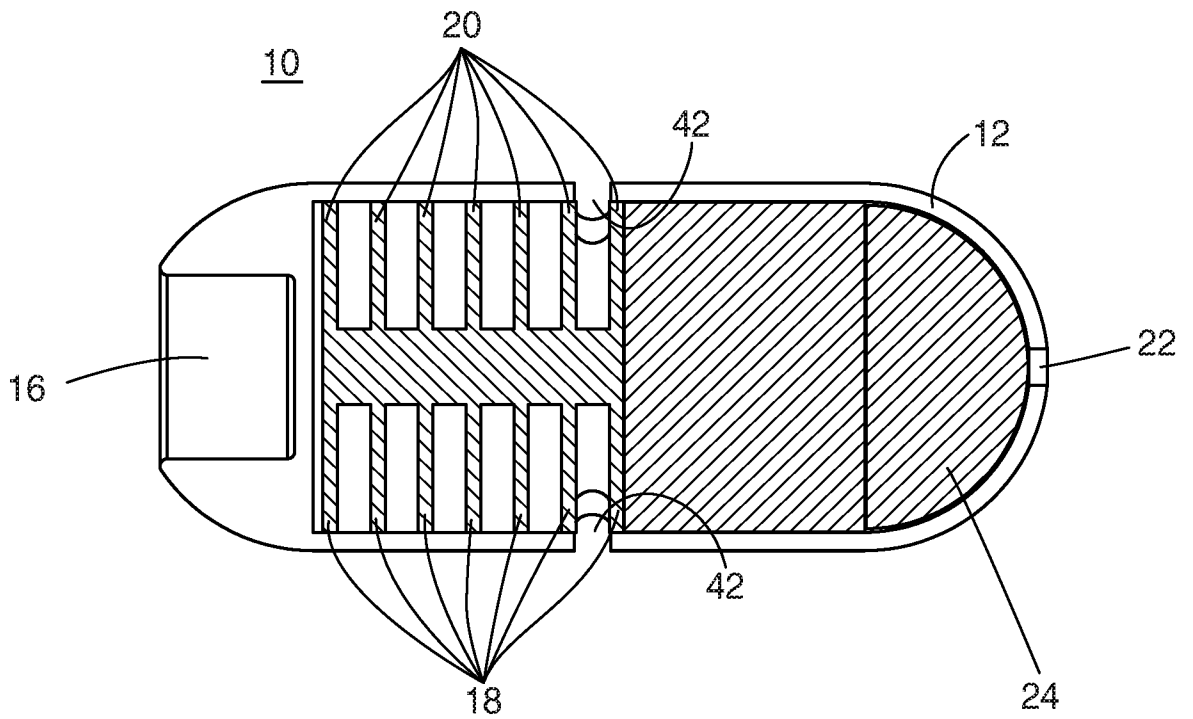

FIG. 5

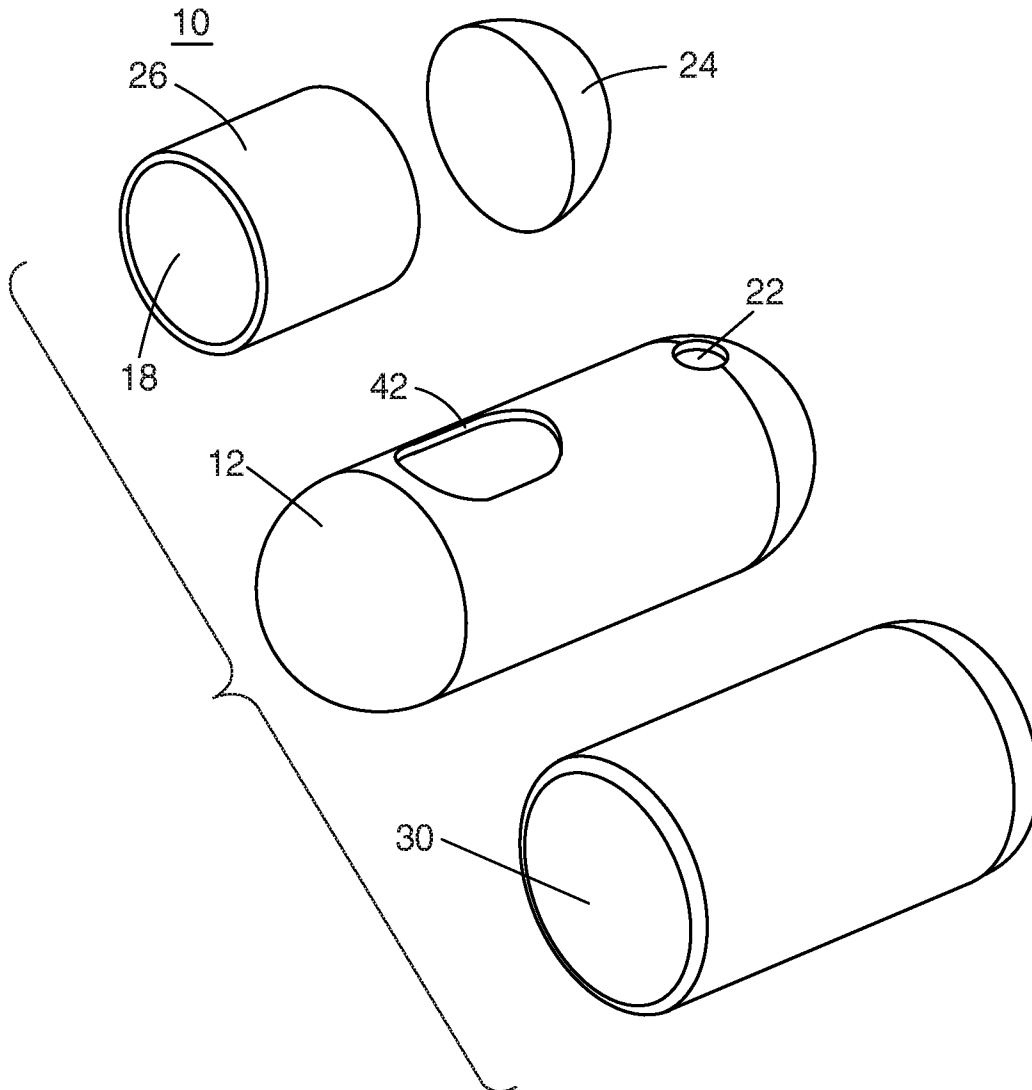

FIG. 6

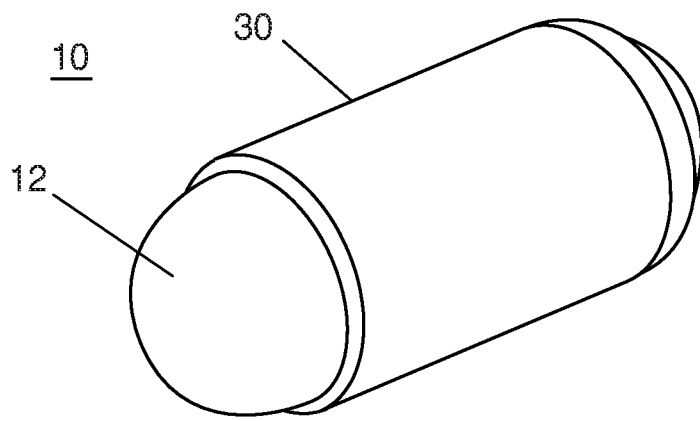

FIG. 7

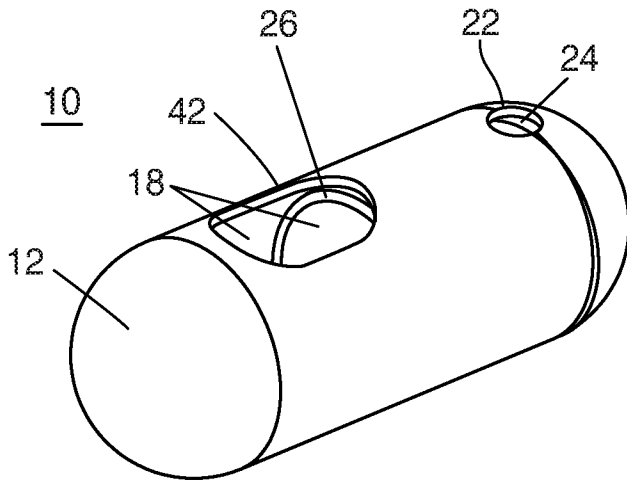

FIG. 8

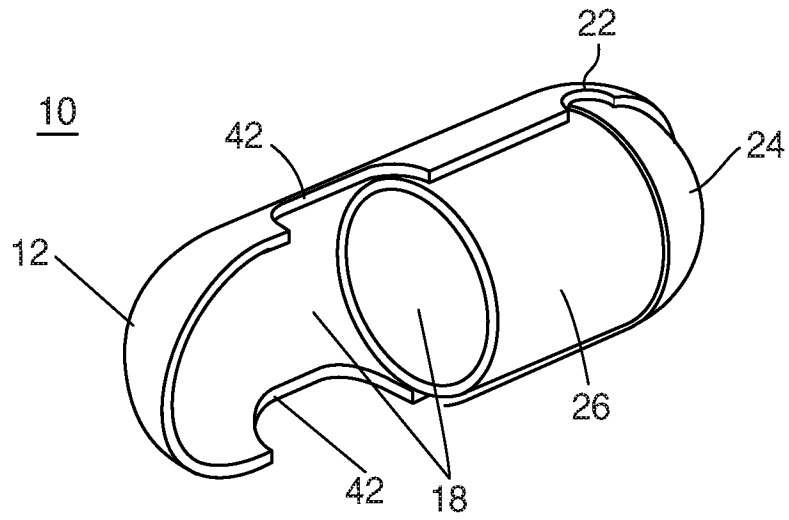

FIG. 9

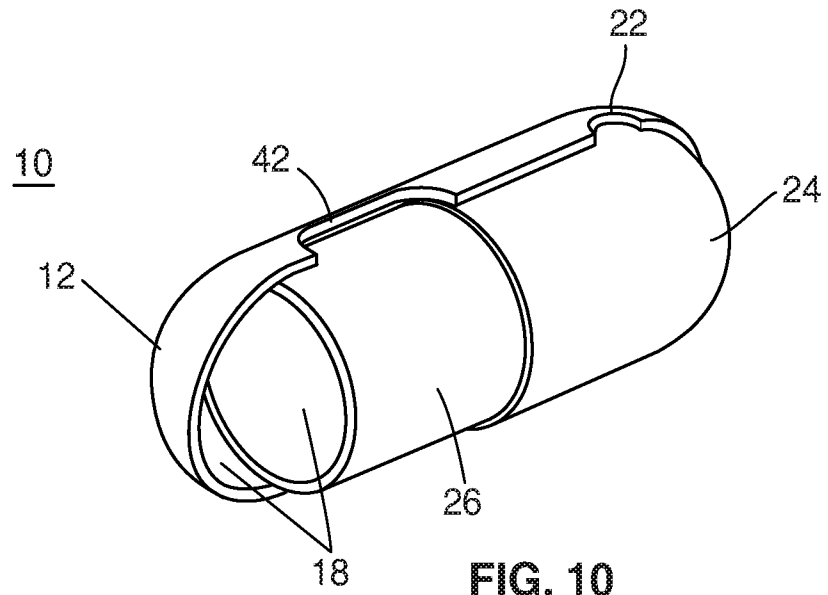

FIG. 10

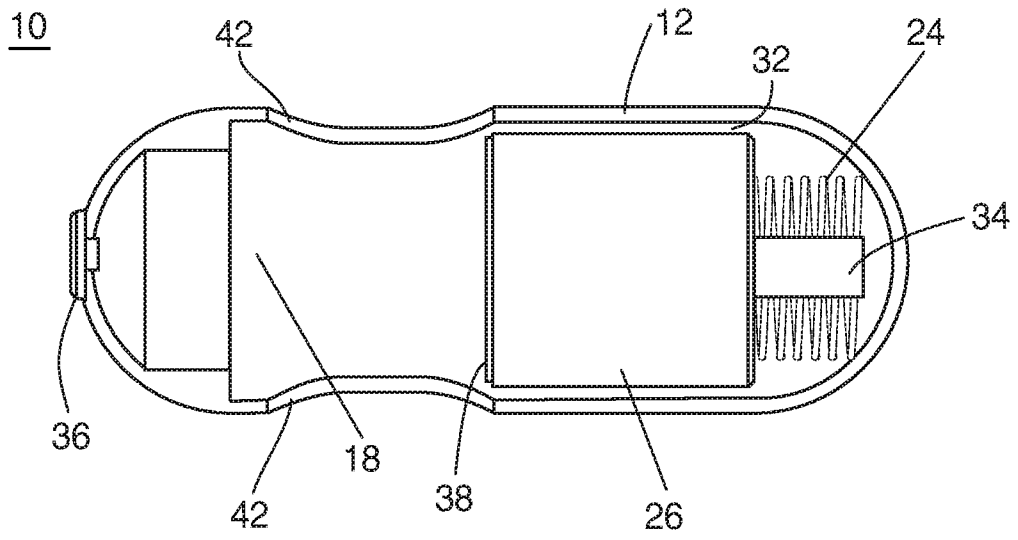

FIG. 11

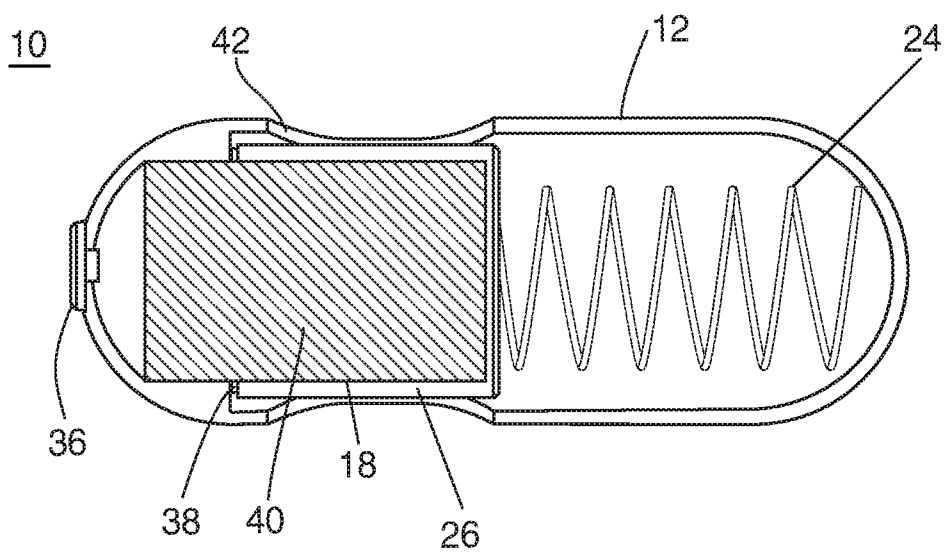

FIG. 12

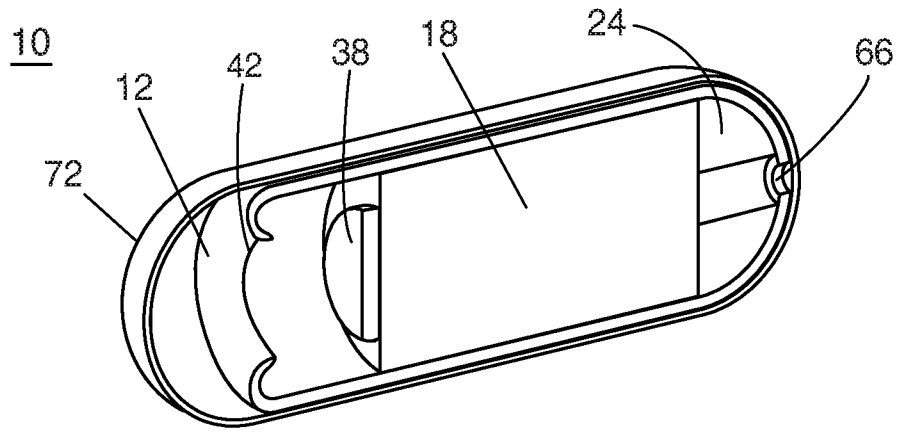

FIG. 13

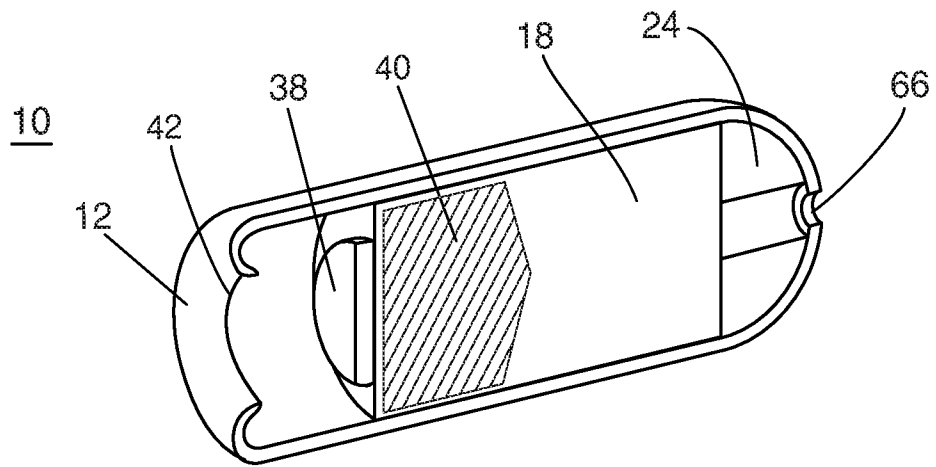

FIG. 14

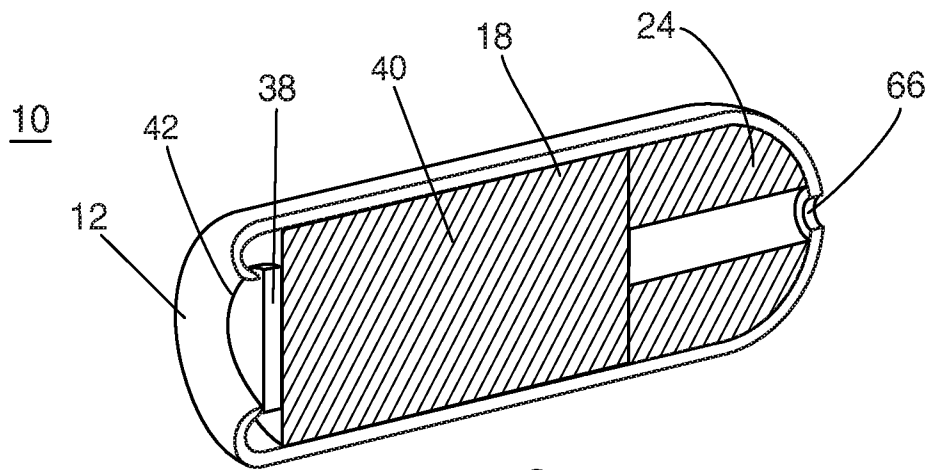

FIG. 15

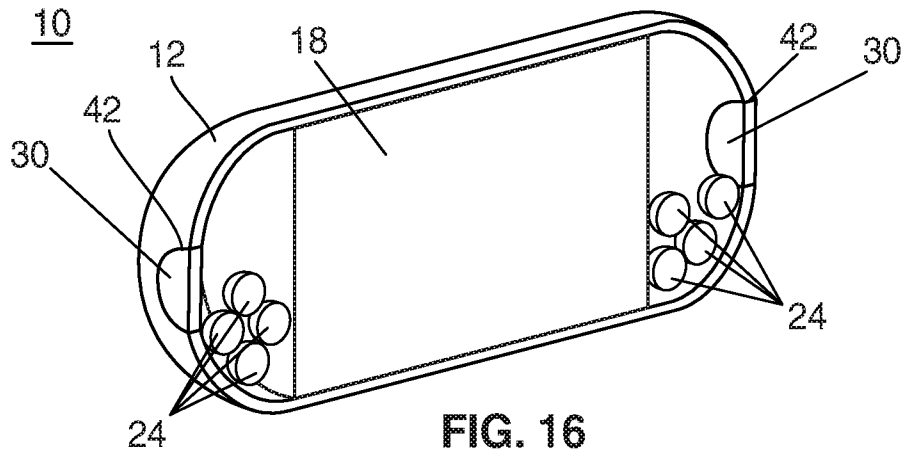

FIG. 16

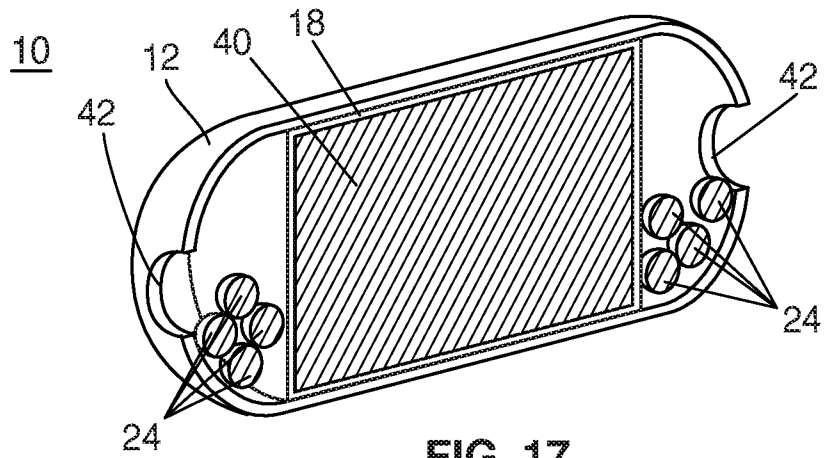

FIG. 17

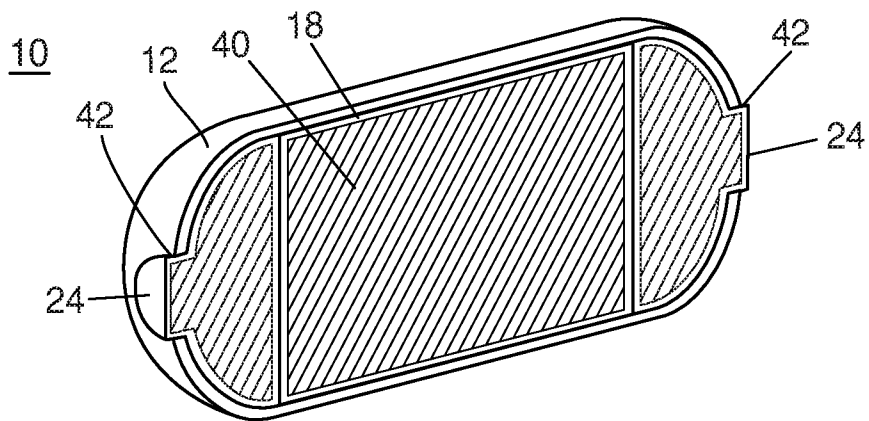

FIG. 18

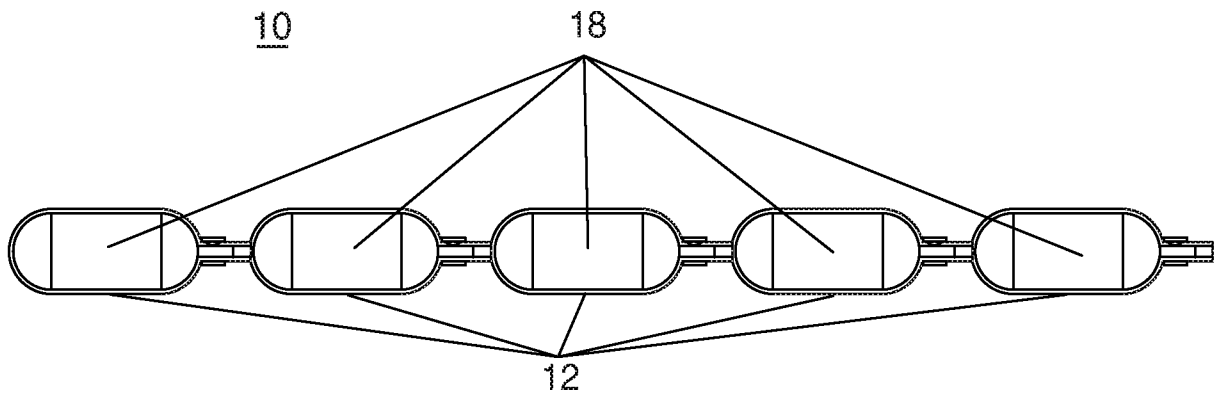

FIG. 19

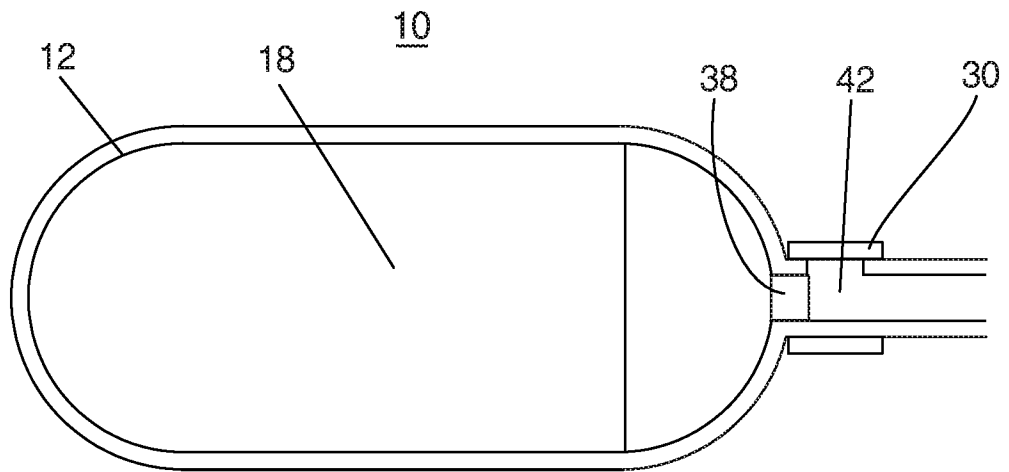

FIG. 20

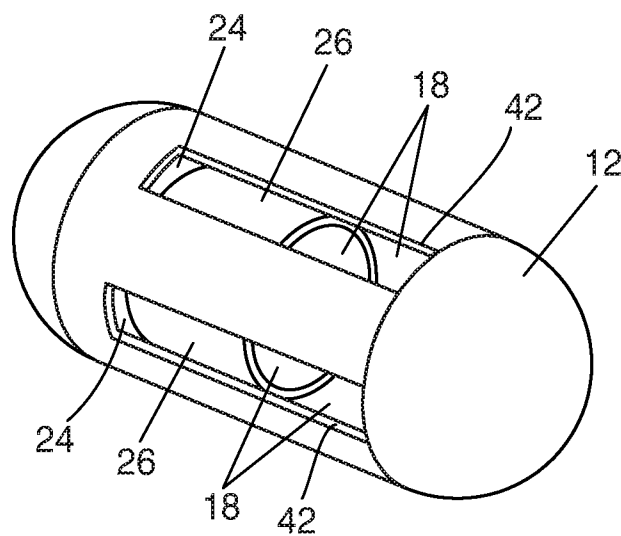

FIG. 21

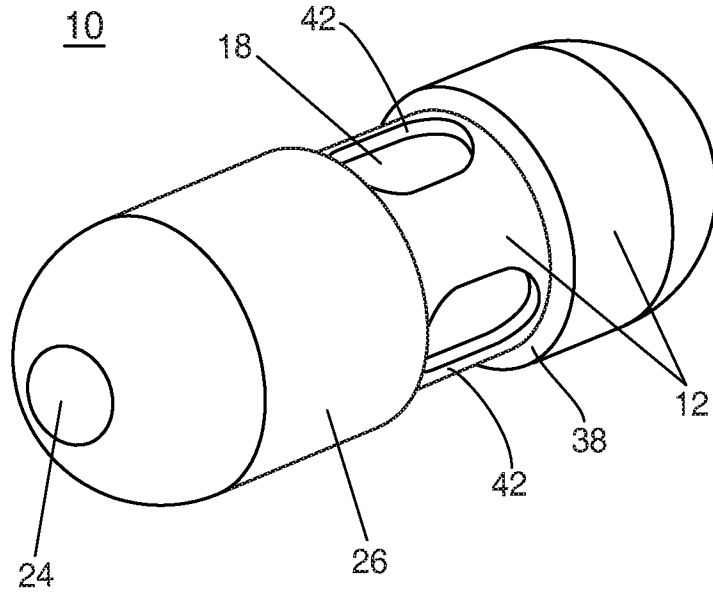

FIG. 22

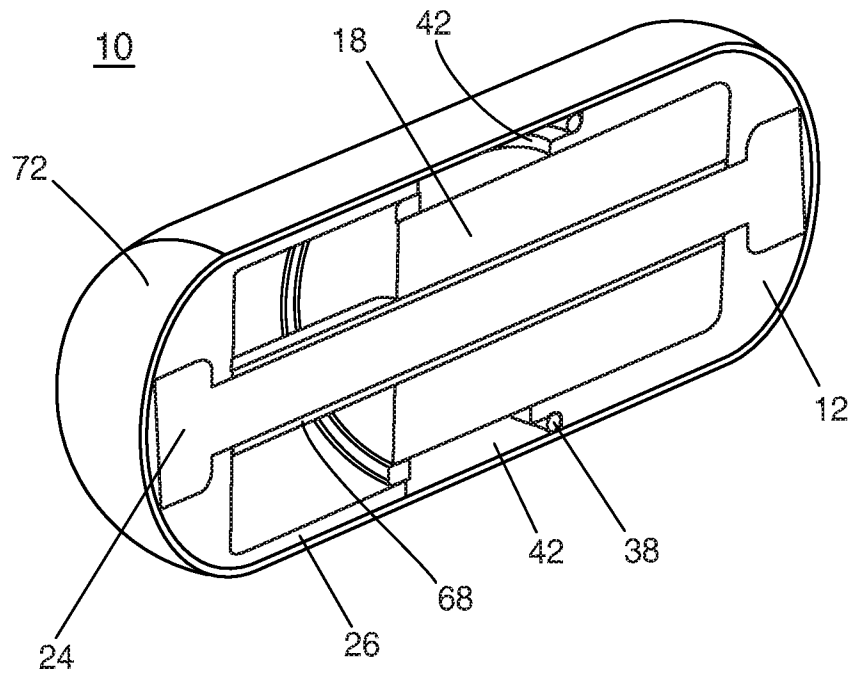

FIG. 23

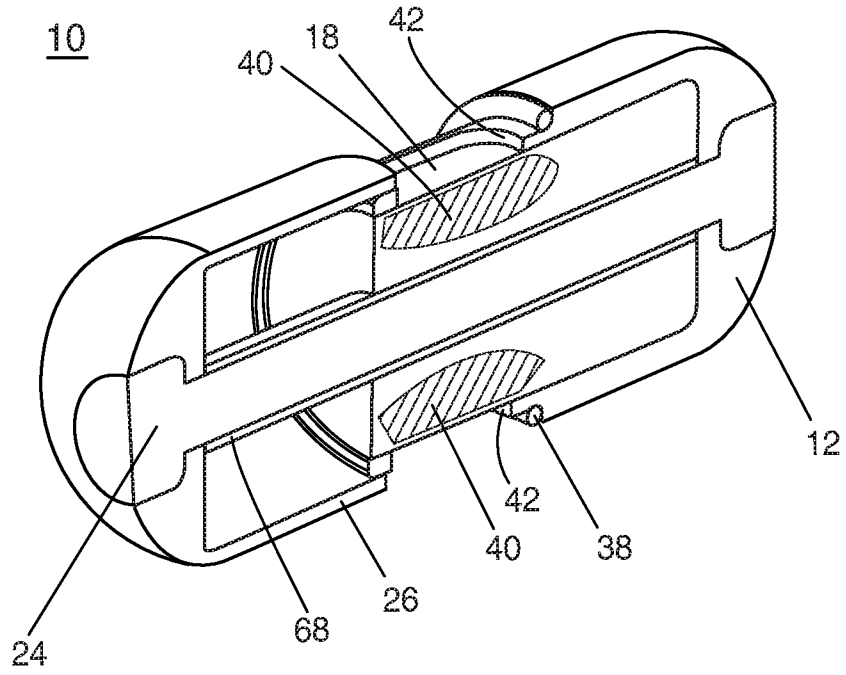

FIG. 24

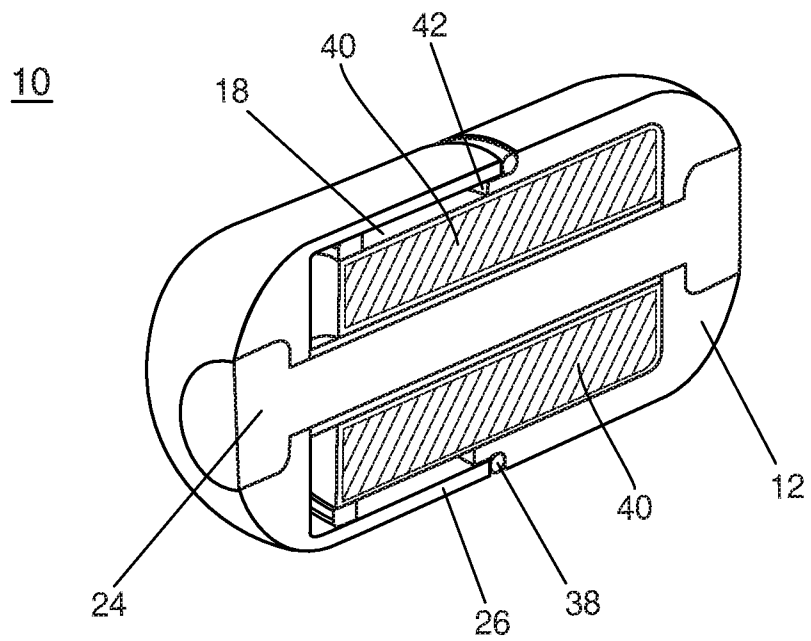

FIG. 25

12 / 18

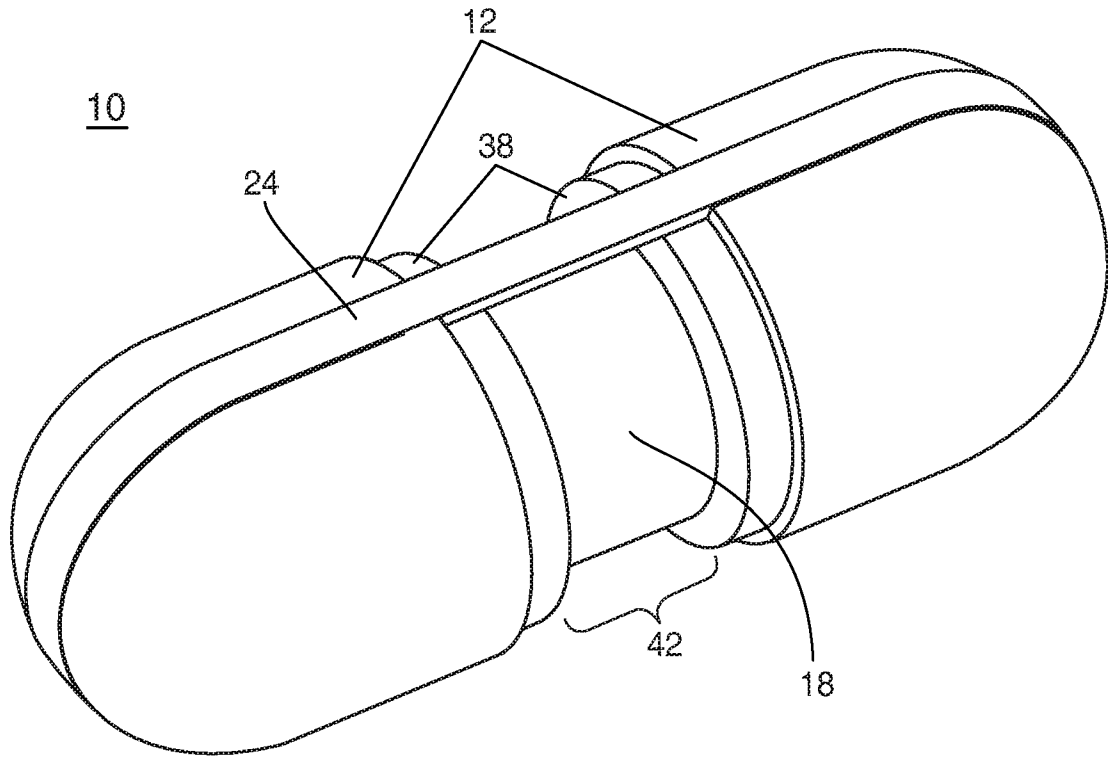

FIG. 26

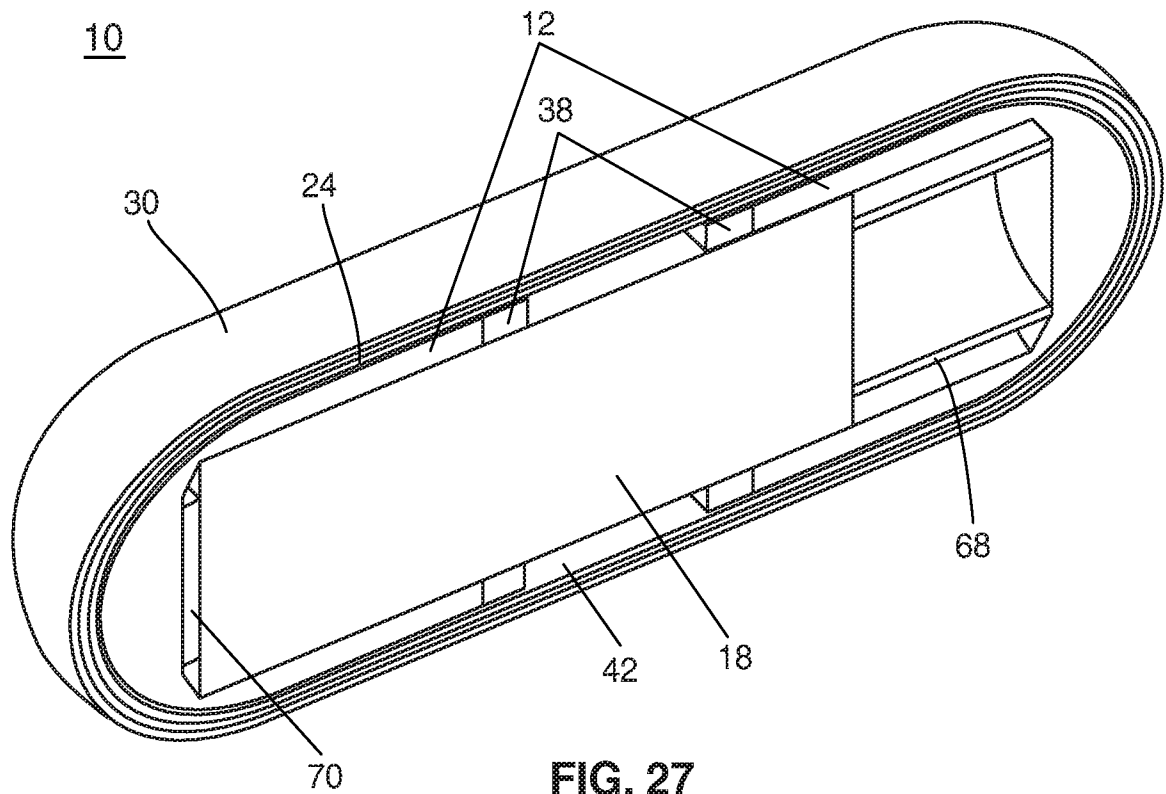

FIG. 27

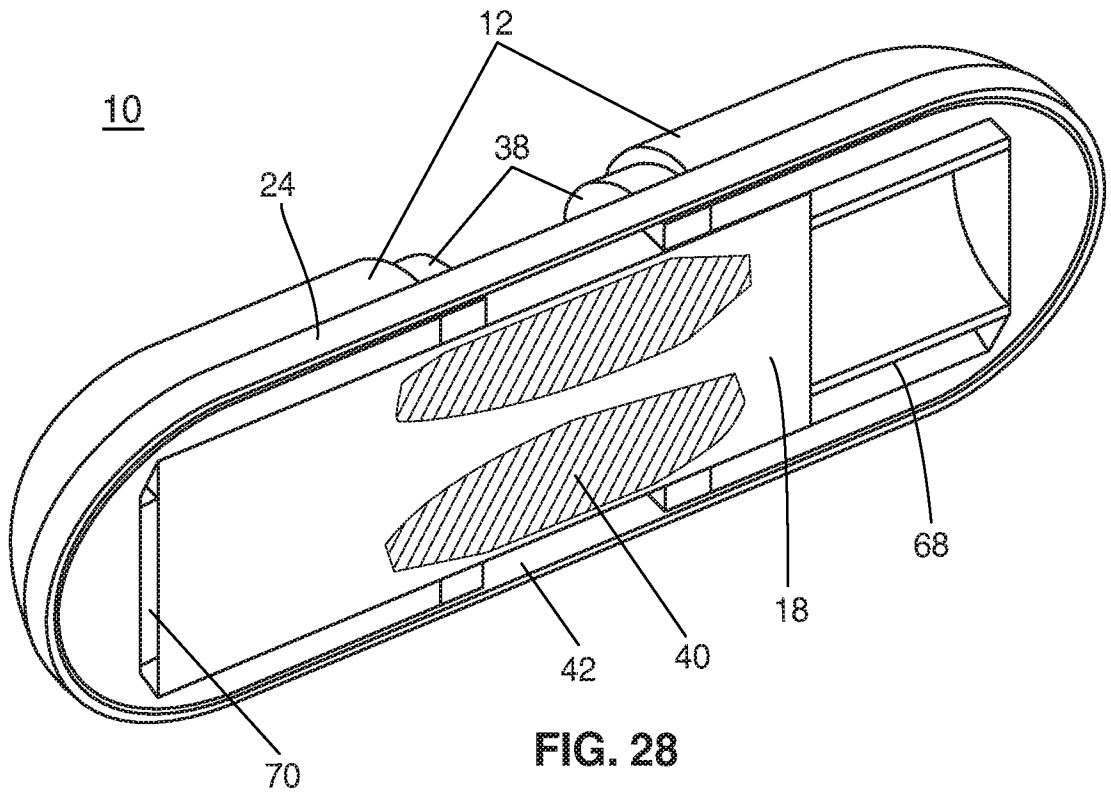

FIG. 28

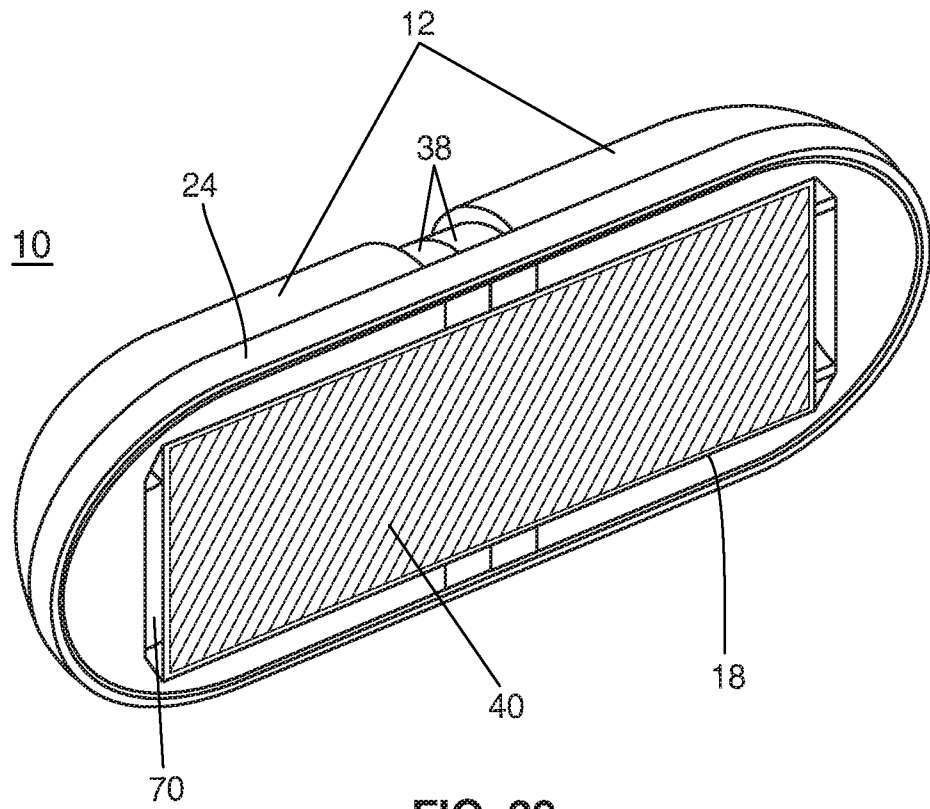
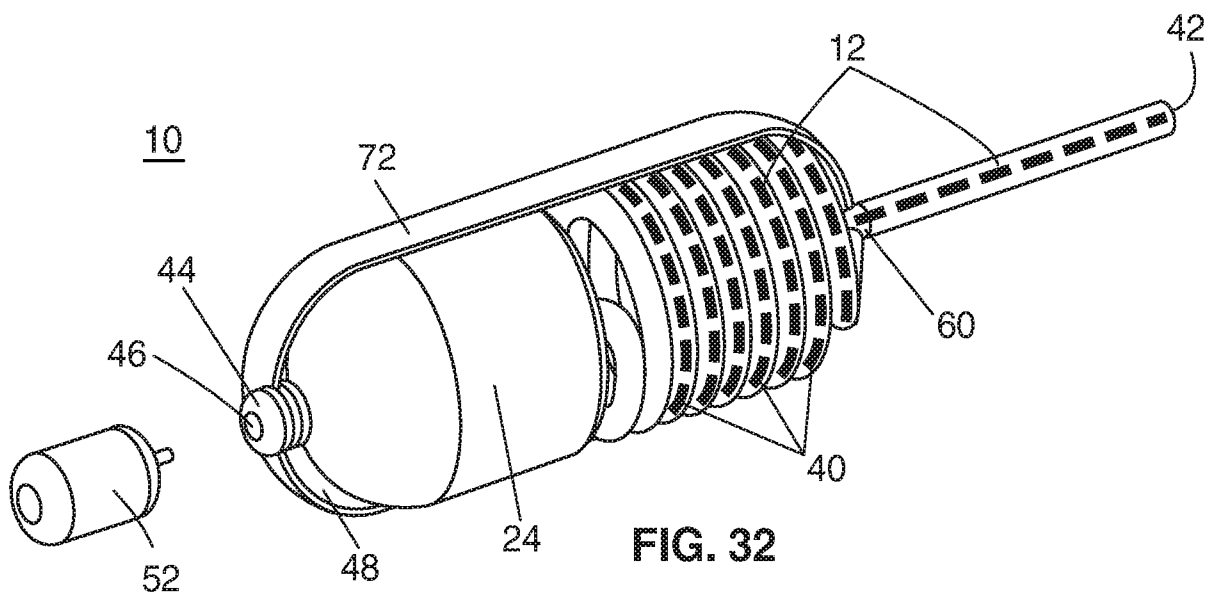
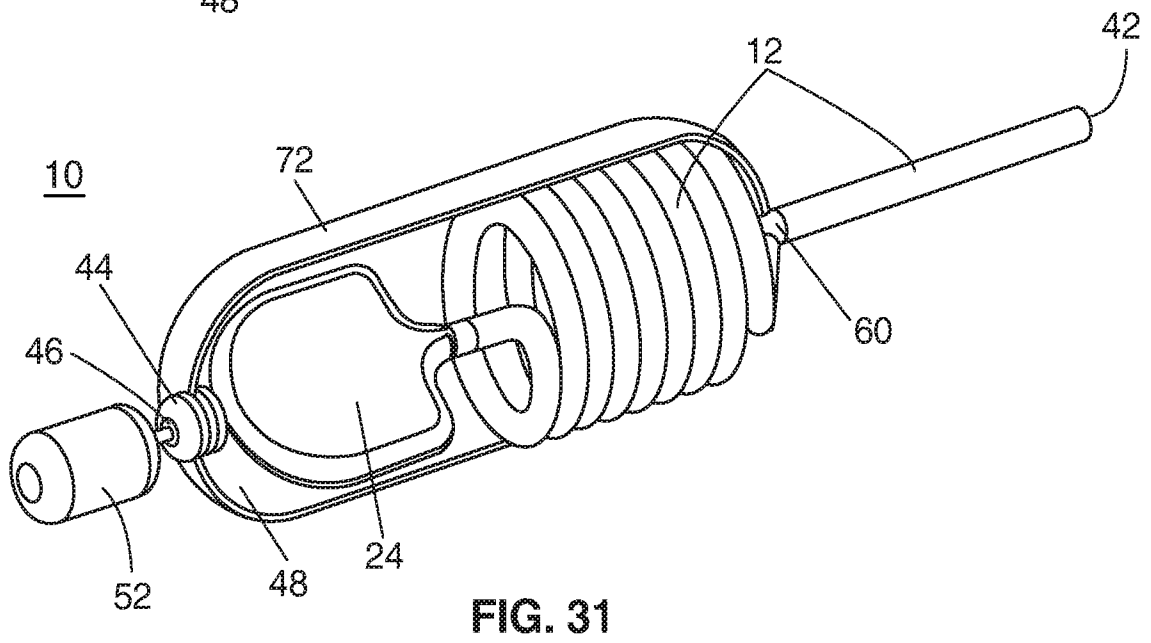
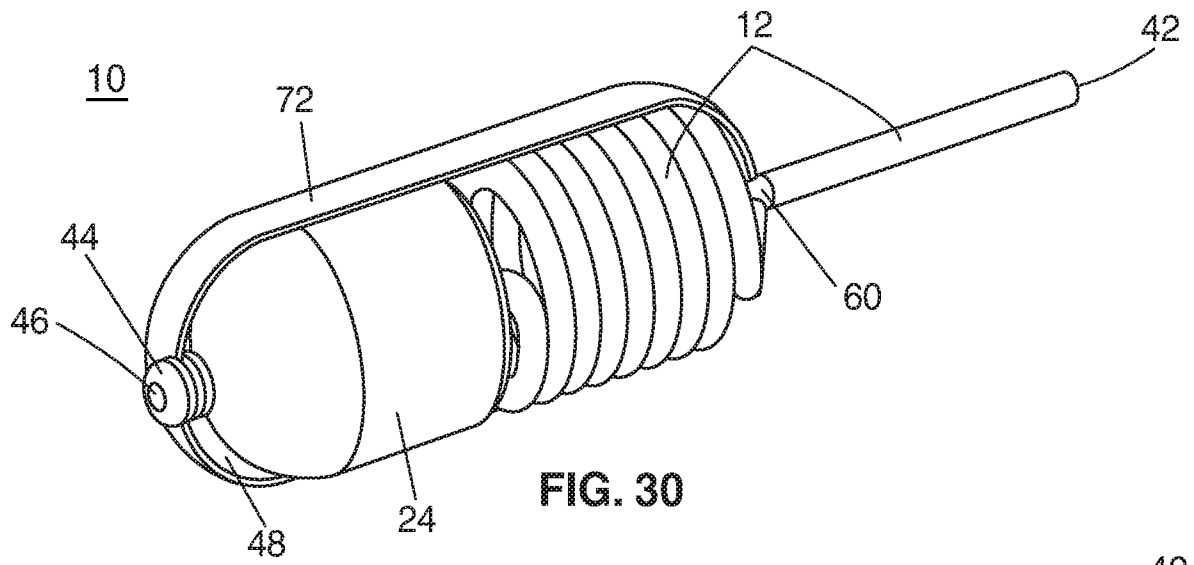

FIG. 29



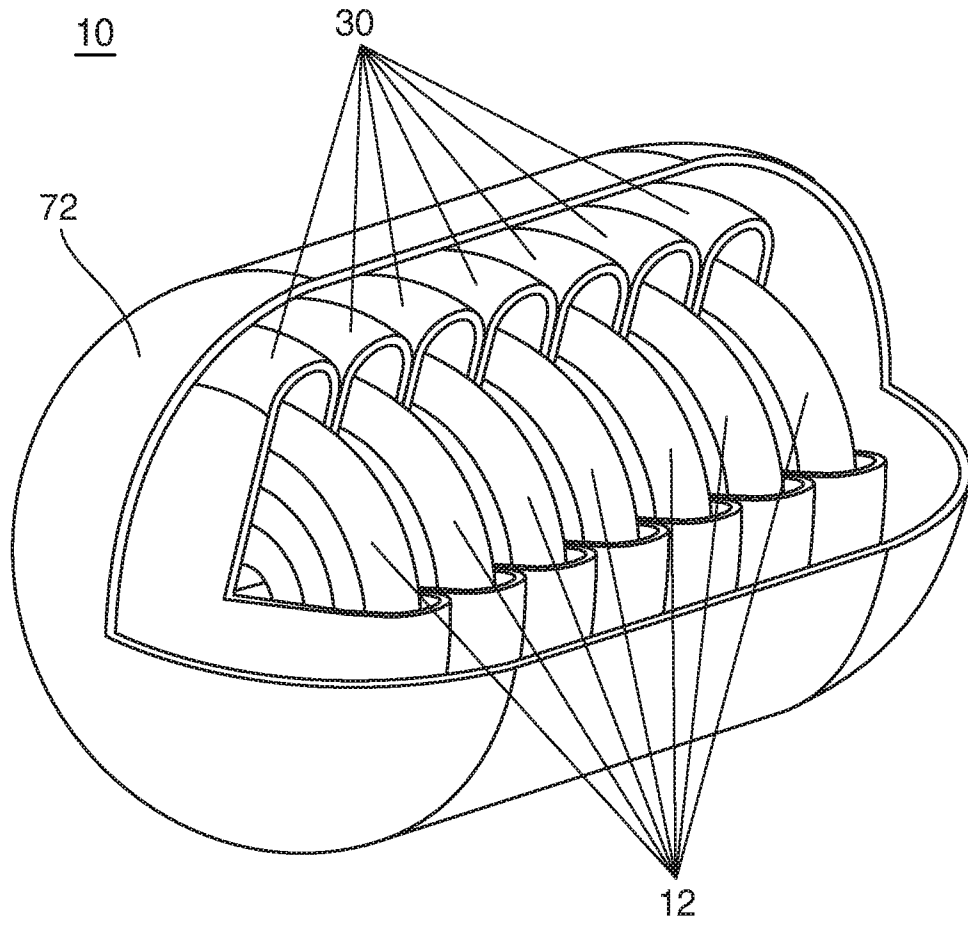

FIG. 33

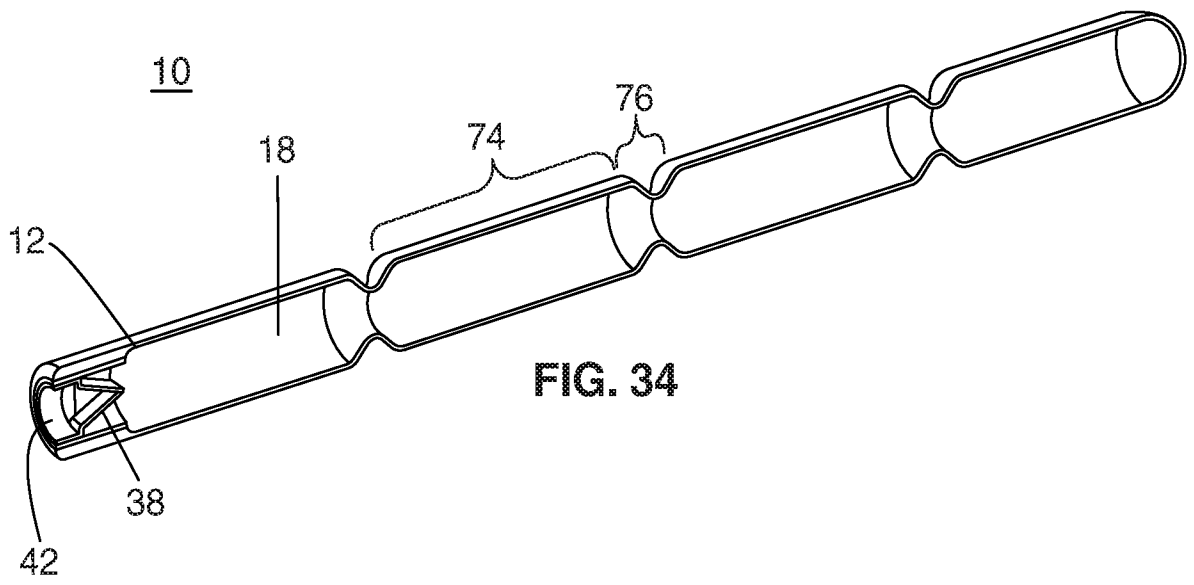

FIG. 34

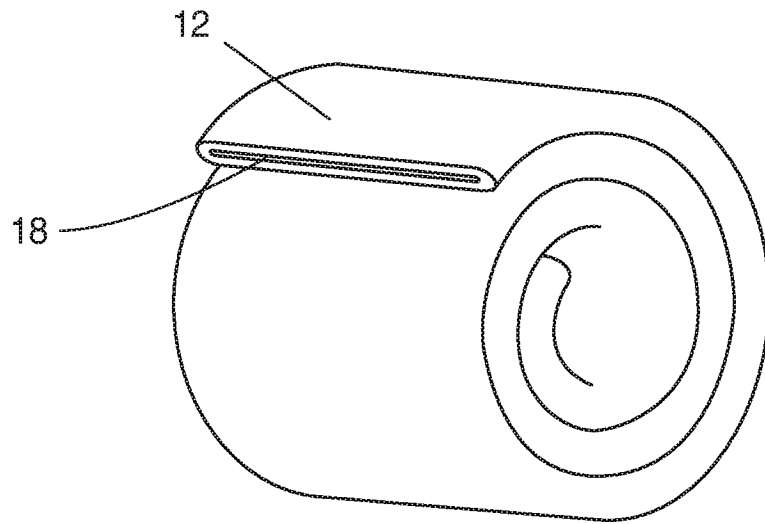

FIG. 35

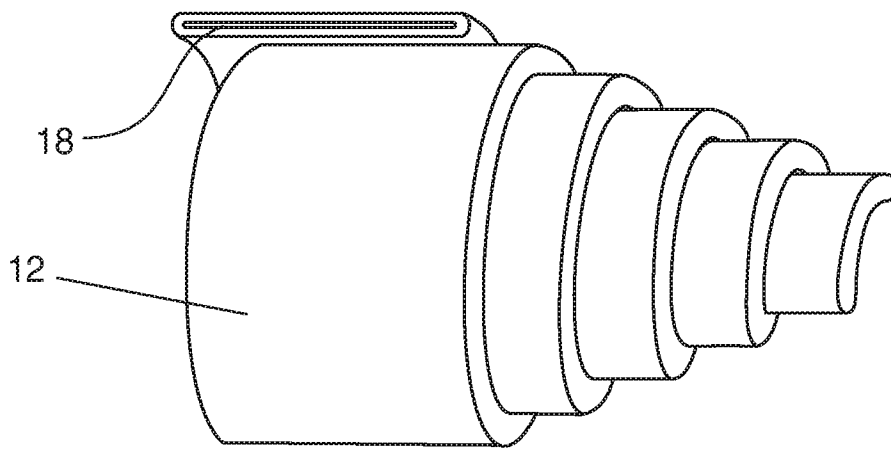

FIG. 36

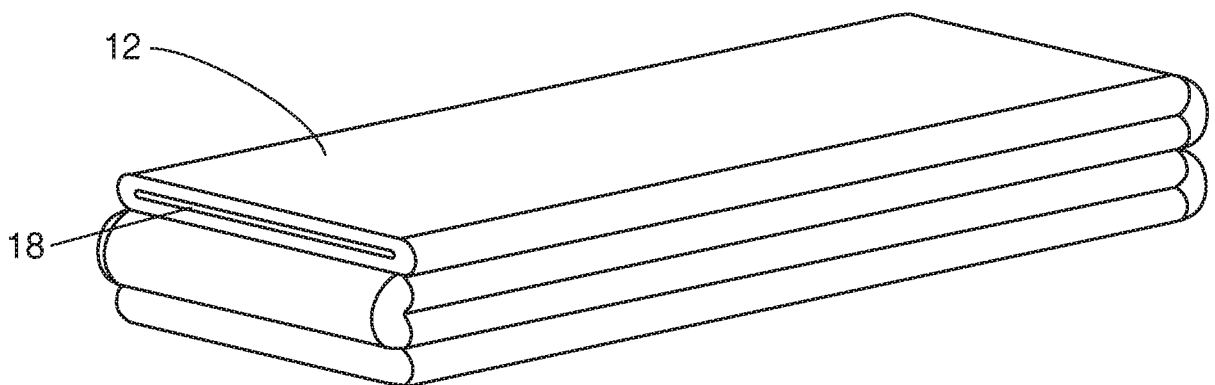

FIG. 37

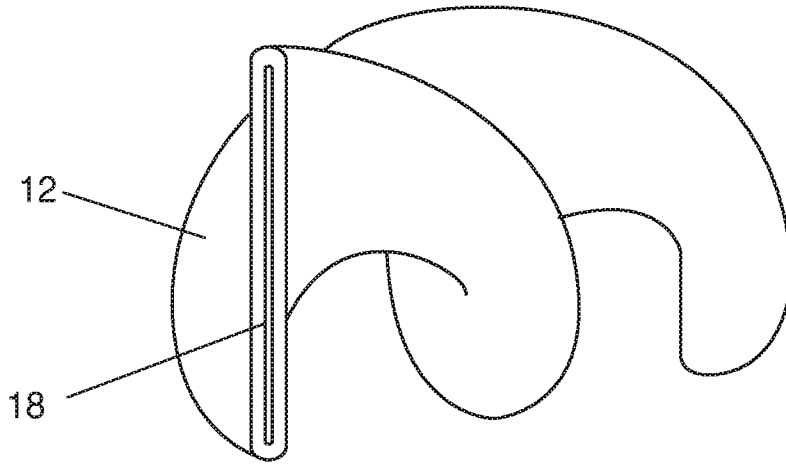

FIG. 38

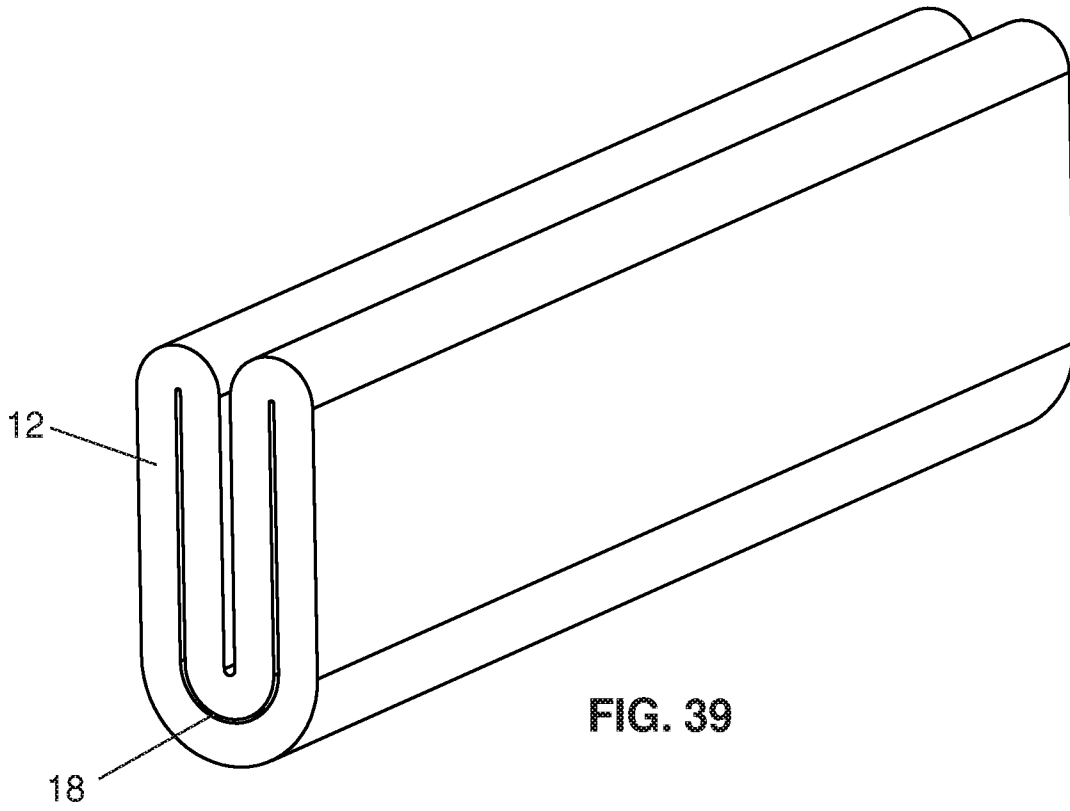

FIG. 39

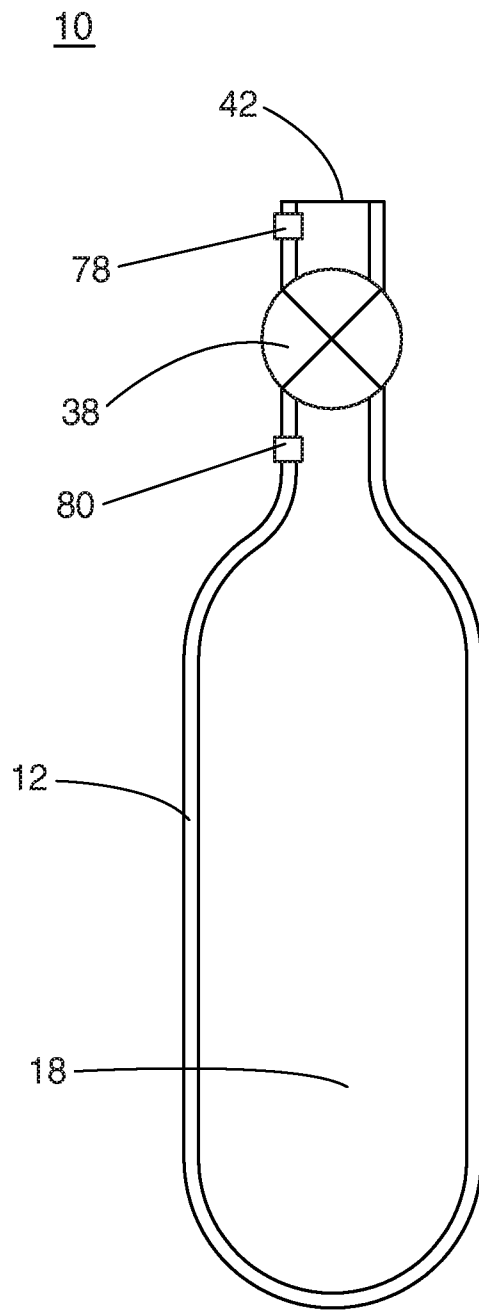

FIG. 40

INTERNATIONAL SEARCH REPORT

International application No.

PCT/US 18/33434

A. CLASSIFICATION OF SUBJECT MATTER IPC(8) - A61B 10/00; A61B 10/02 (2018.01) CPC - A61B 10/00; A61B 10/02; A61B 2010/0061; A61B 10/0045		
According to International Patent Classification (IPC) or to both national classification and IPC		
B. FIELDS SEARCHED		
Minimum documentation searched (classification system followed by classification symbols) See Search History Document		
Documentation searched other than minimum documentation to the extent that such documents are included in the fields searched See Search History Document		
Electronic data base consulted during the international search (name of data base and, where practicable, search terms used) See Search History Document		
C. DOCUMENTS CONSIDERED TO BE RELEVANT		
Category*	Citation of document, with indication, where appropriate, of the relevant passages	Relevant to claim No.
X	US 7,037,275 B1 (MARSHALL et al.) 2 May 2006 (02.05.2006); entire document, especially col 4 in 55 to col 5 in 12, col 6 in 2-3, col 6 in 40-46, col 16 in 21-65, and Fig. 1-2 and 7.	1-7, 11-15, 22-24, 26-32, 39-40, 44, 46-50, 60-61, 63
--		--
Y		33-34
--		--
A		16-19, 36-38
X	US 4,481,952 A (PAWELEC) 13 November 1984 (13.11.1984); entire document, especially col 2 in 31-35, col 8 in 28-62, and Fig. 12-13.	1, 8-10, 20-21, 25, 35, 41-43, 45, 51-52, 54-59, 61-62, 64-69
--		--
Y		53
Y	US 2016/0038086 A1 (MARS, INCORPORATED) 11 February 2016 (11.02.2016); especially para [0001], [0050]-[0058], and Fig. 1A.	33-34
Y	US 2011/0060189 A1 (BELSON) 10 March 2011 (10.03.2011); entire document, especially para [0235], and Fig. 10.	53
A	US 3,528,429 A (BEAL et al.) 15 September 1970 (15.09.1970); entire document, especially Abstract, col 2, in 57-60, col 3, in 21-59 and Fig. 1-5.	16-19, 36-38
A	US 2007/0173738 A1 (STOLTZ) 26 July 2007 (26.07.2007); entire document.	1-69
A	US 2011/0208011 A1 (BEN-HORIN) 25 August 2011 (25.08.2011); entire document.	1-69
<input checked="" type="checkbox"/> Further documents are listed in the continuation of Box C. <input type="checkbox"/> See patent family annex.		
* Special categories of cited documents: "A" document defining the general state of the art which is not considered to be of particular relevance "E" earlier application or patent but published on or after the international filing date "L" document which may throw doubts on priority claim(s) or which is cited to establish the publication date of another citation or other special reason (as specified) "O" document referring to an oral disclosure, use, exhibition or other means "P" document published prior to the international filing date but later than the priority date claimed "T" later document published after the international filing date or priority date and not in conflict with the application but cited to understand the principle or theory underlying the invention "X" document of particular relevance; the claimed invention cannot be considered novel or cannot be considered to involve an inventive step when the document is taken alone "Y" document of particular relevance; the claimed invention cannot be considered to involve an inventive step when the document is combined with one or more other such documents, such combination being obvious to a person skilled in the art "&" document member of the same patent family		
Date of the actual completion of the international search 26 September 2018	Date of mailing of the international search report 22 OCT 2018	
Name and mailing address of the ISA/US Mail Stop PCT, Attn: ISA/US, Commissioner for Patents P.O. Box 1450, Alexandria, Virginia 22313-1450 Facsimile No. 571-273-8300	Authorized officer: Lee W. Young PCT Helpdesk: 571-272-4300 PCT OSP: 571-272-7774	

INTERNATIONAL SEARCH REPORT

International application No.

PCT/US 18/33434

Box No. II Observations where certain claims were found unsearchable (Continuation of item 2 of first sheet)

This international search report has not been established in respect of certain claims under Article 17(2)(a) for the following reasons:

- 1. Claims Nos.:
because they relate to subject matter not required to be searched by this Authority, namely:

- 2. Claims Nos.:
because they relate to parts of the international application that do not comply with the prescribed requirements to such an extent that no meaningful international search can be carried out, specifically:

- 3. Claims Nos.:
because they are dependent claims and are not drafted in accordance with the second and third sentences of Rule 6.4(a).

Box No. III Observations where unity of invention is lacking (Continuation of item 3 of first sheet)

This International Searching Authority found multiple inventions in this international application, as follows:
This application contains the following inventions which are not so linked as to form a single general inventive concept under PCT Rule 13.1. In order for all inventions to be examined, the appropriate additional examination fees must be paid.

Group I: Claims 1-69 directed to a device for collecting gastrointestinal samples having a capsule and a tube-shaped body.

Group II: Claims 70-77 directed to a device for collecting gastrointestinal samples having a body, a opening on a sidewall of the body, a plurality of plates, and an actuator.

Group III: Claims 78-83 directed to a device for collecting gastrointestinal samples having an outer body, a covering element, an opening in a sidewall of the outer body, a hollow piston, and an actuator.

-*- See Supplemental Box -*-

- 1. As all required additional search fees were timely paid by the applicant, this international search report covers all searchable claims.
- 2. As all searchable claims could be searched without effort justifying additional fees, this Authority did not invite payment of additional fees.
- 3. As only some of the required additional search fees were timely paid by the applicant, this international search report covers only those claims for which fees were paid, specifically claims Nos.:

- 4. No required additional search fees were timely paid by the applicant. Consequently, this international search report is restricted to the invention first mentioned in the claims; it is covered by claims Nos.:
1-69

Remark on Protest

- The additional search fees were accompanied by the applicant's protest and, where applicable, the payment of a protest fee.
- The additional search fees were accompanied by the applicant's protest but the applicable protest fee was not paid within the time limit specified in the invitation.
- No protest accompanied the payment of additional search fees.

INTERNATIONAL SEARCH REPORT

International application No.

PCT/US 18/33434

-. Box III.0 - Explanations where unity of invention is lacking -.

Group IV: Claims 84-100 directed to a device for collecting gastrointestinal samples having a body, a collecting member, an opening, a sealing element, and an actuator.

Group V: Claims 101-109 directed to a device for collecting gastrointestinal samples having a body, an opening, an external pH sensitive degradable covering element, and an internal pH sensitive degradable covering element.

Group VI: Claims 110-116 directed to a system for collecting gastrointestinal samples having a first capsule, a second capsule, and a third capsule.

Group VII: Claims 117-131 directed to a system of collecting gastrointestinal samples having a capsule and a plurality of collecting members.

The inventions listed as Groups I-VII do not relate to a single general inventive concept under PCT Rule 13.1 because, under PCT Rule 13.2, they lack the same or corresponding special technical features for the following reasons:

SPECIAL TECHNICAL FEATURES

The invention of Group I includes the special technical feature of a tube-shaped body wound, twisted or folded within said capsule, not required by the claims of Group II-VII.

The invention of Group II includes the special technical feature of a plurality of plates mounted along a spindle running along a longitudinal axis of the body, adjacent plates comprising a space between them, not required by the claims of Group I or III-VII.

The invention of Group III includes the special technical feature of a hollow piston shaped to mate to an inner surface of the outer body, the piston positioned at an end of the body, not required by the claims of Group I-II or IV-VII.

The invention of Group IV includes the special technical feature of a sealing element movable from a first position where the opening is open to a second position where the opening is sealed by the sealing element, not required by the claims of Group I-III or V-VII.

The invention of Group V includes the special technical feature of an external pH sensitive degradable covering element covering the opening; and an internal pH sensitive degradable covering element covering the opening, not required by the claims of Group I-IV or VI-VII.

The invention of Group VI includes the special technical feature of a second small intestine targeting capsule; and a third colon targeting capsule, not required by the claims of Group I-V or VII.

The invention of Group VII includes the special technical feature of a plurality of collecting members each comprising a hollow body within the capsule and a degradable covering element, the collecting members linked together by connecting members to form a chain, not required by the claims of Group I-VI.

COMMON TECHNICAL FEATURES

Groups I-VII share the common technical feature of a device for collecting gastrointestinal samples. However, this shared technical feature does not represent a contribution over prior art as being anticipated by US 3,315,660 A (ABELLA) (hereinafter Abella), which teaches a device for collecting gastrointestinal samples (1; Fig. 1-2; col 3 ln 1-9)

Groups I and VI-VII share the common technical feature of a system for collecting gastrointestinal samples comprising a capsule. However, this shared technical feature does not represent a contribution over prior art as being anticipated by Abella, which teaches a system for collecting gastrointestinal samples (1; Fig. 1-2; col 3 ln 1-9) comprising a capsule (1; Fig. 1).

Groups II-V share the common technical feature of a device for collecting gastrointestinal samples, comprising a body, and an opening in fluid communication with the body. However, this shared technical feature does not represent a contribution over prior art as being anticipated by Abella, which teaches a device for collecting gastrointestinal samples (1; Fig. 1; col 3 ln 1-9), comprising a body (outer body of 1; Fig. 1-2), and an opening in fluid communication with the body (4; Fig. 1-2; col 3 ln 1-41).

Groups II-IV share the common technical feature of a device for collecting gastrointestinal samples, comprising a body, an opening on the body, and actuator configured to induce movement. However, this shared technical feature does not represent a contribution over prior art as being anticipated by Abella, which teaches a device for collecting gastrointestinal samples (1; Fig. 1; col 3 ln 1-9), comprising a body (outer body of 1; Fig. 1-2), an opening on the body (4; Fig. 1-2; col 3 ln 1-41), and actuator configured to induce movement (10; Fig. 1; col 53-71).

As the common technical features were known in the art at the time of the invention, these cannot be considered special technical features that would otherwise unify the groups.

Therefore, Groups I-VII lack unity under PCT Rule 13 because they do not share a same or corresponding special technical feature.

INTERNATIONAL SEARCH REPORT

International application No.
PCT/US 18/33434

C (Continuation). DOCUMENTS CONSIDERED TO BE RELEVANT		
Category*	Citation of document, with indication, where appropriate, of the relevant passages	Relevant to claim No.
A	US 5,738,110 A (BEAL et al.) 14 April 1998 (14.04.1998); entire document.	1-69