

(19) World Intellectual Property Organization
International Bureau



(43) International Publication Date
30 May 2002 (30.05.2002)

PCT

(10) International Publication Number
WO 02/43148 A2

- (51) International Patent Classification⁷: **H01L 27/00**
- (21) International Application Number: PCT/US01/43555
- (22) International Filing Date:
20 November 2001 (20.11.2001)
- (25) Filing Language: English
- (26) Publication Language: English
- (30) Priority Data:
60/252,714 22 November 2000 (22.11.2000) US
- (71) Applicant: **CARNEGIE MELLON UNIVERSITY**
[US/US]; 5000 Forbes Avenue, Pittsburgh, PA 15213 (US).
- (72) Inventors: **FEDDER, Gary, K.**; 110 George Street, Turtle Creek, PA 15145 (US). **LAKDAWALA, Hasnain**; 490 South Highland Avenue, #310, Pittsburgh, PA 15206 (US).
- (74) Agents: **KNEDEISEN, Mark, G.** et al.; Kirkpatrick & Lockhart LLP, Henry W. Oliver Building, 535 Smithfield Street, Pittsburgh, PA 15222-2312 (US).
- (81) Designated States (*national*): AE, AG, AL, AM, AT, AU, AZ, BA, BB, BG, BR, BY, BZ, CA, CH, CN, CO, CR, CU, CZ, DE, DK, DM, DZ, EC, EE, ES, FI, GB, GD, GE, GH, GM, HR, HU, ID, IL, IN, IS, JP, KE, KG, KP, KR, KZ, LC, LK, LR, LS, LT, LU, LV, MA, MD, MG, MK, MN, MW, MX, MZ, NO, NZ, PL, PT, RO, RU, SD, SE, SG, SI, SK, SL, TJ, TM, TR, TT, TZ, UA, UG, UZ, VN, YU, ZA, ZW.
- (84) Designated States (*regional*): ARIPO patent (GH, GM, KE, LS, MW, MZ, SD, SL, SZ, TZ, UG, ZM, ZW), Eurasian patent (AM, AZ, BY, KG, KZ, MD, RU, TJ, TM), European patent (AT, BE, CH, CY, DE, DK, ES, FI, FR, GB, GR, IE, IT, LU, MC, NL, PT, SE, TR), OAPI patent (BF, BJ, CF, CG, CI, CM, GA, GN, GQ, GW, ML, MR, NE, SN, TD, TG).

[Continued on next page]

(54) Title: MICROMACHINED INFRARED SENSITIVE PIXEL AND INFRARED IMAGER INCLUDING SAME

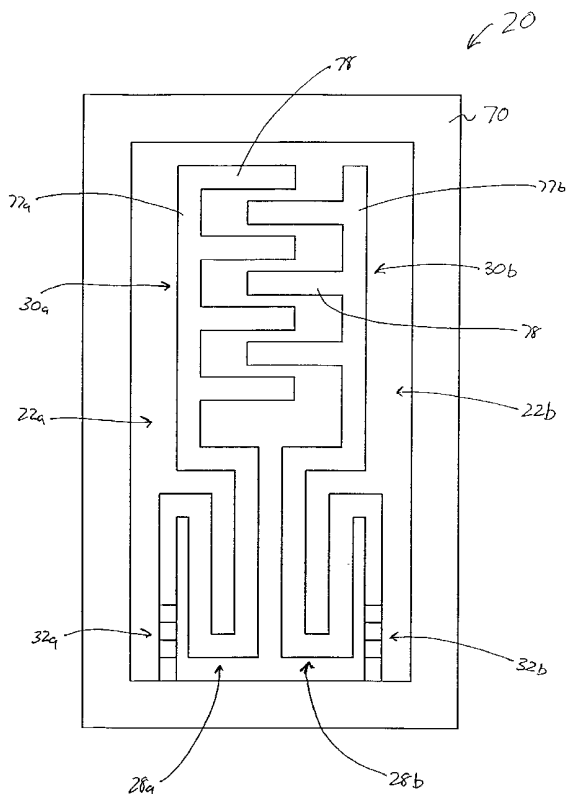

(57) Abstract: An infrared (IR) sensitive pixel (20) and an IR imager (100) including the same. According to one embodiment, the pixel includes a substrate assembly (24) having a cavity (26) defined by at least one sidewall (33) and a cantilevered beam (22) connected to the substrate assembly and disposed in the cavity. The cantilevered beam includes a first spring portion (28) and a first capacitor plate portion (30), wherein the first spring portion includes at least two materials having different coefficients of thermal expansion. The pixel further includes a second capacitor plate portion (30, 34), such that incident IR radiation causes the first spring portion of the cantilevered beam to move laterally relative to the sidewall, thereby creating a variable capacitance between the first capacitor plate portion of the cantilevered beam and the second capacitor plate portion.



WO 02/43148 A2



Published:

— *without international search report and to be republished upon receipt of that report*

For two-letter codes and other abbreviations, refer to the "Guidance Notes on Codes and Abbreviations" appearing at the beginning of each regular issue of the PCT Gazette.

5 MICROMACHINED INFRARED SENSITIVE PIXEL AND INFRARED IMAGER
INCLUDING SAME

CROSS-REFERENCE TO RELATED APPLICATIONS

10 This application claims priority to U.S. provisional patent application Serial No. 60/252,714, filed November 22, 2000, which is incorporated herein by reference.

STATEMENT REGARDING FEDERALLY SPONSORED RESEARCH AND
DEVELOPMENT

15 This research was funded in part by the U. S. Government. The U. S. Government may have certain rights in any patent awarded as provided by Grant No. F30602-97-2-0323, awarded in 1997 and Grant No. F30602-99-2-0545, awarded in 1999 by the Defense Advanced Research Projects Agency (DARPA).

20 BACKGROUND OF INVENTION

Field of Invention

The present invention relates generally to micromachining and, more particularly, to a micromachined infrared sensitive pixel that may be used in, for example, an infrared imager.

25

Description of the Background

The human eye can only gather information from the visible light region of the electromagnetic spectrum. Imaging in the infrared (IR) region of the spectrum, however, allows sensing of small differences in temperature in the environment. This ability is highly
30 useful for surveillance and security applications as it enables detection of objects in absolute

darkness. Conventional IR imagers have been in use by law enforcement and military agencies. However, conventional IR imager technology relies on semiconductor sensors, which are expensive and bulky due to the necessary cooling to liquid nitrogen temperatures (77 K). Newer uncooled imagers are based on custom materials and are expensive to
5 fabricate.

The applications for low cost infrared imagers range from household security applications to "night vision" aids for night driving. IR sensors with high enough sensitivity (0.1 degree Kelvin) to be suitable for imaging purposes are expensive. Imagers made using conventional semiconductor technologies are very expensive and bulky, as the imagers have
10 to be cooled to the temperature of liquid nitrogen. Newer uncooled imagers are based on custom processes that are expensive to fabricate.

Several research and development groups have created medium-performance IR imaging arrays. One example is the Honeywell uncooled bolometer array. Certain technology spearheaded by Sarnoff Laboratories and Sarcon Microsystems includes the
15 creation of suspended bimorph micro-plates whose thermo-mechanical displacement is detected by measuring the capacitance of the micro-plate to the substrate. The main drawback of that approach is that the designs are difficult to manufacture due to the good control of residual stress.

Other approaches to uncooled IR imagers include the Texas Instrument Approach:
20 An array of $25\mu\text{m} - 75\mu\text{m}$ Barium Strontium Titanate (BST) detectors whose polarization and electric constant change with temperature, resulting in a change in capacitor charge as the scene temperature varies. This technology is limited by the ability to obtain good quality, very thin BST films. The best reported Noise Equivalent Difference Temperature (NEDT) for the system was 100mK (C. Hanson, "Uncooled thermal imaging at Texas
25 Instruments," SPIE vol. 2020, Infrared Technology XIX (1993)).

An approach by Honeywell uses an array of micro-bolometers with Vanadium Oxide (VO_x) resistors (Temperature Coefficient of Resistance (TCR) 2%/K). The bolometer is suspended by a silicon nitride bridge for thermal isolation from the substrate containing the read out electronics. The commercial products achieve a Noise Equivalent
30 Difference Temperature (NEDT) in the range of 100mK and have been integrated in video

rate and single shot digital cameras. Recent results from Raytheon have reported a 20mK NEDT for a $2500\mu\text{m}^2$ pixel size. This approach is limited by the self-heating of the pixel and 1/f noise. (B.E. Cole et al., "Monolithic Two-Dimensional Arrays of Micromachined Microstructures for Infrared Applications," *Proceedings of the IEEE*, Vol. 86, no. 8, pp. 1679-1686, 1998, and W. Radford et al., "Microbolometer Uncooled Infrared Camera with 20mK NEDT," *SPIE Conference on IR Tech. and Applications XXIV*, San Diego, CA, July 1998, pp.636-646.

5 An approach by Sarnoff Research Center senses capacitance change of a bimetallic element with the substrate. The thermal isolation is designed using a SiC suspension and the bimetallic strip includes SiC and Aluminum. The theoretical value for the NEDT using this technology is 5mK.

Silicon infrared imagers developed at the University of Michigan use a n+ polysilicon and gold thermocouple to measure the temperature difference between the pixel and the substrate. The best reported NEDT for a $200\mu\text{m}$ by $650\mu\text{m}$ device was 200mK. These devices have been integrated into a standard CMOS process to achieve a NEDT of 15 320mK for a $250\mu\text{m}$ by $250\mu\text{m}$ device. It is difficult to achieve small pixel size with this approach due to the larger number of conductors in the thermopile that increase the pixel thermal conductivity to the substrate.

Heat balancing CMOS imagers also developed at the University of Michigan use 20 suspended CMOS transistors that are heat balanced to cancel out the incident infrared radiation. The group fabricated a $100\mu\text{m}$ x $100\mu\text{m}$ pixel and reported a detectivity of 3×10^7 $\text{cm} \cdot (\text{Hz})^{-1/2} / \text{W}$. The thermal isolation between the substrate and the pixel is poor due to the large number of conductors incident on the pixel. The approach is limited by the size of the pixel that cannot be reduced due to etching considerations.

25 Pyroelectric detectors using PVDF film deposited on CMOS have been demonstrated by Binne et al, "An integrated 16x16 PVDF pyroelectric sensor array," *IEEE Transactions on Ultrasonics, Ferroelectrics and Frequency Control*, vol. 47, Issue 6, Nov. 2000, pp. 1413-1420. The main drawback to this approach is that it requires an external mechanical chopper for operation.

A brief summary of the state of the art pixels demonstrated by industry and research groups is summarized in Table 1 below.

TABLE 1: Comparison of Pixel Performance Reported in Literature

5

	Honeywell	TI approach	Active Pixel	U. Mich	Pyroelectric
Principle	Bolometer	Ferroelectric	Heat-balancing	Thermopile	PVDF
Process	Custom	Custom	CMOS	CMOS	CMOS
Pixel size	50 μ m x 50 μ m	50 μ m x 50 μ m	100 μ m x 100 μ m	250 μ m x 250 μ m	105 μ m x 105 μ m
Bandwidth	30 Hz	30	30	NA	30 Hz
Noise Equivalent Power	30 x 10 ⁻¹² W/ \sqrt{Hz}	NA	300 x 10 ⁻¹² W/ \sqrt{Hz}	330 x 10 ⁻¹² W/ \sqrt{Hz}	2.4 x 10 ⁻¹¹ W/ \sqrt{Hz}
Detectivity (cm-(Hz) ^{-1/2} /W)	5 x 10 ⁸	NA	3 x 10 ⁷	7.7 x 10 ⁷	4.4 x 10 ⁸
NEDT	25mK	100mK	NA	320mK	NA

Accordingly, there is a need for a low cost imager that has the potential of being utilized in markets and applications that until now were not cost effective. For example, there is a need for an imager for applications such as night driving aids. IR closed circuit
10 cameras could aid surveillance and home security systems. Low cost IR imagers can be used to identify sources of heat leaks in homes and factories leading to energy savings.

SUMMARY OF THE INVENTION

According to one embodiment, the present invention is directed to a pixel for an IR
15 sensor. The pixel includes a substrate assembly having a cavity defined by at least one sidewall and a cantilevered beam connected to the substrate assembly and disposed in the cavity. The cantilevered beam includes a first spring portion and a first capacitor plate portion, wherein the first spring portion includes at least two materials having different coefficients of thermal expansion. The pixel further includes a second capacitor plate
20 portion, such that incident IR radiation causes the first spring portion of the cantilevered beam to move laterally relative to the sidewall, thereby creating a variable capacitance

between the first capacitor plate portion of the cantilevered beam and the second capacitor plate portion.

According to another embodiment, the pixel includes a substrate assembly, a first cantilevered beam and a second cantilevered beam. The substrate assembly includes a cavity defined by at least one sidewall. The first cantilevered beam is connected to the substrate assembly and disposed in the cavity, and includes a first spring portion and a first capacitor plate portion, wherein the first spring portion includes at least two materials having different coefficients of thermal expansion. The second cantilevered beam is also connected to the substrate assembly and disposed in the cavity, and includes a second spring portion and a second capacitor plate portion, wherein the second spring portion includes at least two materials having different coefficients of thermal expansion, such that incident IR radiation causes the first and second spring portions to move laterally relative to the sidewall thereby creating a variable capacitance between the first and second capacitor plate portions.

According to another embodiment, the present invention is directed to a micromachined structure. The micromachined structure includes a substrate assembly having a cavity defined by at least one sidewall. The micromachined structure also includes a first cantilevered beam connected to the substrate assembly and disposed in the cavity. The first cantilevered beam includes a first spring portion and a first capacitor plate portion, wherein the first spring portion includes at least two materials having different coefficients of thermal expansion. In addition, the micromachined structure includes a second capacitor plate portion, such that incident IR radiation causes the first spring portion of the first cantilevered beam to move laterally relative to the sidewall, thereby creating a variable capacitance between the first capacitor plate portion of the first cantilevered beam and the second capacitor plate portion.

According to another embodiment, the present invention is directed to an infrared (IR) imager including an addressing circuit and a pixel array coupled to the addressing circuit. The pixel array includes a plurality of IR sensitive pixels, wherein each pixel includes first and second cantilevered beams. The first cantilevered beam is connected to a substrate assembly and disposed in a cavity of the substrate assembly, wherein the cavity is

defined by a sidewall. The first cantilevered beam includes a first spring portion and a first capacitor plate portion, wherein the first spring portion includes at least two materials having different coefficients of thermal expansion. The second cantilevered beam is also connected to the substrate assembly and disposed in the cavity. The second cantilevered beam includes a second spring portion and a second capacitor plate portion, wherein the second spring portion includes at least two materials having different coefficients of thermal expansion, such that incident IR radiation causes the first and second spring portions to move laterally relative to the sidewall thereby creating a variable capacitance between the first and second capacitor plate portions.

10

BRIEF DESCRIPTION OF THE FIGURES

Embodiments of the present invention are described in conjunction with the following figures, wherein:

Figures 1 and 2 are diagrams illustrating a principle of operation according to one embodiment of the present invention;

Figure 3 is a top plan view of an infrared sensitive pixel according to one embodiment of the present invention;

Figure 4 is a cross-sectional side-view of the pixel of Fig. 3;

Figure 5 is a top plan view of an infrared sensitive pixel according to another embodiment of the present invention;

Figure 6 is a cross-sectional side-view of the pixel of Fig. 5;

Figures 7-9 illustrate a technique for fabricating an infrared sensitive pixel according to one embodiment of the present invention;

Figure 10 is a scanning electron micrograph (SEM) image of a pixel according to another embodiment of the present invention;

Figure 11 is a SEM image of a thermal isolation portion of the pixel of Figure 10;

Figure 12 is a cross-sectional side-view of the thermal isolation portion of Figure 11;

Figure 13 is a top plan view of a pixel according to another embodiment of the present invention;

Figure 14 is a side-view of a pixel according to another embodiment of the present

invention;

Figure 15 is a diagram of an infrared (IR) imager according to one embodiment of the present invention;

Figure 16 is a schematic diagram of an interface circuit of the IR imager of Figure 5 15 according to one embodiment of the present invention;

Figure 17 is a schematic diagram of the array of the IR imager of Figure 15 according to one embodiment of the present invention;

Figure 18 illustrates a clocking scheme for an IR imager according to one embodiment of the present invention; and

10 Figure 19 is a schematic diagram of the capacitance detection circuit of the IR imager of Figure 15 according to one embodiment of the present invention.

DETAILED DESCRIPTION OF THE INVENTION

According to one embodiment, the present invention is directed to a micromachined 15 infrared (IR) sensitive pixel. The operating principle of the IR pixel, according to one embodiment, is described in conjunction with Figures 1 and 2. Figure 1 illustrates two micromachined beams 10 anchored to a substrate assembly 12. The beams 10 may be, for example, CMOS micromachined beams having a cross-section along line C-C' in Figure 1 as illustrated in Figure 2. That is, the beams 10 may include both dielectric and metal 20 layers. As illustrated in Figure 2, the metal layers for the left-hand beam may be oriented on the right-hand side of the beam, and the metal layers for the right-hand beam may be oriented on the left-hand side of the beam.

The metal layers of the beams 10 may be, for example, aluminum such that the temperature coefficient of expansion (TCE) of the aluminum metal layers ($23 \times 10^{-6} \text{ K}^{-1}$) is 25 much greater than that of the CMOS inter-layer dielectric ($0.4 \times 10^{-6} \text{ K}^{-1}$). Thus, if a temperature change is induced in the beams due to incident IR energy (P_{in}), then a lateral bending moment is produced. The beam bending is proportional to a difference in the TCE of the metal layers and the inter-layer dielectric. The lateral motion increases the inter-beam separation and decreases the capacitance between the beams. This change in 30 capacitance may be measured by circuitry 14, such as an integrated CMOS capacitance-to-

voltage converter, which may output a voltage proportional to the power of the incident IR energy.

The lateral motion (δ) at the tip of a beam 10 of length L , width w , thickness t , and effective Young's Modulus E can be expressed as:

$$\delta = \frac{L^2}{2} \left(\frac{M_l}{EI_{zz}} \right) = \frac{6L^2 M_l}{Et w^3} \quad (1)$$

where M_l is the lateral bending due to the beam cross-section and I_{zz} is the moment of inertia

about the z axis expressed as $I_{zz} = \frac{1}{12} t w^3$. It should be noted that out-of-plane curl of the two beams 10 is substantially identical and does not contribute to performance degradation.

Figures 3 and 4 illustrate a micromachined IR sensitive pixel 20 according to one embodiment of the present invention. Figure 3 is a top plan view of the pixel 20 and Figure 4 is a cross-sectional view of the pixel 20 along line III-III'. As illustrated in these figures, the pixel 20 includes a cantilevered beam 22 connected to a substrate assembly 24 and disposed in a cavity 26 defined by the substrate assembly. According to one embodiment, the beam 22 may be a CMOS micromachined beam, i.e., a beam having dielectric (such as silicon dioxide) and metal (such as aluminum) layers fabricated according to CMOS processing techniques, such as a standard 0.5 μm 3-metal CMOS process.

As used herein, the term "cantilevered beam" is not limited to straight beams, but may also include, for example, meandering, serpentine or curved beams. In addition, the term "substrate assembly" as used herein refers to a substrate and any intervening layers or structures formed thereon or therein. The term "substrate" refers to a structure that is often the lowest layer of semiconductor material in a wafer or die, although in some technologies the substrate is not a semiconductor material.

The beam 22 may include, for example, a spring portion 28, a capacitive plate portion 30 and a thermal isolation portion 32. The spring portion 28 may include at least two materials having different temperature coefficients of expansion (TCE) aligned along the longitudinal axis of the beam 22. According to one embodiment, the spring portion 28 may be a CMOS micromachined structure having, for example, multiple aluminum layers and a silicon dioxide inter-layer dielectric aligned along the longitudinal axis of the beam

22. The TCE for aluminum is $23 \times 10^{-6} \text{ K}^{-1}$ and the TCE for silicon dioxide is $0.4 \times 10^{-6} \text{ K}^{-1}$. Thus, as explained previously, incident IR radiation impinging upon the spring portion 28 and capacitive plate portion 30 will cause the beam 22 to move laterally relative to, for example, a sidewall 33 defining the cavity 26. The lateral movement of the spring portion 28 will in turn cause the capacitive plate portion 30 to move laterally, as indicated by the arrows in Figures 3 and 4.

The capacitive plate portion 30 includes an electrically conductive material. For example, according to one embodiment the capacitive plate portion 30 may include one or more CMOS metal layers (not shown). In addition, the substrate assembly 24 may include a capacitive plate portion 34 adjacent the capacitive plate portion 30 of the beam 22. According to one embodiment, the capacitive plate portion 34 of the substrate assembly 24 may include one or more CMOS metal layers. Accordingly, lateral movement by the capacitive plate portion 30 of the beam 22 will cause the capacitance between the capacitive plate portions 30, 34 to vary in inverse proportion to their separation distance. This capacitance may be sensed by circuitry, such as solid-state circuitry integrated into the substrate assembly 24, to thereby determine the power of the incident IR radiation as described previously.

The thermal isolation portion 32 may provide an electrical connection between the capacitive plate portion 30 of the beam 22 and the substrate assembly circuitry while minimizing the thermal conductivity therebetween. In that way, the incident IR radiation may be effectively isolated in the beam 22 rather than dissipated in the substrate assembly 24. According to one embodiment, as explained further hereinafter, the thermal isolation portion 32 may include a polysilicon interconnect layer to provide the electrical connection to the capacitive plate portion 30.

Figures 5 and 6 illustrate the pixel 20 according to another embodiment of the present invention. Figure 5 is a top plan view of the pixel 20 and Figure 6 is cross-sectional view of the pixel 20 along line V-V'. As illustrated in Figures 5 and 6, the pixel 20 may include two cantilevered beams 22a-b. As described previously, each beam 22a-b may respectively include a spring portion 28a-b, a capacitive plate portion 30a-b and a thermal isolation portion 32a-b. According to such an embodiment, the capacitive plate portions

30a-b form a capacitor. As explained previously, the metal layers of spring portion 28a may be oriented on the side of the beam 22a adjacent to beam 22b and the metal layers of spring portion 28b may be oriented on the side of the beam 22b adjacent to beam 22a, or vice versa. In that way, incident IR radiation causes each of the spring portions 28a-b to move laterally, but in opposite directions, relative to the sidewall 33 of the cavity, thereby causing the capacitance between the capacitive plate portions 30a-b to vary. The capacitance between the capacitive plate portions 30a-b may be sensed, for example, by solid-state circuitry integrated in the substrate assembly 24.

Although the pixels described previously and hereinafter are described in the context of an IR sensitive pixel, it should be noted that the micromachined structure might be used for other purposes, such as a lateral actuator, a lateral resonant sensor and a temperature sensor.

Figures 7-9 illustrate a process for fabricating a pixel 20 according to an embodiment of the present invention. Figure 7 illustrates a cross-sectional view of a substrate assembly 40 having a circuitry layer 42 formed on a substrate 43. The circuitry layer 42 may be, for example, a CMOS circuitry layer, including CMOS circuitry regions 44 and CMOS interconnect regions 46, formed on the substrate 43 according to conventional CMOS fabrication techniques. The CMOS circuitry regions 44 may include, for example, CMOS circuits 45. For an embodiment in which the circuitry layer 42 is a CMOS circuitry layer, as illustrated in Figure 7, the CMOS circuitry layer 42 may include polysilicon layers 48, intermediate metal layers 50, and upper metal layers 52. The CMOS circuitry layer 42 may also include dielectric layers 54. The dielectric layers 54 may be, for example, an oxide layer such as, for example, silicon dioxide. The thickness of the CMOS circuitry layer 42 may be, for example, 5-7 μm . The substrate 43 may be, for example, a bulk silicon mass and may have a thickness of, for example, 400-800 μm .

Figure 8 illustrates the substrate assembly 40 after micromachining of the circuitry layer 42. In the illustrated embodiment, portions of the dielectric layers 54 of the CMOS circuitry layer 42 have been removed by a reactive ion etch (RIE). The upper metal layers 52 act as the etching mask such that only those portions of the dielectric layers 54 exposed by the upper metal layers 54 are removed. RIEs are directional (anisotropic), such that a

number microstructures 60 having well-defined sidewalls are formed. As in the illustrated embodiment, the microstructures 60 may include CMOS dielectric layers 54 and metal layers 50,52. The RIE may be performed with, for example, CHF_3 as the etchant gas in an O_2 plasma. CMOS micromachining processes used to create CMOS microstructures are further described in U.S. Patent 5,717,631 entitled "Microelectromechanical Structure and Process of Making Same" to Carley et al., and U.S. Patent 5,970,315, entitled "Microelectromechanical Structure and Process of Making Same" to Carley et al., which are incorporated herein by reference.

Figure 9 illustrates the substrate assembly 40 after an isotropic etch to remove portions of the substrate 43. According to one embodiment, a RIE may be used for the isotropic etch using, for example, sulfur hexafluoride (SF_6) as the etchant gas in an O_2 plasma. As illustrated in Figure 9, the isotropic etching step releases the microstructures 60 from the substrate 43 to form cantilevered beams. In another embodiment a RIE may be first used for a directional etch of the substrate 43, followed by an isotropic etch.

Figure 10 is a scanning electron micrograph (SEM) image of a pixel 20 according to another embodiment of the present invention. As can be seen in Figure 10, the beams 22a-b may have a meandering or folded shape. In addition, the capacitive plate portions 30a-b of the beams may include protruding finger beams configured to form an interdigitated capacitor. That is, the finger beams of the respective capacitive plate portions 30a-b are interleaved. The meandering shape design for the beams 22a-b of the illustrated embodiment maximizes the tip deflection of the spring portions 28a-b within the pixel area. Further, the interdigitated capacitor structure increases the capacitance of the pixel 20, hence increasing the sensitivity thereof. The dimensions for the pixel 20 given in Figure 10 are exemplary.

The pixel 20 of Figure 10 additionally includes a micromachined frame 70 connected to the substrate assembly 24 around the beams, which may be fabricated according to the conventional micromachining techniques such as those previously described. The frame 70 may include an embedded heater (not shown), which may be used to test the pixel 20 or to provide a temperature offset during operation. According to one embodiment, the structures of the beams 22a-b may be designed so that they have different

mechanical resonant frequencies. For example, the mechanical resonant frequency of the beam 22a may be 245kHz and the mechanical resonant frequency of the beam 22b may be 230 kHz.

Figure 11 is a SEM image of the thermal isolation portion 32 of a beam of the pixel and Figure 12 is a cross-sectional view of the thermal isolation portion 32 along line A-A'. According to the illustrated embodiment, the thermal isolation portion 32 includes slotted metal lines 72. The slots in the beam 22 interrupt the metallization layers of the microstructure, such as the upper metal layer 52, thereby decreasing the thermal conductivity between the capacitive plate portion of the beam and the substrate assembly. Electrical conductivity between circuitry in the substrate assembly and the capacitive plate portion of the beam may be provided by polysilicon interconnect layer 48. According to one embodiment, the polysilicon interconnect layer 48 may have a width of, for example, 0.6 μm .

The anchor portion 74 of the substrate assembly may include an electrically conductive via 76 to provide an electrical connection between the polysilicon interconnect layer 48 and the metal interconnect layer 50 of the substrate assembly circuitry. The via 76 may be made of metal such as, for example, tungsten or aluminum.

The beams 22 of the pixel 20 may take on numerous different configurations. Figure 13 is a top view of a pixel configuration according to another embodiment of the present invention. Like the embodiment illustrated in Figure 10, the capacitive plate portions 30a-b of the beams 22a-b in Figure 13 form an interdigitated capacitor. According to the illustrated embodiment, each capacitive plate portion 30a-b includes a main beam 77a-b having a number of finger beams 78 extending therefrom. The finger beams 78 from the respective capacitive plate portions 30a-b are interleaved to thereby form the interdigitated capacitor. During fabrication, the different residual stresses in the embedded layers of the spring portions 28a-b cause the finger beams 78 to move closer together after the mechanical release from the substrate, described previously, to thereby improve device sensitivity.

To enhance the efficiency of the IR sensitive pixels 20 described herein, an IR absorbing material (not shown) may be deposited on the pixel 20 such as, for example, by

sputtering. The IR absorbing material may be, for example, platinum black, gold black or carbon black. According to another embodiment, the IR absorbing material may be deposited on a plate over the pixel. Figure 14 is a side-view of a pixel 20 according to such an embodiment. As illustrated in Figure 14, a plate 80 made of, for example, a thermally
5 conductive material such as aluminum, is located over the beams (not shown) and supported by a post 82 connected to the frame 70. In this case, the thermal isolation portions between the frame 70 and the beams 28a-b may be omitted. The IR absorbing material 84 is deposited on the plate 80. The post 82 may also made of a thermally conductive material such as aluminum. Although only one post 82 is shown in Figure 14, more than one post
10 may be employed if necessary to support the plate. According to other embodiments, such as for pixels 20 that do not include a frame, the post(s) 82 may be directly connected to the beams 28a-b.

Pixels according to the present invention may be used in an infrared (IR) imager. Figure 15 is a diagram of an IR imager 100 according to one embodiment of the present
15 invention. According to one embodiment, the IR imager 100 may be integrated onto a single chip (or die). As illustrated in Figure 15, the imager 100 includes an array 101 of pixels 20 having N columns and M rows. The pixels 20 may be individually addressed by an addressing circuit 102 once every image scan. A pixel 20 in the M-th row and the N-th column may be selected when, for example, a N-th column bit line 104 and a M-th row bit
20 line 106 are driven to a logic high by the addressing circuit 102. The addressing circuit 102 may include, for example, shift registers and may be synchronized by a master clock 108. A capacitance detection circuit 112 may be coupled to the addressing circuit 102 to sense the change in capacitance of the addressed pixel.

Each pixel 20 may include an interface circuit 110 coupled to the addressing circuit
25 102. Figure 16 is a diagram of the interface circuit 110 according to one embodiment of the present invention. In Figure 16 the pixel 20 is represented as a variable capacitor, which is coupled to a reference capacitor 120. According to one embodiment, the capacitance of the reference capacitor 120 may be 5fF. The circuit 110 also includes a shared source follower configuration including, for example, NMOS field effect transistors (FETs) 122, 124, 126
30 and 128. The first transistor 122 may be controlled by a reset signal and the second

transistor 124 may be controlled by a reset compensation signal. The control terminal of the transistor 126 is coupled to the common node between the pixel 20 and the reference capacitor 120, and the source of the transistor 126 is coupled to the drain of the transistor 128. The transistor 128 is driven by the row bit line select signal from the addressing circuit 102, and the source of the transistor 128 is coupled to a column bit line from the addressing circuit 102. The capacitance bridge formed by the pixel 20 and the reference capacitor 120 may be driven by two out of phase signals, V_{REF}^+ and V_{REF}^- , which enable, as described hereinafter, double correlated sampling based capacitor detection. Any initial mismatch between the pixel 20 and reference capacitor 120 may be eliminated by adjusting the ratio between the positive and negative reference voltages, V_{REF}^+ and V_{REF}^- . The transistors 122 and 124 may be used to set the DC voltage at the output. Switch injection errors may be reduced by driving the transistor 124 with a signal (the reset compensation signal) that is a delayed and inverted version of the reset signal driving the transistor 122.

Figure 17 is a schematic of the array 101 of the imager 100 according to one embodiment. The active column is selected by, for example, a logic high on the appropriate column bit line from the addressing circuit (not shown) and the active pixel is selected, for example, by a logic high on the row bit lines from the addressing circuit. The capacitance detection circuit 112 may be shared by each pixel 20 of the array 101.

Figure 18 illustrates a sample clocking scheme for a 2 x 2 pixel array. The V_{REF}^+ and V_{REF}^- analog signals are input to the capacitive bridge as shown in Figure 16 and may be centered around analog ground. The frequency of the sampling is related to the scan rate of the image. The master clock frequency may be obtained by the relation:

$$F_{clock} = 2 (N)(M)(S)(n) \quad (2)$$

where N is the number of columns, M is the number of rows, S is the scan rate of the image, and n is the number of pixel output measurements made per cycle. For a 16 x 16 array, operating at 30 frames per second and one measurement per cycle, the master clock frequency would be 15.36 kHz.

Figure 19 is a schematic diagram of the capacitance detection circuit 112 according to one embodiment of the present invention using double correlated sampling to generate an

output voltage V_{out} that is proportional to the change in capacitance of the pixel 20 relative to the reference capacitor 120 (see Figure 16). The output from the pixel interface circuit 110 is coupled to a capacitor C_a that samples the DC offset voltage introduced by the interface circuit 110. The signal is amplified by an amplifier 130, and then the output, 5 clocked by sampling signals phase1 and phase2, is sampled on capacitors C_{s1} and C_{s2} respectively. The difference is calculated by a differential amplifier 132 and latched by a sample-and-hold circuit 134. The switch 136 of the sample-and-hold circuit 134 may be driven by sampling signal phase2 such that the output is valid on the falling edge of phase2.

The pixel performance of an initial design is summarized in Table 2. For a given 10 pixel area, optimal design is a careful trade-off between the area of the pixel and the thermal isolation. The Noise Equivalent Difference Temperature (NEDT) is the minimum temperature difference at the image source that the pixel can sense. NEDT can be improved to a certain extent by improving the thermal isolation, as the thermal time constant must be low enough to accommodate the image frame rate. However, the NEDT of 50 mK for this 15 design example does not include the performance boost from energy absorption enhancements.

TABLE 2: Sample Pixel Performance

<u>Symbol</u>	<u>Definition</u>	<u>Value</u>	<u>Unit</u>
A	Micromechanical pixel area	588	(μm) ²
L _{finger}	Finger Beam length	25	μm
L _{spring}	Spring length	20	μm
V _{mod}	Modulation voltage	3	V
F	F number of optics	1	-
G	Fill Factor	68	%
S _p	Positional sensitivity (FEA)	416	A/K
S _c	Capacitance sensitivity (FEA)	160	aF/K
R _{thermal}	Thermal isolation resistance	3.31×10^6	K-s/J
R _{radiation}	Radiative coupling resistance	9.87×10^6	K-s/J
C _{thermal}	Thermal capacity	6.79×10^{-9}	J/K
τ_{thermal}	Thermal constant	21	ms
β	Thermal transfer function	123	-
$\Delta T_{\text{thermal}}$	Thermal noise	35.8	$\mu\text{K}(\text{Hz})^{-1/2}$
ΔT_{photon}	Photon noise	2.46	$\mu\text{K}(\text{Hz})^{-1/2}$
ΔT_{amp}	Amplifier noise (CDS switched capacitor)	52.7	$\mu\text{K}(\text{Hz})^{-1/2}$
ΔT_{scene}	Total noise referred to the scene	8.75	$\text{mK}(\text{Hz})^{-1/2}$
Detectivity	Detectivity	3×10^9	$\text{cm}(\text{Hz})^{1/2}/\text{W}$
NEP	Noise equivalent power	4.02×10^{-9}	W
NEDT	NEDT (@ 30 Hz)	6.08	mK

The fill factor of the device, that determines the radiative coupling from the scene to the device, can be improved by integrating an array of, for example, silicon microlenses to focus infrared energy on the pixel. The microlens array may be, for example, integrated on the backside of the chip to decrease assembly costs.

The presence of sidewall area increases the radiative absorption area of the device. Sidewall infrared energy absorption may be enhanced by design and control of the etch depth during isotropic release of the microstructures.

An advantage of the present invention that may be realized in certain embodiments thereof is that a relatively large gap (10 – 20 μm) may be formed between the thermal mass of the pixel and the underlying substrate assembly. This large gap may have negligible thermal conductance relative to the thermal conductance of the pixel beams 22, which makes operation of an uncooled IR imager at atmospheric pressure feasible.

Although the present invention has been described herein with respect to certain embodiments, those of ordinary skill in the art will recognize that many modifications and variations of the present invention may be implemented. The foregoing description and the following claims are intended to cover all such modifications and variations.

CLAIMS

What is claimed is:

1. A pixel for an IR sensor, comprising:
a substrate assembly having a cavity defined by at least one sidewall;
5 and characterized by:
a cantilevered beam connected to the substrate assembly and disposed in the cavity,
the cantilevered beam including a first spring portion and a first capacitor plate portion,
wherein the first spring portion includes at least two materials having different coefficients
of thermal expansion; and
10 a second capacitor plate portion, such that incident IR radiation causes the first
spring portion of the cantilevered beam to move laterally relative to the sidewall, thereby
creating a variable capacitance between the first capacitor plate portion of the cantilevered
beam and the second capacitor plate portion.
2. The pixel of claim 1, wherein the cantilevered beam further includes a first
15 thermal isolation portion between the substrate assembly and the first spring portion.
3. The pixel of claim 1, wherein the cantilevered beam includes a CMOS
micromachined beam.
4. The pixel of claim 1, wherein the first spring portion includes a metal layer
and a dielectric layer with different coefficients of thermal expansion.
- 20 5. The pixel of claim 4, wherein the metal layer includes aluminum and the
dielectric layer includes silicon dioxide.
6. A pixel for an IR sensor, comprising:
a substrate assembly having a cavity defined by at least one sidewall;
and characterized by:
25 a first cantilevered beam connected to the substrate assembly and disposed in the
cavity, the first cantilevered beam including a first spring portion and a first capacitor plate
portion, wherein the first spring portion includes at least two materials having different
coefficients of thermal expansion; and
a second cantilevered beam connected to the substrate assembly and disposed in the
30 cavity, the second cantilevered beam including a second spring portion and a second

capacitor plate portion, wherein the second spring portion includes at least two materials having different coefficients of thermal expansion such that incident IR radiation causes the first and second spring portions to move laterally relative to the sidewall thereby creating a variable capacitance between the first and second capacitor plate portions.

5 7. The pixel of claim 6, wherein:

 the first cantilevered beam further includes a first thermal isolation portion between the substrate assembly and the first spring portion; and

 the second cantilevered beam further includes a second thermal isolation portion between the substrate assembly and the second spring portion.

10 8. The pixel of claim 6, wherein:

 the first cantilevered beam includes a CMOS micromachined beam; and

 the second cantilevered beam includes a CMOS micromachined beam.

 9. The pixel of claim 6, wherein:

15 the first spring portion includes a metal layer and a dielectric layer with different coefficients of thermal expansion; and

 the second spring portion includes a metal layer and a dielectric layer with different coefficients of thermal expansion.

 10. The pixel of claim 9, wherein:

20 the metal layer of the first spring portion includes aluminum and the dielectric layer of the first spring portion includes silicon dioxide; and

 the metal layer of the second spring portion includes aluminum and the dielectric layer of the second spring portion includes silicon dioxide.

 11. The pixel of claim 6, wherein:

25 the first cantilevered beam has a shape selected from the group consisting of straight, meandering and curved; and

 the second cantilevered beam has a shape selected from the group consisting of straight, meandering and curved.

 12. The pixel of claim 6, further comprising a frame connected to the substrate assembly and positioned around the first and second cantilevered beams.

13. The pixel of claim 12, further comprising:

at least one post connected to the frame;

a plate connected to the post; and

an IR absorbing material located on the plate.

5 14. The pixel of claim 6, wherein:

the first capacitor plate portion includes a beam having a plurality of finger beams extending therefrom; and

the second capacitor plate portion includes a beam having a plurality of finger beams extending therefrom such that the finger beams of the first capacitor plate portion are
10 interleaved with the finger beams of the second capacitor plate portion.

15. The pixel of claim 6 wherein a resonant mechanical frequency of the first cantilevered beam does not equal a resonant mechanical frequency of the second cantilevered beam.

16. The pixel of claim 6, further comprising:

15 at least one post connected to one of the first and second cantilevered beams;

a plate connected to the post; and

an IR absorbing material located on the plate.

17. A micromachined pixel for an IR sensor, comprising:

a substrate assembly having a cavity defined by at least one sidewall;

20 and characterized by:

a first CMOS micromachined, cantilevered beam connected to the substrate assembly and disposed in the cavity, the first CMOS micromachined, cantilevered beam including a first spring portion and a first capacitor plate portion, wherein the first spring portion includes a metal layer and a dielectric layer having different coefficients of thermal
25 expansion; and

a second CMOS micromachined cantilevered beam connected to the substrate assembly and disposed in the cavity, the second cantilevered beam including a second spring portion and a second capacitor plate portion, wherein the second spring portion includes a metal layer and a dielectric layer having different coefficients of thermal
30 expansion, such that incident IR radiation causes the first and second spring portions to

move laterally relative to the sidewall thereby creating a variable capacitance between the first and second capacitor plate portions.

18. The pixel of claim 17, wherein:

the first CMOS micromachined, cantilevered beam further includes a first thermal
5 isolation portion between the substrate assembly and the first spring portion; and

the second CMOS micromachined cantilevered beam further includes a second thermal isolation portion between the substrate assembly and the second spring portion.

19. The pixel of claim 18, wherein:

the first thermal portion includes at least one slotted metal line; and
10 the second thermal portion includes at least one slotted metal line.

20. The pixel of claim 19, further comprising a frame connected to the substrate assembly and positioned around the first and second CMOS micromachined, cantilevered beams.

21. The pixel of claim 20, further comprising:

15 at least one post connected to the frame;
a plate connected to the post; and
an IR absorbing material located on the plate.

22. The pixel of claim 19, wherein:

the first capacitor plate portion includes a beam having a plurality of finger beams
20 extending therefrom; and

the second capacitor plate portion includes a beam having a plurality of finger beams extending therefrom such that the finger beams of the first capacitor plate portion are interleaved with the finger beams of the second capacitor plate portion.

23. The pixel of claim 17, wherein a resonant mechanical frequency of the first
25 CMOS micromachined, cantilevered beam does not equal a resonant mechanical frequency of the second CMOS micromachined, cantilevered beam.

24. The pixel of claim 19, further comprising:

at least one post connected to one of the first and second CMOS micromachined, cantilevered beams;
30 a plate connected to the post; and

an IR absorbing material located on the plate.

25. A micromachined structure, comprising:

a substrate assembly having a cavity defined by at least one sidewall;

and characterized by:

5 a first cantilevered beam connected to the substrate assembly and disposed in the cavity, the first cantilevered beam including a first spring portion and a first capacitor plate portion, wherein the first spring portion includes at least two materials having different coefficients of thermal expansion; and

10 a second capacitor plate portion, such that incident IR radiation causes the first spring portion of the cantilevered beam to move laterally relative to the sidewall, thereby creating a variable capacitance between the first capacitor plate portion of the first cantilevered beam and the second capacitor plate portion.

26. The micromachined structure of claim 25, wherein the first cantilevered beam further includes a first thermal isolation portion between the substrate assembly and
15 the first spring portion.

27. The micromachined structure of claim 25, wherein the first cantilevered beam includes a CMOS micromachined beam.

28. The micromachined structure of claim 25, wherein the second capacitor plate portion is part of a second cantilevered beam that is connected to the substrate assembly and
20 disposed in the cavity, the second cantilevered beam including a spring portion connected to the second capacitor plate portion, wherein the second spring portion includes at least two materials having different coefficients of thermal expansion, such that incident IR radiation causes the second spring portion to move laterally relative to the sidewall.

29. The micromachined structure of claim 28, wherein:

25 the first capacitor plate portion includes a beam having a plurality of finger beams extending therefrom; and

the second capacitor plate portion includes a beam having a plurality of finger beams extending therefrom such that the finger beams of the first capacitor plate portion are interleaved with the finger beams of the second capacitor plate portion.

30. The micromachined structure of claim 25, further comprising a frame connected to the substrate assembly and positioned around the first and second cantilevered beams.

5 31. An infrared (IR) imager, comprising:
an addressing circuit; and
a pixel array coupled to the addressing circuit, wherein the pixel array includes a plurality of IR sensitive pixels;

and characterized in that each pixel includes:

10 a first cantilevered beam connected to a substrate assembly and disposed in a cavity of the substrate assembly, wherein the cavity is defined by a sidewall, wherein the first cantilevered beam includes a first spring portion and a first capacitor plate portion, and wherein the first spring portion includes at least two materials having different coefficients of thermal expansion; and

15 a second capacitor plate portion, such that incident IR radiation causes the first spring portion of the cantilevered beam to move laterally relative to the sidewall, thereby creating a variable capacitance between the first capacitor plate portion of the first cantilevered beam and the second capacitor plate portion.

20 32. The IR imager of claim 31, wherein the first cantilevered beam further includes a first thermal isolation portion between the substrate assembly and the first spring portion.

33. The IR imager of claim 31, wherein the first cantilevered beam includes a CMOS micromachined beam.

25 34. The IR imager of claim 31, wherein the second capacitor plate portion is part of a second cantilevered beam that is connected to the substrate assembly and disposed in the cavity, the second cantilevered beam including a spring portion connected to the second capacitor plate portion, wherein the second spring portion includes at least two materials having different coefficients of thermal expansion, such that incident IR radiation causes the second spring portion to move laterally relative to the sidewall.

35. The IR imager of claim 34, wherein:

the first capacitor plate portion includes a beam having a plurality of finger beams extending therefrom; and

the second capacitor plate portion includes a beam having a plurality of finger beams extending therefrom such that the finger beams of the first capacitor plate portion are interleaved with the finger beams of the second capacitor plate portion.

36. The IR imager of claim 31, further comprising a frame connected to the substrate assembly and positioned around the first and second cantilevered beams.

37. The IR imager of claim 31, further comprising an interface circuit coupled to each pixel.

38. The IR imager of claim 37, further comprising a capacitance detection circuit coupled to the addressing circuit.

39. An infrared (IR) imager, comprising:
an addressing circuit; and

a pixel array coupled to the addressing circuit, wherein the pixel array includes a plurality of IR sensitive pixels;
and characterized in that each pixel includes:

a first cantilevered beam connected to a substrate assembly and disposed in a cavity of the substrate assembly, wherein the cavity is defined by a sidewall, the first cantilevered beam including a first spring portion and a first capacitor plate portion, wherein the first spring portion includes at least two materials having different coefficients of thermal expansion; and

a second cantilevered beam connected to the substrate assembly and disposed in the cavity, the second cantilevered beam including a second spring portion and a second capacitor plate portion, wherein the second spring portion includes at least two materials having different coefficients of thermal expansion such that incident IR radiation causes the first and second spring portions to move laterally relative to the sidewall thereby creating a variable capacitance between the first and second capacitor plate portions.

40. The IR imager of claim 39, wherein:

the first cantilevered beam of each pixel further includes a first thermal isolation portion between the substrate assembly and the first spring portion; and

the second cantilevered beam of each pixel further includes a second thermal isolation portion between the substrate assembly and the second spring portion.

5 41. The IR imager of claim 39, wherein:

the first cantilevered beam of each pixel includes a CMOS micromachined beam; and

the second cantilevered beam of each pixel includes a CMOS micromachined beam.

10 42. The IR imager of claim 39, wherein:

the first spring portion of each pixel includes a metal layer and a dielectric layer with different coefficients of thermal expansion; and

the second spring portion of each pixel includes a metal layer and a dielectric layer with different coefficients of thermal expansion.

15 43. The IR imager of claim 39, wherein each pixel further includes a frame connected to the substrate assembly and positioned around the first and second cantilevered beams.

20 44. The IR imager of claim 43, wherein each pixel further includes:

at least one post connected to the frame;

a plate connected to the post; and

an IR absorbing material located on the plate.

25 45. The IR imager of claim 39, wherein each pixel further includes:

at least one post connected to one of the first and second cantilevered beams;

a plate connected to the post; and

an IR absorbing material located on the plate.

30 46. The IR imager of claim 39, wherein:

the first capacitor plate portion of each pixel includes a beam having a plurality of finger beams extending therefrom; and

the second capacitor plate portion of each pixel includes a beam having a plurality of finger beams extending therefrom such that the finger beams of the first capacitor plate portion are interleaved with the finger beams of the second capacitor plate portion.

47. The IR imager of claim 39, further comprising an interface circuit coupled to each pixel.

48. The IR imager of claim 47, further comprising a capacitance detection circuit coupled to the addressing circuit.

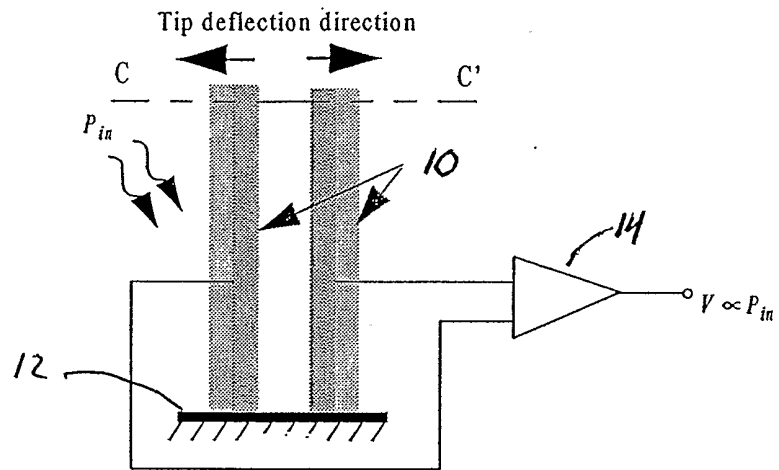

Fig. 1

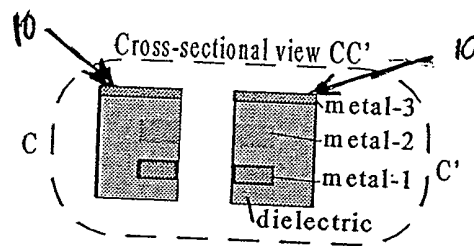
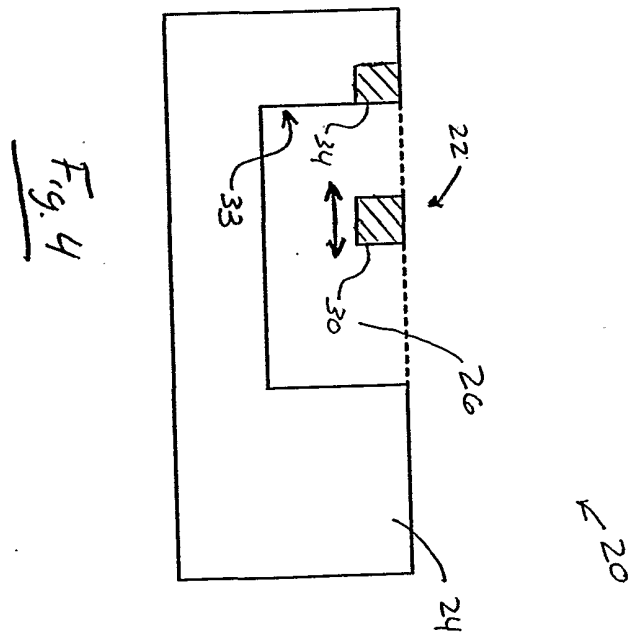
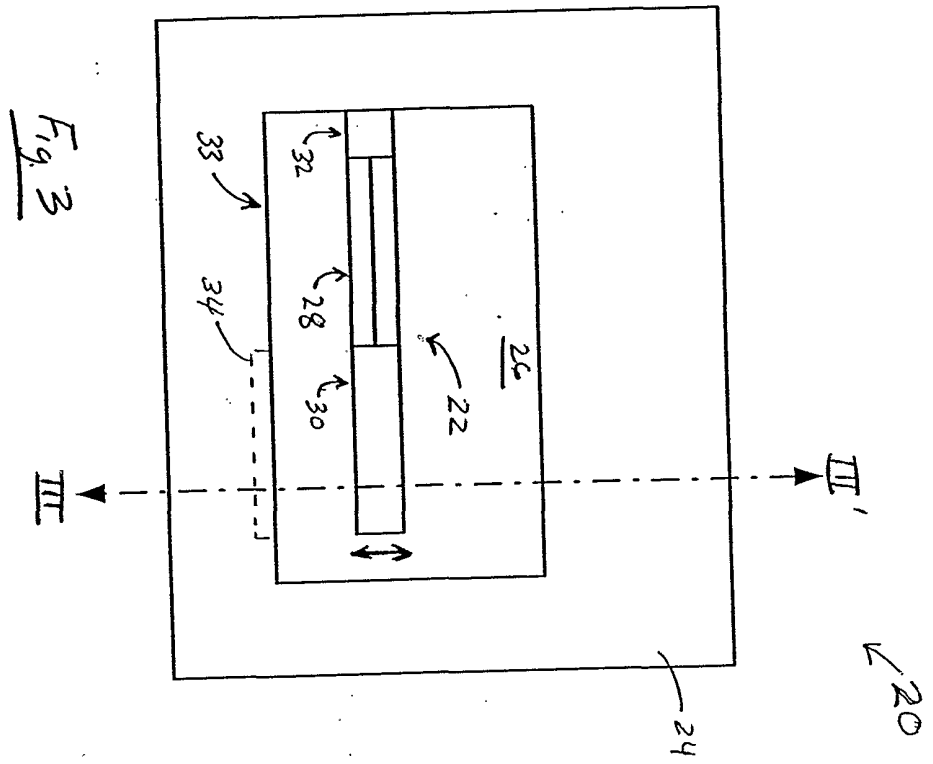

Fig. 2



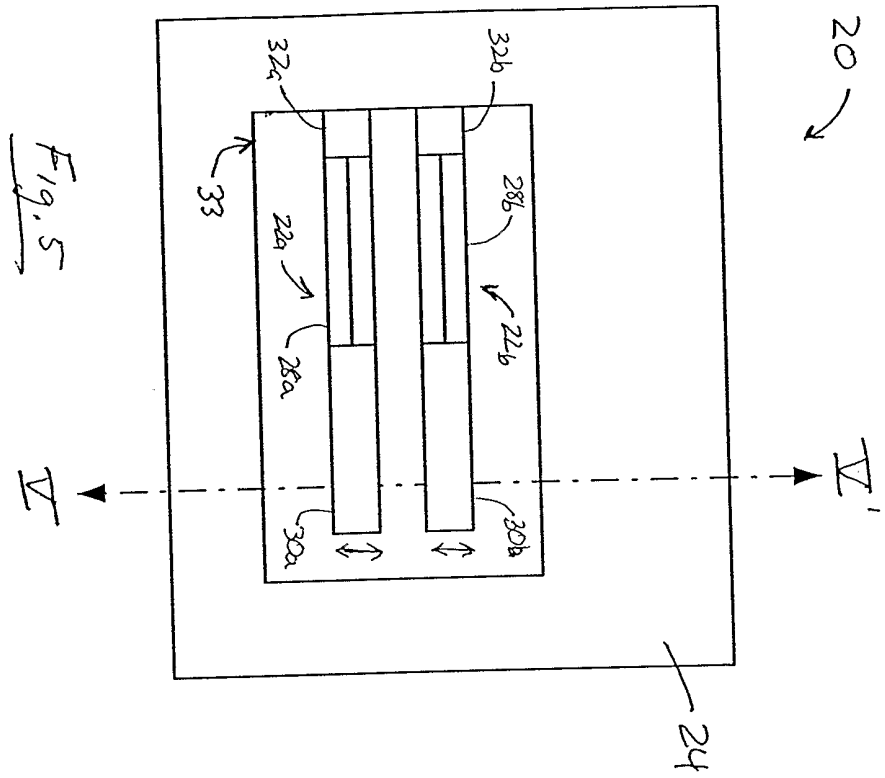

Fig. 5

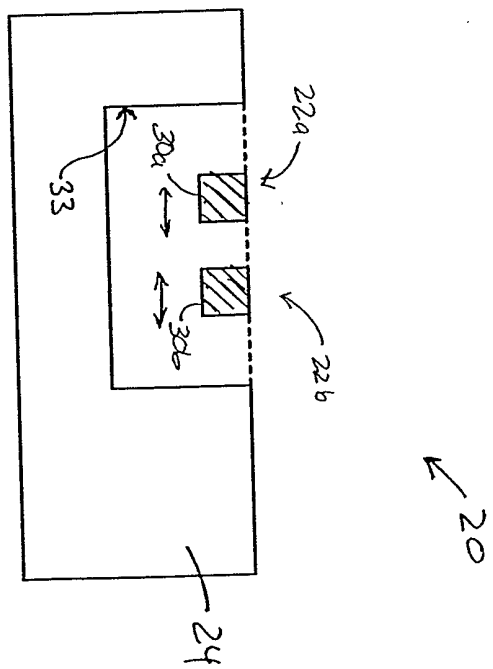
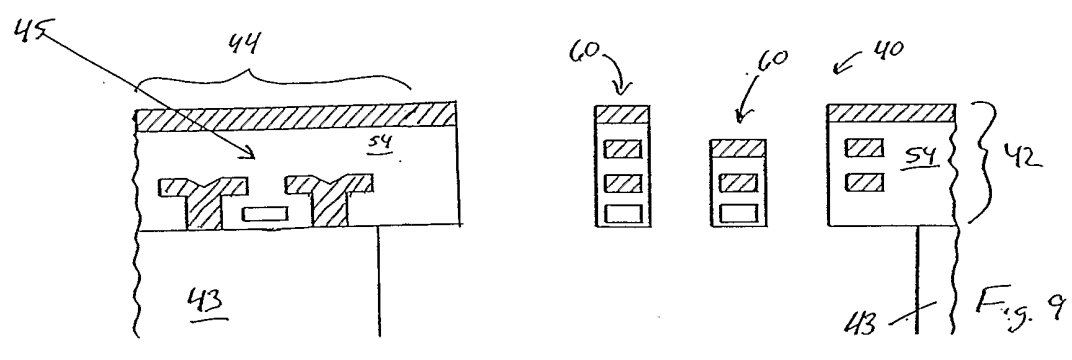
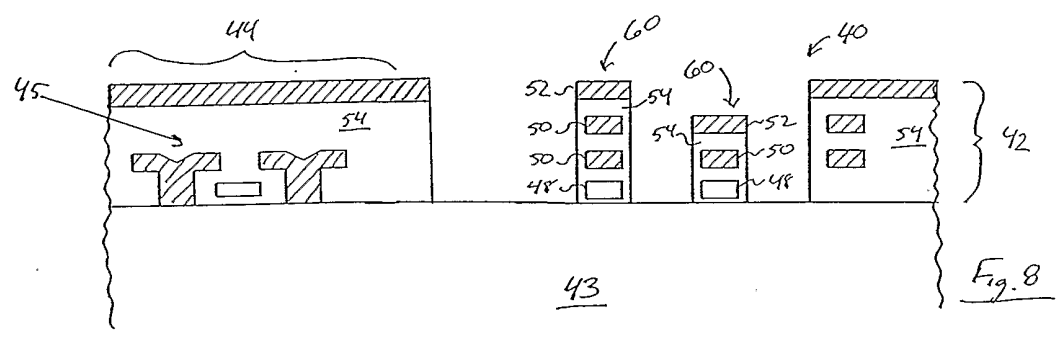
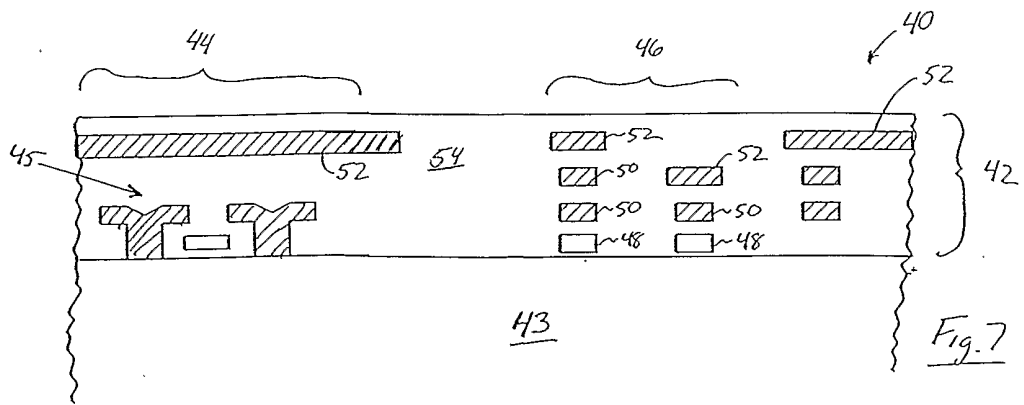

Fig. 6



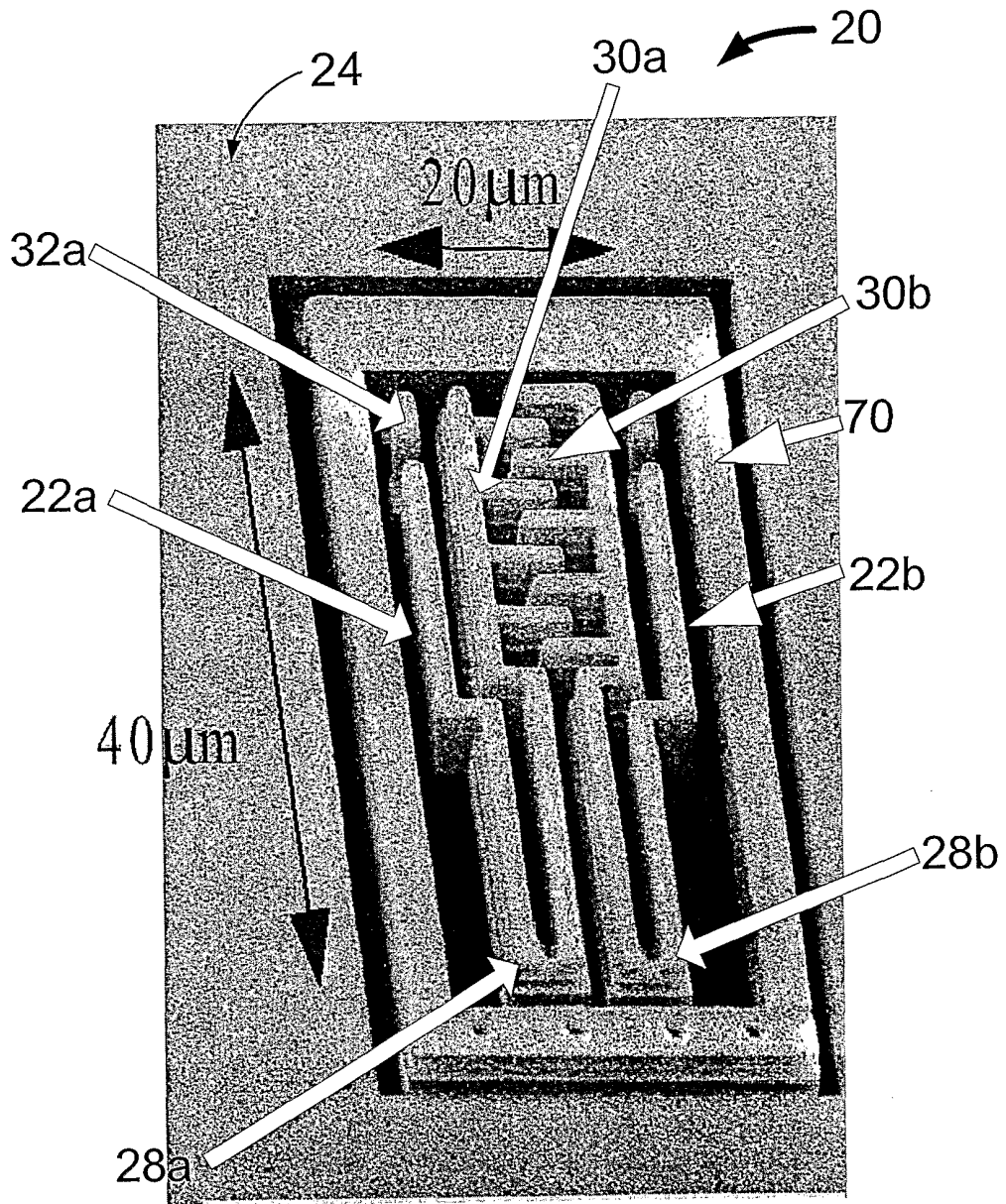

FIG. 10

6/13

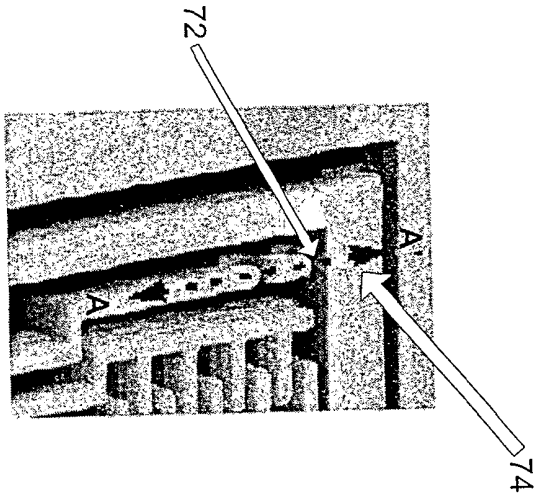

Fig. 11

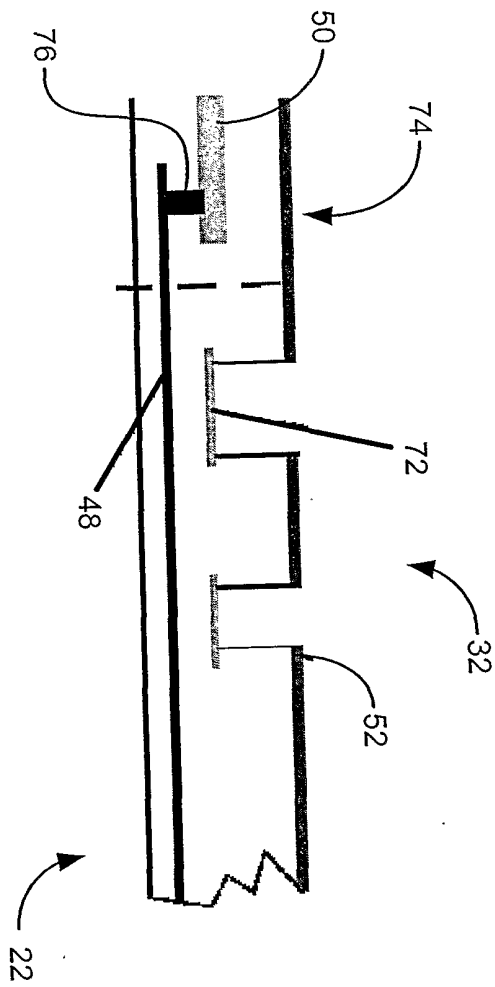

Fig. 12

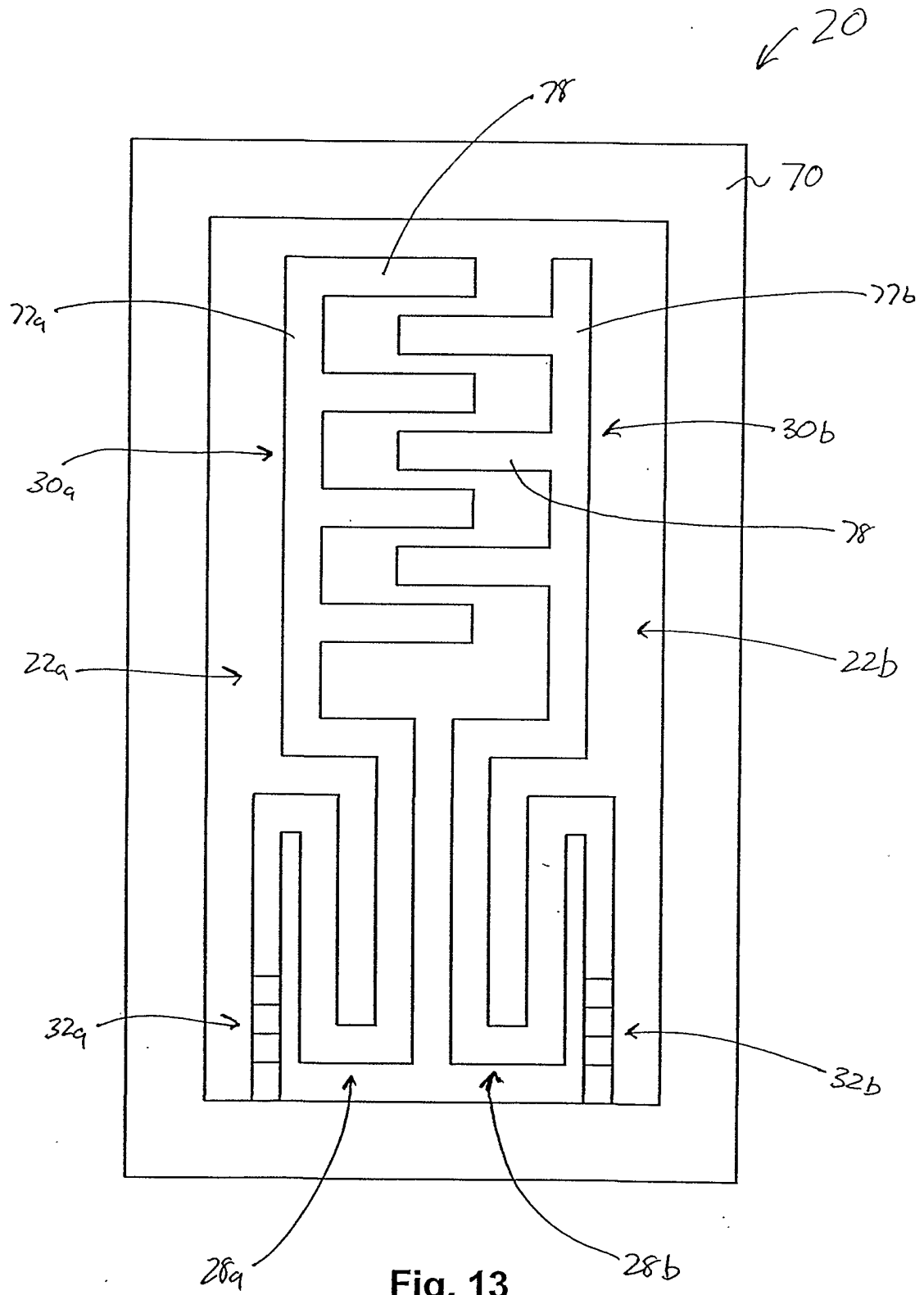

Fig. 13

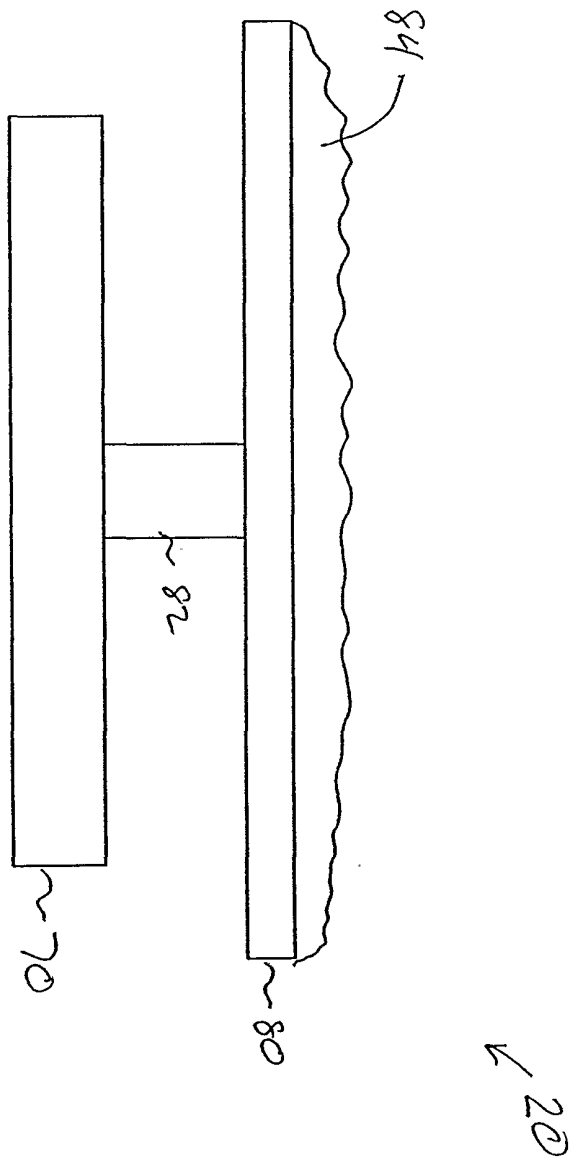

Fig. 14

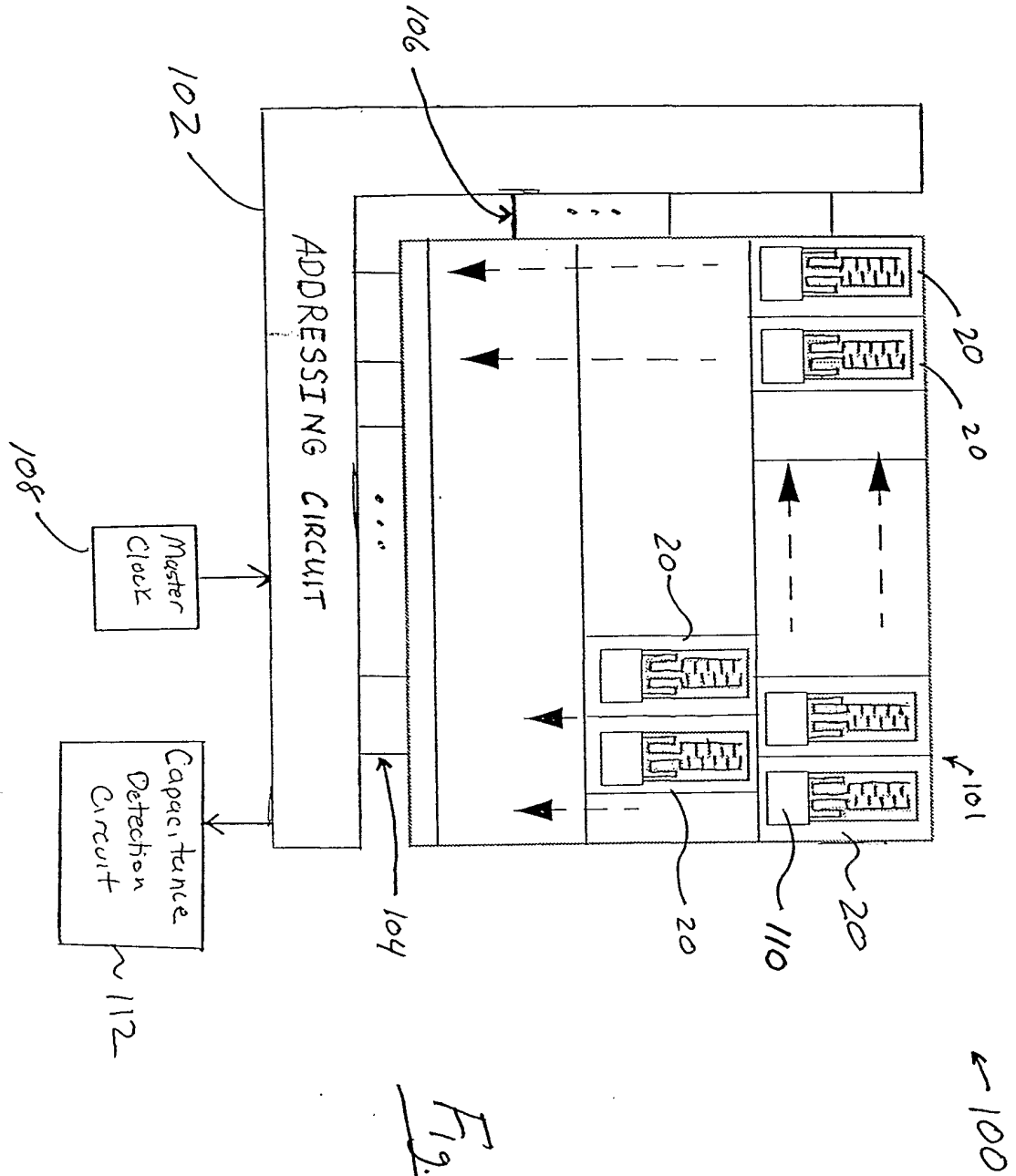

Fig. 15

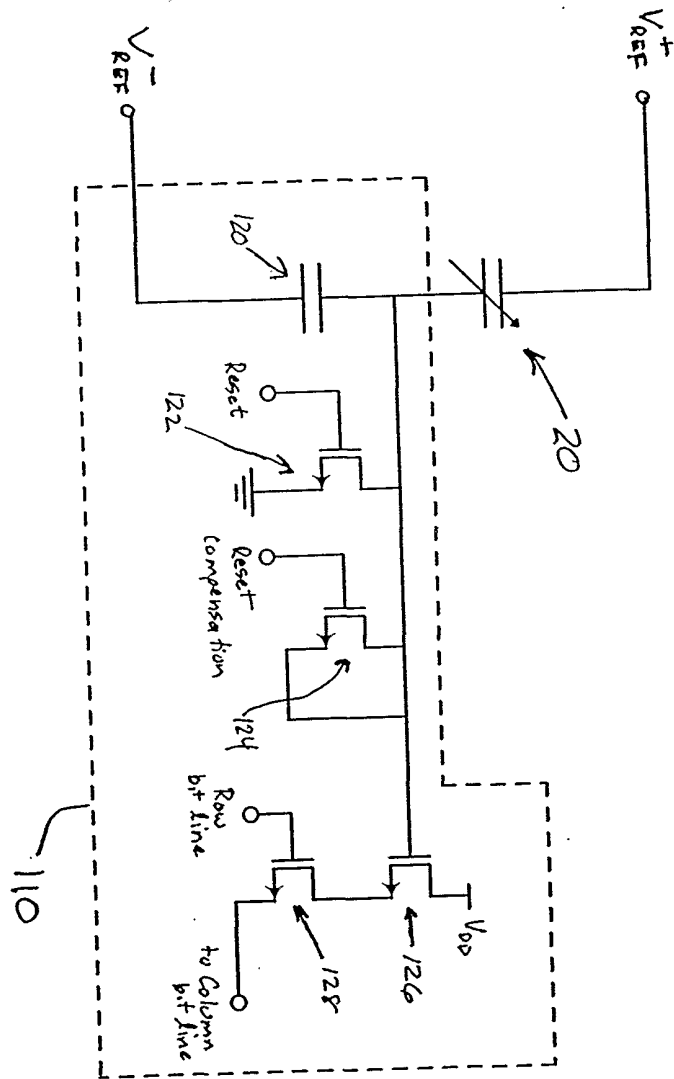

Fig. 16

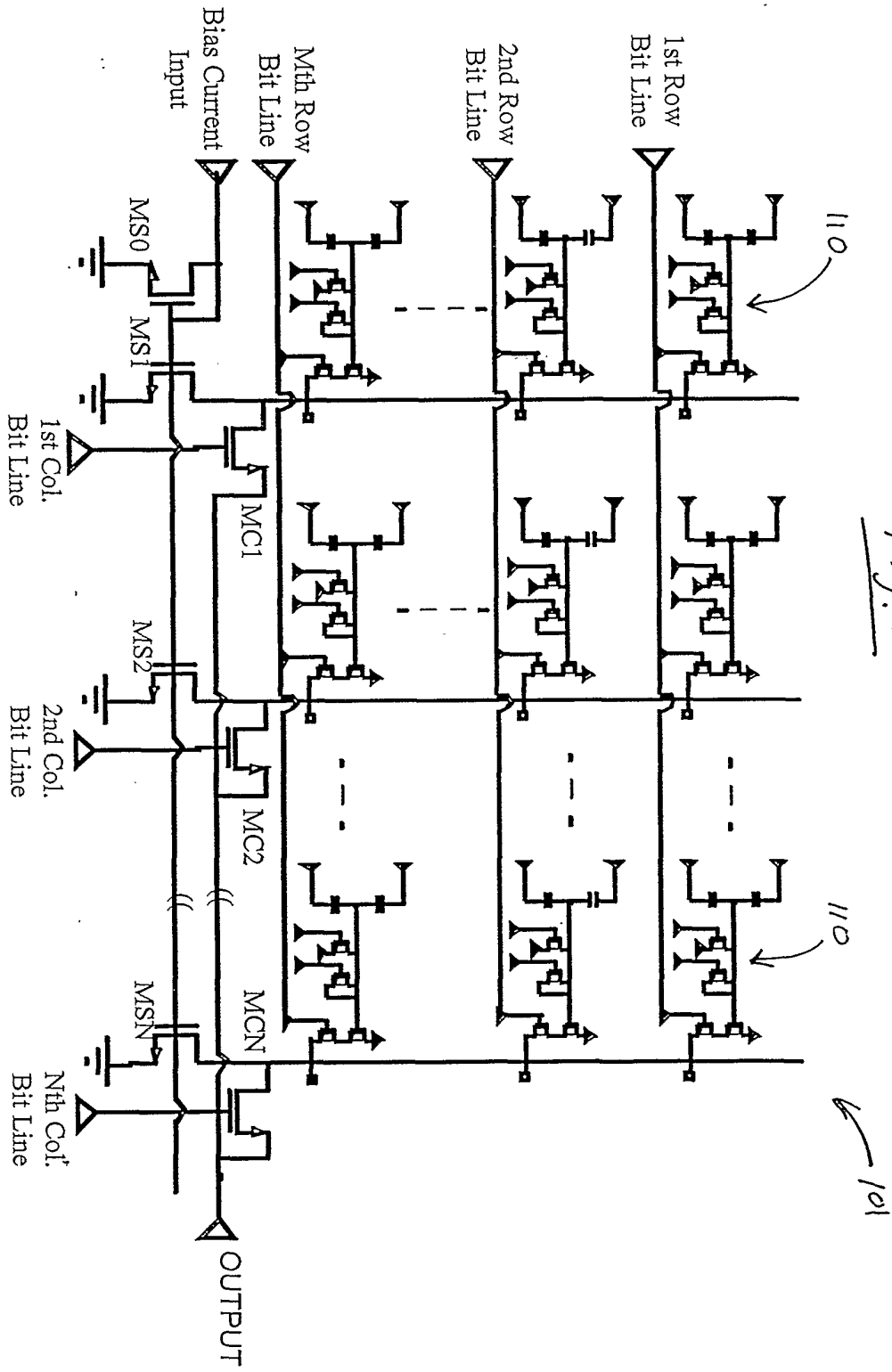
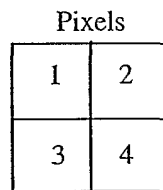
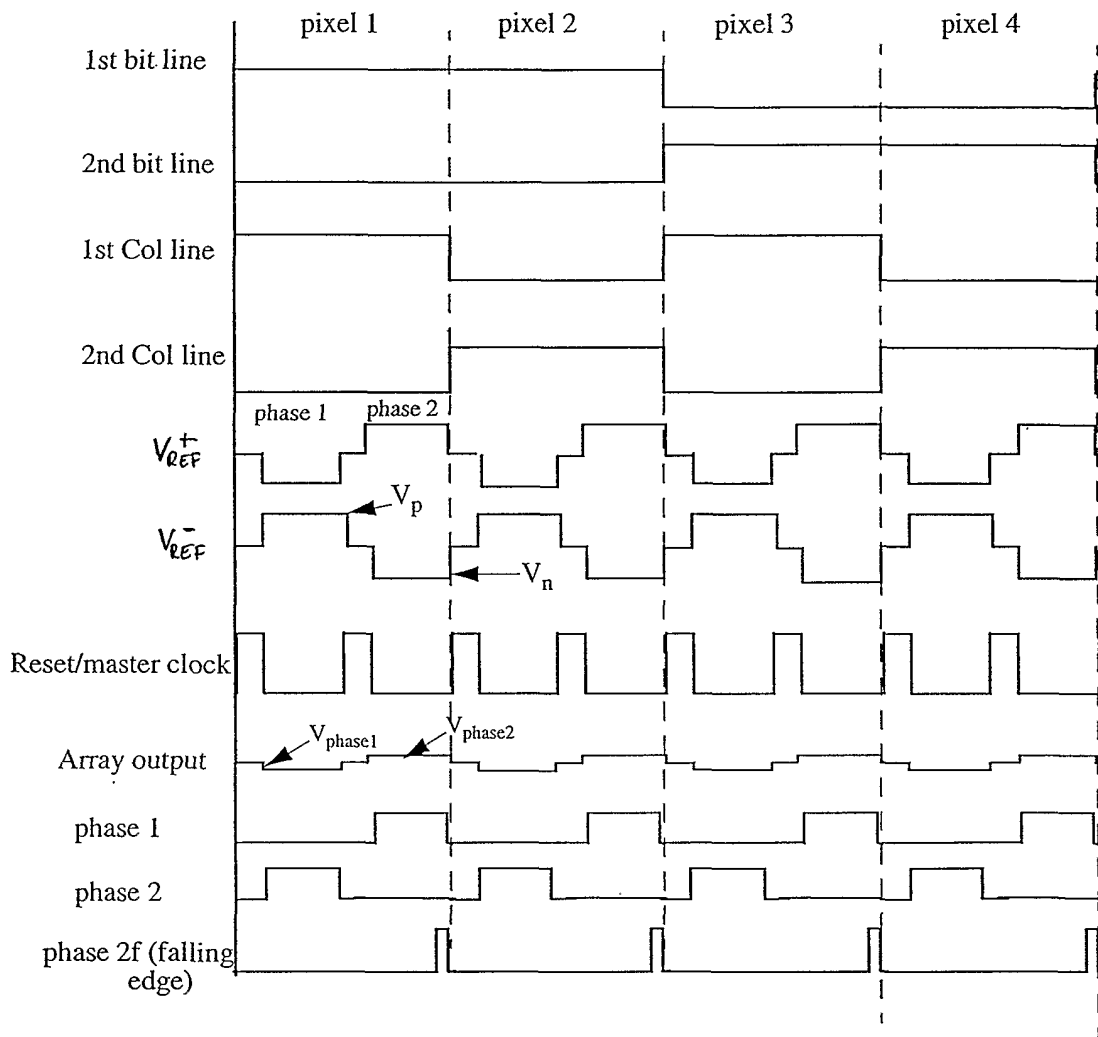

Fig. 17



Schematic of the 2x2 array

Fig. 18

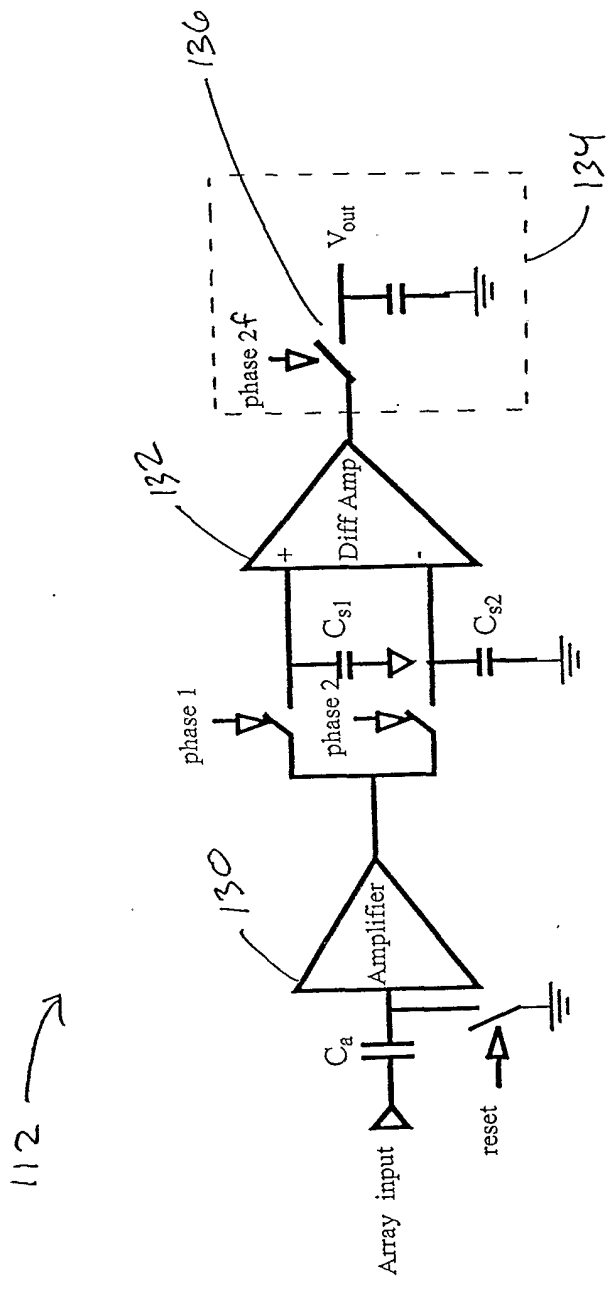

Fig. 19