

(19)
(12)

(KR)
(B1)

(51) 。 Int. Cl. ⁶
H01L 21/78

(45)
(11)
(24)

2003 02 19
10 - 0363076
2002 11 19

(21) 10 - 1995 - 0007595
(22) 1995 03 31

(65) 1996 - 0035965
(43) 1996 10 28

(73) 3 416

(72) 2 294 - 201

17 408

(74)

:

(54)

가
(3), (1 2) (3)

, CMP

1a

1A 1E

2A 2C

3A 3E 1

4A 4E 2

5A 5E 3

* *

28, 42a, 54b:" "

22, 42, 54: . 24, 44, 56: .

30, 50a, 60;

(trench)

(locos)

가

가

(

)

(trench))

가

가

(hump)

2μm

(void)가 . p 가 .
 가 (pitch) 가 .
 , 가 가 .
 SWAMI(side wall masked isolation), SEPOX(selective polysilicon oxidation)
 BOX(buried oxide isolation) (LOCOS) (trench))

1A 1E

1A (1) (3)
 (5) 1 (7) 1 (7)
 (5) (3) (1)
 2 (9) 2 (9a) 2
 (9) 1 (7), (5) (3) (9a)
 2 (9)

1B (trench) (9a)
 1A (1)
 (10)가

1C 1B (10) 3 (13)

1D 1C (5)
 1C 2 (7)

1E 1D (5) (3) (15)

2A 2C

2A (2) (4)
 (2)
 (4) (6)
 (PRI) (PRI)
 (PRI) (6) (4) (8)
 (PRI)

2B 2A (8)

가 (10)

(4) (10) (10, 10a)
(6) 가 . .

2C 2B (6) (4) (10)
(10)

가 , (Chemical Mechanical Polishing (dishing effect)가 . 가 ,
(hump) . 가 ,

가

1

" , 가 " " , "
, (CMP)

2

" " " " ,
,

3

가

1, 2 3 100 - 300 (CMP) 1,500 - 2,500

1 2, 3 1

2 1 1

3 2

2 1 3 가 1 2

ishing)

가

가

CMP (d

3A 3E 1

3A (24) (20) (22)

()

100 - 300 (24) 1,500 - 2,500A (26)가 (22)

3B 3A (26)가 3A " " (28)

3C " " (28) (24) 3B
 (28a) (29) 가

3D 3C (CVD) 3B
 , 3C (28a) CVD

3E (24) CMP - (etch - back) 3D (24)
 (22) (30) 가

1 (28a) 가 (28a)
 (30) (hump)

4A 4E 2

4A , (42)
 (44) 1

4B 4A
 4A (46) (42) (PR2)
 (42a, 42b)

4C (PR2) 4B
 (40) (49) (48) (48)
 (PR2)

4D CVD (50)

4E - (etch - back) 4D (44)
 (42) CMP 4D (44)
 가 (50)
 (profile)
 (50a) (50b)

5A 5E 3

5A (55) 2 .

5B (57) , 5A (55)
(58)

5C 5B (58a) " " ,
(58b)가 .

5D (60, 54b) , 5C (58a, 58b)
(58b) (62). 5C (58a)

5E , 5D (56) (54) (60)
(54b)

, 1 " " (28a)
가 (28a) (30)
 . 2 3 (hump)
가
(dishing) CMP
가

(57)

1.

;

;

;

;

"

"

;

" " ;
 ;
 ;
 (CMP) ;

2.

;
 ;
 " " ;
 " " ;
 ;
 ;
 (CMP) ;

3.

" " ;
 가 ;
 ;
 ;
 " " ;
 ;

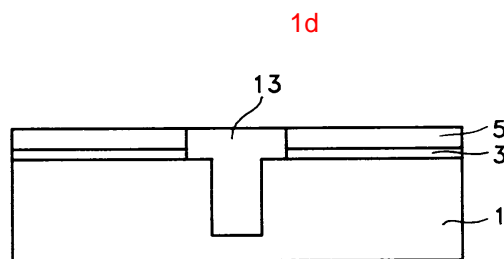
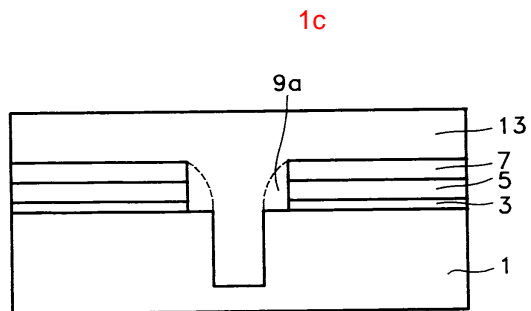
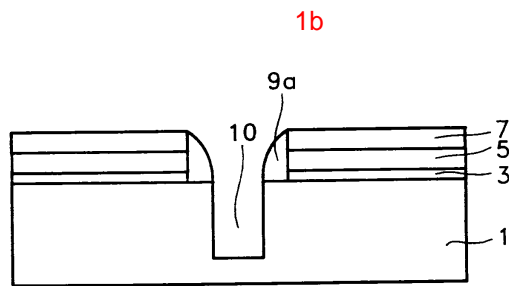
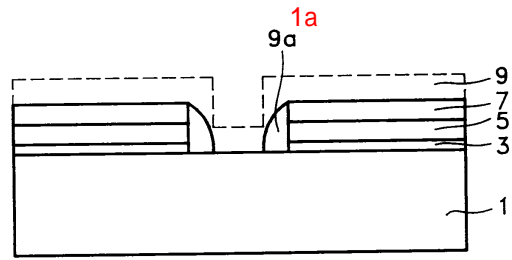

1e

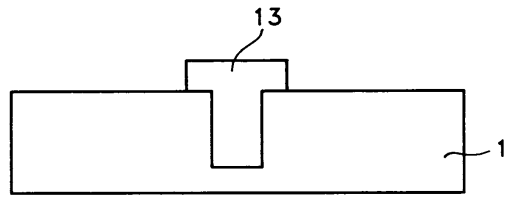

2a

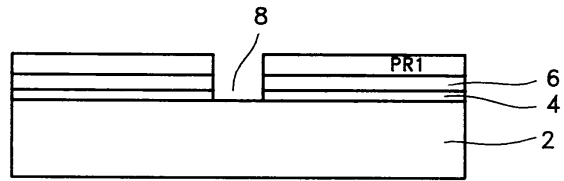

2b

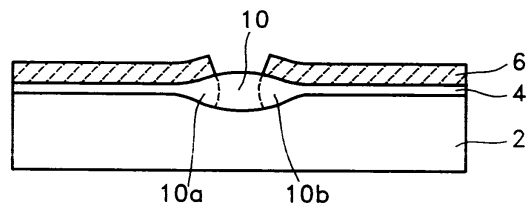

2c

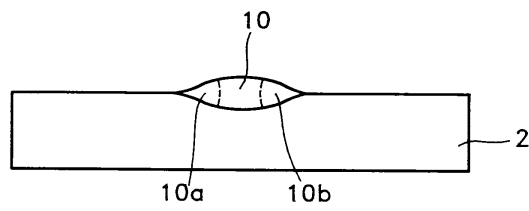

3a

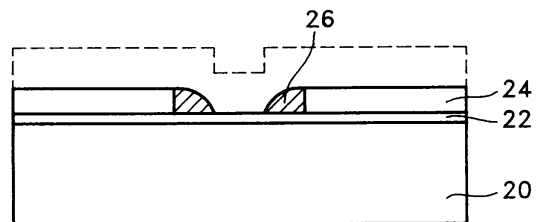

3b

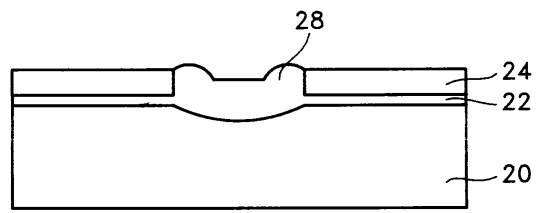

3c

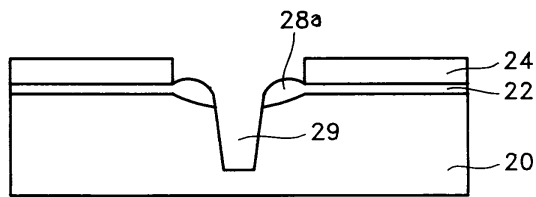

3d

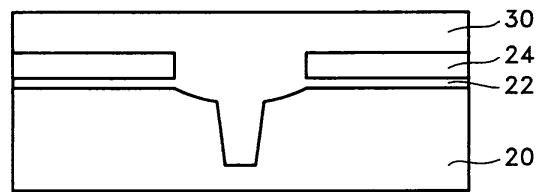

3e

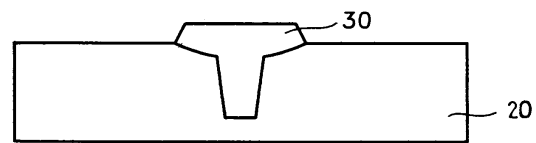

4a

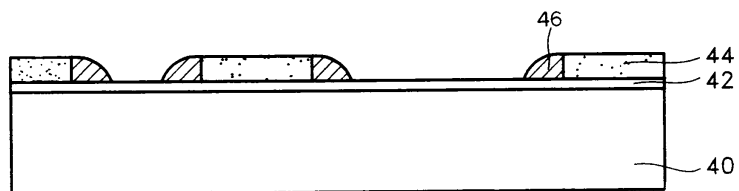

4b

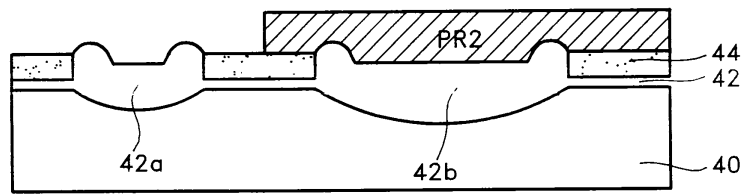

4c

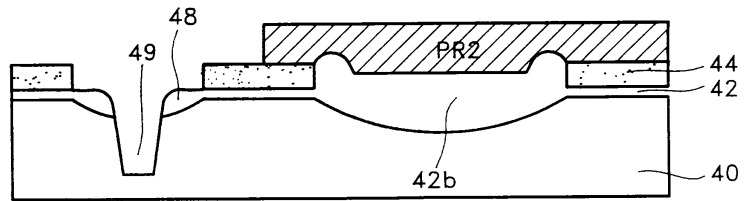

4d

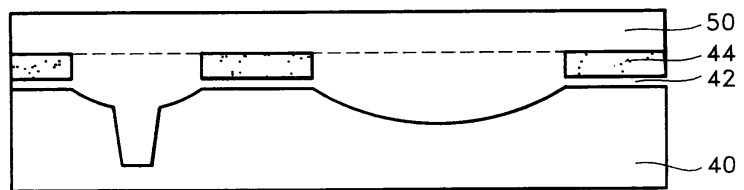

4e

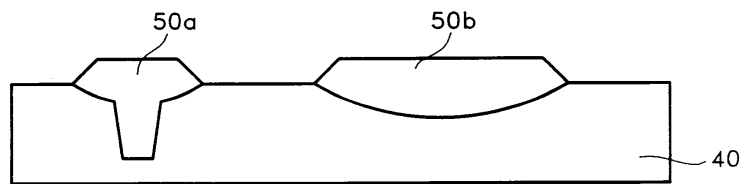

5a

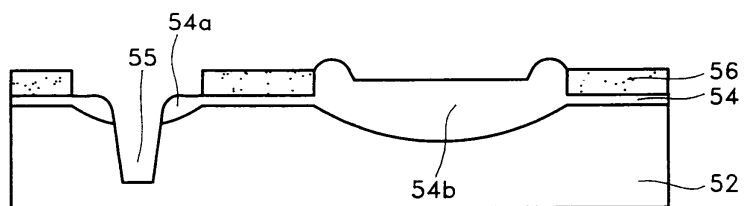

5b

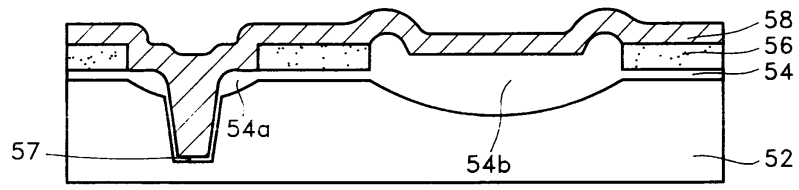

5c

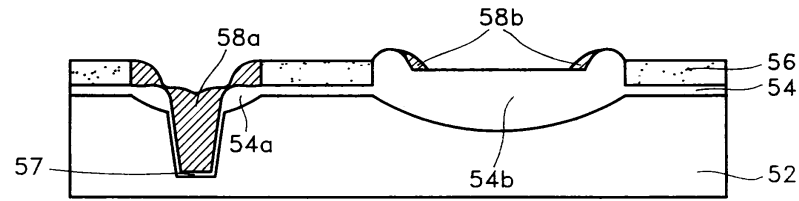

5d

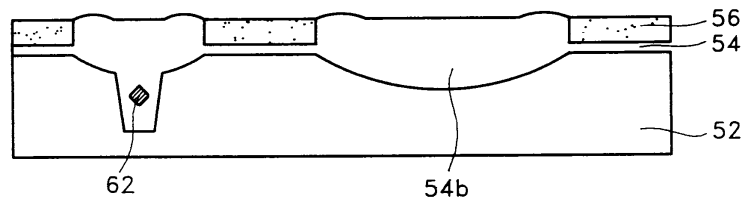

5e

