

(19) World Intellectual Property Organization
International Bureau



(43) International Publication Date
16 August 2001 (16.08.2001)

PCT

(10) International Publication Number
WO 01/58509 A1

(51) International Patent Classification⁷: A61M 1/28

Patrick; 69, rue Louis Berteau, B-5032 Bothey (BE). **BE-LONGIE, Duane**; 2014 25th Avenue South, Minneapolis, MN 55406 (US).

(21) International Application Number: PCT/US01/04083

(22) International Filing Date: 8 February 2001 (08.02.2001)

(81) Designated States (*national*): AT, AU, BR, CA, CH, CN, DE, DK, ES, GB, ID, IN, JP, KR, MX, SE, SG.

(25) Filing Language: English

(84) Designated States (*regional*): European patent (AT, BE, CH, CY, DE, DK, ES, FI, FR, GB, GR, IE, IT, LU, MC, NL, PT, SE, TR).

(26) Publication Language: English

(30) Priority Data:
09/501,778 10 February 2000 (10.02.2000) US

Published:
— with international search report
— before the expiration of the time limit for amending the claims and to be republished in the event of receipt of amendments

(71) Applicant: **BAXTER INTERNATIONAL INC.**
[US/US]; Charles R. Mattenson, One Baxter Parkway, DF3-3E, Deerfield, IL 60015 (US).

(72) Inventors: **CHILDERS, Robert**; 8816 Bel Meadow Way, New Port Richey, FL 34655 (US). **EERLINGEN, Vital**; Pasteelsblokweg 31, B-3010 Leuven (BE). **BALTEAU,**

For two-letter codes and other abbreviations, refer to the "Guidance Notes on Codes and Abbreviations" appearing at the beginning of each regular issue of the PCT Gazette.

(54) Title: METHOD AND APPARATUS FOR MONITORING AND CONTROLLING PERITONEAL DIALYSIS THERAPY

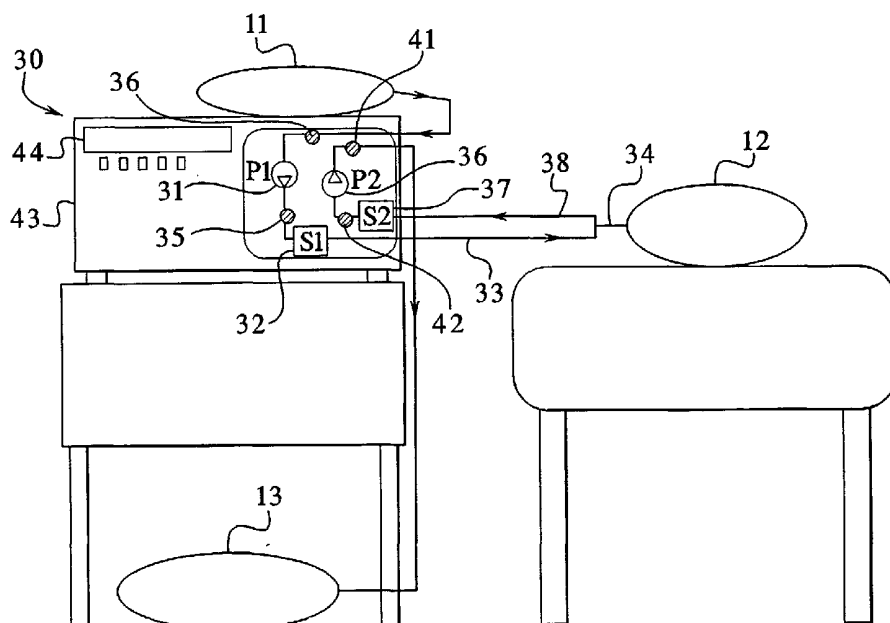

(57) Abstract: An automated peritoneal dialysis system and method are provided for monitoring and controlling automated peritoneal dialysis therapy based upon intraperitoneal pressure measured at a point near the end of the patient catheter during the fill, dwell and drain phases of automated peritoneal dialysis therapy.



WO 01/58509 A1

SPECIFICATION

TITLE

"METHOD AND APPARATUS FOR MONITORING AND CONTROLLING PERITONEAL DIALYSIS THERAPY"

5

BACKGROUND OF THE INVENTION

The present invention relates generally to the treatment of end stage renal disease. More specifically, the present invention relates to methods and apparatus for monitoring
10 the performance of peritoneal dialysis.

Using dialysis to support a patient whose renal function has decreased to the point where the kidneys no longer sufficiently function is known. Two principal dialysis methods are utilized: hemodialysis; and peritoneal dialysis.

In hemodialysis, the patient's blood is passed through an artificial kidney dialysis
15 machine. A membrane in the machine acts as an artificial kidney for cleansing the blood. Because it is an extracorporeal treatment that requires special machinery, certain inherent disadvantages exist with hemodialysis.

To overcome the disadvantages associated with hemodialysis, peritoneal dialysis was developed. Peritoneal dialysis utilizes the patient's own peritoneum as a semi-
20 permeable membrane. The peritoneum is a membranous lining of the abdominal body cavity. Due to good perfusion, the peritoneum is capable of acting as a natural semi-permeable membrane.

Peritoneal dialysis periodically infuses sterile aqueous solution into the peritoneal cavity. This solution is called peritoneal dialysis solution, or dialysate. Diffusion and
25 osmosis exchanges take place between the solution and the blood stream across the natural body membranes. These exchanges remove the waste products that the kidneys normally excrete. The waste products typically consist of solutes like urea and creatinine. The kidneys also maintain the levels of other substances such as sodium and water which need to be regulated by dialysis. The diffusion of water and solutes across
30 the peritoneal membrane during dialysis is called ultrafiltration.

In continuous ambulatory peritoneal dialysis, a dialysis solution is introduced into the peritoneal cavity utilizing a catheter. An exchange of solutes between the dialysate

and the blood is achieved by diffusion. Further removal is achieved by providing a suitable osmotic gradient from the blood to the dialysate to permit water outflow from the blood. This allows a proper acid-base, electrolyte and fluid balance to be achieved in the body. The dialysis solution is simply drained from the body cavity through the
5 catheter.

Peritoneal dialysis raises a number of concerns including: the danger of peritonitis; a lower efficiency and therefore increased duration of dialysis hours compared to hemodialysis; and costs incurred when automated equipment is utilized.

A number of variations on peritoneal dialysis have been explored. One such
10 variation is automated peritoneal dialysis ("APD"). APD uses a machine, called a cyclor, to automatically infuse, dwell, and drain peritoneal dialysis solution to and from the patient's peritoneal cavity. APD is particularly attractive to a peritoneal dialysis patient, because it can be performed at night while the patient is asleep. This frees the patient from the day-to-day demands of continuous ambulatory peritoneal dialysis during his/her
15 waking and working hours.

The APD sequence typically lasts for several hours. It often begins with an initial drain cycle to empty the peritoneal cavity of spent dialysate. The APD sequence then proceeds through a succession of fill, dwell, and drain phases that follow one after the other. Each fill/dwell/drain sequence is called a cycle. APD can be and is practiced in
20 a number of different ways.

Current APD systems do not monitor the patient intraperitoneal pressure during a therapy session. Current systems simply limit the external pressure (or suction) that a pump can apply to the line or lumen that is attached to the patient catheter. If the patient is located below the system, sometimes referred to as a cyclor, a gravity head will add to
25 the positive fill pressure that the cyclor can apply to the patient catheter. Conversely, if the patient is located above the cyclor, the gravity head will decrease from the positive fill pressure that the cyclor can apply to the patient catheter.

The monitoring of intraperitoneal pressure would be useful because cyclers will sometimes not fully drain a patient between cycles. Specifically, currently-available
30 cyclers are unable to determine whether a patient absorbed some fluid or whether some

fluid is simply not able to be drained out because of the position of the patient or the catheter.

As a result, some currently-available systems utilize a minimum drain threshold to determine the amount of fluid that should be delivered to the patient during the next
5 fill. For example, if 85% of the fill volume has been drained when the cyclor determines that the patient is "empty", the next fill volume will be 100%. If only 80% were drained, the next fill volume would be limited to 95%.

A negative ultrafiltrate (uF) alarm will sound when the patient has retained more than a predetermined percentage of the fill volume. The predetermined percentage can
10 typically be either 50% or 100% of the fill volume. However, the patient can override this alarm if he/she does not feel overfull. The number of times the patients can override the uF alarm during a single therapy may be limited by the software of the cyclor. However, the uF alarm typically does not consider the actual ultrafiltrate that may also accumulate in the peritoneal cavity along with the dialysate.

15 Currently-available cyclors fill the patient to a specific, preprogrammed volume during each cycle. The doctor prescribes this fill volume based upon the patient's size, weight and other factors. However, because currently-available cyclors cannot monitor intraperitoneal pressure, the doctor cannot take this factor into account when formulating the prescription. It is also known that intraperitoneal pressure (IPP) has an effect on
20 ultrafiltration (UF).

Figures 1-3 provide schematic illustrations of current APD cyclors. None of them attempt to monitor intraperitoneal pressure.

Referring to Figure 1, a cyclor 10a is illustrated which includes a dialysate container 11, a patient 12 and a drain container 13 are illustrated schematically. The
25 infusion of dialysate from the container 11 into the patient 12 is caused by the gravitational head indicated at 14 while the draining of used dialysate from the patient 12 to the drain container 13 is caused by the drain head indicated at 15. The cyclor 10a includes no sensors for monitoring the pressure inside the peritoneum of the patient 12. A single lumen 16 connects both the dialysate container 11 and drain container 13 to the
30 patient 12. Valves 17, 18 operated by the cyclor 10a control the flow of either dialysate

from the container 11 to the patient 12 or waste material from the patient 12 to the drain container 13.

Turning to Figure 2, in the cyclor 10b, the drain container 13 and dialysate container 11 are contained within a pressurized chamber 19. The chamber 19 can be
5 pressurized or evacuated to either fill or drain the patient. Again, the selective operation of valves 17, 18 control whether dialysate is being transferred to or from the patient 12. Again, no sensors are provided for detecting or monitoring intraperitoneal pressure of the patient 12.

Turning to Figure 3, in the system 10c, a dialysate container 11 is connected to
10 a pump 21 which, in turn, connects the dialysate container 11 to a common lumen or catheter 16 which is connected to the patient. A fluid flow control valve is provided at 23 and is controlled by the cyclor 10c. The drain container 13 is also connected to a pump 24 which, in turn, connects the drain container 13 to the lumen 16. A control valve is again provided at 25.

15 The drain and fill rates of the cyclors 10a-10c illustrated in Figures 1-3 are determined by the gravitational head (see Figure 1) or the suction or pressure (see Figures 2 and 3) applied to the patient line 16. Typically, the cyclors 10a-10c fail to optimize either the fill rate or the drain rate because the pressure is either fixed by the gravitational head or the pressure or suction applied by the chamber 10b of Figure 2 which occurs at
20 the opposing end of the patient line 16. Thus, without measuring the intraperitoneal pressure or having a way to estimate the same, it is difficult to optimize either the drain or fill rate. In the case of the cyclor 10c in Figure 3, optimizing the drain or fill rate is guesswork due to the lack of any pressure reading at all.

Accordingly, there is a need for an improved cyclor that measures patient
25 intraperitoneal pressure during a therapy session, including both during the drain and the fill as well as the dwell. Further, there is a need for an improved cyclor that measures intraperitoneal pressure and which would use that data to more completely drain a patient between cycles. Further, there is a need for an improved cyclor which would accurately measure intraperitoneal pressure to avoid overfilling a patient. Finally, there is a need
30 for an improved cyclor which would monitor intraperitoneal pressure during both the fill

and drain cycles to optimize the speed at which the patient is filled and drained and to therefore increase the dwell portion of a therapy session.

SUMMARY OF THE INVENTION

5 The present invention satisfies the aforementioned needs by providing a system for providing peritoneal dialysis to a patient which comprises a dialysate container connected to the patient with a first pressure sensor connected in-line therebetween, and a drain container connected to the patient with a second pressure sensor connected in-line therebetween.

10 In an embodiment, the system further comprises a first pump disposed in-line between the dialysate container and the first pressure sensor.

 In an embodiment, the dialysate flows from the dialysate container into the patient under a hydrostatic head.

15 In an embodiment, a second pump is disposed in-line between the drain container and the second pressure sensor.

 In an embodiment, the dialysate flows from the patient to the drain container under a hydrostatic head.

 In an embodiment, the second pressure sensor measures an intraperitoneal pressure of the patient while dialysate flows from the dialysate container to the patient.

20 In an embodiment, the first pressure sensor measures an intraperitoneal pressure of the patient while dialysate flows from the patient to the drain container.

25 In an embodiment, the system further comprises a first lumen connecting the dialysate container to the first sensor and the first sensor to a catheter, and a second lumen connecting the drain container to the second sensor and the second sensor to the catheter, the catheter being connected to the patient, a flow of dialysate from the patient to the drain container evacuating dialysate from the first lumen and causing said dialysate from the first lumen to flow through the second lumen and to the drain container.

 In an embodiment, the catheter is a dual lumen catheter.

30 In an embodiment, the first and second sensors are redundant in-line pressure/vacuum sensors.

In an embodiment, the present invention provides a method for dialyzing a patient comprising the steps of: placing a catheter in a peritoneum of the patient; providing at least one dialysate container; connecting the dialysate container to the catheter with a first lumen that includes a first pressure sensor disposed in-line and between the catheter and
5 the dialysate container; providing at least one drain container; connecting the drain container to the catheter with a second lumen that includes a second pressure sensor disposed in-line and between the catheter and the drain container; transferring dialysate from the dialysate container to the peritoneum of the patient and monitoring an intraperitoneal pressure of the patient with the second pressure sensor; and transferring
10 dialysate from the peritoneum of the patient to the drain container and monitoring the intraperitoneal pressure of the patient with the first pressure sensor.

In an embodiment, the step of transferring dialysate from the dialysate container to the peritoneum of the patient further comprises pumping dialysate from the dialysate container to the patient with a first pump disposed in-line between the dialysate container
15 and the first pressure sensor.

In an embodiment, the step of transferring dialysate from the peritoneum of the patient to the drain container further comprises pumping dialysate from the peritoneum of the patient to the drain container with a second pump disposed in-line between the
20 drain container and the second pressure sensor.

In an embodiment, the dialysate container is disposed vertically above the peritoneum of the patient and the step of transferring dialysate from the dialysate container to the peritoneum of the patient further comprises flowing dialysate from the
25 dialysate container to the patient under a hydrostatic head.

In an embodiment, the drain container is disposed vertically below the peritoneum
25 of the patient and the step of transferring dialysate from the peritoneum of the patient to the drain container further comprises flowing dialysate from the peritoneum of the patient to the drain container under a hydrostatic head.

Other objects and advantages of the invention will become apparent upon reading the following detailed description and appended claims, and upon reference to the
30 accompanying drawings.

BRIEF DESCRIPTION OF THE FIGURES

Figure 1 illustrates, schematically, a prior art automated peritoneal dialysis system;

Figure 2 illustrates, schematically, a prior art automated peritoneal dialysis system;

Figure 3 illustrates, schematically, a prior art automated peritoneal dialysis system;

Figure 4 illustrates, schematically, an automated peritoneal dialysis system made in accordance with the present invention;

Figure 5 illustrates, schematically, a second embodiment of an automated peritoneal dialysis system made in accordance with the present invention;

Figure 6 illustrates, schematically, a third embodiment of an automated peritoneal dialysis system made in accordance with the present invention;

Figure 7 illustrates, schematically, a fourth embodiment of an automated peritoneal dialysis system made in accordance with the present invention;

Figure 8 illustrates a pressure sensor made in accordance with the present invention;

Figure 9 illustrates a fifth embodiment incorporating dual pumping chambers and pressure sensors made in accordance with the present invention;

Figure 10 illustrates, schematically, a dual lumen catheter that can be utilized with the present invention;

Figure 11 is a sectional view taken substantially along line 11-11 of Figure 10;

Figure 12 illustrates, graphically, the urea concentration in blood and the urea concentration in a dialysate during a multiple dwell dialysis session;

Figure 13 illustrates, graphically, the concentration of urea in a patient's bloodstream versus the concentration of urea in a dialysate solution for an automated peritoneal dialysis solution practiced in accordance with the prior art; and

Figure 14 illustrates, graphically, the concentration of urea in a patient's bloodstream versus the concentration of urea in a dialysate for an automated peritoneal dialysis therapy session carried out in accordance with the present invention.

It should be understood that the drawings are not necessarily to scale and that the embodiments are sometimes illustrated by graphic symbols, phantom lines, diagrammatic representations and fragmentary views. In certain instances, details which are not necessary for an understanding of the present invention or which render other details
5 difficult to perceive may have been omitted. It should be understood, of course, that the invention is not necessarily limited to the particular embodiments illustrated herein.

DETAILED DESCRIPTION OF THE PRESENTLY PREFERRED EMBODIMENTS

10 Turning to Figure 4, a cycler 30 includes a dialysate container 11 connected to a pump 31. The pump 31 is connected to a pressure sensor 32. The pump 31 and pressure sensor 32 are disposed in-line in a lumen 33 that connects the dialysate container 11 to a catheter 34. Control valves are provided at 35, 36. A drain container 13 is also
15 connected to a pump 36 which is connected to a sensor 37. The pump 36 and sensor 37 are also connected in-line to a lumen 38 which connects the drain container 13 to the catheter 34. Control valves are again provided at 41, 42. During the fill, the pump 31 pumps dialysate from the container 11 through the lumen 31 and catheter 34 into the peritoneum (not shown) of the patient 12. During this time, the sensor 37 monitors and measures the intraperitoneal pressure. A signal is sent to the controller of the cycler 30
20 shown schematically at 43. A control panel is indicated generally at 44.

During the drain, the sensor 31 can accurately monitor and measure the intraperitoneal pressure of the patient 12. In the embodiment illustrated in Figure 4, no pumps or control valves are disposed between the sensor 32 and the patient 12.

Turning to Figure 5, a cycler 50 is illustrated which includes reversible pumping
25 chambers 51, 52 with sensors 53, 54 disposed between the reversible pumping chambers 51, 52 and the patient 12 respectively. Control valves 55 and 56 are disposed on another side of the reversible pumping chamber 51 and the sensor 53 and control valves 57, 58 are provided on either side of the reversible pumping chamber 52 and sensor 54. The sensors 53, 54 actually measure the pressure on the diaphragms of the reversible pumping
30 chambers 51, 52.

Turning to Figure 6, a cyclor 60 is illustrated with a chamber 61 for accommodating the drain container 13 and a chamber 62 for accommodating the dialysate container 11. Each chamber 61, 62 is equipped with an integrated valve assembly and pressure sensor shown at 63, 64. In the embodiment 60 shown in Figure 6, the chamber 61 must be capable of being evacuated. Dialysate may flow from the dialysate container 11 by way of gravity or pressure fill. Again, the sensors of the valve assembly/sensor combinations 63, 64 monitor the intraperitoneal pressure of the patient 12 as discussed above.

In the embodiment 70 illustrated in Figure 7, the dialysate container 11 and drain container 13 are both connected to integrated control valves and pressure sensors 71, 72. Each of the integrated control valves and pressure sensors 71, 72 are connected to lumens 73, 74 respectively which are connected to the catheter 75a by way of a Y-connection. The details of all the Y-connections and clamps are not shown but are known to those skilled in the art. Flow from the dialysate container 11 to the patient is carried out under the gravitational head shown at 75 while flow from the patient to the drain container 13 is carried out under the gravitational head shown at 76.

Figure 8 illustrates one in-line pressure sensor 80 that is suitable for use with the present invention. Redundant load cells 81, 82 are connected to the flexible pressure sensing membrane 83 by a vacuum connected by the line 84, 85. A lumen connecting the cyclor to the patient is shown at 86.

Figure 9 illustrates a dual-pumping chamber cassette 87 which includes an output line 88 which connects the cassette 87 to the patient and an input line 89 connecting the patient to the cassette 87. The line 90 connects the cassette 87 to the dialysate container (not shown). Each pumping chamber 91, 92 are in communication with all three lines 88, 89 and 90. Thus, every line can be connected to either pumping chamber 91, 92. The pumping chambers 91, 92 are bound on one side by a common diaphragm shown at 93. Flow is controlled by the use of diaphragm valves shown at 94, 95, 96 and 97. Pressure sensors are shown at 120, 121, 122, 123, 124, 125. However, pressure sensors 123 and 120 are the sensors used to measure intraperitoneal pressure in accordance with the present invention. The remaining sensors 121, 122, 124, 125 are used to monitor the operation of the pumps 126, 127.

When the left diaphragm pump 126 is pushing dialysate to the patient, the sensor 123 can measure the intraperitoneal pressure through the line 89. When the left diaphragm pump 126 is draining fluid from the patient through the line 89, the sensor 120 can measure intraperitoneal pressure through the line 88 and while the right pump 27 is pumping fluid to the drain container (not shown) through the drain line shown schematically at 128. When the right diaphragm pump 127 is being used to drain fluid from the patient, the sensor 120 can measure intraperitoneal pressure while the left diaphragm pump 126 is pumping fluid to the drain container (not shown) through the drain line shown schematically at 129.

Figures 10 and 11 illustrate a dual-lumen catheter 100 which includes separate passageways 101, 102. The employment of a dual lumen catheter 100 as compared to a dual lumen patient line can move the point at which the pressure is measured to within the peritoneum itself by way of communication through the separate flowpaths 101, 102. The dual lumen catheter 100 installs like a single lumen catheter, yet will function either as a flow through or a standard catheter. Both fluid pathways 101, 102 are used to withdraw and deliver fluid during the drain and fill. While one pathway delivers fluid, the other pathway drains. The end section, shown generally at 103, is perforated.

A comparison of an APD therapy for a prior art APD cyclers and one manufactured in accordance with the present invention are summarized as follows:

Therapy Parameter	Current APD Cycler	Cycler Using Invention
Total Therapy Volume	15 liters	15 liters
Fill Volume	2.2 liters	2.5 liters max
Fill Pressure Limit	not applicable	14 mm Hg max
Total Therapy Time	8 hours	8 hours
Last (Day) Fill Volume	1,500 ml	1,500 ml
Last Fill Dextrose	Same	Same
Initial Drain Alarm	1,200 ml	1,200 ml
Drain X of N Alarm	80%	80%

Table 1: Comparison of Therapies for Current Cyclers versus Cycler using Invention Method

	Therapy Phase	Therapy Parameter	Prior Art Cyclers 1	Prior Art Cyclers 2	Invention Cyclers 3
	Initial Drain	Drain Volume	1,200 ml	1,200 ml	1,200 ml
		Patient Volume	300 ml	300 ml	300 ml
5	Fill 1 of 5	Fill Volume	2,200 ml	2,200 ml	2,500 ml
		Patient Volume	2,500	2,500	2,800
		Fill Pressure	not applicable	not applicable	12 mm Hg
10	Drain 1 of 5	Drain Volume	1,800 ml	2,200 ml	2,200 ml
		Patient Volume	700 ml	300 ml	600 ml
	Fill 2 of 5	Fill Volume	2,200 ml	2,200 ml	2,400 ml
15		Patient Volume	2,900 ml	2,500 ml	3,000 ml
		Patient Pressure	not applicable	not applicable	14 mm Hg
	Drain 2 of 5	Drain Volume	1,800 ml	2,200 ml	2,200 ml
20		Patient Volume	1,100 ml	300 ml	800 ml
	Fill 3 of 5	Fill Volume	2,200 ml	2,200 ml	2,200 ml
		Patient Volume	3,300 ml	2,500 ml	3,000 ml
25		Patient Pressure	not applicable	not applicable	14 mm Hg
	Drain 3 of 5	Drain Volume	1,801 ml	2,200 ml	2,200 ml
		Patient Volume	1,499 ml	300 ml	800 ml
30	Fill 4 of 5	Fill Volume	2,200 ml	2,200 ml	2,200 ml
		Patient Volume	3,699 ml	2,500	3,000 ml
		Patient Pressure	not applicable	not applicable	3,000 ml
	Drain 4 of 5	Drain Volume	1,800 ml	2,200 ml	2,200 ml
		Patient Volume	1,899 ml	300 ml	800 ml
	Fill 5 of 5	Fill Volume	uF Alarm Bypass		
			2,200 ml	2,200 ml	2,200 ml
		Patient Volume	4,099 ml	2,500 ml	3,00 ml
		Patient Pressure	Patient Wakes Overfull, Manually Drains 1,500 ml	not applicable	14 mm Hg
	Drain 5 of 5	Drain Volume	1,800 ml	2,200 ml	2,200 ml
		Patient Volume	799 ml	300 ml	800 ml
	Final Fill	Fill Volume	1,500 ml	1,500 ml	1,500 ml

Inspection of Table 1 shows that cycler 1 woke the patient at around 4:30 in the morning with a negative uF alarm at the beginning of Fill 5. The patient bypassed the alarm because he did not feel overfull and immediately fell back asleep. He woke up about 15 minutes later when he had difficulty breathing and felt extremely overfull. He manually drained about 1500 ml but was unable to go back to sleep. He filed a formal product complaint with the manufacturer.

The data of Table 1 shows that cycler 2 ran a completely normal therapy but the total therapy clearance (calculated based upon the sum of the night patient volumes) was only 84.5% of that obtained by cycler 3, which was using the cycler that used the method of the current invention.

The data of Table 1 shows that cycler 3 ran a completely normal therapy and that the fill volume was limited on one occasion by the maximum fill volume but on four occasions by the patient's intraperitoneal pressure. This patient never felt any discomfort and had no alarms during the night. The limit on the IPP prevented him from being overfilled even though he had successive drains that were not complete. The volume of fluid in his peritoneum never exceeded 3 liters.

The patient on cycler 1 had an intraperitoneal pressure in excess of 14 mm Hg during dwells 3 and 4. His breathing may have been impaired and his heart may have had to work harder but the discomfort was not enough to wake him up from a sound sleep until it peaked at 4,099 ml during dwell 5.

In conclusion, the method of the present invention provides for optimum fills and therefore more clearance while preventing overfills that bring discomfort and inhibit the function of vital body organs. A negative uF alarm would seldom occur because overfills of the required magnitude would be prevented by the IPP sensors.

25 **Calculation of Intraperitoneal Pressure (IPP)**

In order to calculate the IPP, one may first calculate the patient head height correction using conservation of energy:

$$\Delta(1/2\rho V^2 + P - \rho_a g h) + \text{Frictional Losses} = 0$$

The velocity V of fluid through the patient line is the same at both ends of the line as is the fluid density, so this equation can be written as

$$(P_2 - P_1) - \rho_a g (h_2 - h_1) + \text{Frictional Losses} = 0$$

which can be rearranged as

$$\Delta h = \frac{(P_1 - P_2) - \text{Frictional Losses}}{\rho a_g}$$

5

Example 1

$$P_1 = 1.25 \text{ psig} = 85060 \text{ (gram/cm)/(cm}^2\text{-sec}^2\text{)}$$

$$P_2 = 0.9 \text{ psig} = 61240 \text{ (gram/cm)/(cm}^2\text{-sec}^2\text{)}$$

Frictional Losses = 39130 (gram/cm)/(cm²-sec²) with flow of 197 cmn/min in a

4 mm ID line at a velocity of approximately 172 cm/sec, wherein

10

$$a_g = 981 \text{ cm/sec}^2$$

$$\rho = 1 \text{ gram/cm}^3$$

15

$$\Delta h = \frac{((85060 - 61240) - 39130) \text{ (gram/cm)/(cm}^2\text{-sec}^2\text{)}}{1 \text{ gram/cm}^3 * 981 \text{ cm/sec}^2}$$

$\Delta h = -15.6 \text{ cm}$ (The patient is 15.6 cm below the membrane)

Example 2

$$P1 = 1.25 \text{ psig} = 85060 \text{ (gram/cm)/(cm}^2\text{-sec}^2\text{)}$$

$$P2 = 0.45 \text{ psig} = 30620 \text{ (gram/cm)/(cm}^2\text{-sec}^2\text{)}$$

Frictional Losses = 39130 (gram/cm)/(cm²-sec²) with flow of 197 cmn/min in a
 5 4 mm ID line at a velocity of approximately 172 cm/sec, wherein

$$a_g = 981 \text{ cm/sec}^2$$

$$\rho = 1 \text{ gram/cm}^3$$

$$10 \quad \Delta h = \frac{((85060-30620)-39130)(\text{gram/cm})/(\text{cm}^2\text{-sec}^2)}{1 \text{ gram/cm}^3 * 981 \text{ cm/sec}^2}$$

$$15 \quad \Delta h = +15.6 \text{ cm (The patient is 15.6 cm above the membrane)}$$

The patient head height can be established at the beginning of each fill. Any changes in the head height that occur during the fill can be attributed to an increase in intraperitoneal pressure (IPP) since the patient is asleep.

Turning to Figure 12, the concentration gradient between the urea concentration
 20 110 in the patient's blood and the urea concentration 111 in the dialysate for typical APD cyclers is illustrated graphically. Comparing the results illustrated in Figures 13 and 14, it is evident that APD cyclers equipped with the sensors of the present invention provide superior results. Specifically, the data illustrated graphically in Figure 13 was obtained using a prior art APD cycler. The data obtained in Figure 14 was obtained using an APD
 25 cycler utilizing two sensors for monitoring intraperitoneal pressure. Note that the urea concentration 110 in the bloodstream is lower in Figure 14 than in Figure 13. Further note, the dialysate volume or fill volume is lower for the therapy illustrated in Figure 14 than the therapy illustrated in Figure 13. Thus, the present invention provides improved urea clearance with lower fill volumes.

30 It should be understood that various changes and modifications to the presently preferred embodiments described herein will be apparent to those skilled in the art. Such changes and modifications may be made without departing from the spirit and scope of the present invention and without diminishing its attendant advantages. It is, therefore, intended that such changes and modifications be covered by the appended claims.

35

WE CLAIM:

1. A system for providing peritoneal dialysis to a patient, the system comprising:
 - a dialysate container connected to the patient with a first pressure sensor
 - 5 connected in-line therebetween, and
 - a drain container connected to the patient with a second pressure sensor connected in-line therebetween.
2. The system of claim 1 further comprising a first pump disposed in-line
10 between the dialysate container and the first pressure sensor.
3. The system of claim 1 wherein the dialysate flows from the dialysate container into the patient under a hydrostatic head.
4. The system of claim 1 further comprising a second pump disposed in-line
15 between the drain container and the second pressure sensor.
5. The system of claim 1 wherein the dialysate flows from the patient to the drain container under a hydrostatic head.
20
6. The system of claim 1 wherein the second pressure sensor measures an intraperitoneal pressure of the patient while dialysate flows from the dialysate container to the patient.
7. The system of claim 1 wherein the first pressure sensor measures an intraperitoneal pressure of the patient while dialysate flows from the patient to the drain container.
25
8. The system of claim 1 further comprising a first lumen connecting the
30 dialysate container to the first sensor and the first sensor to a catheter, and

a second lumen connecting the drain container to the second sensor and the second sensor to the catheter,

the catheter being connected to the patient,

a flow of dialysate from the patient to the drain container evacuating dialysate
5 from the first lumen and causing said dialysate from the first lumen to flow through the second lumen and to the drain container.

9. The system of claim 8 wherein the catheter is a dual lumen catheter.

10 10. The system of claim 1 wherein the first and second sensors are redundant in-line pressure/vacuum sensors.

11. A system for providing peritoneal dialysis to a patient, the system comprising:

15 a dialysate container connected to the patient with a first pump and a first pressure sensor connected in-line therebetween, the first sensor being disposed between the first pump and patient, and

a drain container connected to the patient with a second pump and a second pressure sensor connected in-line therebetween, the second sensor disposed between the
20 second pump and the patient.

12. The system of claim 11 wherein the second pressure sensor measures an intraperitoneal pressure of the patient while dialysate is pumped by the first pump from the dialysate container to the patient.

25

13. The system of claim 11 wherein the first pressure sensor measures an intraperitoneal pressure of the patient while dialysate is pumped by the second pump from the patient to the drain container.

14. The system of claim 11 further comprising a first lumen connecting the dialysate container to the first pump and the first pump to the first sensor and the first sensor to a catheter, and

5 a second lumen connecting the drain container to the second pump and the second pump to the second sensor and the second sensor to the catheter,
the catheter being connected to the patient,
operation of the second pump evacuating dialysate from the first lumen and pumping said dialysate from the first lumen to the drain container.

10 15. The system of claim 14 wherein the catheter is a dual lumen catheter.

16. The system of claim 11 wherein the first and second sensors are redundant in-line pressure/vacuum sensors.

15 17. A method of dialyzing a patient comprising the steps of:
placing a catheter in a peritoneum of the patient;
providing at least one dialysate container;
connecting the dialysate container to the catheter with a first lumen that includes
a first pressure sensor disposed in-line and between the catheter and the dialysate
20 container;
providing at least one drain container;
connecting the drain container to the catheter with a second lumen that includes
a second pressure sensor disposed in-line and between the catheter and the drain
container;
25 transferring dialysate from the dialysate container to the peritoneum of the patient
and monitoring an intraperitoneal pressure of the patient with the second pressure sensor;
transferring dialysate from the peritoneum of the patient to the drain container and
monitoring the intraperitoneal pressure of the patient with the first pressure sensor.

30 18. The method of claim 17 wherein the step of transferring dialysate from the dialysate container to the peritoneum of the patient further comprises pumping

dialysate from the dialysate container to the patient with a first pump disposed in-line between the dialysate container and the first pressure sensor.

19. The method of claim 17 wherein the step of transferring dialysate from
5 the peritoneum of the patient to the drain container further comprises pumping dialysate from the peritoneum of the patient to the drain container with a second pump disposed in-line between the drain container and the second pressure sensor.

20. The method of claim 17 wherein the dialysate container is disposed
10 vertically above the peritoneum of the patient and the step of transferring dialysate from the dialysate container to the peritoneum of the patient further comprises flowing dialysate from the dialysate container to the patient under a hydrostatic head.

21. The method of claim 17 wherein the drain container is disposed vertically
15 below the peritoneum of the patient and the step of transferring dialysate from the peritoneum of the patient to the drain container further comprises flowing dialysate from the peritoneum of the patient to the drain container under a hydrostatic head.

FIG.1
(PRIOR ART)

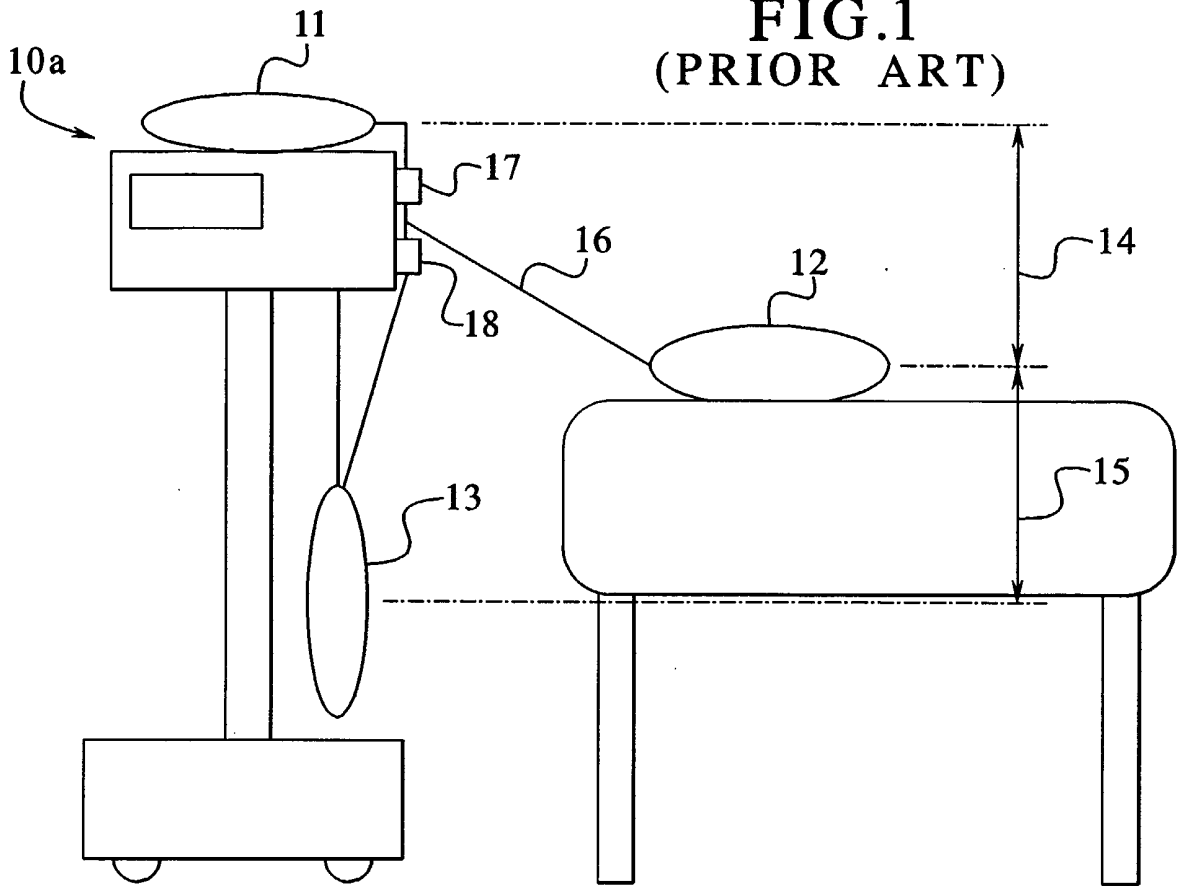
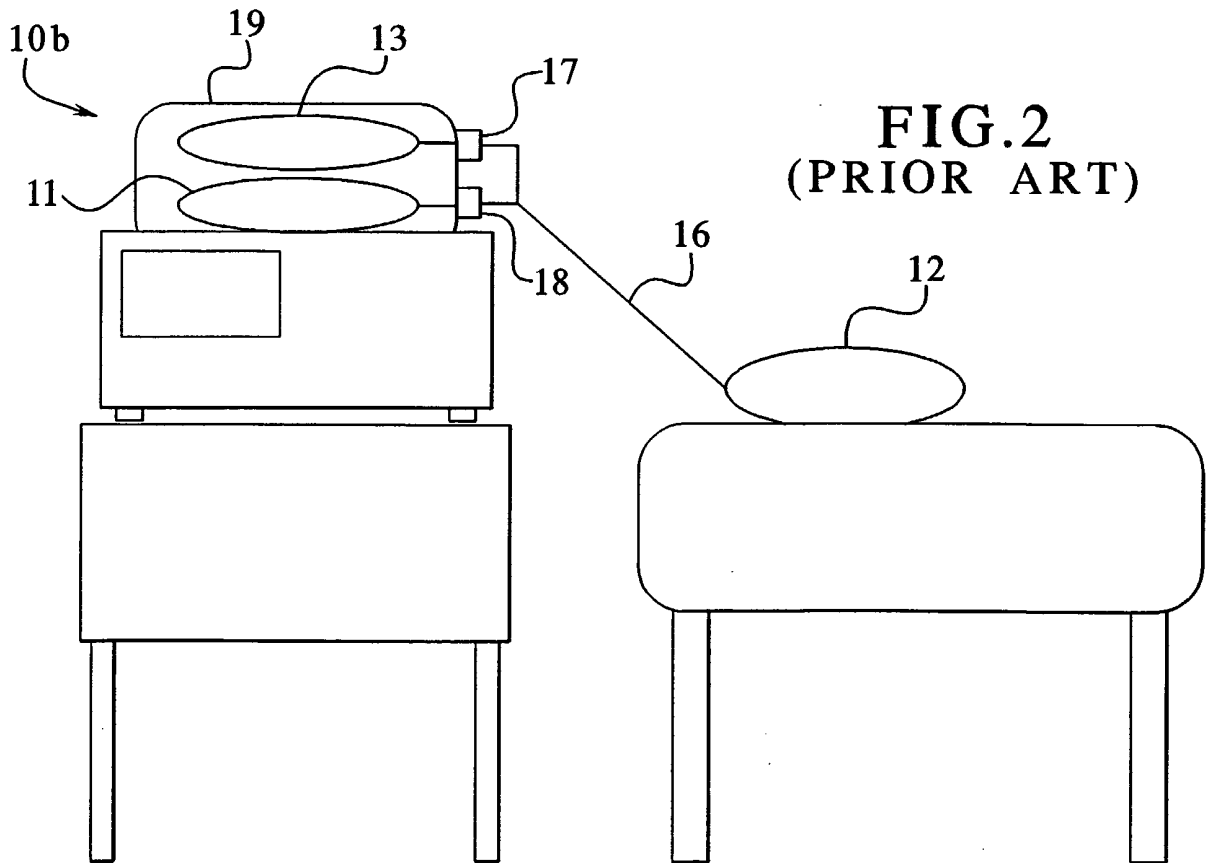
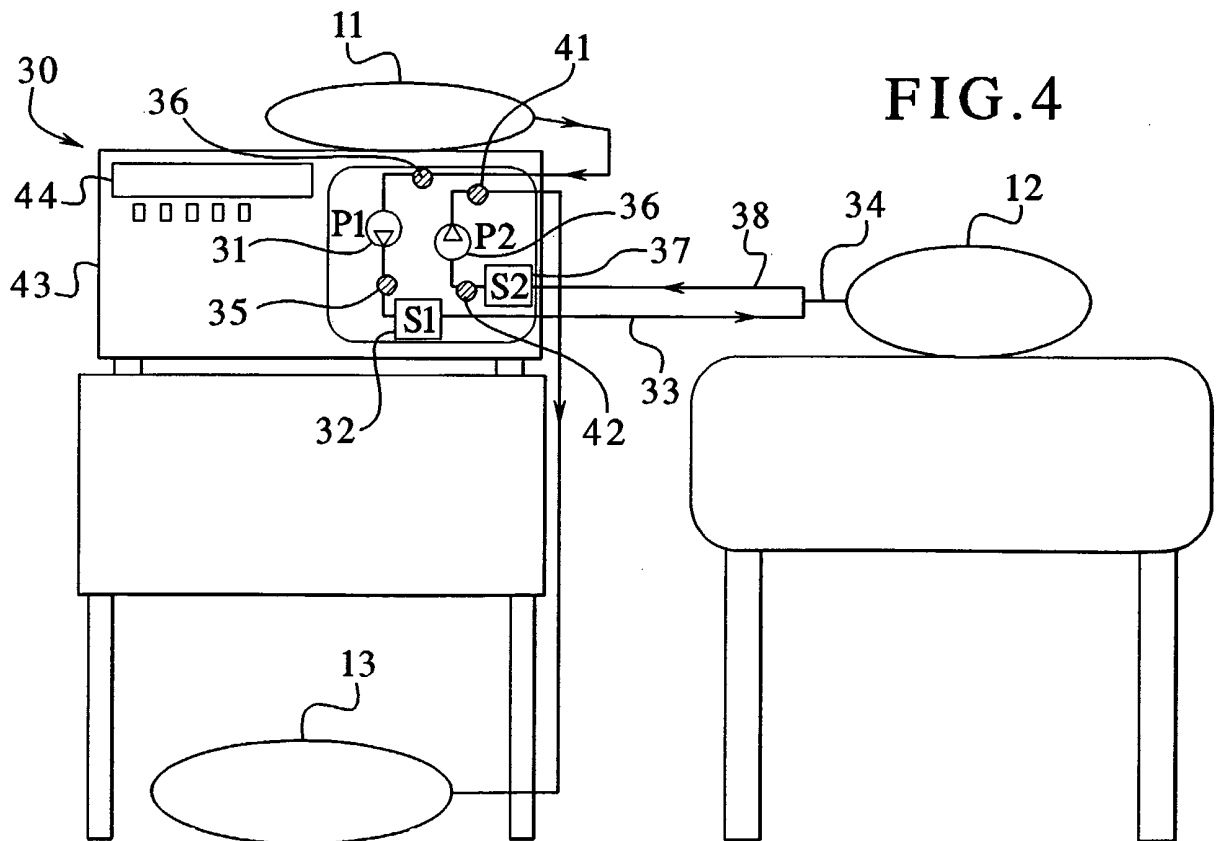
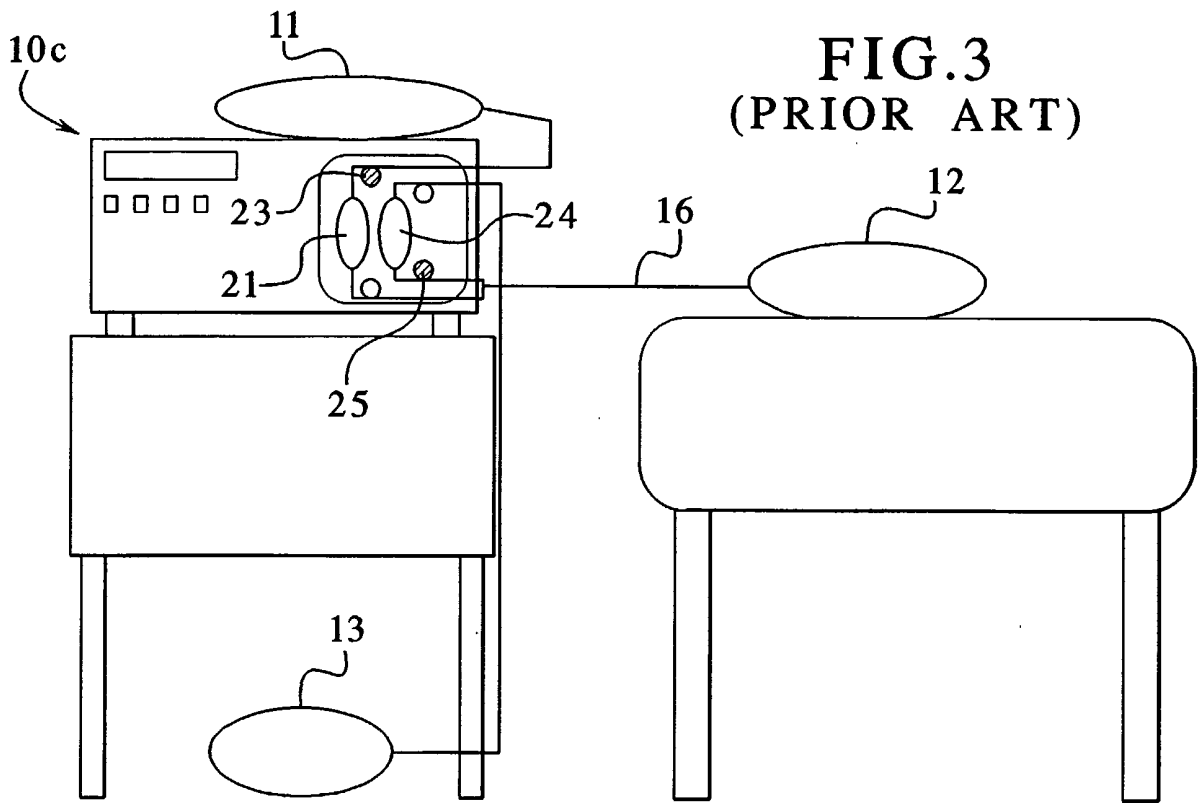

FIG.2
(PRIOR ART)





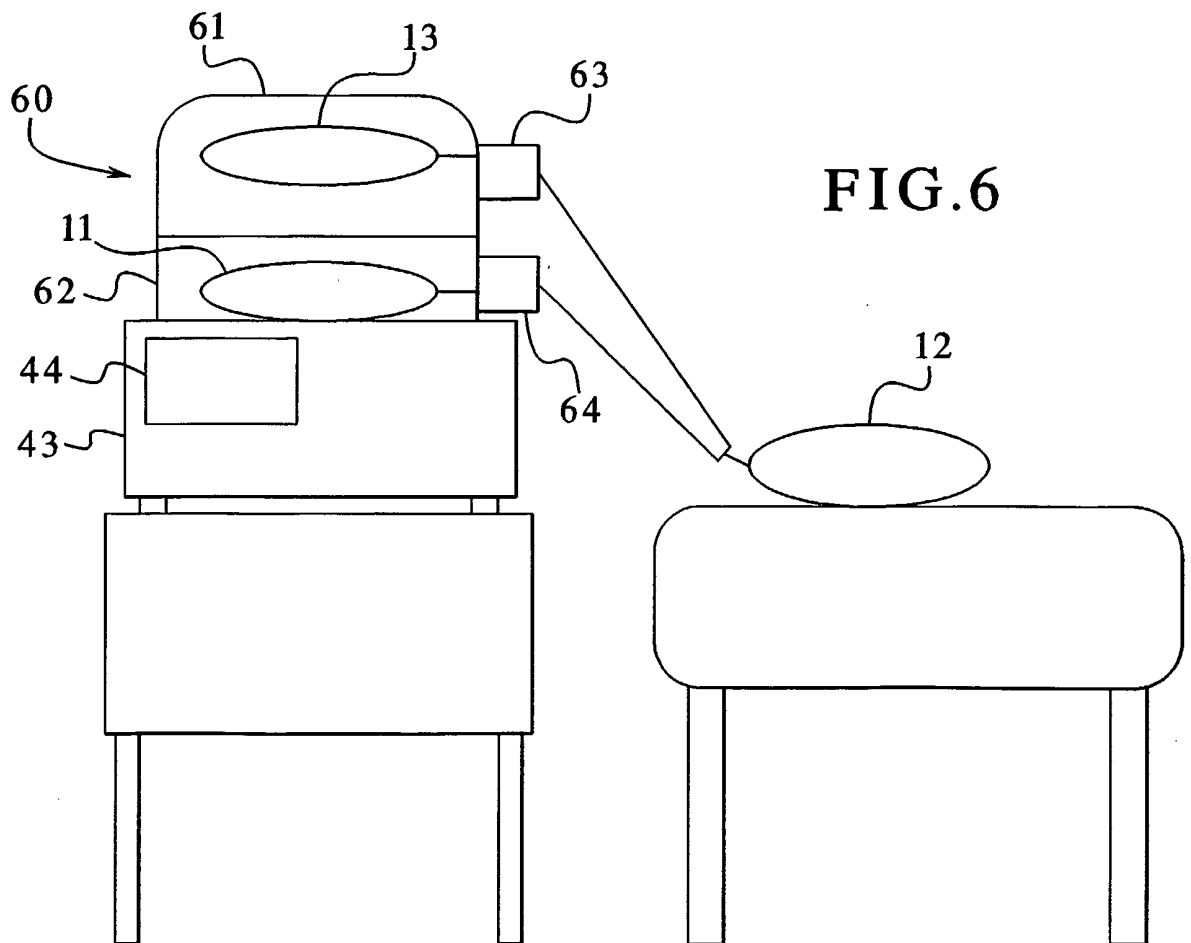
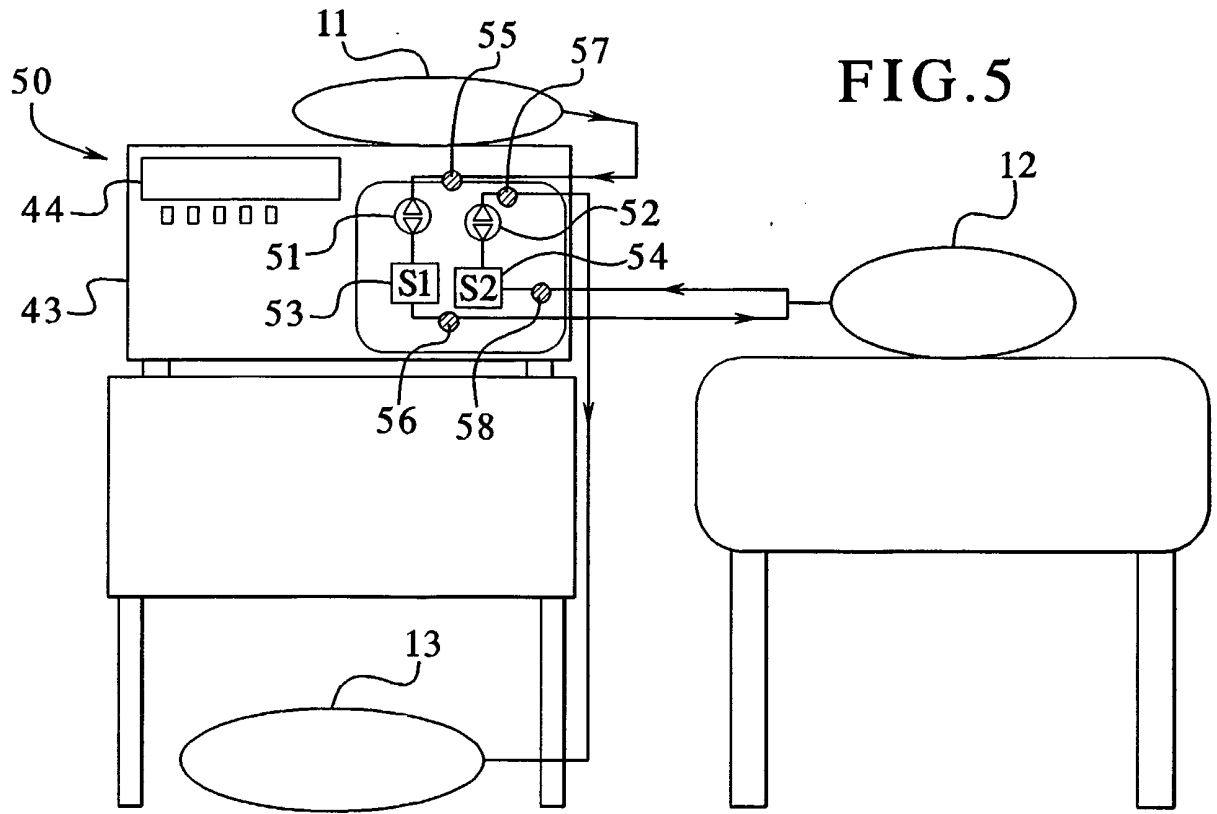

FIG. 7

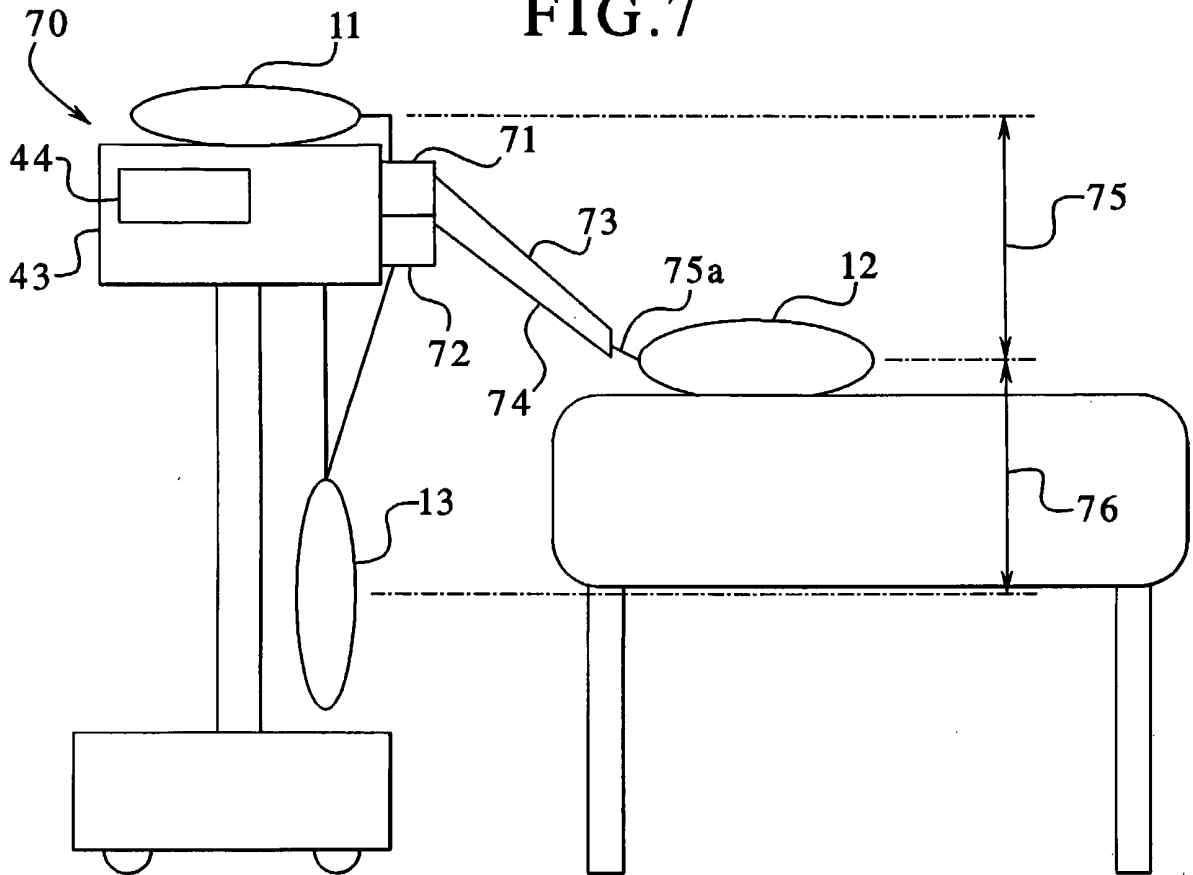

FIG. 8

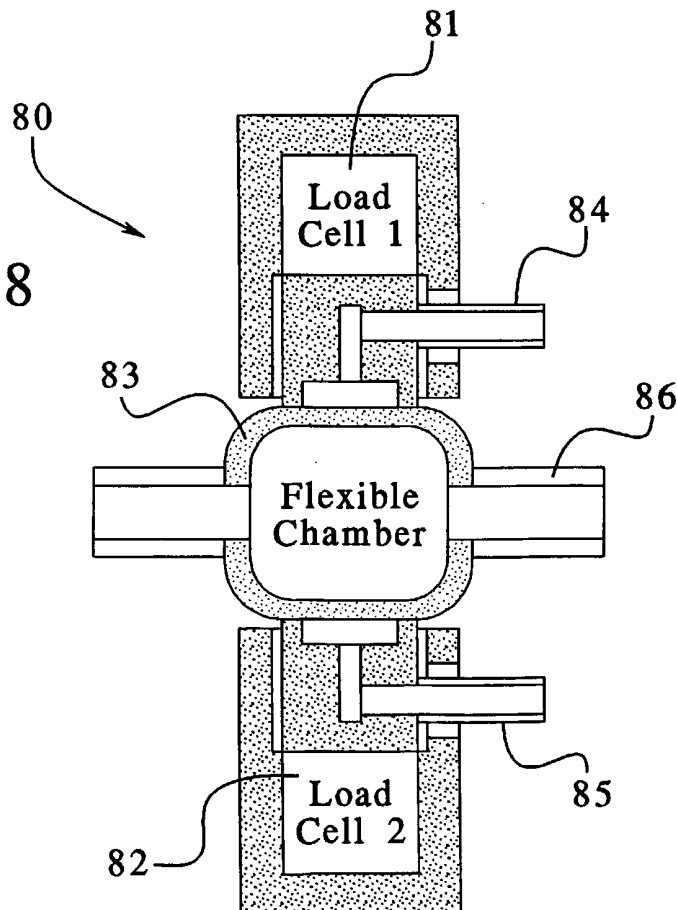

FIG. 9

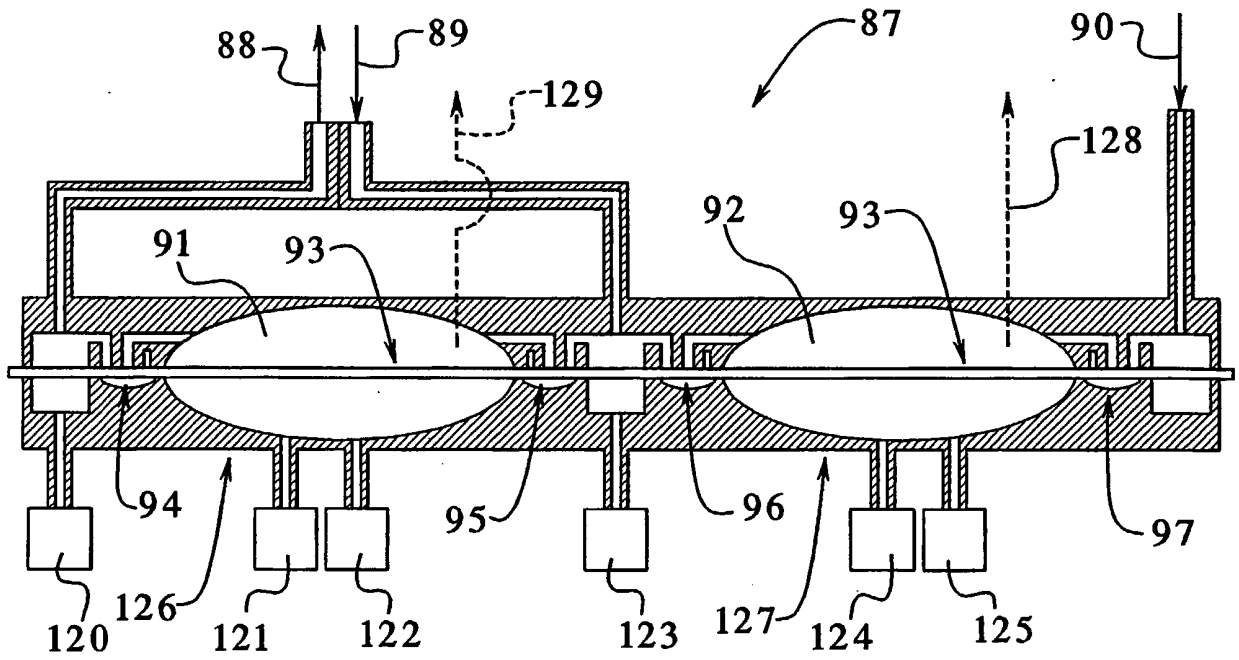

FIG. 10

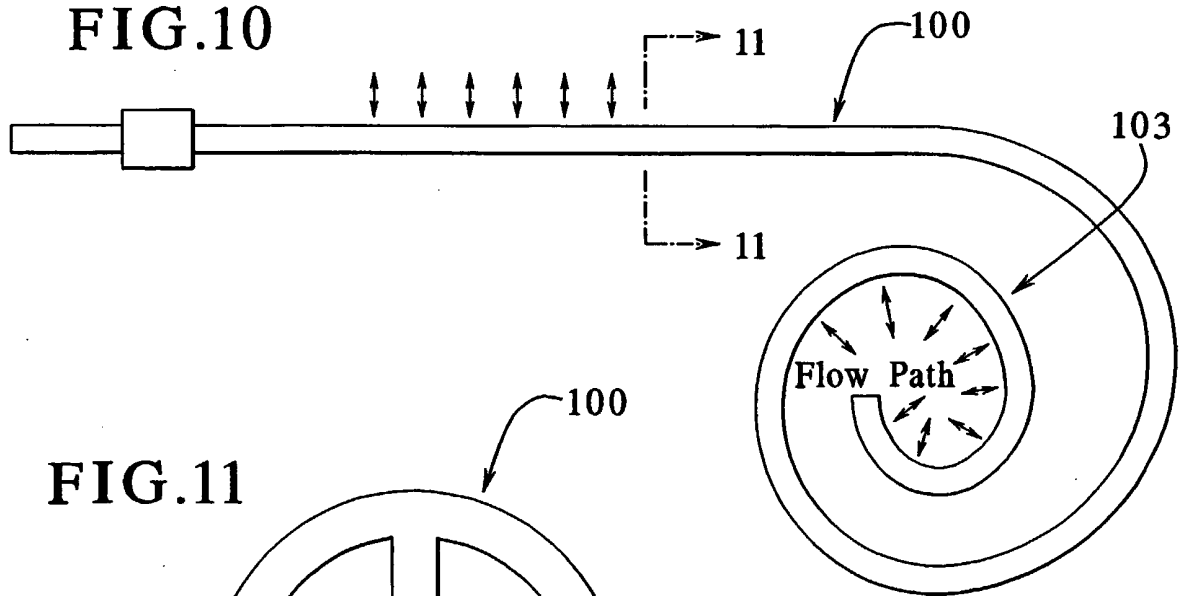

FIG. 11

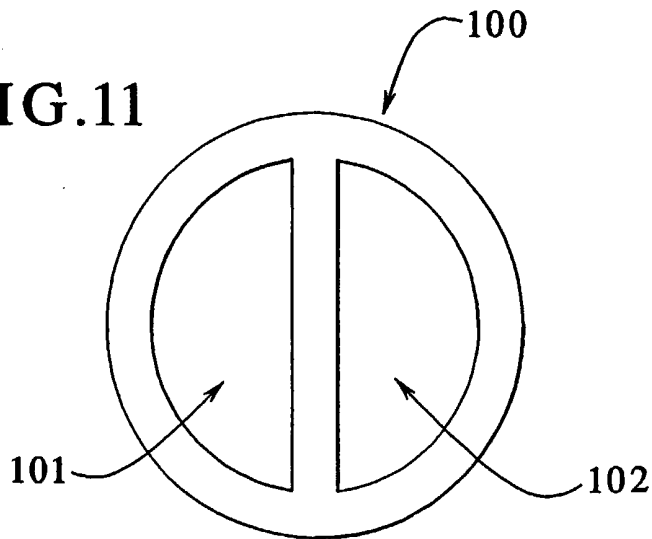

FIG.12

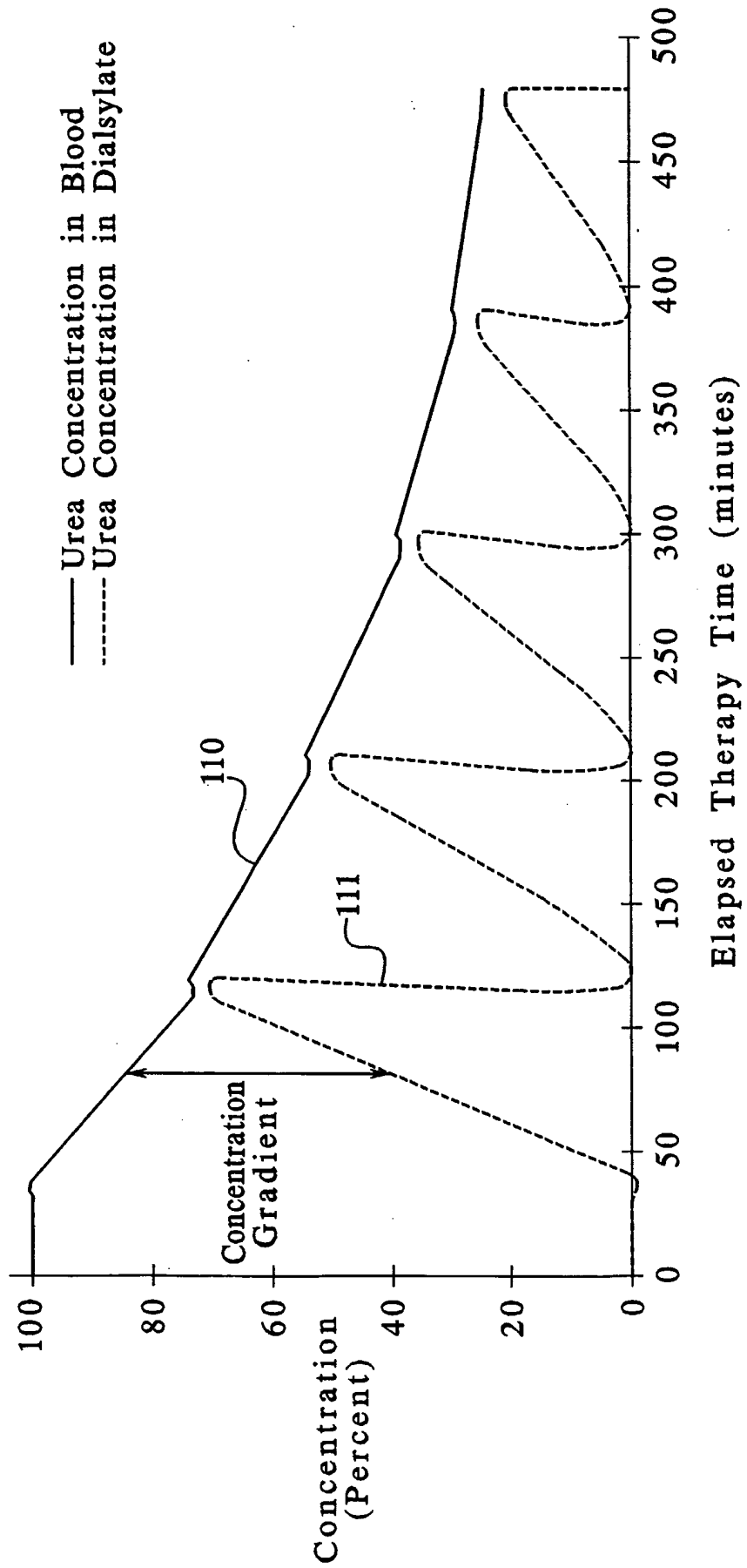

FIG.13

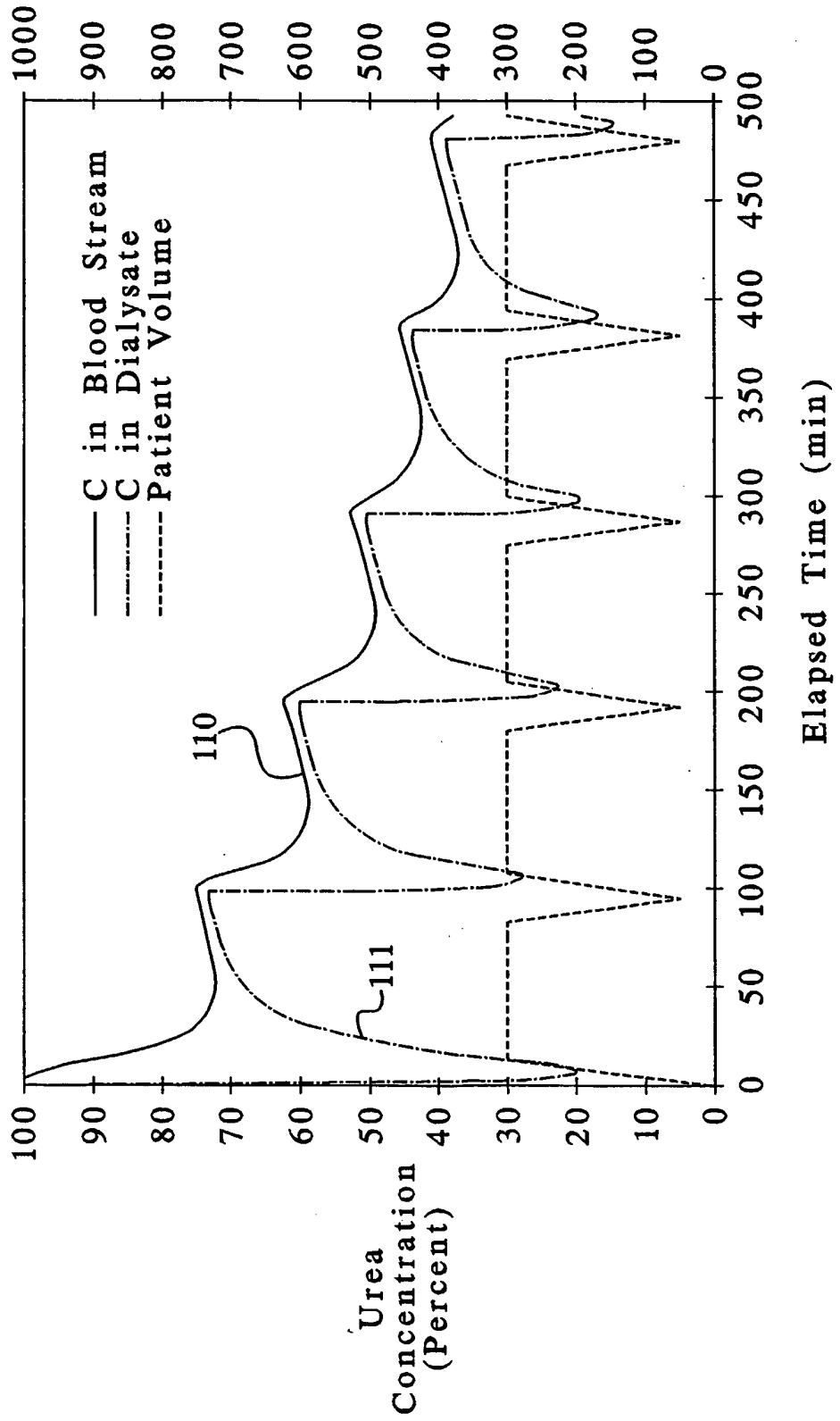
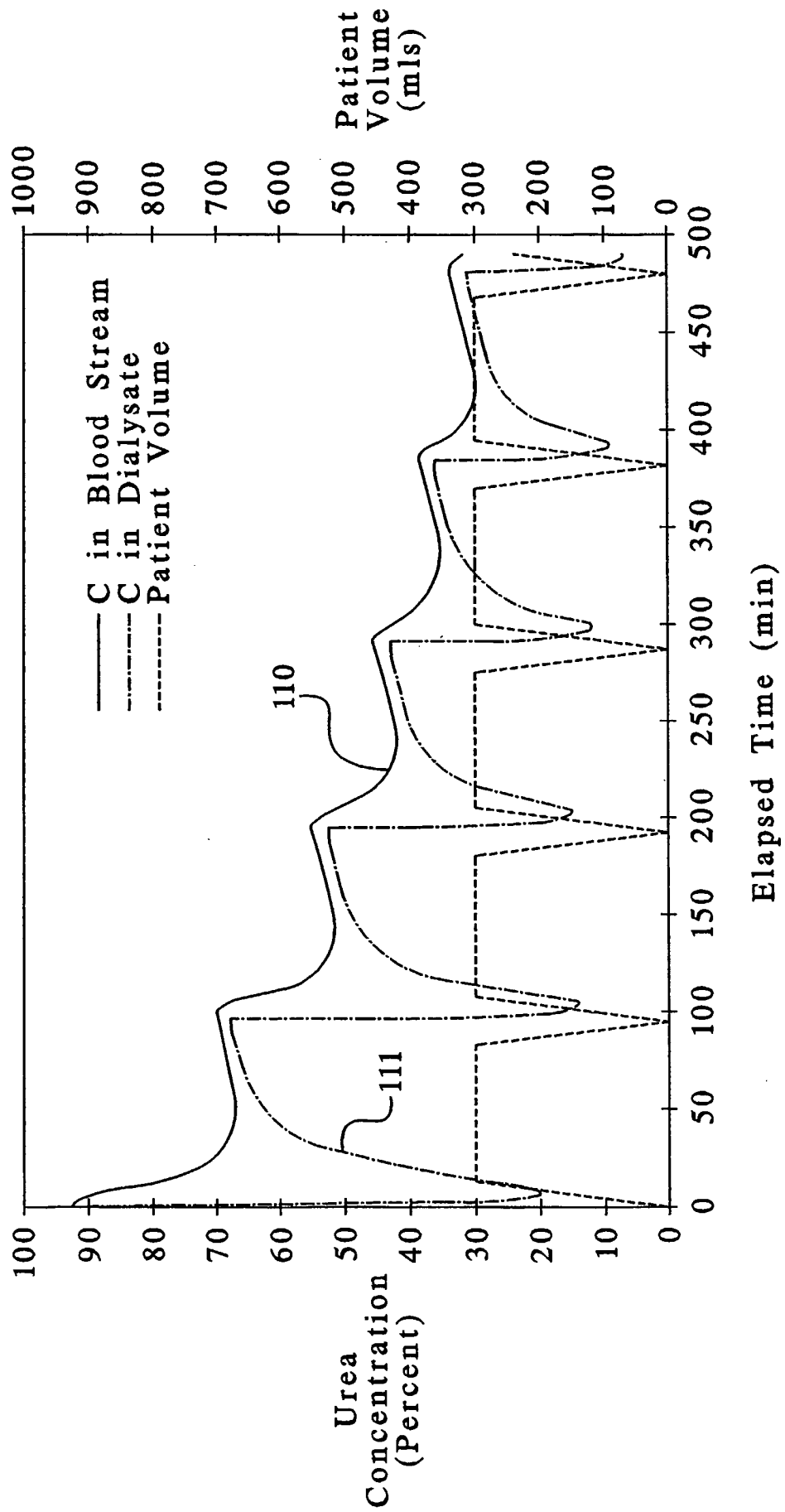

FIG.14



INTERNATIONAL SEARCH REPORT

International Application No

PCT/US 01/04083

A. CLASSIFICATION OF SUBJECT MATTER

IPC 7 A61M1/28

According to International Patent Classification (IPC) or to both national classification and IPC

B. FIELDS SEARCHED

Minimum documentation searched (classification system followed by classification symbols)

IPC 7 A61M

Documentation searched other than minimum documentation to the extent that such documents are included in the fields searched

Electronic data base consulted during the international search (name of data base and, where practical, search terms used)

EPO-Internal, WPI Data, PAJ

C. DOCUMENTS CONSIDERED TO BE RELEVANT

Category °	Citation of document, with indication, where appropriate, of the relevant passages	Relevant to claim No.
X	WO 98 50088 A (TRANSVIVO INC) 12 November 1998 (1998-11-12) page 3, line 19 - line 22 page 3, line 34 -page 4, line 3 figure 1	1-16
X	US 5 141 493 A (HANOVER BARRY K ET AL) 25 August 1992 (1992-08-25) column 3, line 21 - line 61 figure 1A	1-3,5-9
X	US 4 586 920 A (PEABODY ALAN M) 6 May 1986 (1986-05-06) column 4, line 9 - line 55 column 6, line 4 - line 5 figure 2	1-9, 11-15
	-/--	

 Further documents are listed in the continuation of box C. Patent family members are listed in annex.

° Special categories of cited documents :

- *A* document defining the general state of the art which is not considered to be of particular relevance
- *E* earlier document but published on or after the international filing date
- *L* document which may throw doubts on priority claim(s) or which is cited to establish the publication date of another citation or other special reason (as specified)
- *O* document referring to an oral disclosure, use, exhibition or other means
- *P* document published prior to the international filing date but later than the priority date claimed

- *T* later document published after the international filing date or priority date and not in conflict with the application but cited to understand the principle or theory underlying the invention
- *X* document of particular relevance; the claimed invention cannot be considered novel or cannot be considered to involve an inventive step when the document is taken alone
- *Y* document of particular relevance; the claimed invention cannot be considered to involve an inventive step when the document is combined with one or more other such documents, such combination being obvious to a person skilled in the art.
- *Z* document member of the same patent family

Date of the actual completion of the international search

18 July 2001

Date of mailing of the international search report

24/07/2001

Name and mailing address of the ISA

European Patent Office, P.B. 5818 Patentlaan 2
NL - 2280 HV Rijswijk
Tel. (+31-70) 340-2040, Tx. 31 651 epo nl,
Fax: (+31-70) 340-3016

Authorized officer

Lakkis, A

INTERNATIONAL SEARCH REPORT

 International Application No
 PCT/US 01/04083

C.(Continuation) DOCUMENTS CONSIDERED TO BE RELEVANT

Category °	Citation of document, with indication, where appropriate, of the relevant passages	Relevant to claim No.
A	WO 99 06082 A (DADSON JOSEPH E) 11 February 1999 (1999-02-11) page 2, last paragraph page 5, paragraph 1 page 6, paragraph 5 page 7, paragraph 3 page 15, paragraph 2 figures 1,4 ---	1-16
A	US 5 004 459 A (MORTON HENRY H ET AL) 2 April 1991 (1991-04-02) abstract; figure 1 ---	1-16
A	WO 95 35124 A (BAXTER INT) 28 December 1995 (1995-12-28) page 8, line 25 - line 32; figure 4 ---	1-16
A	US 4 338 190 A (KRAUS MENAHEM A ET AL) 6 July 1982 (1982-07-06) column 3, line 3 - line 20; figure 1 -----	1-16

INTERNATIONAL SEARCH REPORT

Information on patent family members

International Application No

PCT/US 01/04083

Patent document cited in search report		Publication date	Patent family member(s)	Publication date
WO 9850088	A	12-11-1998	US 5980481 A AU 6890798 A US 6234991 B	09-11-1999 27-11-1998 22-05-2001
US 5141493	A	25-08-1992	NONE	
US 4586920	A	06-05-1986	EP 0243547 A US 5004459 A US 5643201 A US 4718890 A US 4747822 A AT 65416 T DE 3680526 D	04-11-1987 02-04-1991 01-07-1997 12-01-1988 31-05-1988 15-08-1991 29-08-1991
WO 9906082	A	11-02-1999	AU 8525798 A CN 1273535 T EP 0999862 A US 6228047 B	22-02-1999 15-11-2000 17-05-2000 08-05-2001
US 5004459	A	02-04-1991	US 4586920 A US 4718890 A US 4747822 A JP 2049662 A JP 2921857 B US 5643201 A	06-05-1986 12-01-1988 31-05-1988 20-02-1990 19-07-1999 01-07-1997
WO 9535124	A	28-12-1995	AU 688062 B AU 2763195 A CA 2167276 A EP 0714312 A JP 9501862 T US 5641405 A	05-03-1998 15-01-1996 28-12-1995 05-06-1996 25-02-1997 24-06-1997
US 4338190	A	06-07-1982	IL 49031 A JP 52115598 A	30-11-1979 28-09-1977