

April 25, 1939.

A. J. ALBERTS

2,155,920

HEADING AND TRIMMING MACHINE

Original Filed May 10, 1937

5 Sheets-Sheet 1

Fig. 1.

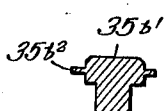
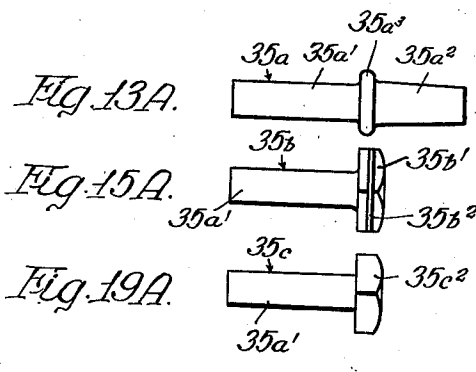
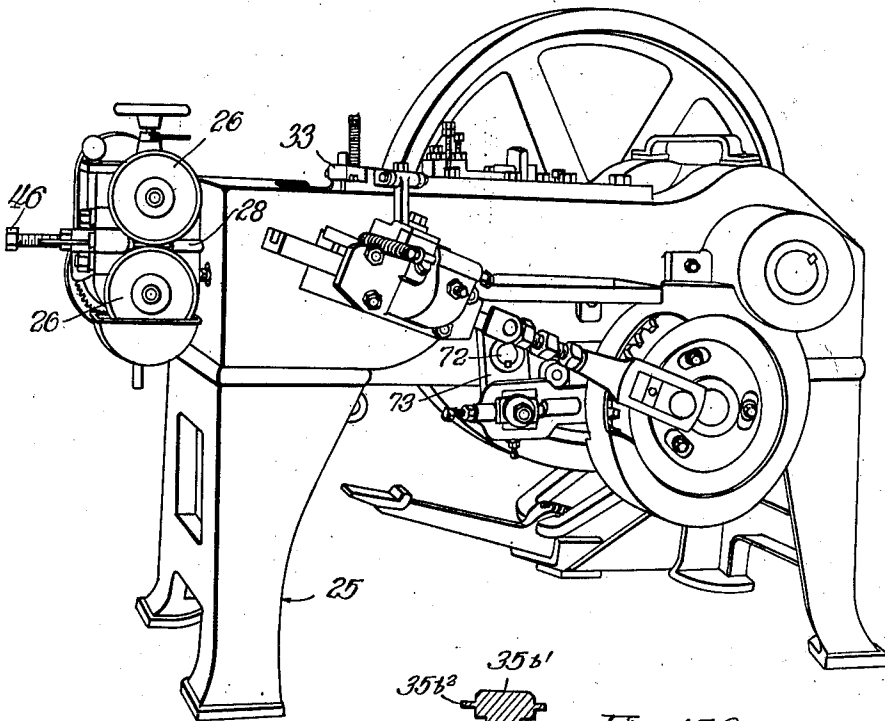

Fig. 15C.

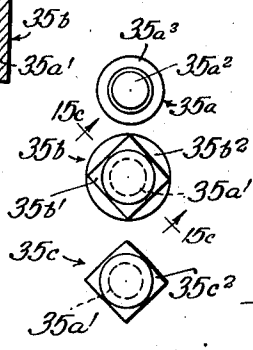

Fig. 13B.

Fig. 15B.

Fig. 19B.

Inventor

Arthur J. Alberts

By *Mountjoy & Boucher*
Brewer

Attorneys

April 25, 1939.

A. J. ALBERTS

2,155,920

HEADING AND TRIMMING MACHINE

Original Filed May 10, 1937

5 Sheets-Sheet 2

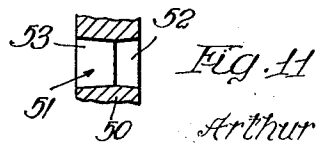
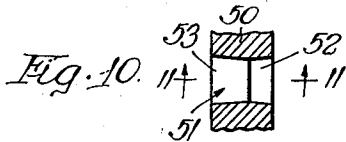
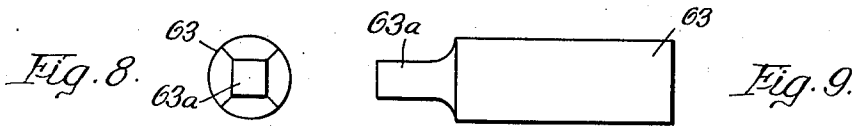
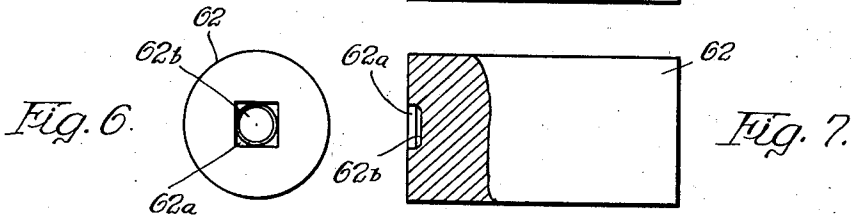
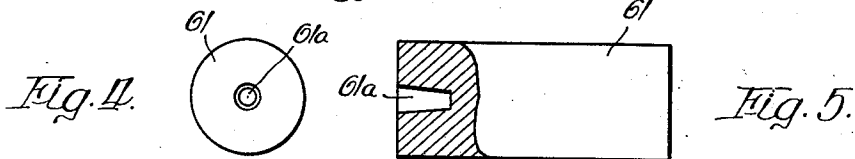
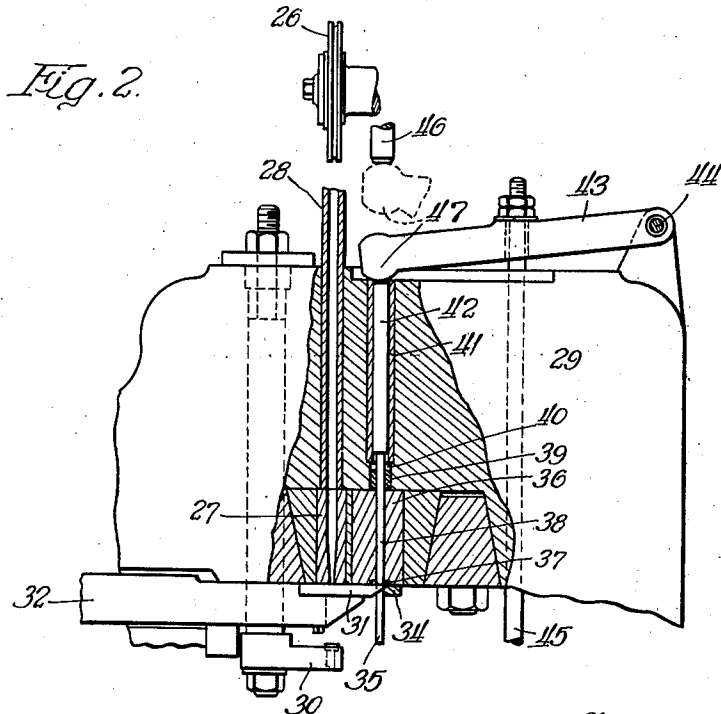

Inventor

Arthur J. Alberts

By *Arthur J. Alberts*
Attorneys

Attorneys

April 25, 1939.

A. J. ALBERTS

2,155,920

HEADING AND TRIMMING MACHINE

Original Filed May 10, 1937

5 Sheets-Sheet 3

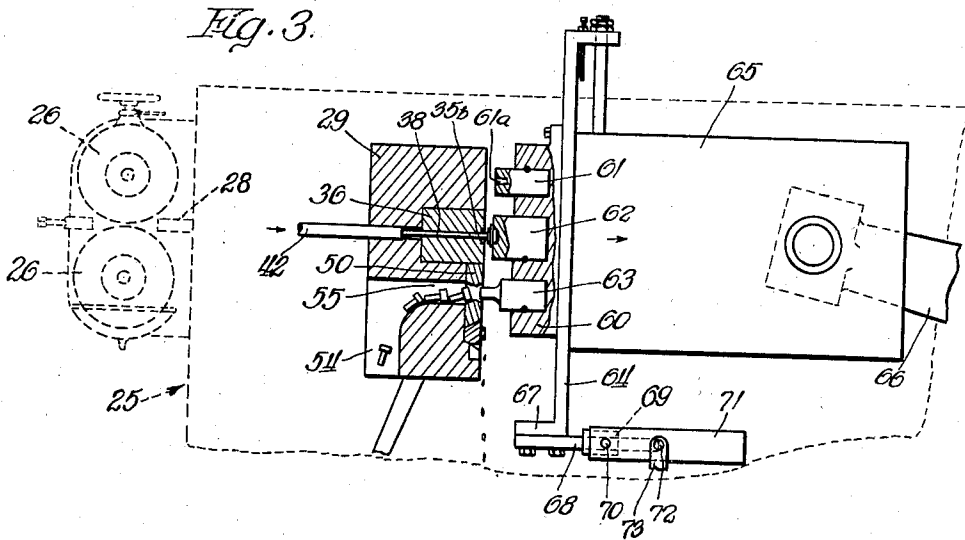

Fig. 12.

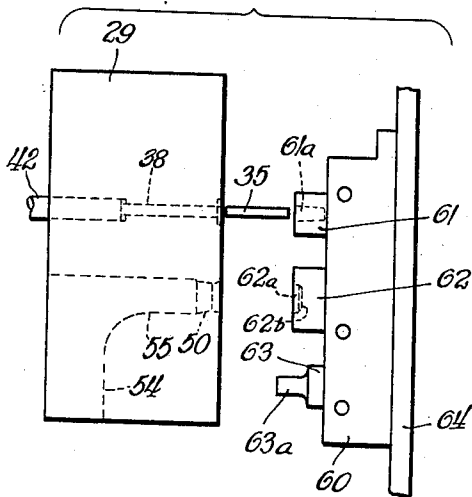
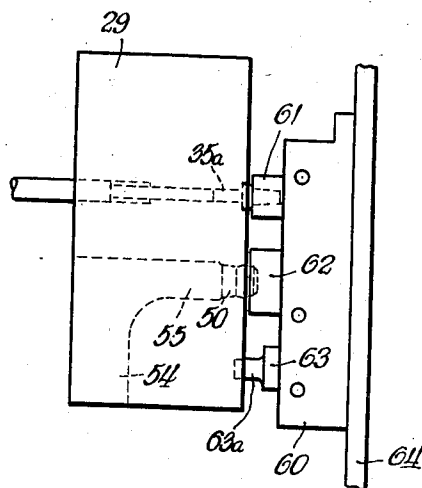

Fig. 13.



Inventor

Arthur J. Alberts

By *Manufacturers Building*
Decor.

Attorneys

April 25, 1939.

A. J. ALBERTS

2,155,920

HEADING AND TRIMMING MACHINE

Original Filed May 10, 1937

5 Sheets-Sheet 4

Fig. 14.

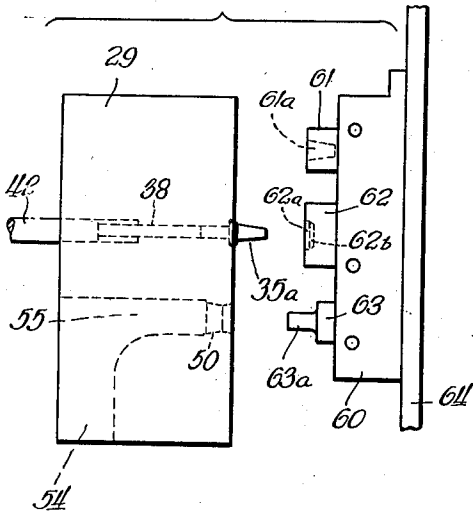

Fig. 15.

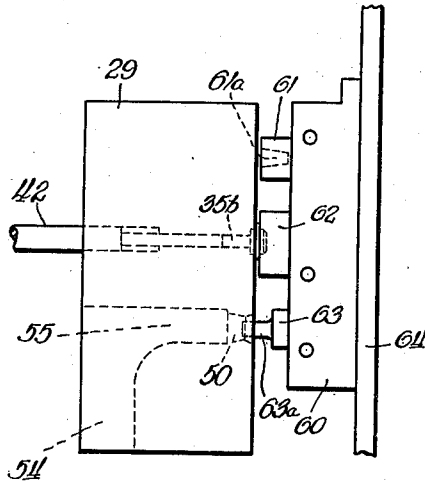

Fig. 16.

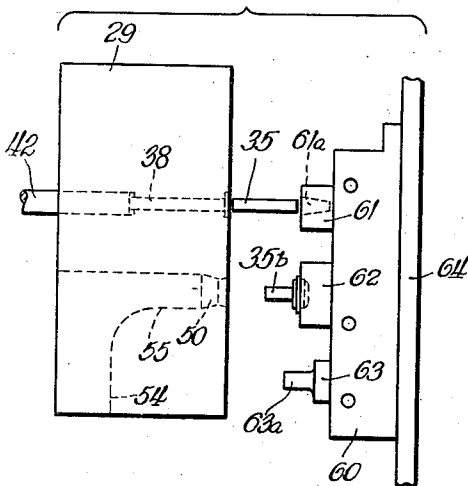
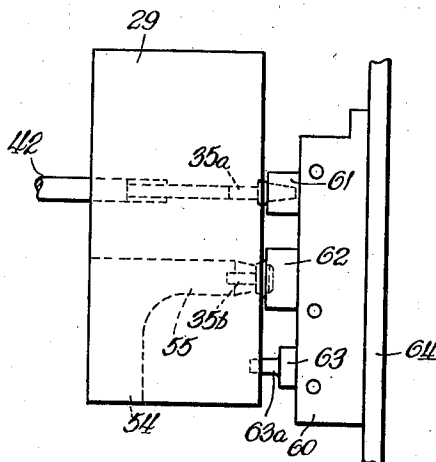

Fig. 17.



Inventor

Arthur J. Alberts

By *Murphy Jacobson* &
Bochner
Attorneys

Attorneys

April 25, 1939.

A. J. ALBERTS

2,155,920

HEADING AND TRIMMING MACHINE

Original Filed May 10, 1937

5 Sheets-Sheet 5

Fig. 18.

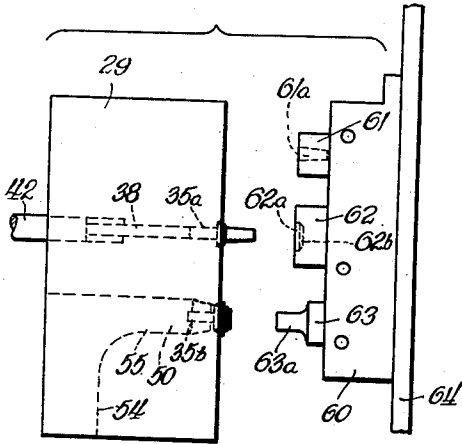

Fig. 19.

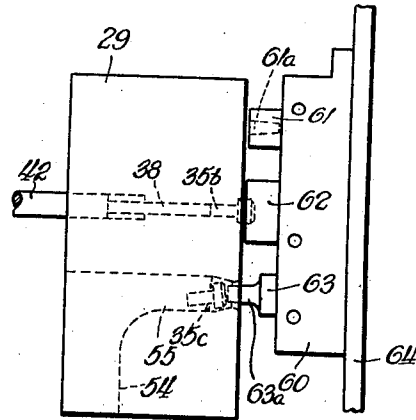

Fig. 20.

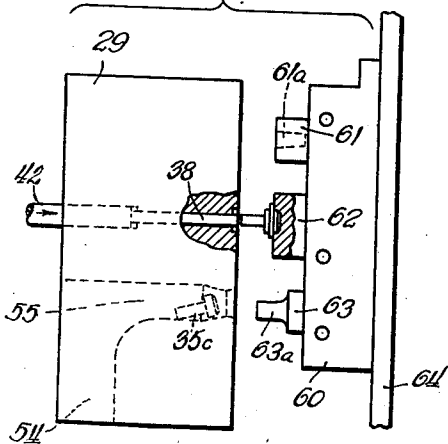

Fig. 21.

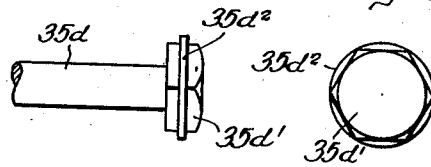

Fig. 22.

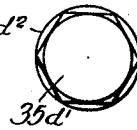

Fig. 23.

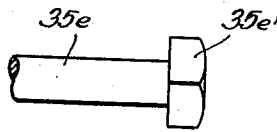

Fig. 24.



Inventor

Arthur J. Alberts

By *Proctor, Jensen & Bostwick*

Attorneys

UNITED STATES PATENT OFFICE

2,155,920

HEADING AND TRIMMING MACHINE

Arthur J. Alberts, Chicago, Ill.

Original application May 10, 1937, Serial No. 141,641, now Patent No. 2,124,022, dated July 19, 1938. Divided and this application May 11, 1938, Serial No. 207,233

7 Claims. (Cl. 10—12)

This invention relates to the production of headed bolt blanks and similar articles, and has to do with a machine for producing such articles.

It is the present practice in producing headed bolt blanks to cut the wire or stock in appropriate lengths, form upon one end of the blank thus produced a substantially cylindrical head of the proper thickness and diameter for producing a desired head, these operations being performed in a heading machine, after which the blank is passed through a trimming machine which trims the substantially cylindrical head to the final size and shape of the desired head. Under the present practice referred to, the use of a heading machine and a trimming machine is necessary.

My invention is directed to the provision of means whereby the heading and trimming operations are performed in one machine, thus eliminating the use of a separate trimming machine with corresponding reduced cost of production, an important consideration in this art. The method of operation of my machine comprises upsetting an end portion of a blank and simultaneously partially forming thereupon a head of the desired shape and size, forming the remainder of the upset portion to the desired shape and size of the head, thus completing the head with a relatively thin fin of flash metal extending about the head between the inner and the outer faces thereof, upsetting the end portion of a second blank while inserting the head of the first blank into a trimming die, and driving the head of the first blank through the trimming die trimming off the fin of flash metal, thus completing the head of the first blank, while forming the head of the second blank to the desired size and shape. The machine comprises means whereby the successive steps of the operation are performed in proper sequence such that during the upsetting and partial forming of the head on a second blank a first blank, upon which a head with a fin of flash metal extending thereabout has previously been formed, is inserted into the trimming die, this first blank being forced through the trimming die during the succeeding step of completing the formation of the head upon the second blank, which is conducive to high speed operation with resulting increased output of the machine. I provide improved heading and trimming dies and punches and associated hammer and die blocks, which may be applied with expedition and facility to heading machines of known type without necessitating material changes therein. Further ob-

jects and advantages will appear from the detailed description.

In the drawings:

Figure 1 is an isometric side view of a heading machine of known type having applied thereto the heading and trimming means of my invention whereby such machine is rendered capable of heading and trimming bolts in accordance with the method of my invention;

Figure 2 is a fragmentary plan view, on an enlarged scale, of the die block and associated parts of the machine of Figure 1, certain parts being broken away and shown in section;

Figure 3 is a semi-diagrammatic vertical sectional view through the die and hammer blocks of the machine, showing the relation of the blocks and associated parts just after completion of the heading and trimming operations, adjacent parts being shown in elevation, certain parts being shown partly in elevation and partly in section, certain other parts of the machine being indicated in dotted lines;

Figure 4 is an inner end view of the upsetting or coning punch, on an enlarged scale;

Figure 5 is a side view, partly broken away and in section, of the coning punch;

Figure 6 is an inner end view, on an enlarged scale, of the heading punch;

Figure 7 is a side view, partly broken away and in section, of the heading punch of Figure 6;

Figure 8 is an inner end view, on an enlarged scale, of the trimming punch;

Figure 9 is a side view of the trimming punch of Figure 8;

Figure 10 is a vertical sectional view, on an enlarged scale, through the trimming die;

Figure 11 is a section taken substantially on line 11—11 of Figure 10;

Figures 12 to 19, inclusive, are semi-diagrammatic views of the die and hammer blocks and associated parts illustrating the successive steps in the operation of heading and trimming a blank;

Figure 20 is a semi-diagrammatic view, partly broken away and in section, of the die and hammer blocks illustrating the manner in which a headed blank is ejected from the die block in the movement of the hammer block away from the die block after completion of the second step in the heading operation;

Figure 13A is a side view, to full scale, of a partly headed blank produced by the first step of the operation illustrated in Figure 13;

Figure 13B is an end view, as seen from the head end, of the blank of Figure 13A;

Figure 15A is a side view, to full scale, of the headed blank produced by the second step of the heading operation illustrated in Figure 15;

Figure 15B is an end view, from the head end, of the headed blank of Figure 15A;

Figure 15C is a sectional view taken substantially on line 15c—15c of Figure 15B;

Figure 19A is a side view, to full scale, of the headed blank of Figure 15A after trimming of the flash metal therefrom by the step of the operation illustrated in Figure 19;

Figure 19B is an end view, from the headed end thereof, of the headed and trimmed blank of Figure 19A;

Figure 21 is a view similar to Figure 15A, on an enlarged scale, of a blank having a hexagonal head formed thereon;

Figure 22 is an end view, from the head end, of the blank of Figure 21;

Figure 23 is a side view of the blank of Figure 21 after the flash metal has been trimmed from the head thereof; and

Figure 24 is an end view, from the head end, of the blank of Figure 23.

This application is a division of my copending application for Heading method, Serial No. 141,641, filed May 10, 1937.

I have illustrated the heading and trimming means of my invention, by way of example, as applied to a heading machine known as the No. 2 Manville header, made by the E. J. Manville Machine Company of Waterbury, Connecticut. It will be understood, however, that the heading and trimming means of my invention may, within the broader aspects thereof, be applied to any other suitable heading machine.

Heading machines of the type illustrated in Figure 1 are well known in the art, are of known construction and operation and need not be illustrated nor described in detail. Briefly, this machine comprises a reciprocating ram carrying a hammer block mounted on a transfer slide, a die block, cooperating punches and dies carried by the blocks, means for feeding stock to a cut-off die and cutting it into blanks of appropriate lengths and transferring the cut blanks to a body die for upsetting, transfer slide operating means adjustable to assure proper timing of the machine, and a knock-out pin operating in the body die with appropriate means for operating such pin.

The heading machine above briefly described is well known in the art and need not be here described in greater detail. In the succeeding description of my invention only those parts of the machine which have particular relation to my invention will be illustrated and described in detail, it being understood that the machine, in general, is of known construction and operation.

The machine illustrated in Figure 1 comprises a suitable frame structure 25 which supports the die and hammer blocks and associated operating mechanisms. The wire or stock is delivered, by means of a pair of grooved feed rolls 26 to a cut-off die 27, of known type, through a quill 28. The cut-off die is suitably mounted in die block 29 in a known manner, which need not be illustrated nor described in detail, it sufficing to state that this die is of known type and is mounted in a known manner. An adjustable wire stop 30, also of known type and mounted in a known manner, is alined with the cut-off die 27 and determines the length of wire or stock which projects beyond the inner face of this die, it being understood that the means for operating the feed rolls 26

is adjustable, in a known manner, for varying the extent of turning thereof thereby varying the extent to which the wire or stock is advanced through the cut-off die 27 at each operation of the feed rolls.

The length of wire projecting beyond the inner face of cut-off die 27 is severed from the remainder of the wire, by a cut-off knife 31 carried by a cut-off bar 32, which is reciprocated transversely of die block 29 in a known manner and in proper timed relation to the operation of the feed means and the ram. A fiddle bow carrier 33, of known type, is provided, this carrier having a finger 34 which cooperates with knife 31 for transferring the cut-off length of wire or blank 35 into alinement with the bore of a body die 36 mounted in die block 29 in a known manner. The travel of cut-off bar 32 toward the right, as viewed in Figure 2, is such that the blank 35 is positioned as shown in this figure when the hammer block, to be described presently, moves toward the die block, bar 32 and knife 31, as well as carrier finger 34, being withdrawn when blank 35 has entered body die 36 to a proper extent, and prior to movement of the upsetting or coning die into full cooperating relation to the body die.

Body die 36 is provided, in its inner end, with a polygonal recess 37 about the bore of this die. The recess 37 is square, in the particular form illustrated by way of example, but may be of any other suitable polygonal shape, such as hexagonal. A knock-out pin 38 is slidable through the bore of die 36 and is provided, adjacent its outer end, with a guiding collar 39 operable in a bore 40 in block 29. Block 29 is further provided with a bore of increased diameter extending from bore 40 to the outer face of block 29, which enlarged bore receives a bushing 41. A knock-out rod 42 is slidably mounted in bushing 41 and contacts, at its inner end, the outer end of knock-out pin 38. The outer end of rod 42 contacts the rounded end of a knock-out lever 43 pivoted adjacent its other end, at 44, for movement about a vertical axis. A pull rod 45 is appropriately connected to lever 43, at approximately the mid-portion thereof, and is operated in a known manner for swinging the lever in a counterclockwise direction about its pivot 44, as viewed in Figure 2, for forcing the knock-out rod 42 inward of head 29. Movement of lever 43 in a clockwise direction is limited by an adjustable back stop 46 disposed for contact with the rounded end 47 of the lever, this rounded end contacting the outer end of rod 42. Knock-out pin 38 and rod 42 determine, in conjunction with the back stop 46, the extent to which blank 35 projects beyond the inner face of body die 36 and, therefore, the portion of this blank which is to be utilized in forming the desired head thereon. The knock-out lever and the knock-out rod and pin also function to eject the blank from the body die 36 at the appropriate time, as will be hereinafter explained.

A trimming die 50 (Figure 3) is mounted in die block 29 in a known manner, below and adjacent body die 36, this trimming die having an opening 51 the lengthwise axis of which is in the vertical plane of the axis of body die 36. Opening 51 comprises an inner portion 52 which tapers slightly outward, and an outer portion 53 which flares outward. The opening 51 corresponds in cross-sectional shape to the shape of the head formed on the blank, being square in the particular form illustrated by way of ex-

ample, and the inner end of inner portion 52 of opening 51 is of a size to receive tightly the inner portion of the head of a blank, as and for the reason to be presently described. Die block 29 is provided with a vertical groove 54 of considerable depth in its outer or rearward face and extending from its lower edge, this groove opening at its upper end into a substantially horizontal passage 55 formed in block 29 and extending outward from the outer face of trimming die 50, the inner end of passage 55 extending about opening 51 through trimming die 50 in spaced relation thereto.

Die block 29 and the parts associated therewith cooperate with a hammer block 60 and a set of associated punches, comprising an upsetting or coning punch 61, a heading punch 62 and a trimming punch 63, these punches being mounted in the hammer block 60 in a known manner. The punches 61, 62, and 63 have their lengthwise axes disposed in a common vertical plane which coincides with the vertical plane of the axis of body die 36, and the axes of punches 61 and 63 are equi-distant from the axis of punch 62. Hammer block 60 is mounted, in a known manner, upon a transfer slide 64 carried by a ram 65 mounted for horizontal movement and reciprocated by means of an associated pitman 66. At its lower end slide 64 is provided with a flange 67 bolted to a plate 68 slidably mounted at its lateral edges in grooved blocks 69 pivoted by studs 70 in the ends of the arms of a U-shaped member or stirrup 71. This stirrup 71 is rockably mounted, by stub shafts 72, in frame 25. A crank arm 73 is secured to one of the stub shafts 72 and has attached thereto operating mechanism by means of which the transfer slide 64 is reciprocated in timed due relation to the operation of ram 65, in a known manner. Means is provided for limiting movement of the transfer slide 64 in either direction and, if desired, for locking it in adjustment, such means being well known in the art.

Referring to Figures 4 to 9, inclusive, the upsetting or coning punch 61 is of cylindrical shape and is provided, in its inner end, with a frusto-conical recess 61a for receiving and upsetting the end portion of the blank. The heading punch 62, also of cylindrical shape, is provided in its inner end with a polygonal recess 62a, shown as square, and with a supplementary slightly rounded recess 62b of the same configuration as recess 62a and serving to impart the desired round to the outer face of the blank head. Recess 62a is approximately equal in depth to one-half of the thickness of the desired bolt head, it being noted that recess 37 of body die 36 corresponds to recess 62a of heading punch 62 and is also equal in depth to approximately one-half of the thickness of the desired bolt head. The trimming punch 63, of cylindrical form for the major portion of its length, is provided at its inner end with a reduced projection or finger 63a of polygonal cross-section, square in the particular form illustrated, of a size to pass through portion 52 of opening 51 of the trimming die 50.

In producing headed bolt blanks in accordance with my invention, the wire or stock is fed to the cut-off die 27 and the blanks 35 are transferred from in front of the cut-off die into position in alinement with the body die 36, as in Figure 2. Immediately thereafter the hammer block 50 is moved toward die block 29, transfer slide 64 being lowered so that the coning punch 61 is alined with body die 36, as in Figure 12. In

the continued travel of hammer block 60 toward die block 29 blank 35 is moved inwardly of body die 36, forcing end 47 of knock-out lever 43 rearward into contact with stop 46, at which time a portion of blank 35 projects beyond the inner face of die 36. In the further travel of hammer block 60 this projecting portion of blank 35 is upset by the coning punch 61, thus producing the blank of Figure 13A, which may be designated blank 35a. In this blank shank portion 35a¹ retains its original diameter, end portion 35a² has been upset and is of frusto-conical shape, and a flange 35a³ of considerable thickness approximating one-half of the thickness of the desired head, is produced about shank 35a¹ at the base of the upset portion 35a². This blank 35a results from the step shown in Figures 12 and 13. Hammer block 60 is then moved away from die block 29 and the transfer slide 64 is moved upward so as to bring the heading punch 62 into coaxial alinement with the body die 36, as in Figure 14, the blank 35a remaining in the body die. Hammer block 60 is then moved into cooperating relation with the die block and heading punch 62 smashes down the frusto-conical upset portion 35a² of blank 35a and also expands the flange 35a³ of the blank, the recesses 37 and 62a and 62b of body die 36 and heading punch 62, respectively, cooperating to form a head of the desired polygonal shape, size and thickness upon the end of the blank, thus producing blank 35b of Figure 15A, which blank comprises the shank 35a¹ having at one end thereof a head 35b¹ of the desired thickness, this head, in the particular instance illustrated, being square. It will be noted that the head 35b¹ has a relatively thin fin 35b² extending thereabout substantially midway between the inner and the outer faces of the head. This step is illustrated in Figures 14 and 15.

When the hammer block 60 starts to move away from the die block 29, after the heading step of the operation illustrated in Figure 15, the knock-out lever 43 is operated so as to force the knock-out rod 42 inward, thus causing inward movement of knock-out pin 38 simultaneously with and at the same rate as the movement of hammer block 60 away from die block 29, the parts of the mechanism being appropriately timed for that purpose. The travel of lever 43 is such that the inner end of knock-out pin 38, in its innermost position, is flush with the inner face of body die 36. This movement of the knock-out pin, in conjunction with the formation of approximately one-half of the head 35b¹ of the blank 35b in the heading punch 62, fitting tightly into the recess of this punch, serves to retain the blank 35b in heading punch 62 for movement therewith. This will be clear from Figure 20, illustrating the operation just described. When hammer block 60 has been moved a proper distance away from the die block 29, immediately following the heading step of the operation described, transfer slide 64 is lowered so as to aline coning punch 61 with body die 36, as in Figure 12, a second blank 35 is disposed between and in alinement with the body die 36 and the coning die 61, and hammer block 60 is then moved toward the die block 29, it being noted that the headed blank 35b carried by heading punch 62 is then disposed in coaxial alinement with the opening 51 of trimming die 50. In the continued closing movement of hammer block 60 blank 35 is inserted into body die 36, the projecting end portion of this blank is

upset and partially formed and, at the same time, the inner portion of head 35b¹ of blank 35b is inserted into portion 52 of opening 51 of the trimming die 50, in which it has a tight fit, as will be clear from Figure 17. In the reverse movement of hammer block 60 the outer portion of head 35b¹ of blank 35b is pulled out of the recess of heading punch 62, the blank then remaining in the trimming die with the inner portion of the head fitting tightly therein and fin 35b² of flash metal seating against the inner face of the trimming die, as shown in Figure 18. The transfer slide 64 is then moved upward so as to align the heading die 62 with the blank 35a in the body die, this also serving to align the finger 63a of trimming punch 63 with the head of the blank 35b retained in the trimming die, as will be clear from Figure 18. Hammer block 60 is then moved toward the die block 29 thus forming the head 35b¹ upon the blank 35b, in the manner previously described, and at the same time the blank 35b previously inserted into the trimming die is forced through the latter, by the trimming punch, thus trimming the fin 35b² of flash metal from head 35b¹, producing the blank 35c of Figure 19A, having a square head 35c² at the end of the shank, from which head the flash metal has been trimmed, the blank thus produced being in finished form so far as concerns the heading and trimming thereof.

Obviously, instead of providing the blank with a square head, any other suitable form of head may be provided. In Figures 21 and 22 I have shown a blank 35d having a hexagonal head 35d¹ with a relatively thin fin of flash metal 35d² extending about the head. In Figures 23 and 24 the flash metal has been trimmed from the head, producing the blank 35e having a finished hexagonal head 35e¹.

It will be noted that in the lower position of the transfer slide 64 a blank 35 will be upset by the coning punch 61 and, during this upsetting step of the operation, a headed blank 35b will be inserted into the trimming die by the heading punch 62, whereas, in the upper position of the transfer slide 64 an upset blank 35a will be headed by the heading punch 62 while a headed blank is being driven through the trimming die by the trimming punch 63. In this manner, I am able to produce a completely headed and trimmed blank at every other stroke of the hammer block 60 toward the die block 29. As a result, I am enabled, by the machine of my invention, to produce headed bolt blanks and similar articles at relatively high speed in a single machine, this machine serving to trim as well as to head the blanks, thus eliminating all necessity for an additional trimming machine. I effect a further material saving in the cost of production by providing heading and trimming means capable of high speed operation on a production basis with resulting lowering in cost of production per unit.

In the trimming step the trimming punch 63 may be only of such length as to force the headed blank through the trimming die a sufficient distance to effect the trimming operation. The trimmed blank then rests upon the lower wall of the passage 55, as will be clear from Figures 19 and 20. As succeeding blanks are forced through the trimming die the previously trimmed blanks are pushed along the passage 55 until they enter the groove 54, and are then discharged downward through this groove, as will be clear

from Figure 3. The trimmed blanks thus discharged from the die block 29 may be collected in a suitable receptacle properly positioned beneath the die block and the flash metal trimmed from the heads of the blanks, which drops downward at the inner face of die block 29, may also be collected in a suitably disposed receptacle, as will be obvious, it not being necessary to show such receptacles.

It will be understood by those skilled in the art that changes in the machine of my invention may be resorted to without departing from the field and scope of the same, and I intend to include, in this application, all such variations as fall within the scope of the appended claims.

I claim:

1. In a heading and trimming machine for producing headed bolt blanks, a die block, a body die and a trimming die carried by said block, a hammer block, a coning punch and a heading punch and a trimming punch carried by said hammer block, and means effective for causing relative movement of said blocks one toward and away from the other and for alternately aligning said coning punch and said heading punch and said heading punch and said trimming punch with said body die and said trimming die, respectively, in timed relation to the relative movement of said blocks one toward and away from the other.

2. In a heading and trimming machine for producing headed bolt blanks, a die block, a body die and a trimming die carried by said block, a hammer block, a coning punch and a heading punch and a trimming punch carried by said hammer block, means for moving said hammer block toward and away from said die block, and means for moving said hammer block into two positions, a first position with said coning punch and said heading punch respectively aligned with said body die and said trimming die during a stroke of said hammer block toward said die block, and a second position with said heading punch and said trimming punch respectively aligned with said body die and said trimming die during the next succeeding stroke of said hammer block toward said die block.

3. In a heading and trimming machine for producing headed bolt blanks, a die block, a body die and a trimming die carried by said block, a hammer block, a coning punch and a heading punch and a trimming punch carried by said hammer block, means for moving said hammer block toward and away from said die block, means for moving said hammer block into a first position at the end of a stroke thereof away from said die block and a second position at the end of the next succeeding stroke of said die block away from said hammer block, said coning punch and said heading punch being respectively aligned with said body die and said trimming die, in said first position of said hammer block, said heading punch and said trimming punch being respectively aligned with said body die and said trimming die, in said second position of said hammer block, a knockout pin operating through said body die, and means for operating said pin comprising backstop means and means for forcing said pin inward through said body die simultaneously with and at the same rate as the movement of said hammer block away from said die block, in said second position of said hammer block.

4. In a heading machine for producing headed bolt blanks, a die block, a body die and a trim-

ming die carried by said block, said body die having a bore therethrough for reception of a blank in the form of a length of stock and being provided in its inner face with a recess about said bore of appreciable depth less than the thickness of the desired bolt head for forming the inner portion thereof, a hammer block cooperating with said die block, said blocks having relative movement one toward and away from the other, three punches carried by said hammer block, one a coning punch cooperating with said body die and provided in its inner end with a conical recess effective for upsetting the end portion of the blank, the second a heading punch cooperating with said body die and provided in its inner end with a recess effective for forming the outer portion of the bolt head, the third a trimming punch effective for forcing the headed blank through said trimming die, and means for shifting one of said blocks relative to the other effective for aligning said punches with the dies cooperating therewith in proper sequence.

5. In a heading machine for producing headed bolt blanks, a die block, a body die and a trimming die carried by said block, said body die having a bore therethrough for reception of a blank in the form of a length of stock and being provided in its inner face with a recess about said bore of appreciable depth less than the thickness of the desired bolt head for forming the inner portion thereof, a hammer block cooperating with and movable toward and from said die block, three punches carried by said hammer block, one a coning punch cooperating with said body die, the second a heading punch cooperating with said body die and provided in its inner end with a recess effective for forming the outer portion of the bolt head, the third a trimming punch effective for forcing the headed blank through said trimming die, and means for shifting said hammer block effective for aligning said punches with the dies cooperating therewith in proper sequence.

6. In a heading machine for producing headed bolt blanks, a die block, a body die carried by said block having a bore therethrough for reception of a blank in the form of a length of stock and provided in its inner face with a recess about said bore of appreciable depth less than the thickness of the desired bolt head for forming the inner portion thereof, a trimming die carried by said block having an inwardly tapering opening adapted for reception of said inner portion of the bolt head with the latter fitting tightly in said opening, a hammer block movable toward

and from said die block, a coning punch carried by said hammer block cooperating with said body die for upsetting the end of said blank and partially forming said inner portion of the head thereon, a heading punch carried by said hammer block provided with a recess and cooperating with the body die for forming the head upon said blank, said heading punch also cooperating with said trimming die for placing the headed blank in the latter, and means for shifting said hammer block into a first position with said coning punch and said heading punch respectively aligned with said body die and said trimming die and a second position with said heading punch and said trimming punch respectively aligned with said body die and said trimming die, in proper sequence.

7. In a heading machine for producing headed bolt blanks, a die block, a body die carried by said block having a bore therethrough for reception of a blank in the form of a length of stock and provided in its inner face with a recess about said bore of appreciable depth less than the thickness of the desired bolt head for forming the inner portion thereof, a trimming die carried by said block having an inwardly tapering opening adapted for reception of said inner portion of the bolt head with the latter fitting tightly in said opening, a hammer block movable toward and from said die block, a coning punch carried by said hammer block cooperating with said body die for upsetting the end of said blank and partially forming said inner portion of the head thereon, a heading punch carried by said hammer block provided with a recess and cooperating with the body die for forming the head upon said blank, said heading punch also cooperating with said trimming die for placing the headed blank in the latter, a knock out pin operating in the bore of said body die, means effective for holding said pin against outward movement during the upsetting and heading operations and for forcing said pin inward and thereby ejecting the blank from said body die in the movement of said hammer block away from said die block after completion of the heading operation, and means for shifting said hammer block into a first position with said coning punch and said heading punch respectively aligned with said body die and said trimming die and a second position with said heading punch and said trimming punch respectively aligned with said body die and said trimming die, in proper sequence.

ARTHUR J. ALBERTS.