

Feb. 6, 1934.

A. A. KRAMER

1,945,531

ROLLING LADDER FOR TANKS

Filed Aug. 22, 1930

3 Sheets-Sheet 1

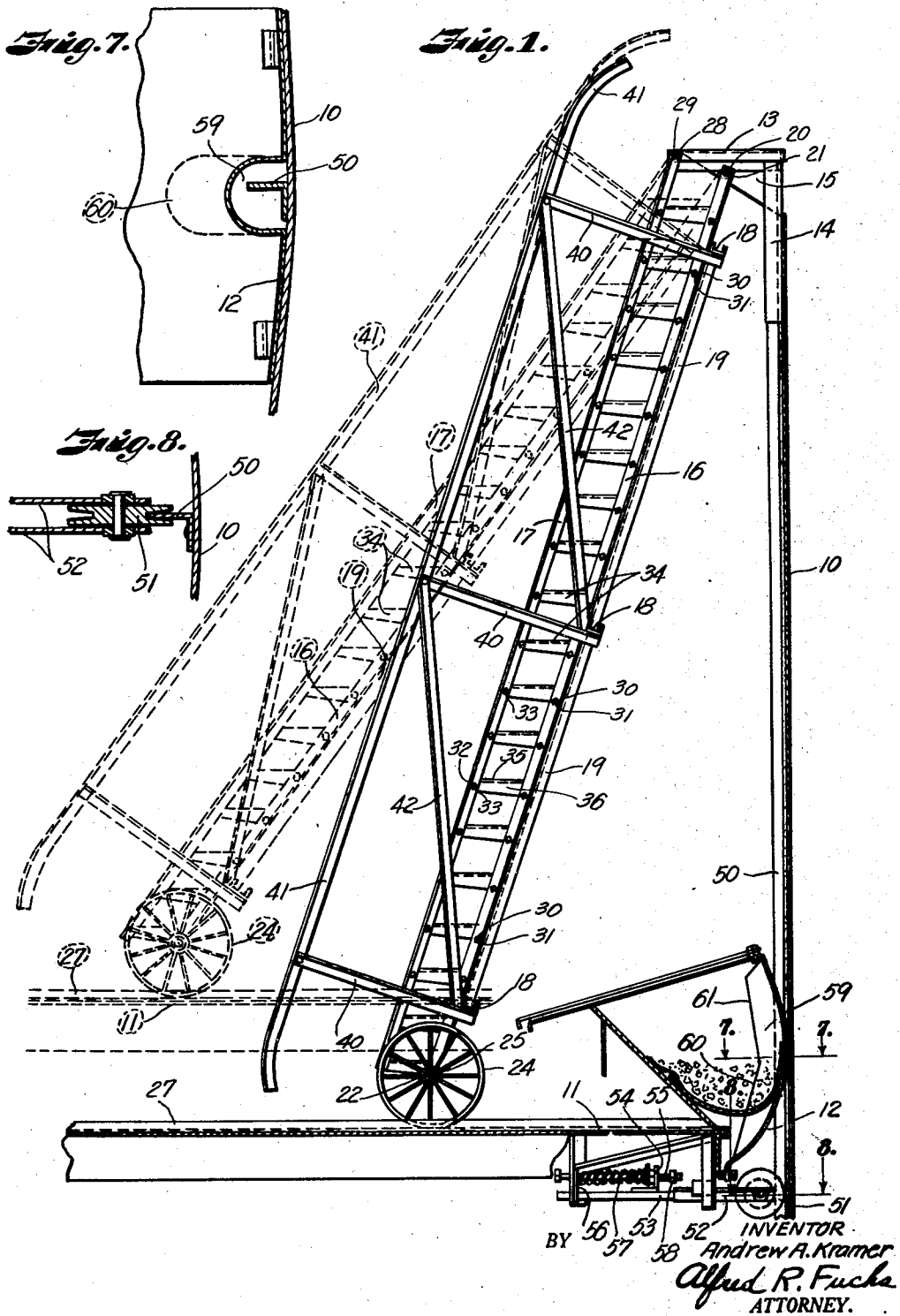

Feb. 6, 1934.

A. A. KRAMER

1,945,531

ROLLING LADDER FOR TANKS

Filed Aug. 22, 1930

3 Sheets-Sheet 2

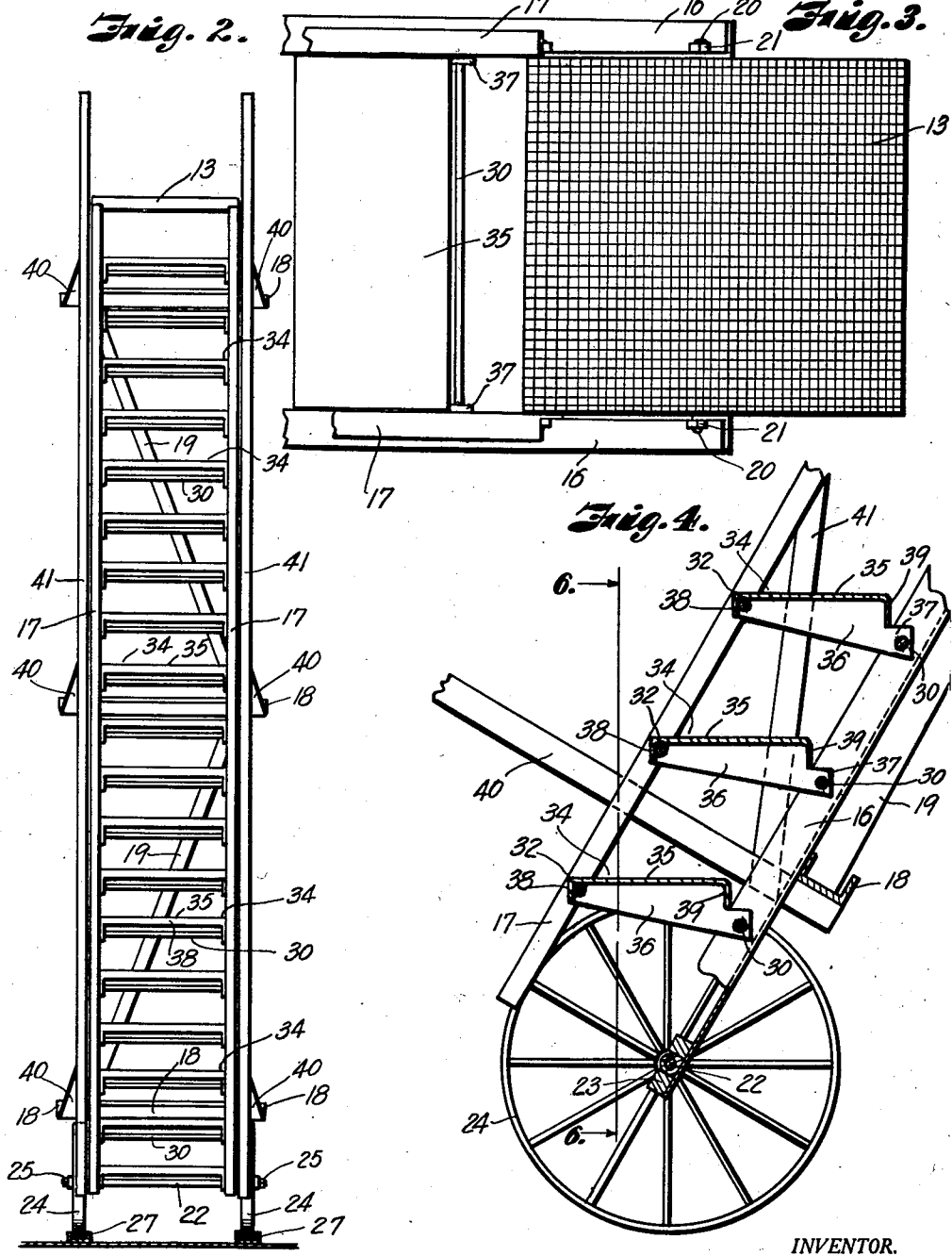

INVENTOR.

Andrew A. Kramer

BY

Alfred R. Fuchs

ATTORNEY.

Feb. 6, 1934.

A. A. KRAMER

1,945,531

ROLLING LADDER FOR TANKS

Filed Aug. 22, 1930

3 Sheets-Sheet 3

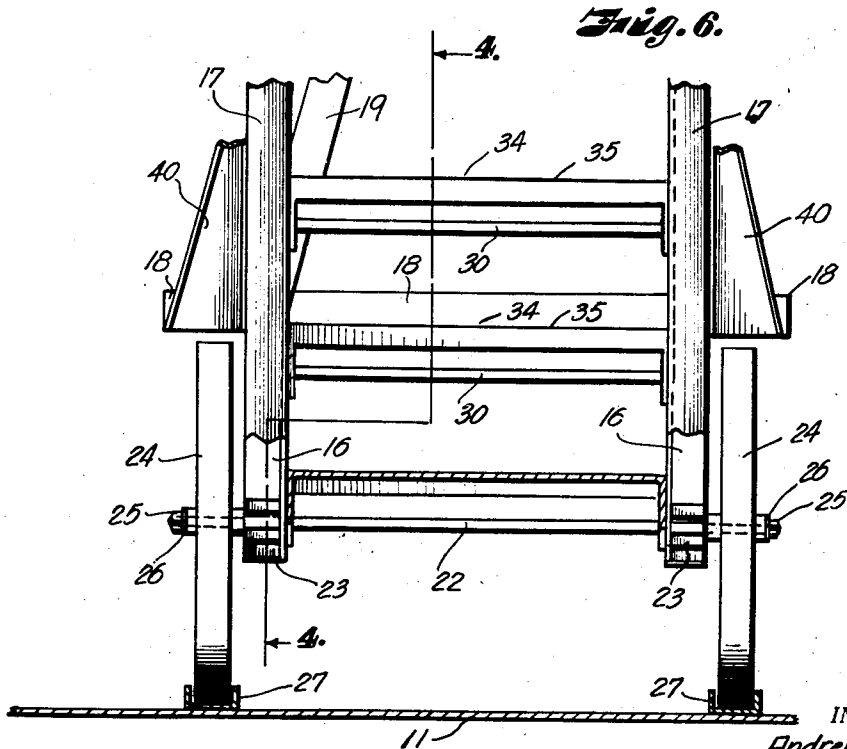
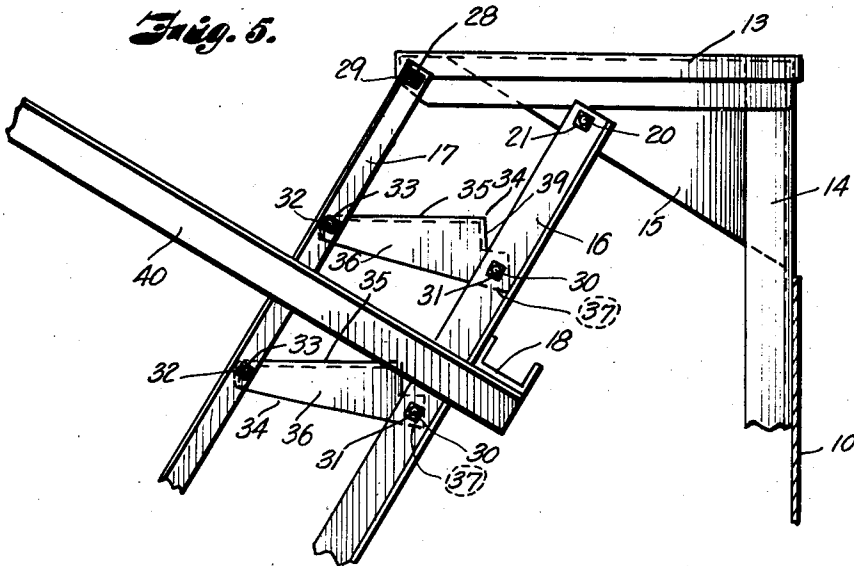

INVENTOR.

Andrew A. Kramer

BY

Alfred R. Fuchs

ATTORNEY.

UNITED STATES PATENT OFFICE

1,945,531

ROLLING LADDER FOR TANKS

Andrew A. Kramer, Kansas City, Mo., assignor
to George D. Beardsley, Kansas City, Mo.

Application August 22, 1930. Serial No. 477,059

4 Claims. (Cl. 228—54)

My invention relates to floating decks for tanks, and more particularly to a rolling adjustable ladder for use in conjunction with floating decks for tanks.

5 It is a purpose of my invention to provide a ladder that is mounted on the tank and engages with the floating deck in all the positions thereof to provide means for reaching said floating deck from the top edge of the tank, said ladder being
10 mounted entirely above the upper surface of the deck and having no part thereof projecting through the same.

It is a further purpose of my invention to provide a ladder of the above mentioned character that is mounted pivotally on the tank or on some member secured in fixed position on the tank adjacent the upper edge thereof and which has rolling engagement with means on the deck, said means preferably comprising a track engaged by
20 wheels on the ladder.

It is a further purpose of my invention to provide a ladder of the above mentioned character that has tread members that are provided with tread surfaces of considerable area so that the same are similar to the steps of a stairway, the tread surface being maintained, due to the construction of the ladder, in a substantially horizontal position, or substantially parallel to the floating deck and a platform leading to the ladder from the tank, for all angular positions that the ladder assumes relative to the platform on the tank. Thus the tread surfaces of the ladder or stairway are always in such a position that the same can be readily ascended or descended.

35 The ladder further preferably comprises a hand rail, which is mounted in such a manner that the same does not interfere in any way with the movement of the tread members to maintain the same in the proper position so that the upper surfaces thereof are horizontal. This is accomplished by providing a ladder construction in which a rigid frame is pivotally mounted on means provided on the tank, such as a platform, the hand rail being rigidly supported from said
40 frame, said frame having portions thereof that form parts of the side members of the ladder each side member comprising a pair of parallel longitudinal members, one of which is a member of said frame and the other of which is a bar that is pivotally carried by said means on the
50 tank and pivotally connected with the tread members, the tread members being pivotally connected with both the frame and said bars, and the arrangement of the pivots being such relative to
55 each other and to the pivotal connection of the

frame and bars with the tank that the tread members will always be maintained in a substantially horizontal position no matter what the angular position of the ladder may be. The relative position of the hand rail and the tread members change as the ladder assumes this position, but this is immaterial. The frame is always supported at both ends, being supported by the wheels engaging the runway or track on the deck at one end thereof and by means of the pivotal connection with the platform or other mounting therefor on the tank.

Other objects and advantages of my invention will appear as the description of the drawings proceeds. I desire to have it understood, however, that I do not intend to limit myself to the particular details of structure shown or described except as defined in the claims.

In the drawings:

Fig. 1 is a view showing a portion of the tank in section and a portion of the deck in section, the ladder being shown in side elevation in full lines in one position and the deck and ladder being shown in dotted lines in another position thereof.

Fig. 2 is an elevational view looking at the ladder from the front side thereof, a fragment of the deck being shown in section.

Fig. 3 is a fragmentary top plan view of the platform and the upper end portion of the ladder, the hand rail being omitted.

Fig. 4 is a view partly in section and partly in elevation of the lower end portion of the ladder, the section being taken substantially on the line 4—4 of Fig. 6.

Fig. 5 is a fragmentary side elevation of the upper end portion of the ladder and the platform.

Fig. 6 is a view partly in elevation and partly in section taken substantially on the line 6—6 of Fig. 4.

Fig. 7 is a section taken substantially on the line 7—7 of Fig. 1 on an enlarged scale, and

Fig. 8 is a section taken substantially on the line 8—8 of Fig. 1 on an enlarged scale.

Referring in detail to the drawings, in Fig. 1 is shown a portion of a tank 10, which has the floating deck 11, provided with a sealing means 12 engaging the side wall of the tank 10, mounted therein. The floating deck assumes different positions vertically of the tank as the level of the liquid therein varies, rising and falling with the level of the liquid. In order to provide suitable means for reaching the top of the floating deck from the top of the tank, my improved ladder 110

construction is provided. The ladder is preferably mounted pivotally relative to the side wall of the tank and mounted for rolling engagement with the top of the deck. While various means for mounting the ladder may be provided, it has been found particularly desirable to mount the ladder on a platform 13, which is mounted on suitable brackets 14 carried by the side wall of the tank 10 and provided with suitable bracing means 15. The ladder comprises side members each made up of a pair of longitudinal members 16 and 17, the same being preferably angles, as shown in the drawings. The members 16 are connected together by means of the cross members 18, which are shown as being channels, and which are welded or in any other suitable manner secured to the two members 16. Obliquely extending bracing members 19 are also provided which extend between the members 16 from one cross member 18 to the next cross member 18. The upper ends of the members 16 are pivotally mounted on the platform 13 by means of the bolts 20 having the nuts 21 thereon. The bolts 20 extend through the bracing members 15 in the arrangement shown, although obviously the same can extend through any part of the platform as long as the pivots are located on the desired axis.

At the lower end of the frame formed by the members 16, 18 and 19, a pivot rod 22 extends between the same and through suitable supporting blocks 23 welded or otherwise secured on the members 16, as shown in Fig. 6, the rod 22 extending laterally outward beyond the members 16 to provide axles for the wheels 24, the ends of the rods being threaded and being provided with nuts 25 and washers 26 for holding the wheels in position. The wheels 24 roll upon any suitable track or tread surface on the deck 11, the same being preferably engaged with a rail so as to guide the movements of the ladder at the lower end thereof. In the form shown in the drawings, the rail members are shown as being channels 27 on which the wheels 24 operate.

The members 17 are pivoted at their upper ends on bolts 28 provided with the nuts 29. The bolts 28 on the members 17 align and the pivotal axis thereof is located at a point forward and above that of the axis of the pivot bolts 20, as will be obvious from Figs. 1 and 5. The members 16 are provided with a series of openings that are in transverse alignment and are spaced a predetermined distance from the openings through which the bolts 20 pass. Pivot rods 30 extend through these openings and are provided with nuts 31 for holding the same in assembled relation with the members 16. The members 16 are arranged with the transverse flanges thereof extending away from each other so that the vertical flanges thereof lie on the inside or adjacent sides of the members 16. The longitudinal members 17 are provided with aligning openings that are spaced distances from the pivot openings for the pivot members 28 corresponding to the distances of the openings for the pivot rods 30 from the openings for the pivot bolts 20 in the members 16. Pivot rods 32 pass through these openings and are secured in assembled relation to the members 17 by the nuts 33, the angle members 17 being arranged with the transverse flanges thereof away from each other in a similar manner to the members 16.

The ladder is provided with tread members or steps 34 mounted on the pivot rods 32 and 30 and having the tread surfaces 35. The steps 34 serve as links connecting the members 16 and 17 so

that the same always move in parallelism and so that the steps 34 always are in position parallel to each other and the treads 35 thereof are substantially parallel to the top surface of the platform 13 and the deck 11 and thus substantially in a horizontal position. This is accomplished by having each of the openings for the pivot pins 32 in the members 17 spaced the same distance from the openings for the pivot pins 28 as are the openings for the pivot pins 30 in the members 16 from the openings for the pivot members 20 in said members 16, and by providing the pivot openings in the steps 34 for the rods 32 and 30 so that the same are the same distance apart as are the openings for the pivot members 28 and 20 on the platform 13, and so that the difference in the distance that the rod 30 and the rod 32 are from the tread surface 35 of each step 34 is the same as the difference in the distance that the pivot pins 20 and the pivot pins 28 are from the top surface of the platform 13. The side members, the steps and the top of the platform 13 thus form parallelograms for all positions of the ladder and the positions of the top surfaces of the steps are parallel to each other for each different position of the ladder, and are thus always substantially horizontal.

The tread members 34 are provided with side members 36, through which the pivot members 30 and 32 pass, said side members comprising rearwardly extending ears 37 that receive the pivot members 30. Said tread members further comprise a top wall portion 35 forming the tread surface thereof and having a depending flange 38 at their forward ends, and a flange 39 at their rear ends that extend downwardly to the top of the ears 37.

The channel members 18 have secured thereto by welding or in some similar manner, the standards 40, which extend at right angles to said channels, and are preferably made of angle iron. Said standards 40 serve to support the hand rails 41, there preferably being one hand rail on each side of the device. Diagonally extending bracing members 42 may also be provided extending from one of the members 40 to the adjacent member 40. The diagonal braces 42 and the members 40 are so spaced transversely that the members 17 will pass between the same, the supports for the hand rail thus causing no interference with the operation of the ladder.

It will be evident from Fig. 1 that the ladder will assume various angular positions, depending upon the position of the floating deck 11 relative to the platform 13. It will also be evident that the top or tread surfaces of the steps or tread members 34 will be substantially horizontal for all positions of the ladder. The ladder will, of course, assume a position that is substantially horizontal when the floating deck 11 reaches the top of the tank, and will assume a position that is nearly vertical when the deck is at its lowermost position and any position between the two extremes that may be necessary for any of the other positions of the deck between its uppermost and lowermost position.

Means is also provided to keep the deck from turning relative to the tank. This is necessary to keep the drain pipe, usually provided on a floating deck of this character, from being broken, and while such means can be provided as part of the ladder structure, it is found to be desirable to provide means on the tank and deck for this purpose to take any strain off the ladder. In order to provide such means for preventing rota-

tion of the deck in the tank, a guide rail 50 is provided, which may be of any desired shape, but is shown as being in the shape of an angle. The number of guide rails and cooperating guiding means provided depends upon the size of the deck, but preferably a pair of oppositely located rails 50 is provided. Cooperating with each rail 50 is a grooved roller 51, which is journaled in a bracket 52 provided on the guide bar 53 which is slidably mounted on the deck below the sealing means, suitable guiding means being provided for providing a straight line movement for the guide bar 53. An angular bracket 54 is provided on the guide bar 53 and a rod 55 extends therethrough, said rod also extending through an opening in the depending member 56 on the deck through a square opening in which the square guide bar 53 slidably extends. A coil spring 57 is mounted between the bracket 54 and the member 56, being under compression and tending to move the roller 51 outwardly toward the side wall of the tank. The rod 55 is threaded and is provided with a nut 58 thereon for limiting the outward movement of the guide bar 53. The sealing members 12 adjacent the guide rails 50 are provided with cut out portions which have the channel shaped guide 59 mounted therein of such a size as to permit passage of the rail 50 therethrough. The channel 59 is provided with oppositely inclined wall portions 60 and 61, with which the rail 50 is adapted to engage to deflect the sealing member 12 inwardly so as to prevent binding of the rail 50 and the channel through which the same passes. The upper surface of the platform 13 may be suitably roughened, as shown in Fig. 3 if desired.

Having thus described my invention what I claim and desire to secure by United States Letters Patent is:—

1. The combination with a tank and a deck vertically movable in said tank, of a ladder having one end thereof mounted on said tank and having the other end thereof engaging said deck to move thereon, whereby said ladder adjusts its position in accordance with the position of said deck in said tank and cooperating means on said tank and deck to hold said deck against rotation in said tank, said ladder having tread

members thereon and means for holding said tread members in a substantially horizontal position in any position of said ladder.

2. The combination with a tank and a deck vertically movable in said tank, of a ladder having one end thereof pivotally mounted on said tank adjacent the top thereof and having rolling means at the other end thereof engaging said deck to mount the same to roll thereon, cooperating means on said tank and deck to hold said deck against rotation in said tank and a platform mounted on said tank at the upper end of said ladder, said ladder having tread members pivotally mounted thereon, the pivots of said tread members being arranged to maintain the tread surfaces thereof substantially parallel to the surface of said platform for any angular position of said ladder.

3. The combination with a tank and a deck vertically movable in said tank, of a platform mounted on said tank, a ladder leading from said platform to said deck and engaging said deck to move thereon, said ladder having side members each made up of a pair of members pivotally connected with said platform and tread members having depending side flanges pivotally connected with one of the side members of each pair near the front thereof and having rearwardly extending ears pivotally connected with the other side member of each pair, the pivots of said side members and the pivots of said tread members being relatively located to maintain each of said tread members in any position of said ladder parallel to the position of said tread member in any other position of said ladder.

4. The combination with a tank and a deck vertically movable in said tank, of a ladder connected with said tank and engaging said deck in any position thereof, said ladder having tread members, means for mounting said tread members to maintain each thereof in any angular position of said ladder parallel to the position of said tread member in any other position of said ladder, a track on said deck and wheels on the lower end of said ladder engaging said track.

ANDREW A. KRAMER.

50

125

55

130

60

135

65

140

70

145

75

150