

E. E. CLEMENT.  
RAILWAY TRACK CONSTRUCTION.  
APPLICATION FILED AUG. 3, 1905.

Fig. 1.

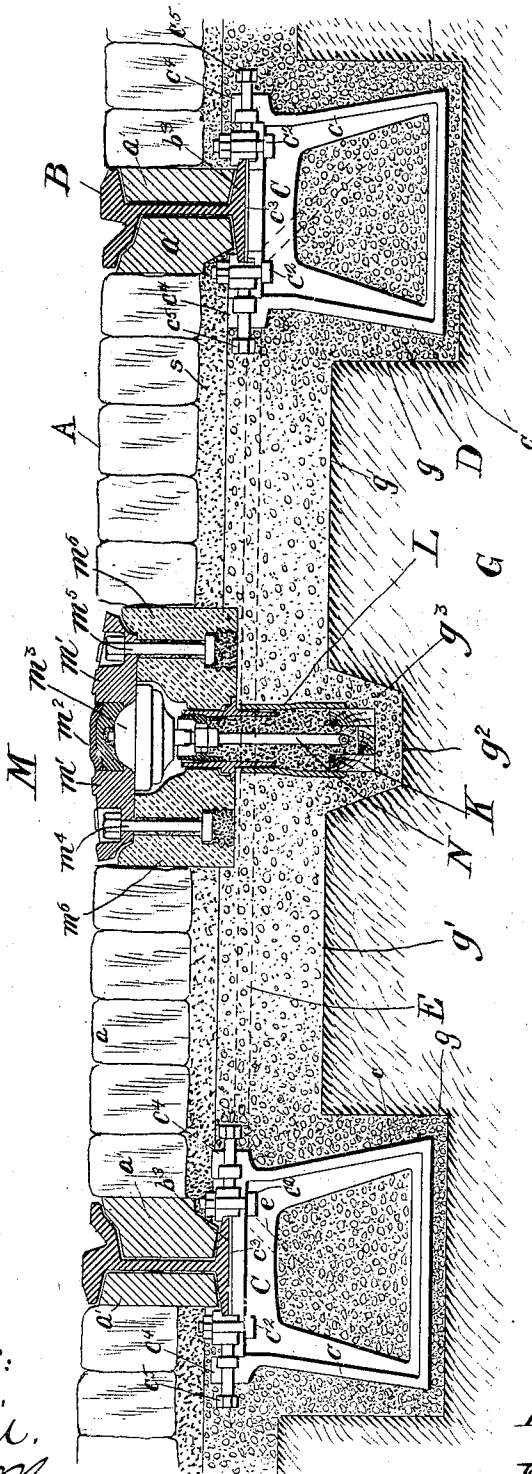

Witnesses:  
D. W. Edlin.  
James H. Mann.

Inventor  
Edward E. Clement.

E. E. CLEMENT.  
RAILWAY TRACK CONSTRUCTION.  
APPLICATION FILED AUG. 3, 1905.

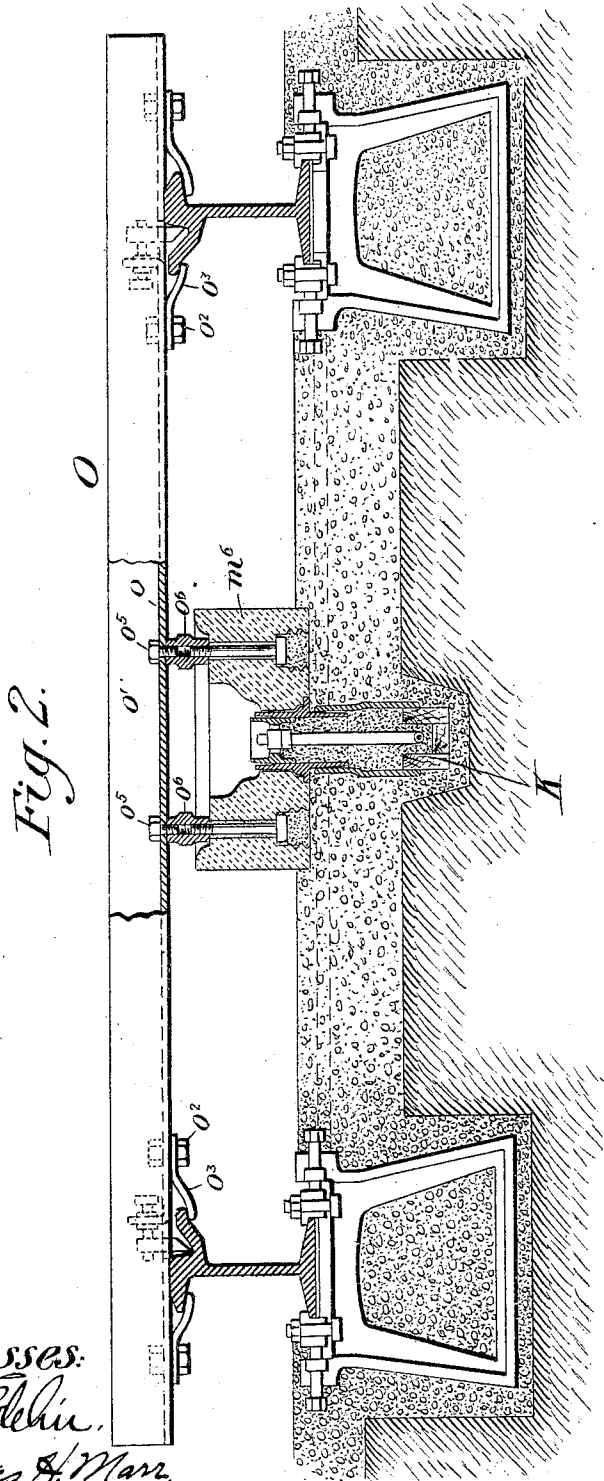

Witnesses:  
R. W. Edlin.  
James H. Marr.

Inventor:  
Edward E. Clement.

E. E. CLEMENT.  
RAILWAY TRACK CONSTRUCTION.  
APPLICATION FILED AUG. 3, 1905.

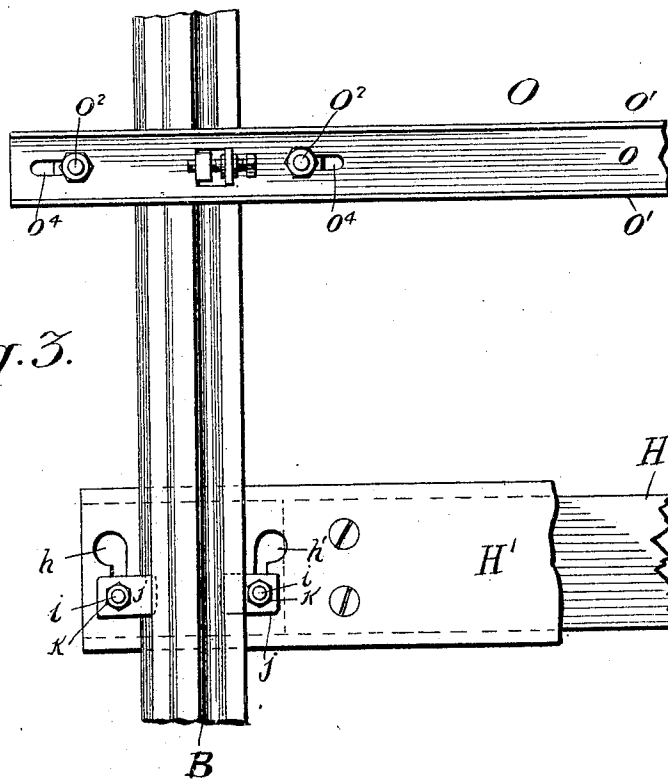

Fig. 3.

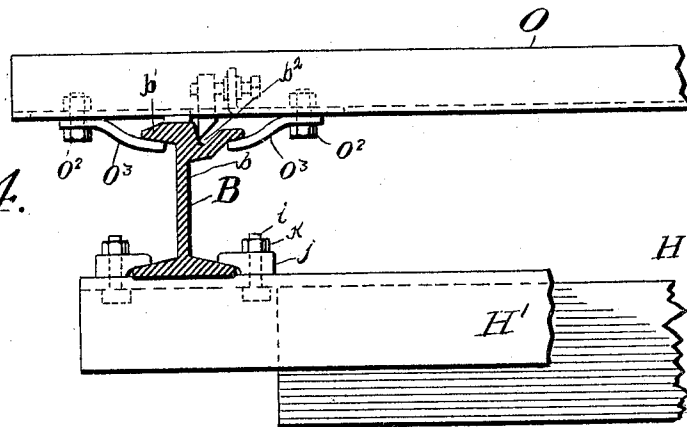

Fig. 4.

Witnesses:  
D. W. Edlin.  
James H. Mann.

Inventor:  
Edward E. Clement.

# UNITED STATES PATENT OFFICE.

EDWARD E. CLEMENT, OF WASHINGTON, DISTRICT OF COLUMBIA.

## RAILWAY-TRACK CONSTRUCTION.

No. 802,915.

Specification of Letters Patent.

Patented Oct. 24, 1905.

Application filed August 3, 1905. Serial No. 272,534.

*To all whom it may concern:*

Be it known that I, EDWARD E. CLEMENT, a citizen of the United States, residing at Washington, in the District of Columbia, have invented certain new and useful Improvements in Railway-Track Construction, of which the following is a specification, reference being had therein to the accompanying drawings.

This invention relates to means for and methods of railway-track construction and to the structure produced thereby.

More specifically stated, the invention relates to railway-track construction of that type wherein a concrete foundation is used, the rails being directly supported thereon. In such construction there is always more or less shrinkage of the concrete, and the matter of setting and supporting the rails and other parts coöperating therewith calls for special design in order to secure a permanent and accurate alinement and adjustment of all the parts.

It is one object of the present invention to secure this perfect alinement and adjustment of all the parts.

Another object of the invention is to produce a track system for electric railways having surface contacts for supplying current to the passing cars or trains, all contacts and other parts, as well as the rails themselves, being permanently and solidly supported upon and carried by a mass or masses of composition, to which they are anchored or in which they may be embedded in such manner that their relative positions and adjustment will be easily secured and permanently maintained.

According to this invention, broadly stated, a suitable trench or trenches being prepared, temporary supporting devices or ties are laid across the trench. Upon these the rails are supported and roughly alined. Yokes or anchors are hung upon the rails, and the contact devices are also hung upon or adjusted from the rails, there being thus a common reference of all the connected parts to the rails as the base for adjustment. Beneath the contact devices and intermediate of the rails a small trench is first excavated and the feeder-cable laid therein. After the parts are in position and adjusted to the extent required in the rough the trenches are filled with concrete or other composition, and after this is set the rails are finally permitted to come upon the concrete and the various temporary supporting devices or ties are removed.

The invention is illustrated in the accompanying drawings, in which—

Figure 1 is a transverse section of a track structure produced according to and embodying the present invention. Fig. 2 is a similar section prior to completion, showing the temporary supporting devices for the contact-blocks. Fig. 3 is a plan view, and Fig. 4 is a side view, showing a temporary supporting-tie and the contact-supporting means attached to a rail.

The supporting structure shown herein is preferably formed as a monolith or continuous unbroken mass of concrete or artificial stone. In some cases segregated masses of concrete may be employed supporting the rails and conduit at intervals after the manner of ties; but the principal embodiment of this invention is in a monolithic structure. This preferably comprises two longitudinal masses extending along the sides of the track, each beneath one line of rails, these being connected by a horizontal web of the same material, which serves the double purpose of connecting the side bodies and of making a solid foundation for the road-surface and the contact-bodies and supports beneath the rails. Suitable reinforcing-rods are embedded in this horizontal body and also, if desired, in the side bodies at intervals, the cross-rods having their ends extending down and embedded in the masses of the side bodies. In each side body metallic anchors or yokes are provided at intervals, also embedded in the masses, and upon this means are secured for holding down and adjusting the rails. The rails rest upon the concrete without bearing upon the yokes, although held down by the latter, and the central contact-bodies also rest upon the concrete, being surfaced thereby and not resting their weight upon their connections with the feeder-conduit, although held down thereby or by special yokes, if desired. In order to secure the various ends desired, use is made of certain temporary devices in laying the track and the contact-bodies, which will be fully set forth hereinafter.

Referring to the drawings, A is the road-surface, paved with blocks *a* or in any other suitable manner, this surface paving resting on a layer of sand *s*. The rails B rest upon the solid body of concrete D, which extends across the horizontal surface *g'* of the earth G and into the side trenches *g*, cut longitudinally beneath the rails. This mass of concrete extends along the track continuously and at

intervals has embedded in it the reinforcing-rods E, having their ends  $e$  bent down into the sidetrenches in order to gain a firm anchorage in the side bodies. At intervals in each side body a yoke C is embedded, consisting, preferably, of an open frame with flanged sides  $c$  and provided at its upper end with opposite lugs  $c^4$ , within which work the adjusting-screws  $c^5$ , these confining between them the holding-blocks and vertical screws or bolts  $c^2$ , the foot  $b^3$  of the rail B being embraced between these holding-blocks, and the rail being therefore adjustable to exact gage by manipulating the screws  $c^5$ .

In setting the rails and contacts the horizontal trench is first excavated and surfaced, as at  $g'$ , and the longitudinal trench for the feeder-conduit, as  $g^2$ . In the latter the conduit K is laid in a bed of concrete  $g^3$ . Temporary cross-ties are then supported transversely in the trench  $g'$ , the rails laid thereon, and roughly brought to gage. It is preferable for this purpose to use the form of cross-tie shown in Figs. 3 and 4, which consists of a wooden body portion H, surmounted by the channel member H', suitably secured thereto and of a length greater than that of the body portion H. The overhanging ends thus produced facilitate the attachment and detachment of the rails, while the body portion H is adapted to the operation of surfacing the rails by tamping up under a tie. At each end of the tie the overhanging channel portion is perforated by the slotted holes  $h h'$ , through the enlarged portion of which the head of the bolt  $i$  freely slips to be engaged by the slotted portion of the hole for the purpose of clamping the rail and tie by means of the clips  $j j'$  and nuts  $k k$ . Having secured the rails to the temporary ties, the side trenches  $g$  are dug and the yokes or anchors C hung upon the rails. In this part of the process shims or distance-pieces  $e^3$  are interposed between the rail-foot  $b^3$  and the head of each yoke. In finishing these are removed, as well as the temporary ties, leaving the rails, as shown, raised from the yokes and adjustably held down thereby upon the concrete.

In the drawings a type of rail in common use is shown at B, with a head  $b'$ , a high web  $b$ , and a groove  $b^3$ , having an inclined face. The concave sides of the rail-figure are filled out by means of the special blocks  $a'$ , which it will be observed do not take or transmit any strains and which clear the adjusting and holding screws or bolts. Any other form of rail or any new rail of the same form can be substituted for the rails shown without in any material degree disturbing or injuring the main body of the concrete bed. Moreover, the road-surface may be prepared as desired and the same replaced from time to time without injury to the concrete.

In order to provide for the contacts, temporary supports O are placed upon the rails

and secured thereto by means of clamps  $o^3$ , bolted to the supports at  $o^2$ . These supports, which also perform the function of standard gages, are preferably channel-irons, having webs  $o$  and side flanges  $o'$ , so that while they are light enough to be readily handled and transported they are very stiff and strong. As best shown in Figs. 3 and 4, each support is slotted at  $o^4$  for the bolts  $o^2$ , and the length is such as to span a pair of rails. Intermediate of its ends each channel-beam O is drilled for bolts  $o^5$ , by which the supporting body or matrix for the conduit-body is suspended during the construction. The conduit structure preferably employed in this system is shown complete in Fig. 1. The feeder-conduit K is laid in the intermediate trench  $g^2$ , filled with concrete or cement  $g^3$ . The surface contacts are distributed along this conduit at recurring intervals between the rails. Each contact device is indicated in its entirety by the letter M. Each comprises an insulating body or support  $m^6$ , which is conveniently made of artificial stone or cement and which is centrally chambered to receive the switch-cup  $m^3$  and perforated on each side to take the bolts  $m^5$ . Each bolt is preferably permanently screwed in the block from beneath with its head countersunk and embedded in cement. The shrinkage on these bolts is sufficient to keep them from turning, but special means for that purpose may be provided, if desired. Each conduit-chamber is connected with the feeder-conduit beneath by the branch L, which may be conveniently made of iron or other pipe, the upper end of which takes the drop-lip on a short flanged section of pipe, molded in the body  $m^6$ . Upon the body or block the metal cap-plate is screwed when the structure is complete by means of the bolts  $m^5$  and suitable nuts thereon. This cap-plate comprises two side bodies  $m^1$  of magnetic metal and an intermediate body  $m^2$  of non-magnetic metal, which, however, should be very hard and a good conductor. Within the cup  $m^3$  a movable magnetic circuit-closer is placed and connected by a flexible pigtail with the upper end of the tap N from the feeder. In the upper part of the cup  $m^3$  is a fixed conduit, connected to the body  $m^2$ . Upon the cars or the locomotive which operate upon this system magnets are provided in pairs extending along the bottom of the trucks between the wheels, and running along between the pairs of magnets are elongated contact-shoes, each preferably the length of a car. With this arrangement if a car passes over the structure shown in Fig. 1 the side bodies  $m^1$  become magnetized and lift up between them the loose contact inside the cup, so that it touches the upper fixed contact, thereby completing the supply branch from the feeder through the tap N to the contact-body  $m^2$  and thence to the contact-shoe on the car which is passing over it. It is to be un-

derstood that this method of operating cars is not claimed herein, the present invention being confined to the track structure and the method of its production.

5 In building the road after the temporary ties are in position and the rails supported thereon the condition is as represented in Fig. 2. The feeder-conduit K has been laid, the trench-ties are in position, and over each one  
10 the contact-block  $m^6$  is suspended from the rails or the support thereof. In the illustration Fig. 2 the support already described is employed, it being obviously necessary for smooth and economical service of the road  
15 that the contacts should be uniformly and permanently adjusted with regard to the surface of the rails. As already stated, after the temporary supports of Figs. 2, 3, and 4 are in position the block  $m^6$  becomes automatically  
20 centered and adjusted by means of the channel-beams O. In order that it may be surfaced correctly, a pair of distance-pieces  $o^6$  are provided, which by their length determine the exact spacing between the lower face  
25 of the channel-beam and the upper face of the block  $m^6$ . Each of these is oppositely threaded from its opposite ends and each is provided with a raised shouldered portion to take a wrench.

30 With the parts in the position shown the concrete is filled into the side trenches to embed the anchors or yokes of the rails, also into the intermediate trenches to embed the iron cross-rods and the branch pipes; but this  
35 cross-web of concrete is preferably not completed until after the temporary ties are removed. The cross-filling is then completed, as shown in Fig. 1, around the branch pipe and under the contact-blocks  $m^6$ . The filling  
40 about this block need not be tamped; but, if desired, some space may be left to be subsequently filled by grouting. The surfacing will be more accurate in this latter case, as the block will be permitted to settle when the  
45 shims are removed from beneath the rails.

In some cases the intermediate trench  $g^2$  can be omitted, the feeder-conduit being laid upon the surface of the cross-trench  $g'$ . The intermediate longitudinal trench is preferable because the temporary ties can be laid without  
50 any special provision for the conduit, being simply dropped across it.

It is to be distinctly understood that there are many changes possible to be made in this structure without departing from the spirit of the invention. Thus it is contemplated to support the block  $m^6$  and even the feeder connections and conduit, if desired, upon the temporary ties, the principal and governing  
60 requirement being that the parts shall be spaced and adjusted in common, so that when the structure is complete the contact-surfaces  $m^2$  and the various surface contacts M along the line will be definitely and uniformly placed  
65 with respect to the rails.

Having thus described my invention, what I claim, and desire to secure by Letters Patent of the United States, is—

1. In railway-track construction, a pair of rails, a monolithic body supporting both rails and formed with heavy portions directly beneath the rails and a lighter cross connecting web, together with contact devices embedded in said body between the rails, substantially as described. 70 75

2. In railway-track construction, a pair of rails, a monolithic body supporting the rails and composed of heavy side portions or stringers, with a lighter cross connecting portion or web, together with contact-carrying bodies embedded in and also carried by said monolithic body at intervals along the rails, substantially as described. 80

3. In railway-track construction, a pair of rails, a monolithic body extending beneath and continuously supporting said rails throughout their length, reinforcing means embedded in said monolithic body, and contact devices also embedded in said body and bearing the same relation to the rails throughout their length, substantially as described. 85 90

4. In railway-track construction, a pair of rails, and contact devices between the rails for supplying current to passing vehicles supported thereon, together with a monolithic body extending beneath and supporting both rails and contact devices, substantially as described. 95

5. In railway-track construction, a pair of rails, and contact devices between the rails for supplying current to passing vehicles supported thereon, together with a monolithic body having heavy side bodies or stringers extending beneath and supporting the rails, with a cross connecting-web connecting the stringers and supporting the contact devices, substantially as described. 100 105

6. In railway-track construction, a monolithic body having heavy side portions in the nature of stringers, together with an integral homogeneous cross connecting-web, reinforcing-rods embedded therein to strengthen the web, a series of anchors or yokes embedded in each stringer, rails supported upon the stringers and adjustably held by but not upon the yokes, and current-carrying devices supported and embedded in and upon said cross connecting-web in definite relation to the yokes and hence to the rails when adjusted, substantially as described. 110 115 120

7. In a railway-track structure, side yokes, a central conduit and contact devices for supplying current to cars, together with an integral homogeneous monolithic body carrying said yokes and other devices directly, and rails upon said yokes held down thereby upon the monolith, substantially as described. 125

8. In a railway-track structure, a pair of rails, a contact device, and a monolithic composition support common to both, with 130

means to hold the rails and contact devices in definite relation to each other upon said support throughout its length, substantially as described.

5 9. In a railway-track structure, rails and contact devices therefor, a homogeneous monolithic composition support common to both, and means to hold each directly upon

said composition support to be leveled and supported thereby, substantially as described. 10

In testimony whereof I affix my signature in presence of two witnesses.

EDWARD E. CLEMENT.

Witnesses:

ALEXANDER S. STEUART,

JAMES H. MARR.