



US 20070215388A1

(19) **United States**

(12) **Patent Application Publication**  
**Kirk et al.**

(10) **Pub. No.: US 2007/0215388 A1**

(43) **Pub. Date: Sep. 20, 2007**

(54) **DOWNHOLE APPARATUS FOR MOBILISING DRILL CUTTINGS**

(30) **Foreign Application Priority Data**

(76) Inventors: **Ian Alastair Kirk**, Milltimber (GB);  
**William Barron Bielside**, Aberdeen (GB);  
**Alistair Bertram Clark**, Westhill (GB)

Jun. 26, 2004 (GB)..... 0406782.3

Nov. 23, 2004 (GB)..... 0425663.2

**Publication Classification**

Correspondence Address:

**MIDDLETON & REUTLINGER**  
**2500 BROWN & WILLIAMSON TOWER**  
**LOUISVILLE, KY 40202**

(51) **Int. Cl.**  
**E21B 10/00** (2006.01)

(52) **U.S. Cl.** ..... **175/327**

(57) **ABSTRACT**

Apparatus for mobilising drill cuttings in a well, comprising at least one vane (12), and two or more blades (15). The two or more blades (15) define at least one fluid conduit between adjacent blades (15). The blades (15) and the or each vane (12) are rotatable relative to one another. The apparatus is provided to alleviate the problem of drill cuttings clumping together downhole. The or each vane (12) can be provided on a sleeve (5). The blades (15) can be mounted on a bushing (7) that is rotatably mounted on the sleeve (5).

(21) Appl. No.: **10/594,157**

(22) PCT Filed: **Mar. 24, 2005**

(86) PCT No.: **PCT/GB05/01199**

§ 371(c)(1),  
(2), (4) Date: **Sep. 26, 2006**

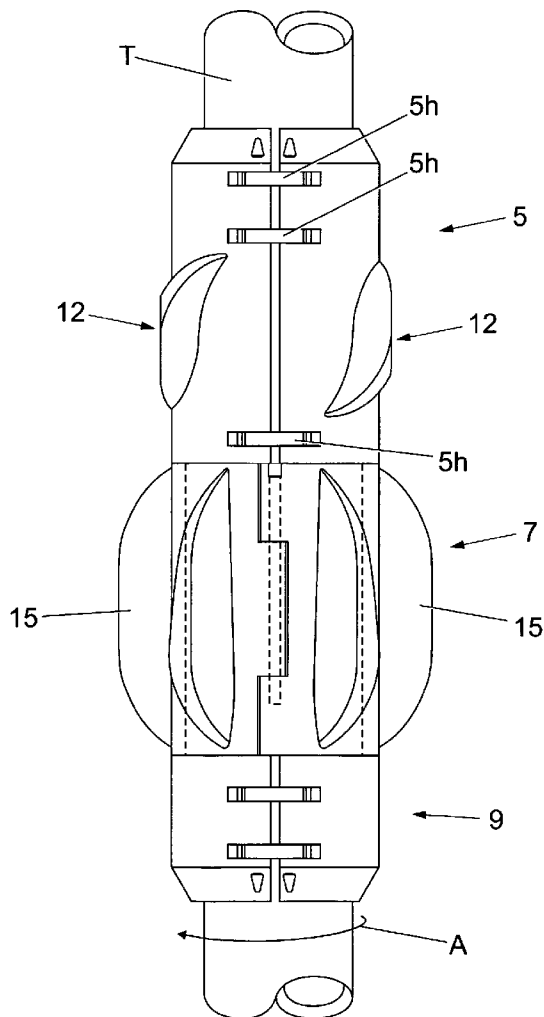

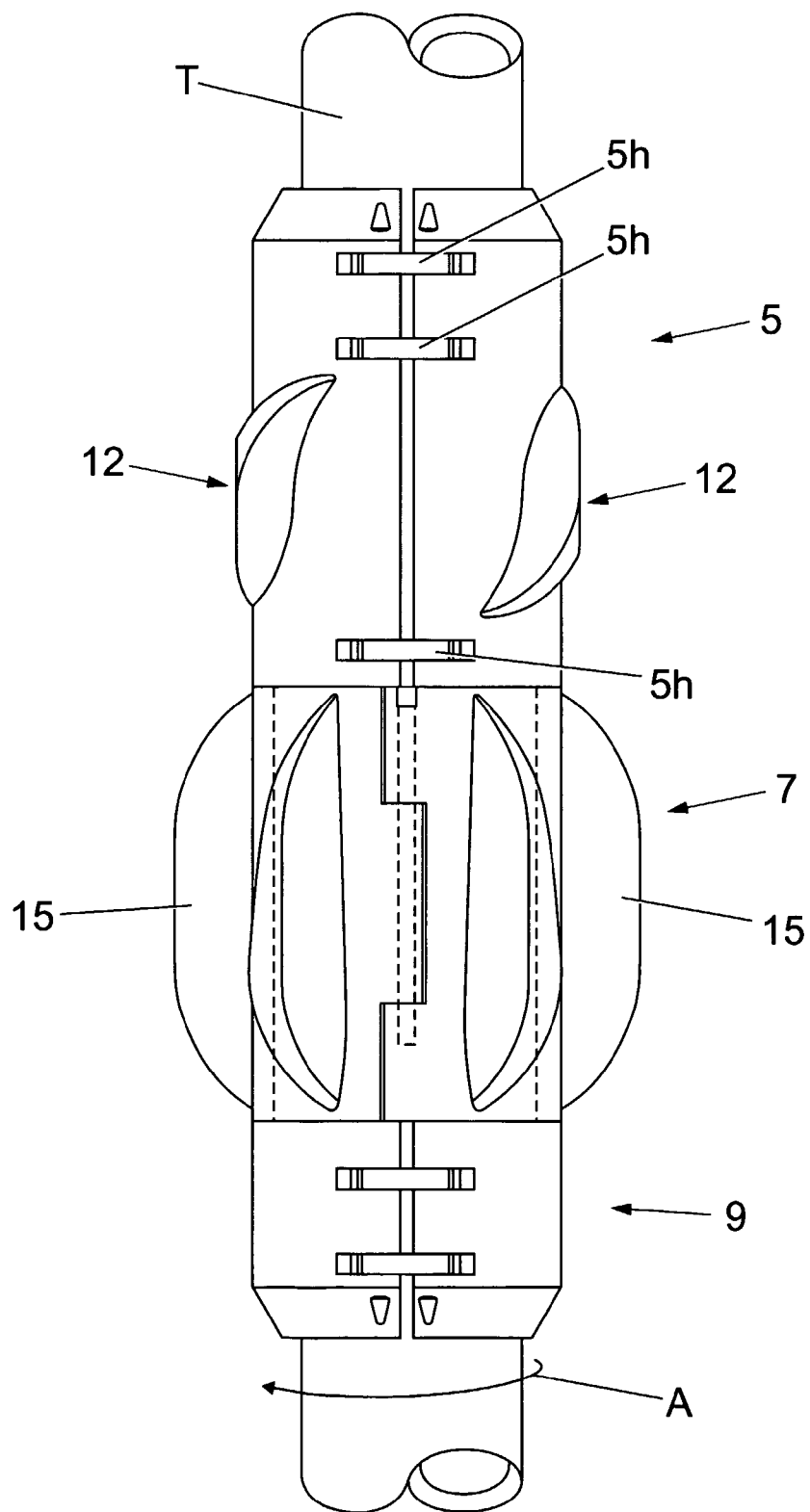
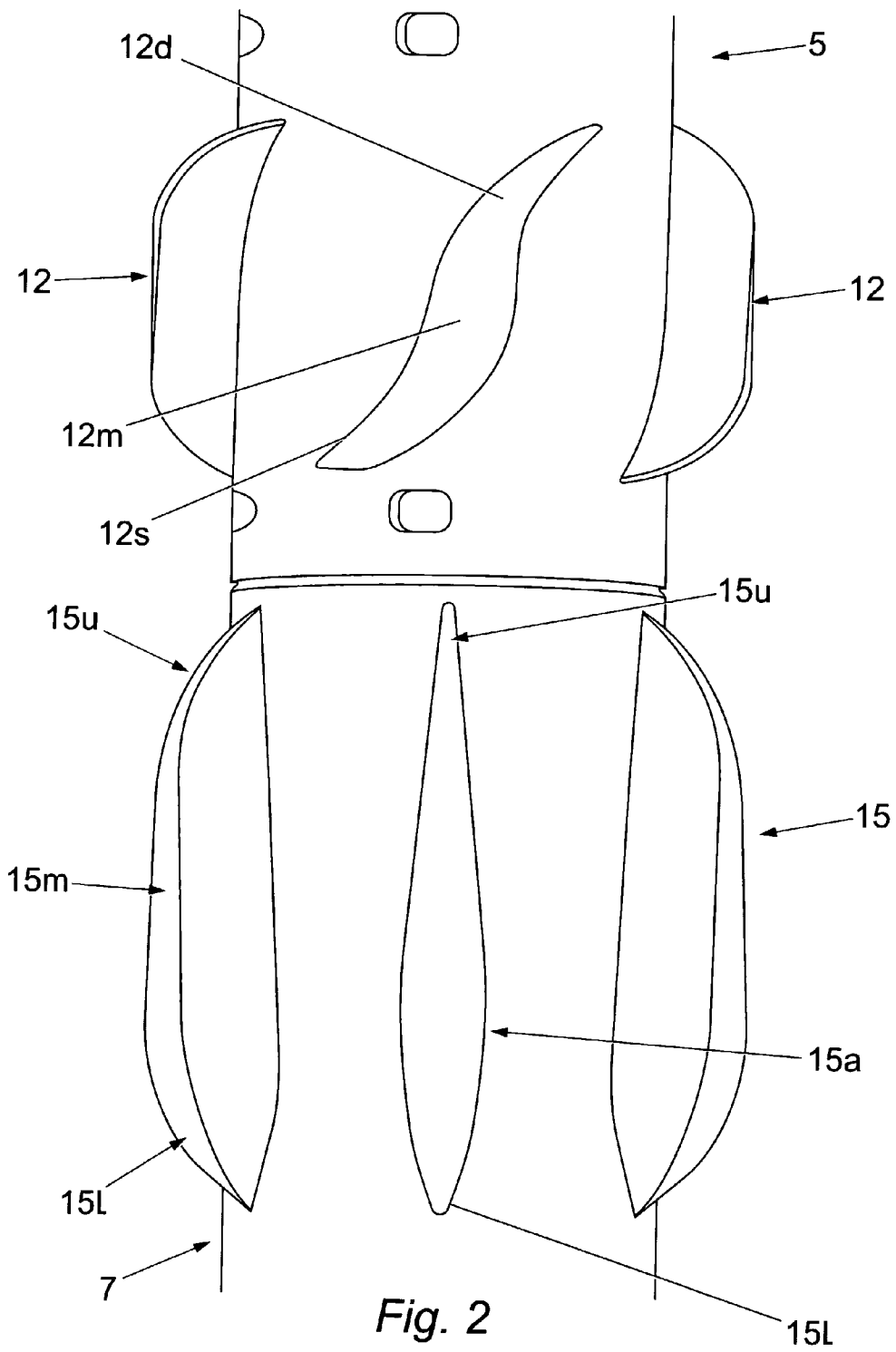

Fig. 1



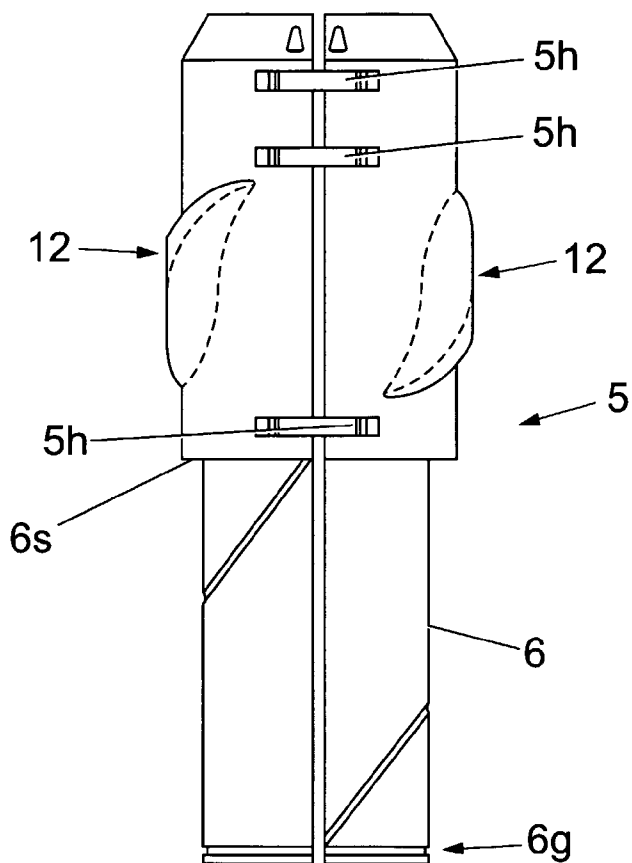

Fig. 3

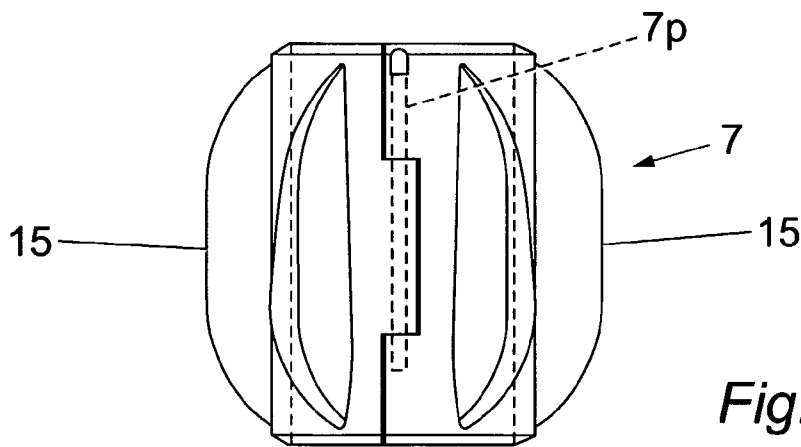

Fig. 4

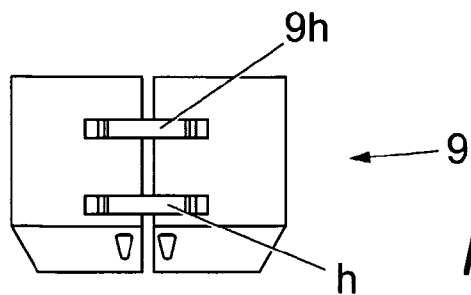
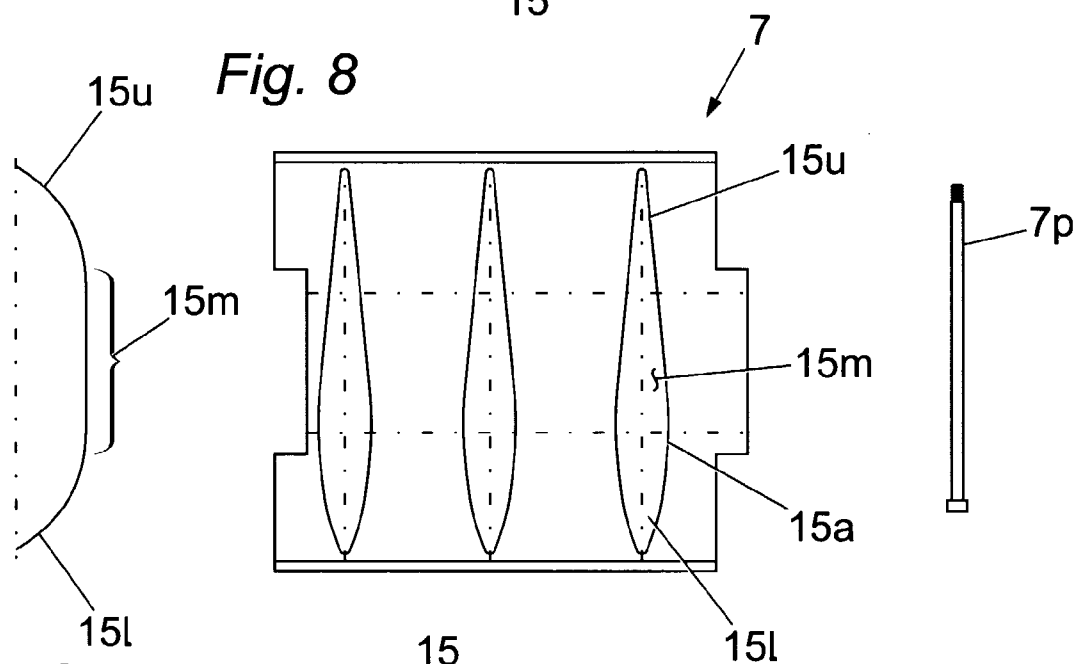
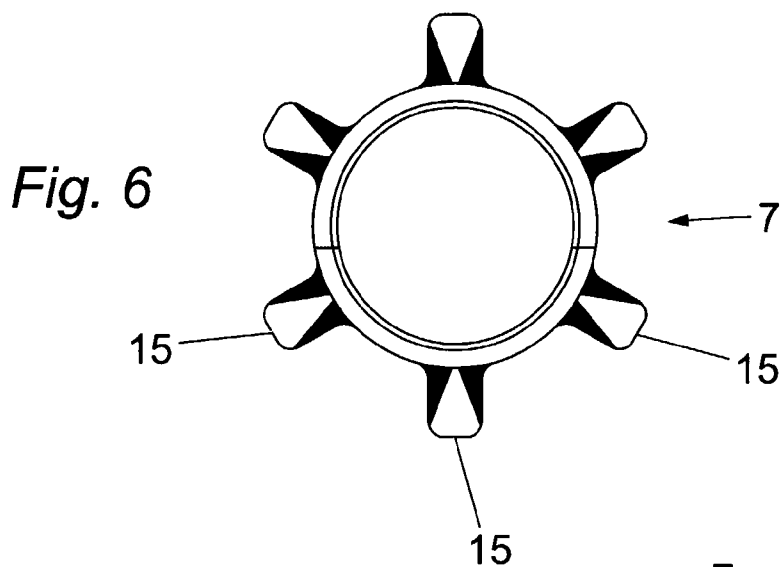
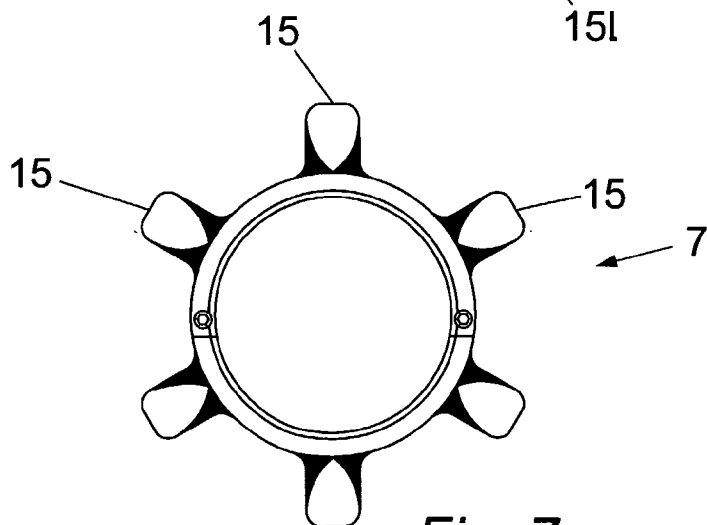

Fig. 5



*Fig. 9*



*Fig. 7*

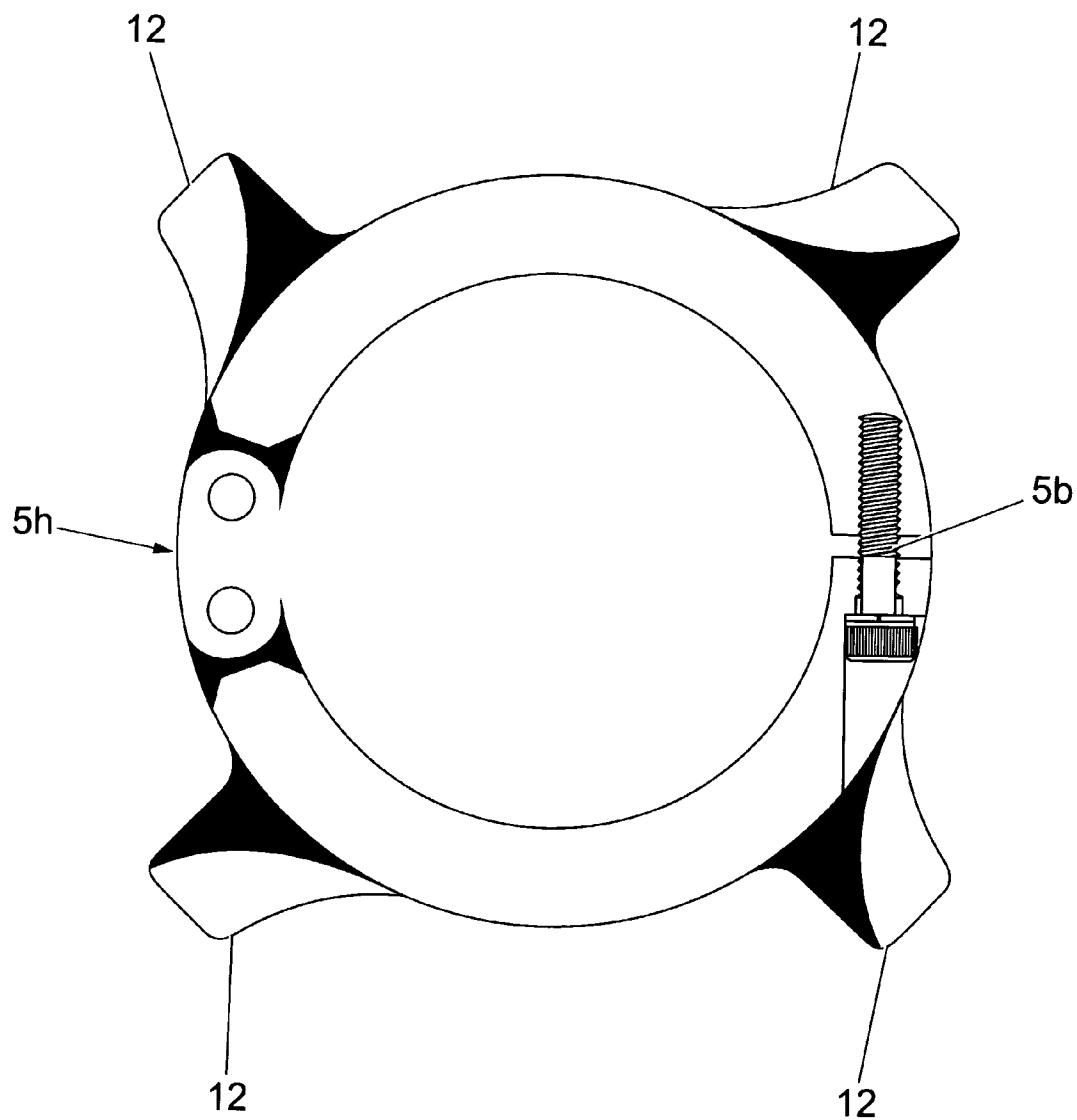

*Fig. 10*

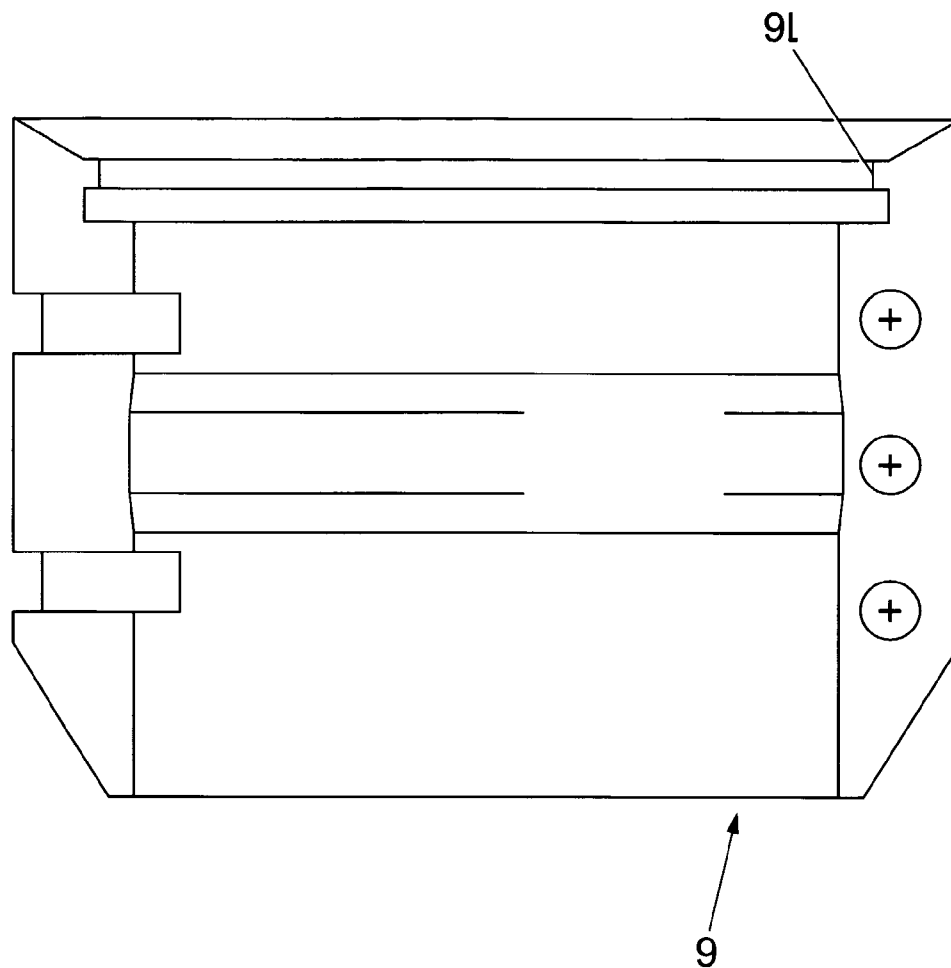

*Fig. 11*

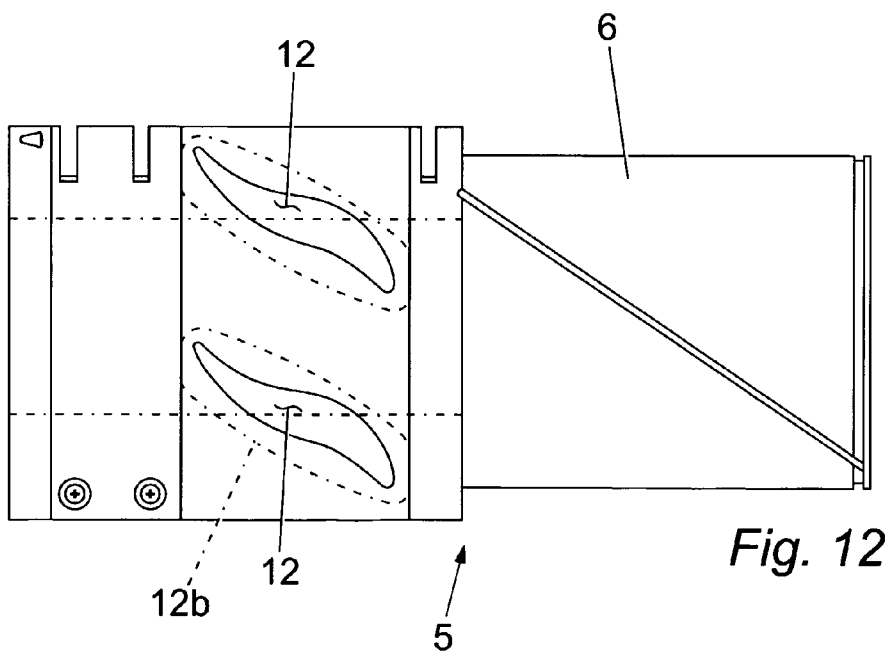
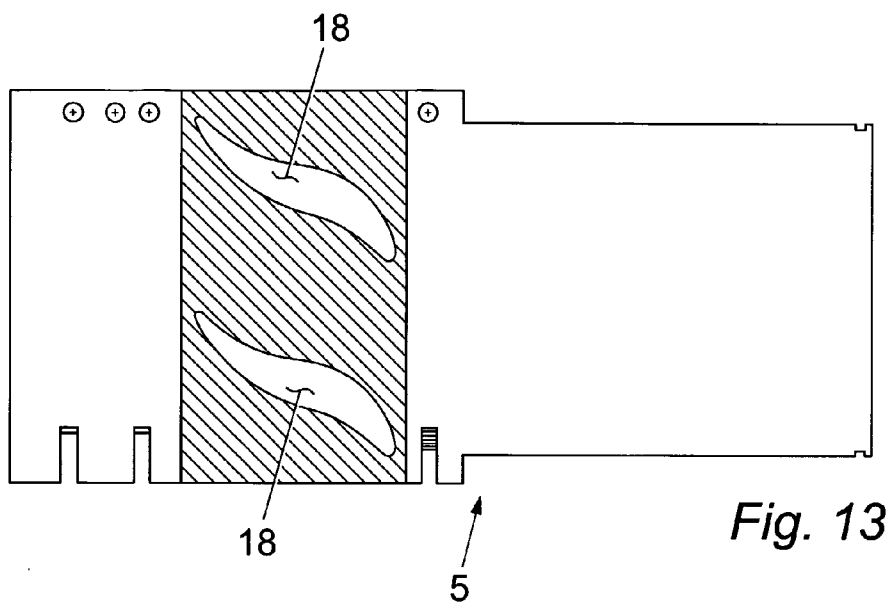



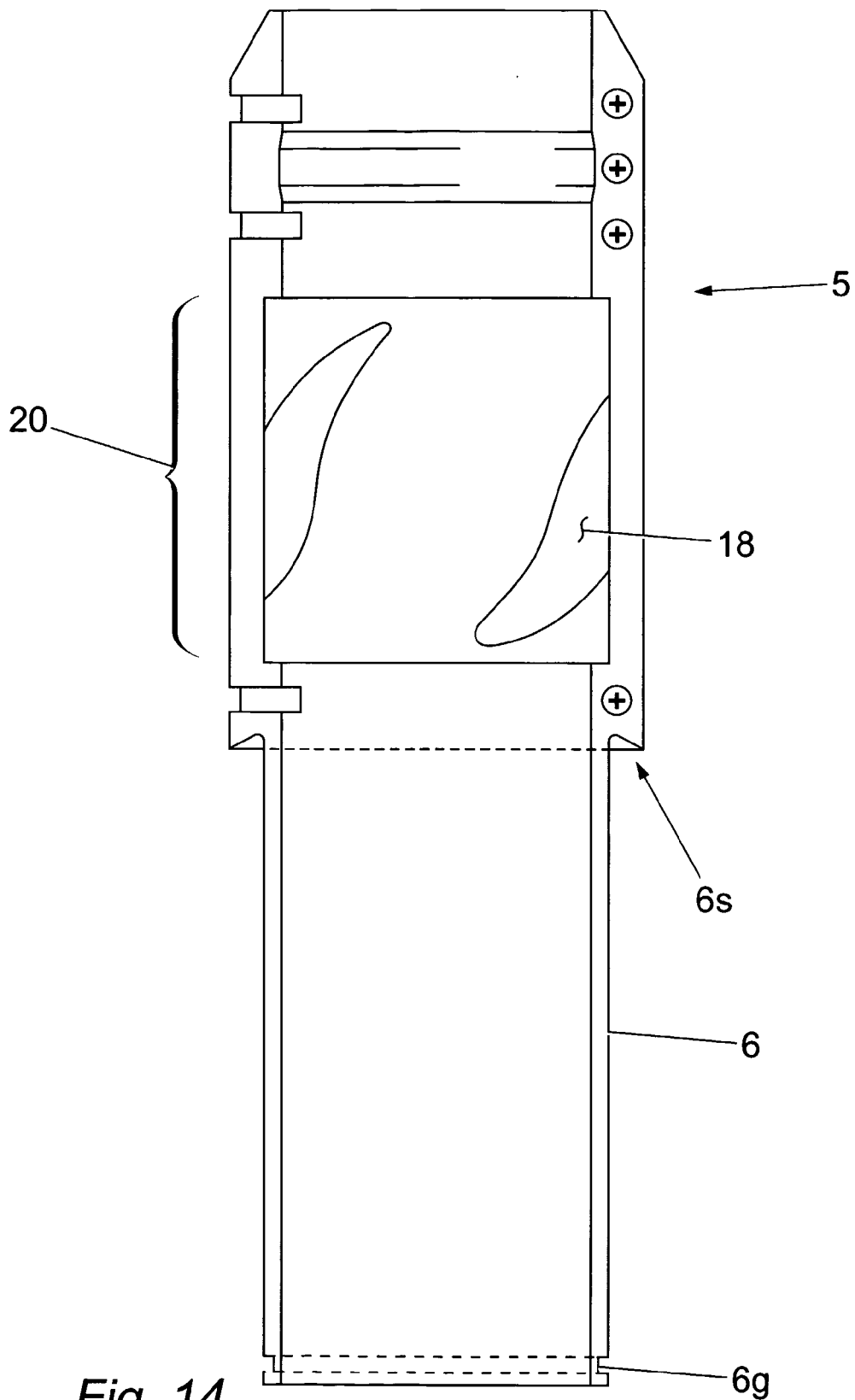
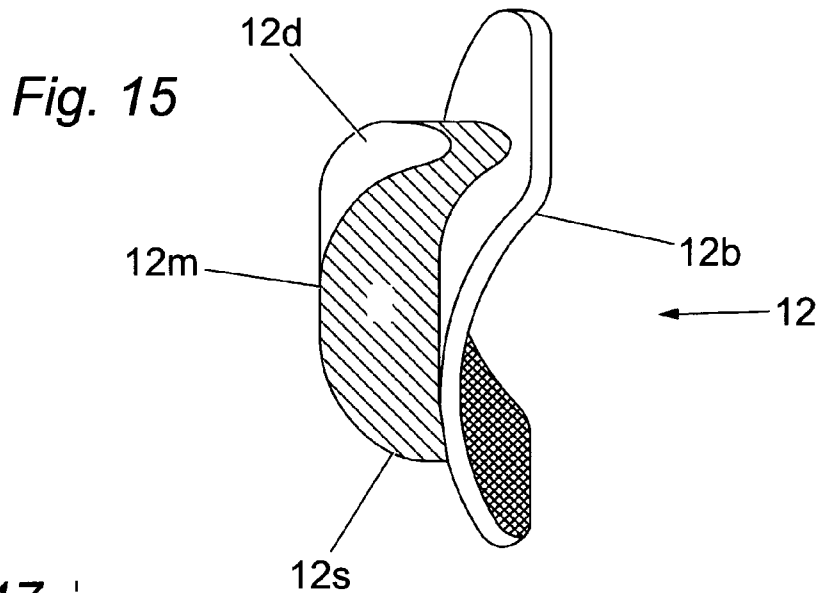
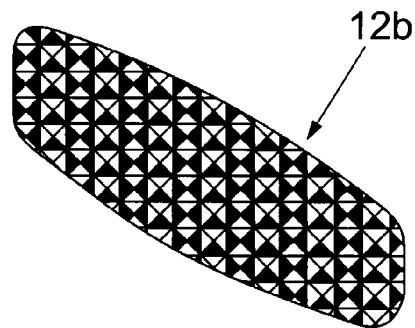
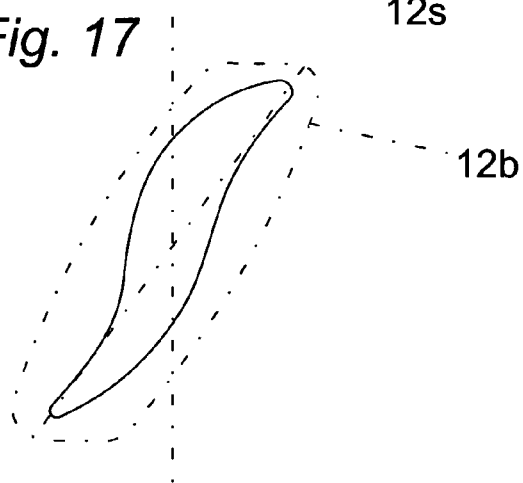

Fig. 14



**Fig. 17**



**Fig. 16**

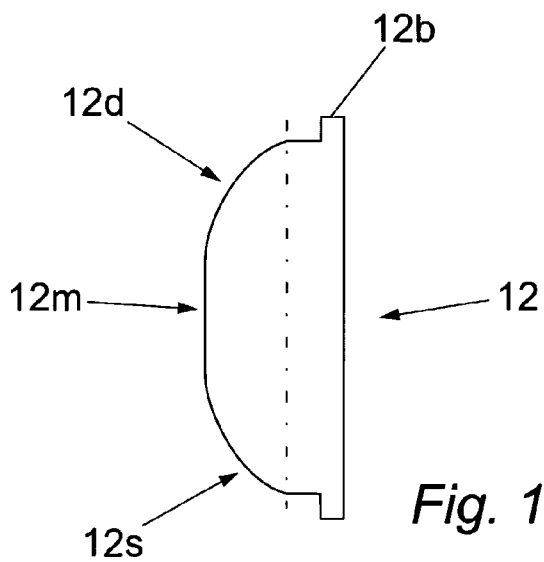

**Fig. 18**

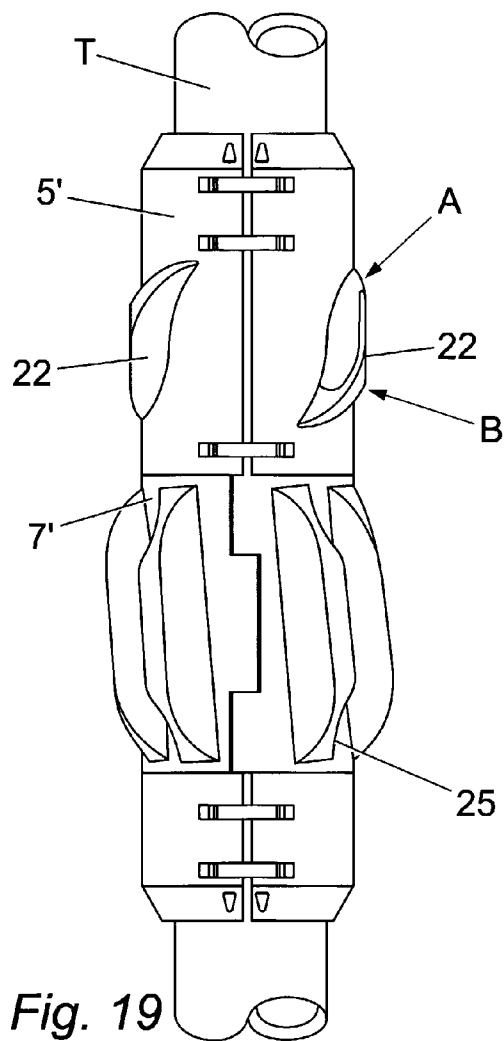

Fig. 19

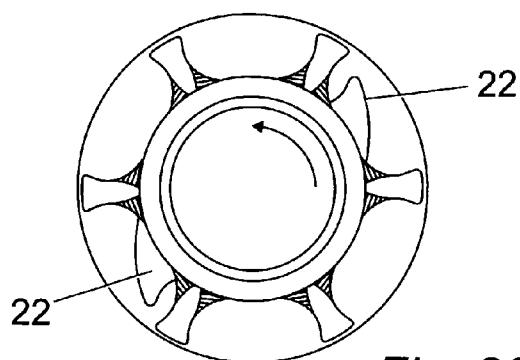

Fig. 20

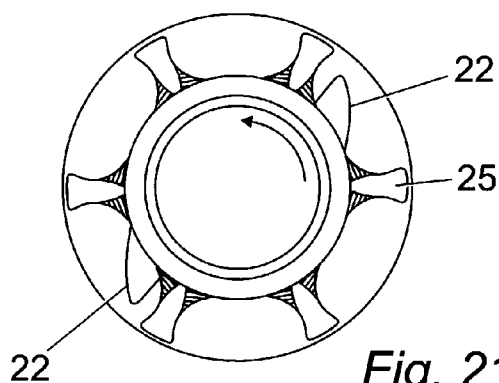

Fig. 21

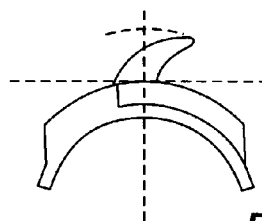

Fig. 22

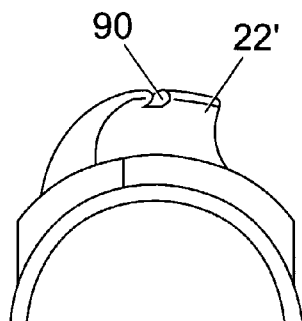

Fig. 24

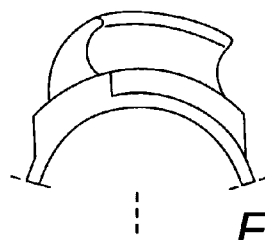

Fig. 23

### DOWNHOLE APPARATUS FOR MOBILISING DRILL CUTTINGS

[0001] The present invention relates to apparatus for mobilising drill cuttings in an oil or gas well.

[0002] The art of drilling wellbores for recovery of oil and gas is well known. One particular problem faced by this art is the removal of cuttings from the well as they are generated by the action of the drill bit cutting into the formation. The cuttings need to be removed from the bit and conveyed back to surface as efficiently as possible, as their persistence in the wellbore hampers drilling activity, and tends to reduce the productivity of the well.

[0003] Cuttings are washed back to surface by drilling mud or fluid pumped down the string, out through the bit, and back up the annulus surrounding the string. This solution is generally satisfactory, but in long and deviated wells we have found that cuttings still tend to clump and impede the drilling activity, or the production of the well.

[0004] According to the present invention there is provided apparatus for mobilising drill cuttings in a well, the apparatus comprising at least one vane, and two or more blades defining at least one fluid conduit between adjacent blades, the blades and vane being rotatable relative to one another.

[0005] Typically the blades are configured to create a pressure difference in fluid flowing through the conduit, but this is not essential, and a fluid drop, if required, can be induced by other means apart from the blades.

[0006] The apparatus typically comprises a sleeve or collar, which is typically tubular and is adapted to fit over a string in the well. The string can be a tubing string, drill string, or casing string etc. Typically the vanes are provided on the sleeve.

[0007] Typically the blades are mounted on a bushing that is rotatably mounted on the sleeve.

[0008] However, in certain simple embodiments, it is sufficient to provide the vanes direct on the tubing string (or on a sleeve attached to the string) and to provide the blades on an adjacent part of the string, or on a separate sleeve attached thereto, so that the blade-bearing bushing is not directly attached to the vane-bearing sleeve. The blades or the bushing can optionally be incorporated into a sub in the string, or on a collar that is separately attached to the string.

[0009] Typically the sleeve is adapted for attachment to a drill string, and the fixing means typically comprises a clamp means such as an annular clamp to fix the sleeve over the outer surface of the drill pipe. However, the sleeve may equally attach to casing or any other oilfield tubular goods.

[0010] The vanes can be carried direct on the sleeve, or in some embodiments can be provided on a separate bushing rotationally (or otherwise) affixed to the sleeve. The vanes typically rotate with the drill string in normal rotary drilling operations as they are typically rotationally fixed to the drill string. The rotation of the vanes agitates the fluid surrounding the apparatus, and creates thrust tending to drive the fluid past the sleeve. The blades of the bushing typically create a pressure drop in the fluid as it flows past the apparatus, driven by the rotation of the vane(s).

[0011] Typically the bushing is free to rotate relative to the sleeve, which is affixed to the drill string. Thus, upon rotation of the drill string (or casing) during normal rotary drilling, the bushing typically remains stationary relative to the wellbore, while the drill string rotates.

[0012] Typically the blades on the bushing project radially outward to a greater extent than the vanes of the sleeve, so that the radially outermost surface of the blades contacts the inner surface of the bore within which the string is located, and this centralises the sleeve within the bore. In preferred embodiments, the vanes are radially lower than the blades, and can freely rotate within the bore, as the higher blades provide a stand off against the inner surface of the bore. The bore can be the unlined wellbore, or can be the bore of casing, liner or other tubing in which the apparatus is located.

[0013] The blades can be set parallel to the axis, or can be offset with respect to it, so that they extend helically around the bushing. In some embodiments the blades are offset at an angle of 3-10° e.g. 5° from top left to bottom right with respect to the axis of the bushing. This orientation is useful in drillstrings that are conventionally rotated to the right, as the fluid path up the annulus tends to flow in a spiral from bottom right to top left at around 5° off the axis. Therefore, the offset blades do not substantially impede the fluid flow rate. Clearly adjustments can be made to the offset angle to suit the fluid flow direction in other wells.

[0014] The blades typically have an asymmetric profile, and in preferred embodiments the blades are shaped in the form of foils, so that the fluid conduits defined between adjacent blades on the bushing change in profile. Typically the fluid conduits are relatively narrow at a lower end (nearest the drill bit) and grow relatively wider toward the upper end (furthest away from the bit). The increase in dimension from the bottom of the channel to the top causes a pressure drop in the fluid flowing through the channel.

[0015] The blades can have profiled cross sections (i.e. end-on view) in the form of an hour glass, with a wide root radially innermost adjacent the bushing, a wide top at the radially outermost part of the blade that bears against the borehole wall, and a narrower cutaway portion between the two to facilitate fluid flow between the blades. This cutaway creates more space for the fluid to pass between the blades, and helps to avoid impedance of the fluid flow.

[0016] Typically the bushing can be formed from a rigid material, such as hard rubber or metal. The sleeve is typically formed from metal such as steel, alloy, aluminium, etc.

[0017] The sleeve can have an annular body to fit around a tubular or string of tubulars. The annular body can have the vanes integrally formed with it, for example by moulding the sleeve and vanes as a single piece. In alternative (and preferred) embodiments, the sleeve can have vane-receiving recesses therein to receive and retain modular vanes, which can be slotted in the recesses, and retained therein. This has the advantage that several different sizes of vanes can be used with a single sleeve.

[0018] Likewise, the blades on the bushing can be modular and can be received within blade recesses in the same manner.

[0019] The vanes can be curved or straight, and can lie parallel to the axis, but in typical embodiments they cross

the axis of the sleeve so as to scoop the fluid from the annulus. The lower end of the vane is typically circumferentially spaced around the sleeve from the upper end, typically in the direction of rotation of the string, so where the string rotates to the right (as is conventional in most wells) the vanes are offset across the axis from top right to bottom left, the opposite configuration from the offset blades described above.

[0020] In some embodiments the vanes are configured in a sinusoidal "lazy-s" shape and this helps to agitate the fluid surrounding the apparatus during rotation. In other embodiments, they are disposed straight across the axis.

[0021] The vanes can have concave surfaces to assist in the scooping action, and typically the concave surfaces can be provided in one side of the vane only, typically on the side of the vane facing the direction of rotation. The concave surface can be regular and unchanging along the side of the vane, but in some embodiments the side vane is shaped to have more of a curve on its upper end than on its lower end, so that as the fluid moves up the side of the vane, the increasing curve of the concave surface keeps the fluid close to the sleeve, where most turbulence will be generated, thereby keeping the cuttings in suspension for longer.

[0022] The or each vane can be provided with a notch cut away from a radially outermost portion of the vane. Several notches may be provided on each vane. The notches can serve to introduce additional turbulence or induce a vortex as the vane is rotated to agitate drill cuttings and entrain them into the flow of fluid up the annulus.

[0023] The invention also provides a drill cuttings agitation assembly, comprising a tubular, a vane, and at least two blades defining at least one fluid conduit between adjacent blades, wherein the vane and the blades are rotatable relative to one another.

[0024] The invention also provides a method of agitating drill fluid in an oil or gas well, the method comprising passing the drill fluid past a vane rotatable relative to at least two blades.

[0025] An embodiment of the invention will now be described by way of example and with reference to the accompanying drawings, in which:

[0026] FIG. 1 is a side view of apparatus according to the present invention, mounted on a tubular;

[0027] FIG. 2 is a close up side view of the FIG. 1 apparatus;

[0028] FIG. 3 is a side view of a sleeve of the FIG. 1 apparatus;

[0029] FIG. 4 is a side view of a bushing of a bushing of the FIG. 1 apparatus;

[0030] FIG. 5 is a side view of a clamp of the FIG. 1 apparatus;

[0031] FIGS. 6 and 7 (respectively) plan and underside views of the FIG. 4 bushing;

[0032] FIG. 8 is a flat view of a bushing half shell;

[0033] FIG. 9 is a side view of a bushing blade;

[0034] FIG. 10 is a plan view of a sleeve;

[0035] FIG. 11 is a sectional view through a clamp;

[0036] FIG. 12 is an outer side view of a second sleeve;

[0037] FIG. 13 is an inner side view of the second sleeve;

[0038] FIG. 14 is a sectional view through the second sleeve;

[0039] FIG. 15 is a perspective view of a modular vane for the second sleeve;

[0040] FIG. 16 is an underneath view of the FIG. 15 vane;

[0041] FIG. 17 is a plan view of the FIG. 15 vane;

[0042] FIG. 18 is a side view of the same vane;

[0043] FIG. 19 is a side view of a second embodiment of apparatus mounted on a tubular;

[0044] FIG. 20 is a sectional view from beneath the FIG. 19 apparatus at point A;

[0045] FIG. 21 is a sectional view from beneath the FIG. 19 apparatus at point B;

[0046] FIG. 22 is a plan of a vane;

[0047] FIG. 23 is a plan view of a second vane; and

[0048] FIG. 24 is a plan view of a vane having a cut-out portion.

[0049] Referring now to the drawings, apparatus for mobilising drill cuttings in a well comprises a sleeve 5, a bushing 7 and a clamp 9. All of these components are generally tubular, but are axially divided into two separate leaves that are hinged together. The leaves of the sleeve 5 are hinged at three locations 5h, and its two leaves pivot around those hinges to enable the sleeve 5 to be opened and closed around a tubular T such as drill pipe or casing. The two halves of the sleeve are locked together by one or more bolts 5b at a position diametrically opposite to the hinge 5h, so that the sleeve 5 can be tightly fastened to the tubular T by means of the bolts.

[0050] The hinges 5h are located on an upper part of the sleeve 5, beneath which is a bearing region 6 having a reduced outer diameter as compared with the nominal diameter of the upper region. An annular groove 6g is formed on the lower end of the bearing region 6, and a shoulder 6s divides the upper and bearing regions of the sleeve.

[0051] The bushing 7 is also formed as two separate leaves that are connected together at diametrically opposed positions by interlocking castellations and connecting pins 7p, about which the two leaves can pivot. The two leaves of the bushing 7 are typically closed around the bearing region 6 of the sleeve, at which point the leaves are connected together by inserting the pins 7p into axially aligned bores on the interlocking castellations to close and lock the bushing 7, so that the bushing 7 is connected to the sleeve 5.

[0052] After the bushing 7 has been locked in place around the bearing region 6 of the sleeve 5, the clamp 9 is then placed around the lower end of the bearing region 6, so that an annular lip on the internal surface of the clamp 9 engages in the external annular groove 6g on the lower part of the bearing region 6. The clamp 9 is then closed and fastened by means of bolts (not shown) in the same manner as the bolts 5b that lock the sleeve closed around the tubular T.

[0053] When thus assembled, the tightening of the bolts in the sleeve 5 and the clamp 9 securely connects the sleeve to the tubular, so that the two are rotationally connected, and thus the sleeve rotates with the tubular.

[0054] The bushing 7 is fixed to the bearing area 6 of the sleeve, and is prevented from axial movement by the shoulder 6s above it, and the clamp 9 below it; however, the bushing 7 is free to rotate around its axis relative to the sleeve and the clamp, and the tolerance of the outer diameter of the bearing region 6 and the inner diameter of the bushing 7 are chosen to permit a degree of play between the two, and allow rotation of the bushing 7 around the axis of the sleeve 5.

[0055] The sleeve 5 has vanes 12 mounted on the upper large diameter section. As best shown in FIG. 10, two vanes 12 are mounted on each leaf of the sleeve, and the vanes are spaced apart on the circumference of the assembled sleeve 5 at equal distances, so that the vanes 12 are arranged in diametrically opposed pairs.

[0056] The vanes 12 have a generally sinusoidal "lazy-S" shape with a lower scoop 12s, a generally axial mid-region 12m, and an upper deflector portion 12d.

[0057] In side profile, the vanes 12 are generally arcuate in the scoop and deflector regions, rising from the plane of the sleeve 5 in a regular arc until a plateau is reached at the mid-section 12m. FIG. 18 shows the side profile of a typical vane 12. The vanes 12 project radially from the outer surface of the sleeve 5, so as to create between adjacent vanes 12 a fluid path that is generally sinusoidal in shape.

[0058] The bushing 7 has blades 15. Typically, there are three blades arranged on each leaf of the bushing 7, and typically these are circumferentially spaced at equal distances, so that the blades 15 are arranged in three diametrically opposed pairs, as best shown in FIGS. 6 and 7. Each blade 15 is arranged generally parallel to the axis of the assembled bushing 7, and in plan view, each blade 15 is in the general shape of a foil or wing, as best shown in FIGS. 2 and 8. In detail, each blade 15 has a lower end 15l that widens from the lowermost tip of the blade to an apex 15a, from where it tapers through a mid-section 15m, to an upper end 15u, and finally to a slim point at the upper end. Shaping adjacent blades like foils in this manner creates a flow path between adjacent blades that rapidly narrows to a throat at the level of the apex 15a of the blades, and then gradually widens as the passage passes the upper ends 15u of the blades.

[0059] As best shown in FIG. 9, the side profile of each blade 15 rises from the plane of the bushing 7 at the tips and is arcuate in the upper 15u and lower 15l ends, and forms a plateau in the mid-section 15m.

[0060] The nominal external diameter of the bushing 7 is generally very close to the nominal external diameter of the upper part of the sleeve 5, and also matches that of the clamp 9, so that apart from the vanes 12 and the blades 15, there are no upsets on the outer surface of the apparatus.

[0061] The radial extent of the blades 15 typically exceeds the radial extent of the vanes 12, so that the mid-section 15m of the blades contacts the inner surface of the bore in which the apparatus is deployed, thereby spacing the vanes 12 from the inner surface of the bore.

[0062] In preferred embodiments, the blades 15 are integrally formed with the leaves of the bushing 7, and in typical embodiments, the two leaves can be cast or moulded each in a single piece with their respective blades. Alternatively, the blades can be formed separately and attached to the body of the bushing 7 as required.

[0063] The vanes 12 can also be cast or moulded integrally with the separate leaves of the sleeve, but in preferred embodiments, the vanes 12 (and optionally the blades 15) can be separately cast or otherwise formed from the same or a different material, and can be assembled with the sleeve prior to use in a modular fashion.

[0064] One such arrangement is shown in FIGS. 12 to 18.

[0065] In this embodiment, the sleeve 5 has a vane-receiving portion 20, which comprises a region with an increased inner diameter. Each vane 12 has a base plate 12b attached to its radially innermost face as shown in FIG. 15. The base plate 12b is curved, with an outer diameter that matches the inner diameter of a vane-receiving portion 20 of the sleeve.

[0066] When the sleeve 5 is to be assembled with the modular vanes 12, the radially outermost mid-portion 12m of each vane is offered to a vane-shaped slot 18 in the vane receiving portion 12, so that the mid-portion 12m passes from the inner surface of the sleeve 5 through the vane receiving slot 18, and extends radially outward from the outer surface of the sleeve 5. The curved radially outer face of the base plate 12b of each vane 12 matches the inner diameter of the vane receiving portion 20, and the depth of each base plate 12b is chosen to match the step between the nominal inner diameter of the sleeve 5 and the nominal inner diameter of the vane receiving portion 20, so that when the modular vanes are assembled with the sleeve 5, the base plates 12b are accommodated within the vane-receiving portion 20, and the inner diameter of the sleeve and base plate are contiguous. The assembled sleeve with modular vanes 12 can then be clamped onto the tubular T as previously described.

[0067] Modular vanes 12 give the advantage that worn vanes can be replaced easily, and different sizes or profiles of vanes 12 can be used with the same sleeve body. Also, vanes of different materials or properties can be provided on a generic sleeve 5, and if desired, modular vanes 12 having different characteristics can even be provided on the same sleeve 5.

[0068] It will be appreciated that modular blades 15 can be provided for the bushing 7 in the same way.

[0069] Typically the bushing 7 and blades 15 are formed from a hard material such as a hard rubber or plastic. Metals are also useful for the formation of the bushing 7, and aluminium, zinc alloy, or austempered ductile iron can be used for this purpose.

[0070] The sleeve 5 and vanes 12 need not be formed from the same material as the bushing 7 and blades 15, and in preferred embodiments, metals or plastics can be used for the vanes 12 and/or the sleeve 5.

[0071] In use, when the apparatus is clamped to a tubular T such as a drill string that is being used to drill a well, the device is typically deployed at regular intervals along the bore, and can be used from a position relatively close to the

drill bit right up to the top of the bore. The weight of the string T typically forces the mid-portion 15<sub>m</sub> of the blades 15 against the inner surface of the wellbore, so that the string is spaced away from the inner surface of the wellbore by the radial extent of the blades 15. Since the sleeve 5 is securely rotationally fastened to the drill string T, the sleeve 5 and hence the vanes 12 rotate in the direction of arrow A in FIG. 1, i.e. clockwise when viewed from the top of the string. However, since the weight of the string is pressing the blades 15 against the inner surface of the wellbore, and since the bushing 7 is rotatable on the bearing area 6, the bushing 7 remains stationary relative to the wellbore, and the sleeve and vanes 12 rotate relative to the bushing 7 along with the string.

[0072] The radial dimensions of the blades 15 exceed those of the vanes 12, and thus the vanes 12 are spaced from the inner surface of the bore, and are not impeded from rotating by contact with the inner surface of the wellbore. The rotation of the vanes 12 and the speed of the string (typically 120-180 rpm with normal rotary drilling, but sometimes as slow as 20 rpm with casing drilling) generates turbulence in the drill fluid in the annulus between the string and the wellbore. The sinusoidal arrangement of the vanes 12 generates thrust in the drill fluid in the region of the apparatus, and in particular, the scoops 12<sub>s</sub> drive the drill fluid up through the fluid passageways between adjacent vanes, and the deflectors 12<sub>d</sub> accelerate it out of the top of the fluid passage. In addition to creating thrust in the fluid and pumping the fluid from the lower end of the apparatus to the upper end, this also creates turbulence in the fluid, tending to break up clumps of drill cuttings, to keep the fluid in a liquid phase.

[0073] The rapid rotation of the vanes 12 in the drill fluid creates a pressure drop in the area between the vanes 12 and the blades 15, which draws more fluid up through the channels between adjacent blades 15. As the fluid passes the apex 15<sub>a</sub> in the channels between adjacent blades 15 on the stationary bushing 7, it experiences a further pressure drop created by the expansion in volume of the fluid passageway as each blade narrows towards its upper end. The pressure changes occurring as a result of this speeds up fluid flow from the bit to the surface, and also suspends cuttings in the liquid phase, which makes it easier to return them to surface.

[0074] An additional advantage of the non-rotating bushing 7 is that it reduces torque for rotation of the string T within the hole, and the bearing surface between the sleeve 5 and the bushing 7 is typically lubricated by the drill fluid passing the apparatus. In addition to this advantage, the smooth outer surface of the blades 15, and particular the rounded profile of the ends of the blades 15<sub>u</sub> and 15<sub>l</sub>, can reduce drag while running in the hole, thereby also reducing casing wear, and enhancing the penetration of the drill bit. If the bushing 12 is manufactured from materials having a low co-efficient of friction then additional advantages in running in the hole are also achieved. Notably, plastics, rubber and zinc alloys give useful secondary advantages in this respect.

[0075] The provision of the non-rotating bushing also reduces drill string harmonics, and can help to prevent differential sticking of the string.

[0076] FIG. 19 shows a further embodiment of apparatus for mobilising drill cuttings in a well comprising a sleeve 5',

a bushing 7' and a clamp 9' similar to that previously described for the first embodiment, and assembled onto the string T in the same way.

[0077] The sleeve 5' has vanes 22 mounted on the upper large diameter section. Only one vane 22 is mounted on each leaf of the sleeve, and the vanes are spaced apart on the circumference of the assembled sleeve 5' at equal distances, so that the vanes 22 are diametrically opposed to one another.

[0078] The vanes 22 are generally straight, but are attached to the sleeve 5' at an angle that is offset with respect to the axis of the sleeve 5', from top right to bottom left at around 5° wrt the axis. Each vane 22 typically has a concave surface on one side, typically that facing the direction of rotation, as best seen in FIG. 20. The concave surface typically acts as a scoop to create turbulence in the fluid flowing up the annulus between the sleeve 5' and the borehole. The radius of curvature of the concave surface changes with the axial position on the vane, as shown in FIGS. 20 and 21, so that at the lower end of the blade (see B in FIG. 19) the concave surface has a small curvature with the radially outermost part of the blade being nearly perpendicular to the tangent of the circumference of the sleeve 5'; whereas at the upper end of the blade (see A at FIG. 19) the radially outermost part of the blade is more curved and approaches a tangent to the circumference of the sleeve 5'. This graduation in the radius of curvature of the concave surface guides the fluid flowing past the vane 22 towards the sleeve 5', where turbulence and flow rates are highest, and this keeps the cuttings in suspension for longer.

[0079] In some other embodiments of vanes, the change in the radius of curvature is not required, and a simple regular concave surface as shown in FIGS. 22 and 23 will suffice. The vane shown in FIG. 22 can be modified by cutting out a small portion towards the centre of the radially outermost edge of the vane. Such an embodiment of a vane 22' is shown in FIG. 24. In an alternative embodiment, several notches 90 may be provided on the vane 22'. The notch 90 or notches can introduce additional turbulence or create a vortex to assist in the pick-up and agitation of drill cuttings to facilitate their inclusion in the flow regime.

[0080] The bushing 7' has blades 25. Typically, there are three blades arranged on each leaf of the bushing 7', and typically these are circumferentially spaced at equal distances, so that the blades 25 are arranged in three diametrically opposed pairs. Each blade 25 is offset at a 5° angle wrt the axis of the assembled bushing 7', from top left to bottom right, in an opposite configuration to the offset of the vanes 22.

[0081] In side profile, as shown in FIG. 19, each blade 25 comprises a central plateau region and radially lower ends. The width of the blades are consistent throughout their length unlike the earlier embodiments.

[0082] The nominal external diameter of the bushing 7' is generally very close to the nominal external diameter of the upper part of the sleeve 5', and also matches that of the clamp 9', so that apart from the vanes 22 and the blades 25, there are no upsets on the outer surface of the apparatus.

[0083] The radial extent of the blades 25 typically exceeds the radial extent of the vanes 22, so that the plateau sections

of the blades contact the inner surface of the bore in which the apparatus is deployed, thereby spacing the vanes 22 from the inner surface of the bore.

[0084] The blades 25 have profiled cross sections (i.e. end-on views) in the form of an hour glass as best shown in FIGS. 20 and 21, with a wide root radially innermost adjacent the bushing, a wide top at the radially outermost plateau of the blade that bears against the borehole wall, and a narrower cutaway portion radially between the two to facilitate fluid flow between the blades. This cutaway creates more space for the fluid to pass between the blades, and helps to avoid impedance of the fluid flow.

[0085] In use the operation of the second embodiment is similar to the first, but the vanes 22 keep the drill fluid and cuttings close to the wall of the sleeve as the scoops drive the drill fluid up through the fluid passageways between adjacent vanes. In addition to creating thrust in the fluid and pumping the fluid from the lower end of the apparatus to the upper end, this also creates turbulence in the fluid, tending to break up clumps of drill cuttings, to keep the fluid in a liquid phase.

[0086] Modifications and improvements can be incorporated without departing from the scope of the invention.

1. Apparatus for mobilizing drill cuttings in a well, comprising at least one vane, and at least two blades defining at least one fluid conduit between adjacent blades, the blades and vane being rotatable relative to one another.

2. Apparatus according to claim 1, wherein the blades are configured to create a pressure difference in a fluid flowing through the at least one fluid conduit.

3. Apparatus according to claim 1, comprising a sleeve adapted to fit over a drill string in the well.

4. Apparatus according to claim 3, wherein the at least one vane is provided on the sleeve.

5. Apparatus according to claim 1, wherein the blades project radially outward to a greater extent than the at least one vane.

6. Apparatus according to claim 3, wherein the blades are mounted on a bushing that is rotatably mounted on a sleeve.

7. Apparatus according to claim 3, wherein the sleeve has an axis of rotation, and wherein the blades are arranged substantially parallel to the axis of rotation of the sleeve.

8. Apparatus according to claim 6, wherein the bushing has an axis of rotation and wherein the blades are offset with respect to the axis of rotation of the bushing such that the blades extend helically around the bushing.

9. Apparatus according to claim 8, wherein the blades are offset at an angle of 3-10° with respect to the axis of rotation of the bushing.

10. Apparatus according to claim 3, comprising a fixing device for attaching the sleeve to the drill string.

11. Apparatus according to claim 10, wherein the fixing device comprises a clamp means.

12. Apparatus according to claim 11, wherein the clamp means comprise an annular clamp.

13. Apparatus according to claim 1, wherein the at least one vane is rotationally fixed to a drill string such that rotation of the drill string causes rotation of the at least one vane.

14. Apparatus according to claim 1, wherein the at least one vane is configured to create thrust when rotated in a fluid.

15. Apparatus according to claim 1, wherein the blades have an asymmetric profile.

16. Apparatus according to claim 1, wherein the blades are shaped in the form of foils, so that the fluid conduits defined between adjacent blades on the bushing change in profile between a first end proximal to the drill bit and a second end distal from the drill bit.

17. Apparatus according to claim 16, wherein the at least one fluid conduit is relatively narrow at the first end proximal to the drill bit and relatively wider towards the other end distal from the drill bit.

18. Apparatus according to claim 1, wherein the blades have a cross section in the form of an hour glass.

19. Apparatus according to claim 18, wherein the blades are shaped to have a wide root radially inner most adjacent the bushing, a wide top at the radially outermost part of the blade arranged to bear against the borehole wall, and a narrower cutaway portion between the root and top.

20. Apparatus according to claim 6, wherein the bushing is formed from a rigid material.

21. Apparatus according to claim 3, wherein the sleeve has an annular body to accommodate a tubular therethrough.

22. Apparatus according to claim 21, wherein the annular body has at least one vane integrally formed therewith.

23. Apparatus according to a claim 21, wherein the sleeve has at least one vane-receiving recess therein to receive and retain at least one modular vane.

24. Apparatus according to claim 6, wherein the bushing has blades integrally formed therewith.

25. Apparatus according to claim 6, wherein the bushing has blade-receiving recesses therein to receive and retain modular blades.

26. Apparatus according to claim 3, wherein the sleeve has an axis of rotation, and wherein the at least one vane lies parallel to the axis of rotation of the sleeve.

27. Apparatus according to claim 3, wherein the at least one vane is curved so as to scoop fluid from an area surrounding the vanes.

28. Apparatus according to claim 27, wherein the at least one vane is configured in a sinusoidal shape.

29. Apparatus according to claim 27, wherein the sleeve has an axis of rotation, and wherein the at least one vane is offset with respect to the axis of rotation of the sleeve such that one end of the at least one vane is circumferentially spaced around the sleeve from the other end.

30. Apparatus according to claim 29, wherein the direction of offset of the at least one vane is in an opposite direction to the offset of the blades.

31. Apparatus according to claim 1, wherein the at least one vane has a concave surface.

32. Apparatus according to claim 31, wherein the concave surface is provided on one side of the at least one vane facing the direction of rotation.

33. Apparatus according to a claim 32, wherein the side of the at least one vane is shaped to have a greater radius of curvature at one end than at another end.

34. Apparatus according to claim 1, wherein the at least one vane has one or more notches cut away from a radially outermost portion thereof.



**35.** A drill cuttings agitation assembly, comprising a tubular, at least one vane, and at least two blades defining at least one fluid conduit between adjacent blades, wherein the at least one vane and the blades are rotatable relative to one another.

**36.** A method of agitating drill fluid in an oil or gas well, the method comprising passing the drill fluid past at least one vane rotatable relative to at least two blades.

**37.** A method according to claim 36, including configuring the blades to create a pressure difference in fluid flowing through at least one fluid conduit defined by at least two blades.

**38.** A method according to claim 36, including providing the at least one vane on a sleeve.

**39.** A method according to claim 38, including providing blades on a bushing and rotatably mounting the bushing with respect to the sleeve.

**40.** A method according to claim 36, including mounting and rotationally fixing the at least one vane on a drill string.

**41.** A method according to claim 40, including rotating the drill string to rotate the at least one vane, thereby agitating the drill fluid in the environment.

**42.** A method according to claim 41, including centralizing the sleeve within a bore in which the drill string is located, by means of the blades.

\* \* \* \* \*