



US 20120257857A1

(19) **United States**
(12) **Patent Application Publication**
Kopp et al.

(10) **Pub. No.: US 2012/0257857 A1**
(43) **Pub. Date: Oct. 11, 2012**

(54) **HIGH DENSITY OPTICAL PACKAGING
HEADER APPARATUS**

Publication Classification

(75) Inventors: **Victor Il'ich Kopp**, Fair Lawn, NJ
(US); **Jonathan Singer**, New Hope,
PA (US); **Daniel Neugroschl**,
Suffern, NY (US)

(51) **Int. Cl.**
G02B 6/38 (2006.01)
(52) **U.S. Cl.** **385/71**

(73) Assignee: **CHIRAL PHOTONICS, INC.**,
Pine Brook, NJ (US)

(57) **ABSTRACT**

(21) Appl. No.: **13/442,175**

(22) Filed: **Apr. 9, 2012**

The inventive high density optical packaging header apparatus, in various embodiments thereof, provides configurable, modular, and highly versatile solutions for simultaneously connecting multiple optical fibers/waveguides to optical-fiber-based electronic systems, components, and devices, and is readily usable in a variety of applications involving highly flexible and modular connection of multiple optical fibers/waveguides assembled in a header block configuration to optical-fiber-based system/component backplanes, while providing advantageous active and passive alignment features.

Related U.S. Application Data

(60) Provisional application No. 61/433,852, filed on Apr. 8, 2011.

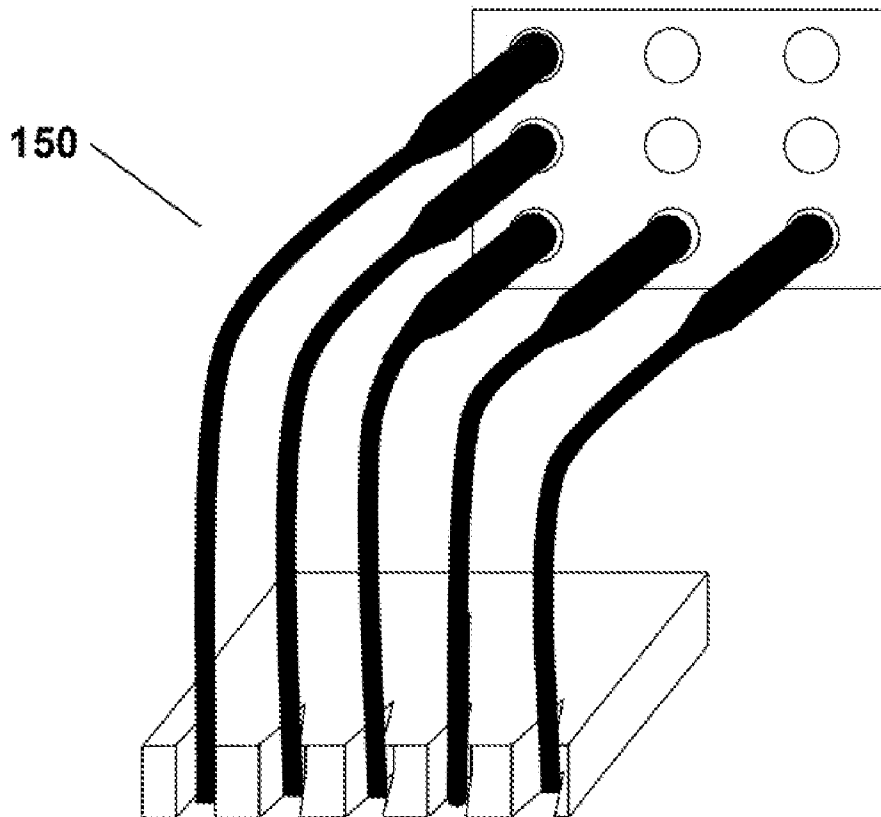

FIG. 1A

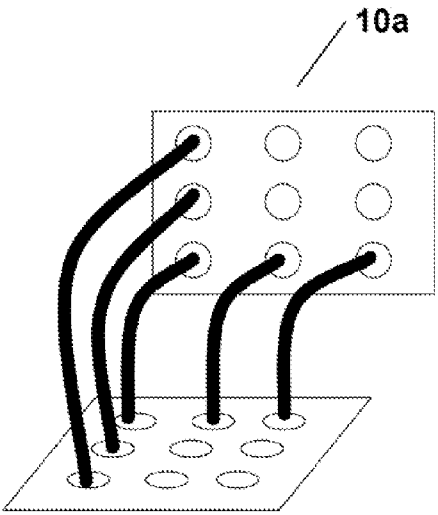

FIG. 1B

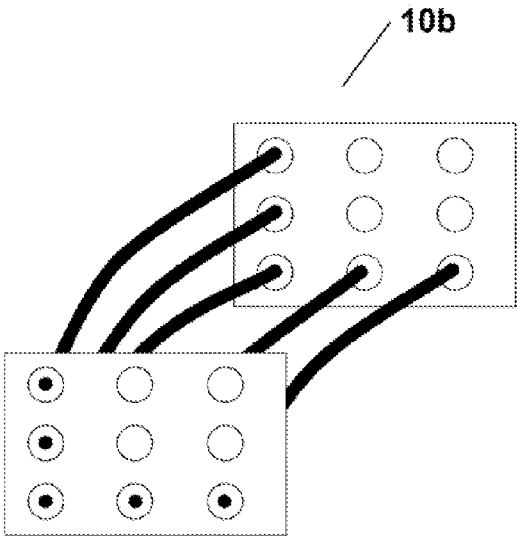

FIG. 2

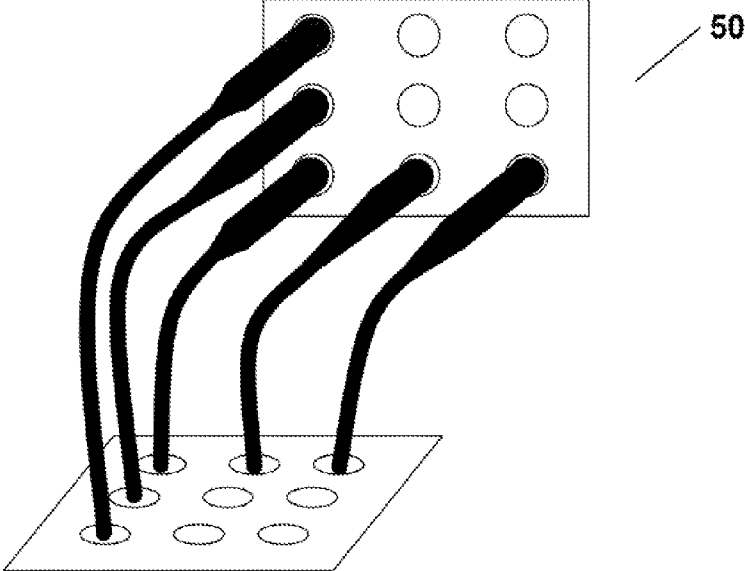

FIG. 3

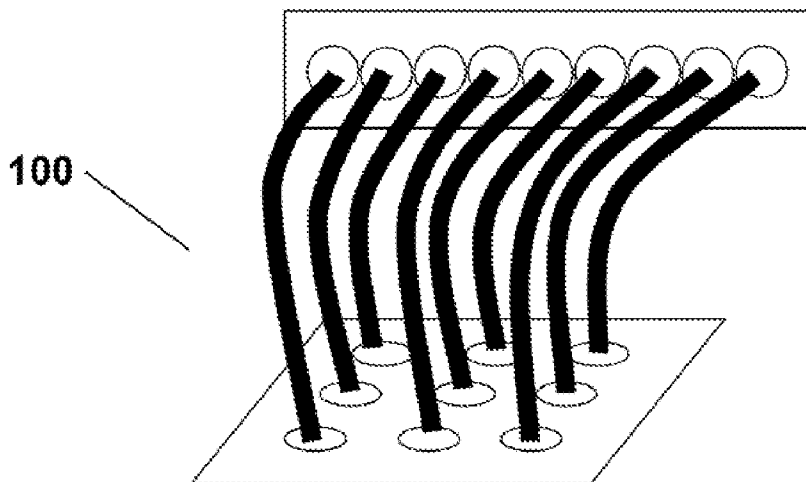

FIG. 4

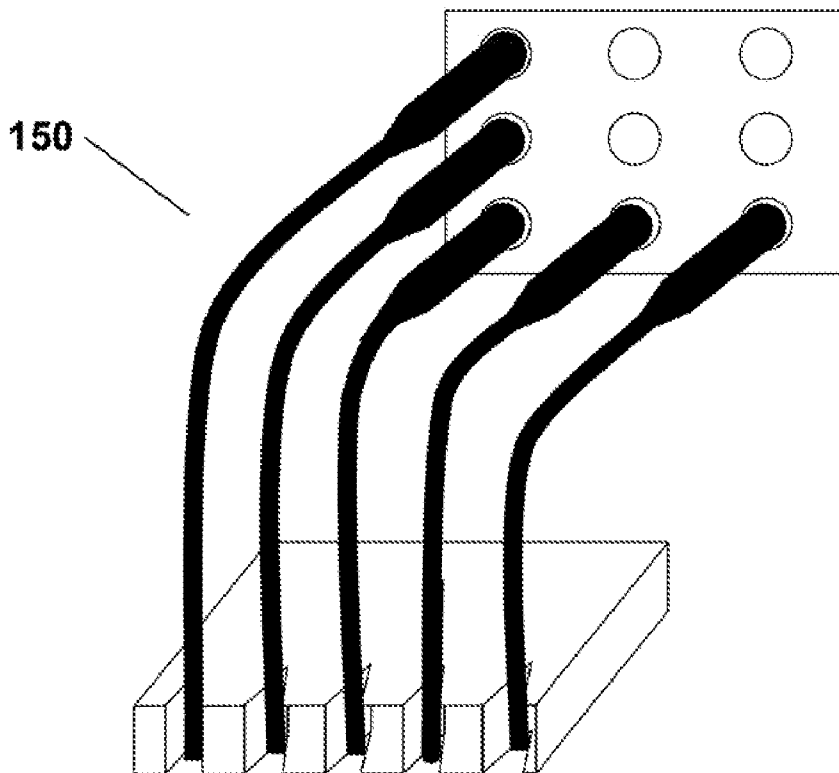

FIG. 5

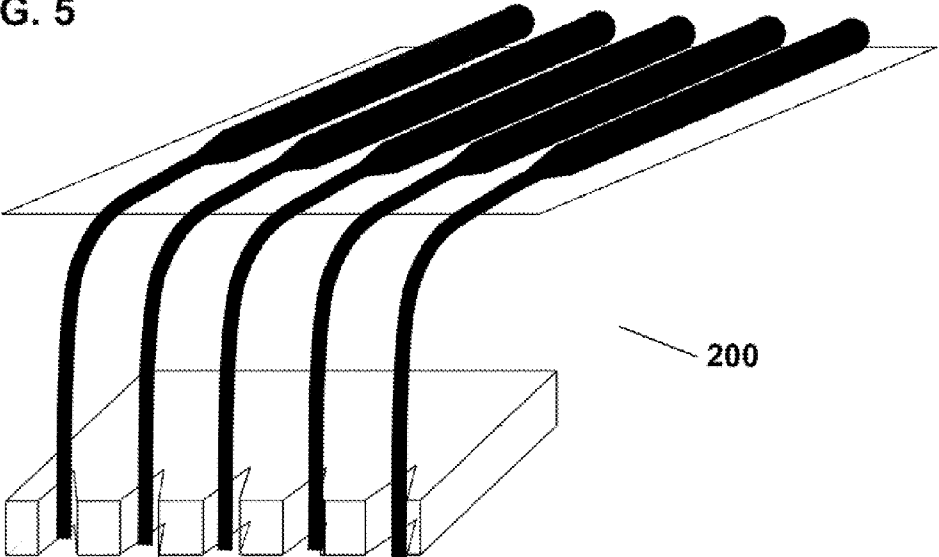

FIG. 6

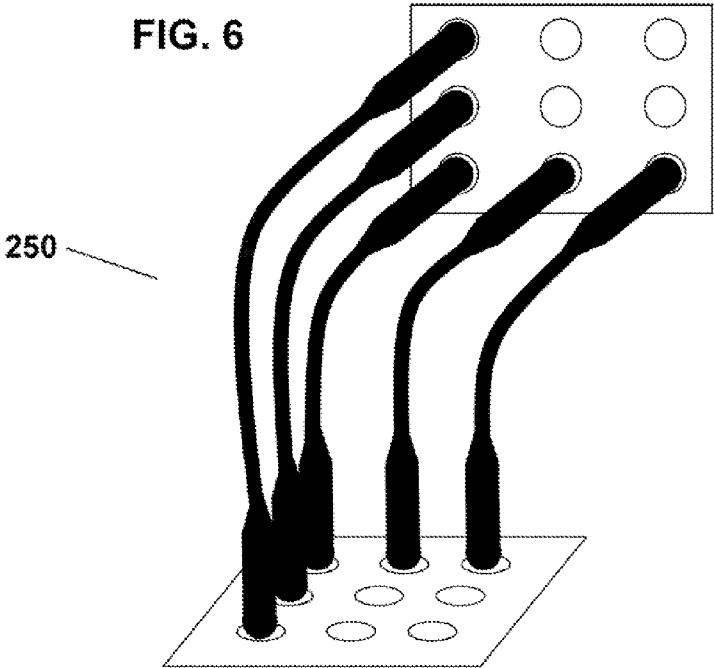
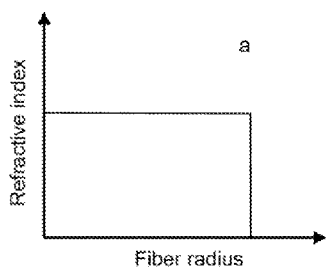

FIG. 7A



Multi-mode step index

300a

FIG. 7B

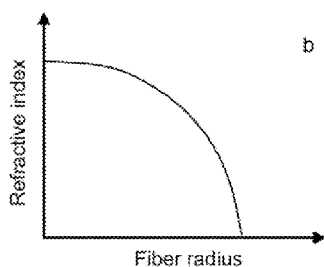

Multi-mode gradient index

300b

FIG. 7C

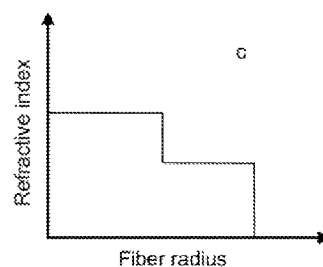

Single-mode multistep index
(at least one step)

300c

FIG. 8A

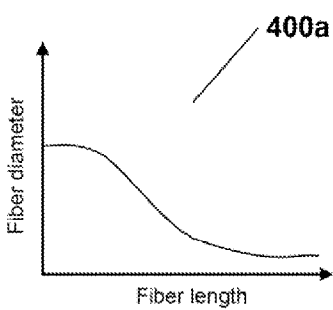

Single taper

FIG. 8B

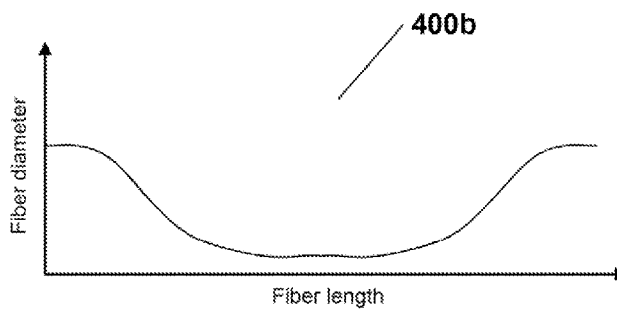

Dual taper

**HIGH DENSITY OPTICAL PACKAGING
HEADER APPARATUS**

**CROSS-REFERENCE TO RELATED
APPLICATIONS**

[0001] The present patent application claims priority from the commonly assigned co-pending U.S. provisional patent applications, Ser. No. 61/433,852, entitled “High Density Optical Packaging Header Apparatus”, filed Apr. 8, 2011.

FIELD OF THE INVENTION

[0002] The present invention relates generally to couplers and connectors for connecting multiple optical fibers/waveguides to optical-fiber-based electronic systems and components, and more particularly to a versatile optical packaging header apparatus that is readily configurable for use in a variety of applications involving highly flexible and modular connection of multiple optical fibers/waveguides assembled in a header block configuration to optical-fiber-based system/component/device backplanes, while providing advantageous active and passive alignment features.

BACKGROUND OF THE INVENTION

[0003] There are many applications in the field of electronic/optical systems, which require simultaneous connection of multiple optical fibers/waveguides to electronic/optical systems, components and devices, with high reliability and flexibility. Such requirements pose significant challenges due at least in part to:

[0004] the necessity of precise passive and active alignment of the connections (which is exacerbated when the connection involves multiple geometrically dispersed fibers/waveguides),

[0005] the inherent fragility of optical fibers/waveguides,

[0006] the need to match wave guidance value of the fibers/waveguides to numerical aperture or mode field diameter of the system/component/device interface, and

[0007] the need to match spatial configuration of the optical fibers/waveguides to the electronic/optical system/component/device backplane.

[0008] It would thus be desirable to provide a versatile and modular solution for simultaneously connecting multiple optical fibers/waveguides to electronic/optical systems, components, and devices that addresses the above-noted and other related challenges.

BRIEF DESCRIPTION OF THE DRAWINGS

[0009] In the drawings, wherein like reference characters denote corresponding or similar elements throughout the various figures:

[0010] FIGS. 1A to 5 show schematic diagrams of isometric views of various exemplary embodiments of the inventive high density optical packaging header (HDOPH) blocks for connection to optical components, each comprising at least one optical fiber waveguide;

[0011] FIGS. 7A to 7C show exemplary graphs, each representative of an exemplary embodiment of a different predetermined transverse refractive index distribution for use in configuring least one optical fiber waveguide in each of the various embodiments of the HDOPH blocks of FIGS. 1A to 5; and

[0012] FIGS. 8A to 8B show exemplary graphs, each representative of an exemplary embodiment of a different predetermined longitudinal diameter profile for use in configuring least one optical fiber waveguide in each of the various embodiments of the HDOPH blocks of FIGS. 1A to 5.

SUMMARY OF THE INVENTION

[0013] The present invention is directed to an inventive high density optical packaging header apparatus that, in various embodiments thereof, provides configurable, modular, and highly versatile solutions for simultaneously connecting multiple optical fibers/waveguides to optical-fiber-based electronic systems, components, and devices, and is readily usable in a variety of applications involving highly flexible and modular connection of multiple optical fibers/waveguides assembled in a header block configuration to optical-fiber-based system/component backplanes, while providing advantageous active and passive alignment features.

[0014] Other objects and features of the present invention will become apparent from the following detailed description considered in conjunction with the accompanying drawings. It is to be understood, however, that the drawings are designed solely for purposes of illustration and not as a definition of the limits of the invention, for which reference should be made to the appended claims.

DETAILED DESCRIPTION OF THE INVENTION

[0015] The apparatus of the present invention advantageously overcomes and address the drawbacks of previously known solutions for simultaneously connecting multiple optical fibers/waveguides to optical-fiber-based systems, components, and devices, and provides additional beneficial features.

[0016] Specifically, the inventive high density optical packaging header apparatus, in various embodiments thereof, provides configurable, modular, and highly versatile solutions for simultaneously connecting multiple optical fibers/waveguides to optical-fiber-based electronic systems, components, and devices, and is readily usable in a variety of applications involving highly flexible and modular connection of multiple optical fibers/waveguides assembled in a header block configuration to optical-fiber-based system/component backplanes, while providing advantageous active and passive alignment features.

[0017] Before describing the various exemplary embodiments of the present invention, the term “wave guidance parameter(s)” of a waveguide as utilized herein, may indicate either (1) numerical aperture(s) thereof, or (2) mode field diameter(s) thereof. It should be noted that a higher wave guidance parameter value of a waveguide region corresponds to a higher numerical aperture value and a lower mode field diameter value in that region and also indicates that the waveguide region is less susceptible to bend loss (in the case when the waveguide is bent). Conversely, a lower wave guidance parameter value of a waveguide region corresponds to a lower numerical aperture value and a higher mode field diameter value in that region and also indicates that the waveguide region is more susceptible to bend loss (in the case when the waveguide is bent).

[0018] The apparatus of the present invention, in at least one exemplary embodiment thereof, comprises a set of high density optical packaging header (HDOPH) blocks for con-

necting optical components (e.g., cards, boards, or equivalents thereof), which assemble and retain a set of optical fibers to optical backplane, either in a straight position (e.g., 180 degrees), or positioned at a predefined angle (e.g., at a right (90 degree) angle). The optical fiber waveguides in these components can be optical fibers, and/or other optical fiber waveguides of differing wave guidance values, and/or having different spatial positions/configurations. In at least some embodiments of the present invention, one or more of the optical fiber waveguides may comprise at least one of optical fiber coupler, such as disclosed in the commonly assigned U.S. Pat. No. 7,308,173 entitled "OPTICAL FIBER COUPLER WITH LOW LOSS AND HIGH COUPLING COEFFICIENT AND METHOD OF FABRICATION THEREOF", which is hereby incorporated by reference herein in its entirety.

[0019] One of the key aspects of the present invention is the capability of configuring the optical fiber waveguide components of the novel HDOPH block arrays to comprise specific desirable waveguide parameter value(s) at one or both ends thereof (which may be the same, or which may differ between one or more waveguides in a particular inventive HDOPH block array) with at least a portion of the waveguides being connected to at least one fiber port of at least one optical fiber header block. This is advantageously accomplished for each waveguide by utilizing an optical fiber waveguide having a capacity for at least one optical mode of a predetermined mode field profile, and comprising, along at least a portion of its length, a particular predetermined transverse refractive index distribution and a particular predetermined longitudinal diameter profile, wherein the particular predetermined transverse refractive index distribution and the particular predetermined longitudinal diameter profile are selected and configured to predetermine at least one wave guidance parameter value over at least one region along the optical fiber waveguide for any propagating light signal, launched into the at least one optical mode of the optical fiber waveguide (e.g., from a fiber port connected to one end thereof).

[0020] Referring now to FIGS. 7A-7C, various exemplary embodiments of predetermined transverse refractive index distributions that may be selected and configured for one or more optical fiber waveguides in accordance with the present invention, are shown, by way of example only, as a multi-mode step index distribution **300a** (FIG. 7A), a multi-mode gradient index distribution **300b** (FIG. 7B), and/or a single-mode multi-step index distribution **300c** (FIG. 7C). It should be noted that transverse refractive index distributions other than as is shown in FIGS. 7A to 7C may be readily selected as a matter of design choice without departing from the spirit of the invention.

[0021] Referring now to FIGS. 8A-8B, various exemplary embodiments of predetermined longitudinal diameter profiles, that may be selected and configured for one or more optical fiber waveguides in accordance with the present invention, are shown, by way of example only, as a single taper diameter profile **400a** (FIG. 8A), or as a dual taper diameter profile **400b** (FIG. 8B). It should be noted that longitudinal diameter profiles other than as is shown in FIGS. 8A to 8B may be readily selected as a matter of design choice without departing from the spirit of the invention.

[0022] It should further be noted that in various exemplary embodiments of the present invention, the predetermined transverse refractive index distribution and the predetermined longitudinal diameter profile, may be selected and config-

ured, for at least one selected optical fiber waveguide in an inventive HDOPH block array such that: (a) the optical fiber waveguide diameter and wave guidance parameter values thereof are correlated, or (b) the optical fiber waveguide diameter and wave guidance parameter values thereof are inversely correlated.

[0023] In various inventive embodiments thereof, the novel HDOPH blocks (e.g., and HDOPH block arrays, as may be applicable) may comprise one or more of the following advantageous features/elements:

[0024] Referring now to FIGS. 1A-1B, the inventive HDOPH blocks may be constructed of precision made plates with holes (drilled, etched, and/or otherwise formed) that can be glued or fused in perpendicular configurations (such as a HDOPH block array assembly **10a** of FIG. 1A), or in parallel configurations (such as a HDOPH block array assembly **10b** of FIG. 1B).

[0025] Referring now to FIGS. 2 and 3, the inventive HDOPH blocks may be configured with spot-size converting properties, for example utilizing tapered 3-glass fibers to convert wave guidance values (e.g. in a similar manner to arrayed spot-size converting tapered coupler).

[0026] However, in accordance with the present invention, the orientation of the array can be intentionally changed/transitioned as desired. For example, as is shown for an exemplary embodiment of the present invention—a HDOPH block array assembly **100** of FIG. 3—a 1D HDOPH block array may be readily transitioned to a 2D HDOPH block array or a 1D HDOPH block array may be transitioned to another 1D HDOPH block array, but with different fiber spacing.

[0027] Referring now to FIGS. 4 and 5, the inventive HDOPH blocks can be used as an angled transition (e.g., for a 90 degree angle transition), as is shown for a HDOPH block array assembly **150** of FIG. 4.

[0028] For example, HDOPH blocks can use a reduced (e.g., tapered) 3-glass fiber therebetween to achieve a minimal bend radius (essentially, the tapered region between the blocks gives the entire connection system great flexibility, while conventional fibers cannot be bent with an equivalently short bend radius).

[0029] Furthermore, the orientation of the HDOPH block array used for an angled transition can be intentionally changed/transitioned as desired. For example, as is shown for an exemplary embodiment of the present invention—a HDOPH block array assembly **200** of FIG. 5—a 1D HDOPH block array may be readily transitioned to a 2D HDOPH block array or a 1D HDOPH block array may be transitioned to another 1D HDOPH block array but with different fiber spacing.

[0030] If the waveguide sizes and orientation remain the same for a particular connection configuration, multiple inventive HDOPH blocks may be readily and efficiently produced by guiding multiple fibers through multiple plates simultaneously, and then fusing and polishing waveguides (i.e., through a single fiber insertion step).

[0031] Inventive HDOPH blocks may be configured as being connected permanently to backplane or plug-in cards.

[0032] Optical components can be injection molded with, for example, spring wires, zirconia sleeves, or equivalents, for coupling to optical waveguides or fibers, respectively.

[0033] Inventive HDOPH blocks may be configured with a plurality of channels (holes), some of which may be utilized for receiving and retaining optical fibers, while others may be left empty for use with passive alignment elements, thus enabling fabrication of a passive alignment—enabled optical fiber connection system in a single process step.

[0034] The inventive HDOPH blocks may be configured with one wave guidance parameter value at one end and the same or other wave guidance parameter value at the other end, as is shown, by way of example for a HDOPH block array assembly 250 of FIG. 6.

[0035] The fiber ports of various embodiments of the inventive HDOPH blocks may comprise holes and/or V-grooves (as shown in FIGS. 4 and 5).

[0036] Thus, while there have been shown and described and pointed out fundamental novel features of the inventive apparatus as applied to preferred embodiments thereof, it will be understood that various omissions and substitutions and changes in the form and details of the devices and methods illustrated, and in their operation, may be made by those skilled in the art without departing from the spirit of the invention. For example, it is expressly intended that all combinations of those elements and/or method steps which perform substantially the same function in substantially the same way to achieve the same results are within the scope of the invention. It is the intention, therefore, to be limited only as indicated by the scope of the claims appended hereto.

We claim:

1. An optical fiber array assembly for use with a multi-channel optical waveguide device, comprising:
 - at least one optical fiber header block, having a plurality of fiber ports, and
 - a plurality of separate individual optical fiber waveguides each having a capacity for at least one optical mode of a predetermined mode field profile, wherein at least one end of each said plural optical fiber waveguide is attached to a corresponding plural fiber port, wherein each said plural optical fiber waveguide comprises a particular predetermined transverse refractive index distribution and a particular predetermined longitudinal diameter profile, and wherein each particular predetermined transverse refractive index distribution and each particular predetermined longitudinal diameter profile along said optical fiber waveguide, are selected and configured to predetermine at least one of a plurality of wave guidance parameter values at a plurality of locations along said plural optical fiber waveguide for any propagating light signal, launched from each said plural fiber port into said at least one optical mode of said corresponding plural optical fiber waveguide.
2. The optical fiber array assembly of claim 1, wherein said wave guidance parameter is selected from one of: numerical aperture, and mode field diameter.

3. The optical fiber array assembly of claim 1, wherein said predetermined transverse refractive index distribution and said predetermined longitudinal diameter profile are selected and configured, for at least one selected plural optical fiber waveguide, such that diameter and wave guidance parameter values thereof are correlated.
4. The optical fiber array assembly of claim 1, wherein said predetermined transverse refractive index distribution and said predetermined longitudinal diameter profile are selected and configured, for at least one selected plural optical fiber waveguide, such that diameter and wave guidance parameter values thereof are inversely-correlated.
5. The optical fiber array assembly of claim 1, wherein at least one of said plural fiber ports comprises a hole.
6. The optical fiber array assembly of claim 1, wherein at least one of said plural fiber ports comprises a V-groove.
7. The optical fiber array assembly of claim 1, wherein at least one of said plural optical fiber waveguides is substantially straight in a region along its length corresponding to a first wave guidance parameter value, and is substantially bent in a region along its length corresponding to a higher wave guidance parameter .
8. The optical fiber array assembly of claim 1, wherein each said plural optical fiber waveguide is attached to said plural fiber ports of said optical fiber header blocks at both ends thereof.
9. The optical fiber array assembly of claim 1, further comprising:
 - a substrate, oriented at a predefined angle with respect to said plural fiber ports of said optical fiber header block, sized and configured to support said plural optical fiber waveguides.
10. The optical fiber array assembly of claim 9, wherein said predefined angle comprises 90 degrees.
11. An optical fiber array assembly for use with a multi-channel optical waveguide device, comprising:
 - at least one optical fiber header block, having at least one fiber port, and
 - an optical fiber waveguide having a capacity for at least one optical mode of a predetermined mode field profile, wherein at least one end of said optical fiber waveguide is attached to a corresponding at least one fiber port, wherein said optical fiber waveguide comprises a particular predetermined transverse refractive index distribution and a particular predetermined longitudinal diameter profile, and wherein said particular predetermined transverse refractive index distribution and said particular predetermined longitudinal diameter profile along said optical fiber waveguide fiber, are selected and configured to predetermine at least one of a plurality of wave guidance parameter values at a plurality of locations along said optical fiber waveguide for any propagating light signal, launched from said at least one fiber port into said at least one optical mode of said optical fiber waveguide.
12. The optical fiber array assembly of claim 10, wherein said wave guidance parameter is selected from one of: numerical aperture, and mode field diameter.

* * * * *