



US 20060256539A1

(19) **United States**

(12) **Patent Application Publication**

Mori et al.

(10) **Pub. No.: US 2006/0256539 A1**

(43) **Pub. Date: Nov. 16, 2006**

(54) **UNIVERSAL SERIAL BUS HUB AND METHOD OF MANUFACTURING SAME**

Publication Classification

(75) Inventors: **Kenneth Mori**, Los Angeles, CA (US);
Ernesto Quinteros, Los Angeles, CA (US)

(51) **Int. Cl.**
H05K 5/00 (2006.01)
(52) **U.S. Cl.** **361/752**

Correspondence Address:
Bryan Cave, LLP
Suite 2200
2 North Central Avenue
Phoenix, AZ 85004 (US)

(57) **ABSTRACT**

(73) Assignee: **Belkin Corporation**, Compton, CA

(21) Appl. No.: **11/489,993**

(22) Filed: **Jul. 19, 2006**

A universal serial bus hub (100, 700) includes a housing (110) having a top portion (111), a bottom portion (211) opposite the top portion, a first side (112) between the top portion and the bottom portion, and a first universal serial bus port (120) at the top portion. Various embodiments include a second side (113) between the top portion and the bottom portion, a second universal serial bus port (210) at the second side, as many as six or more universal serial bus ports at a side, or a combination thereof. In certain embodiments, ports are arranged in a line or horizontally, a seventh port is provided, a status indicator, translucent material, or rubberized material are provided, or a combination thereof.

Related U.S. Application Data

(63) Continuation of application No. 10/649,997, filed on Aug. 26, 2003.

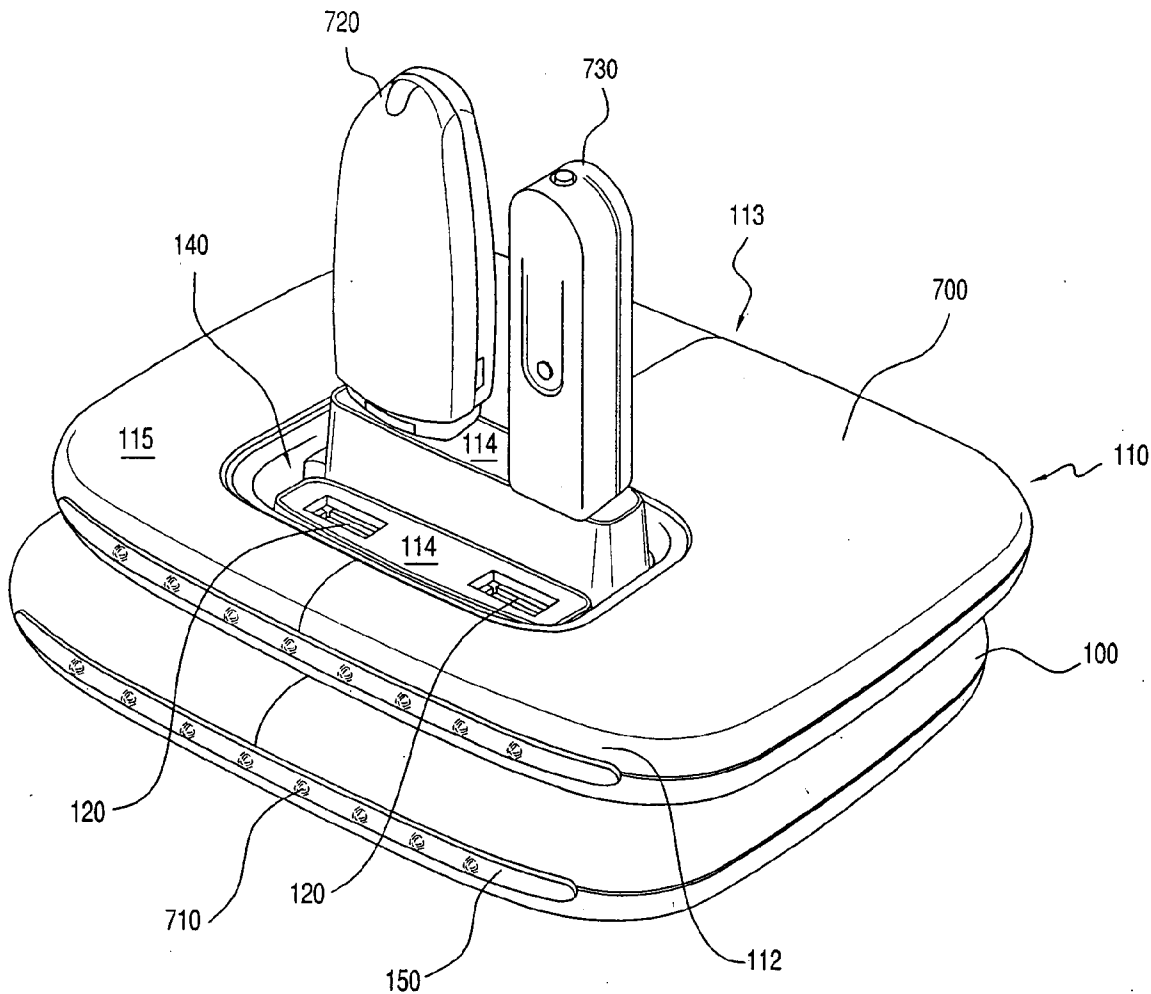

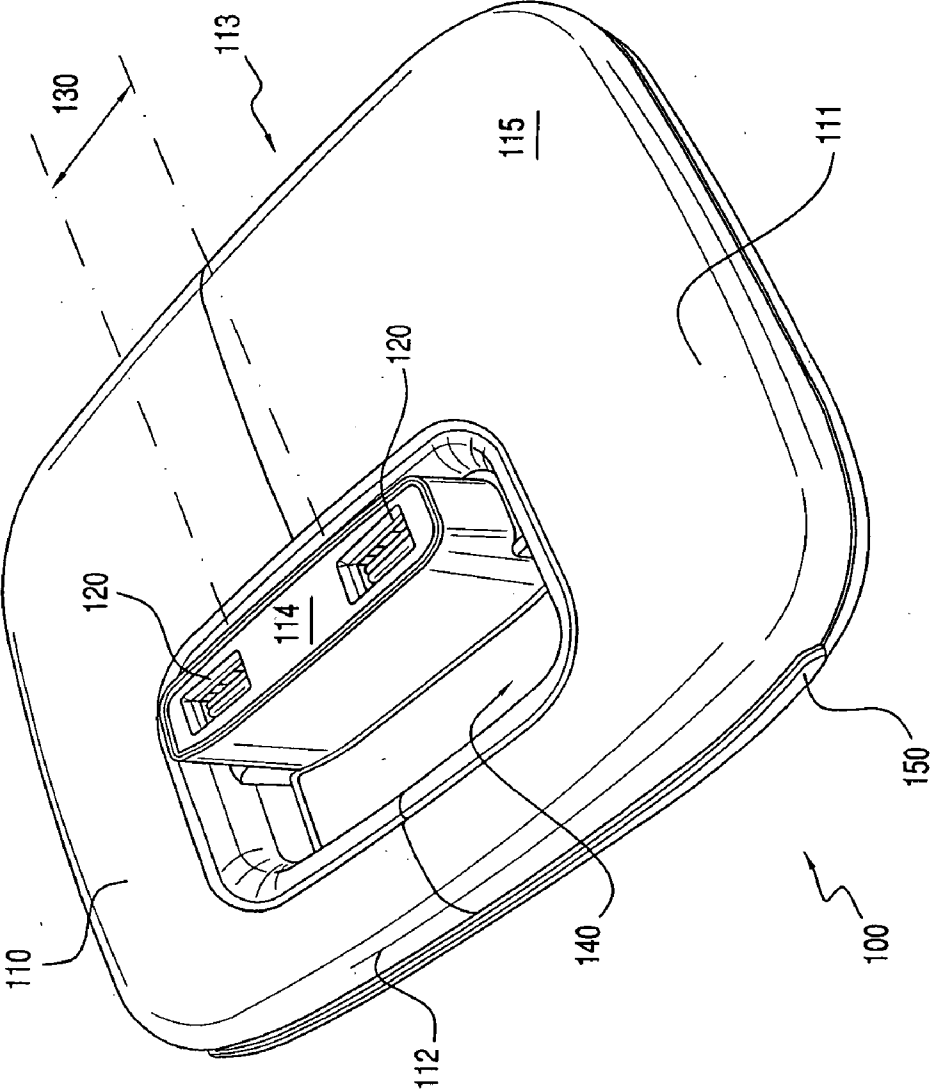

FIG.1

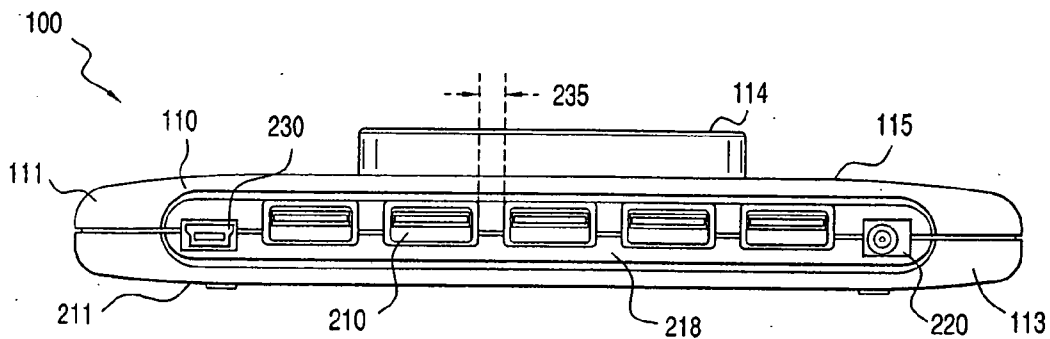

FIG. 2

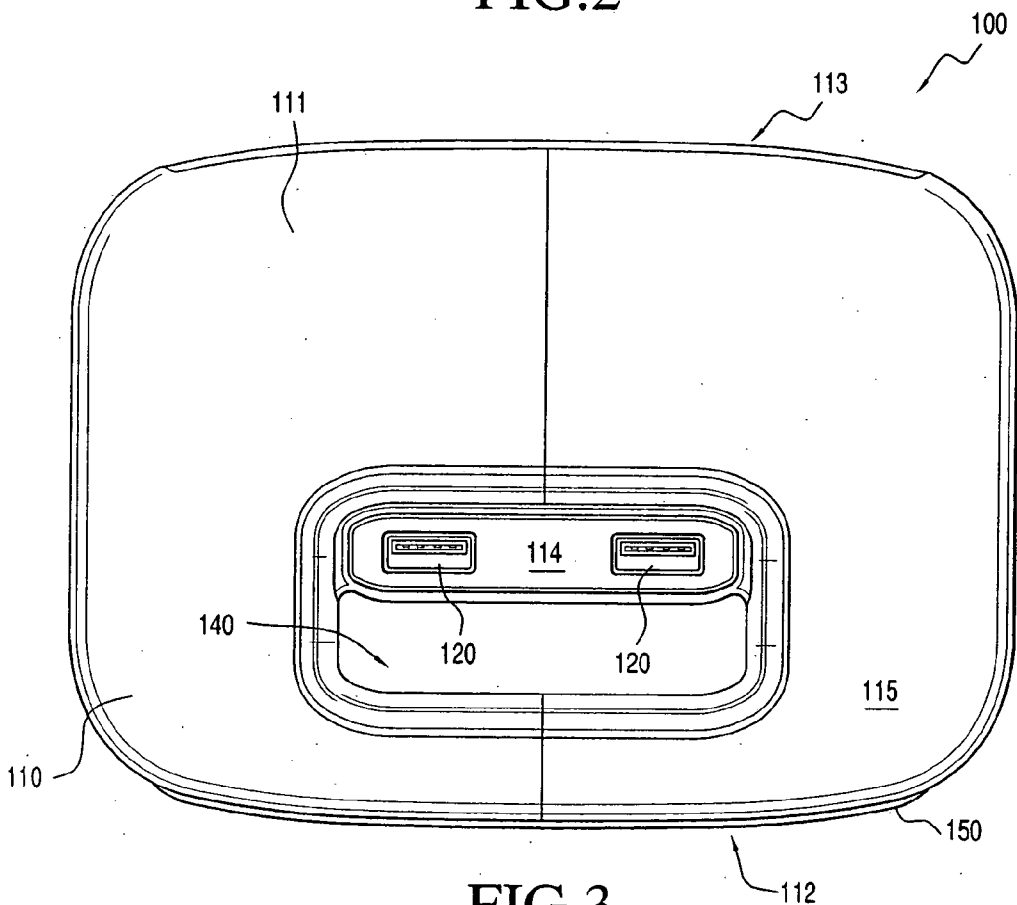

FIG. 3

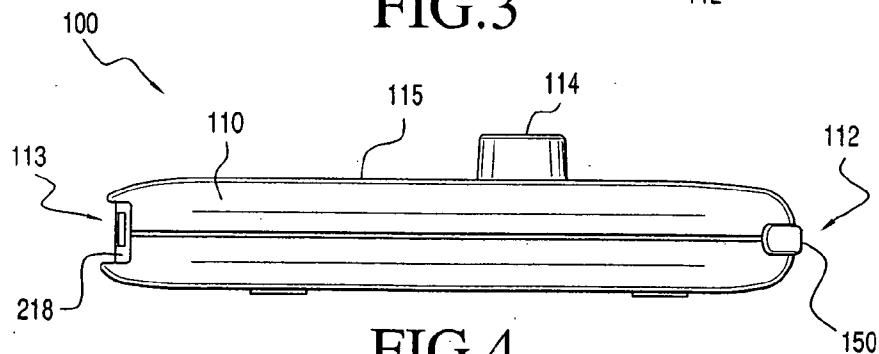

FIG. 4

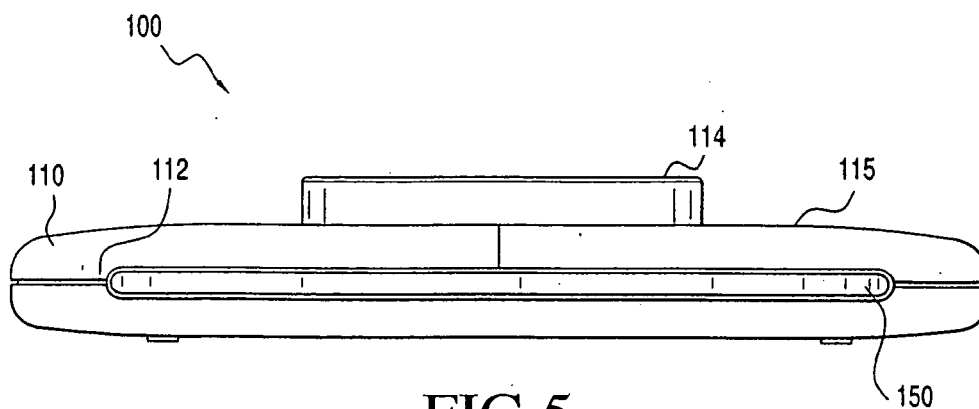

FIG. 5

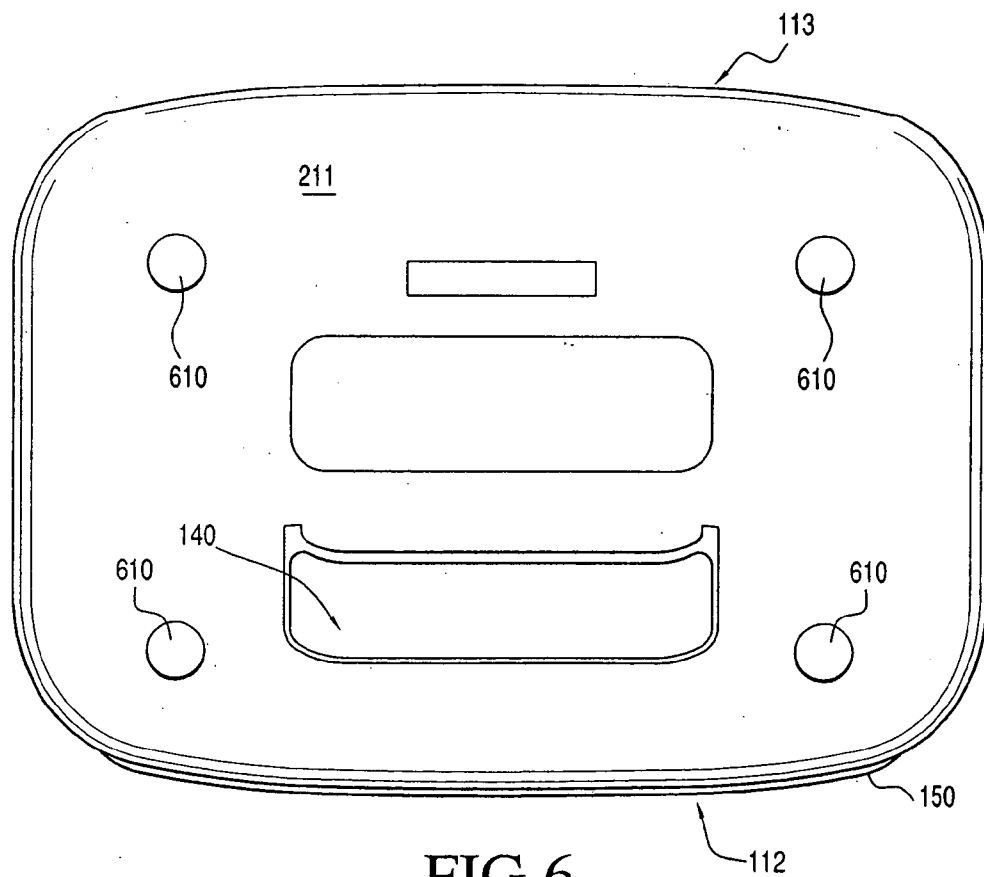
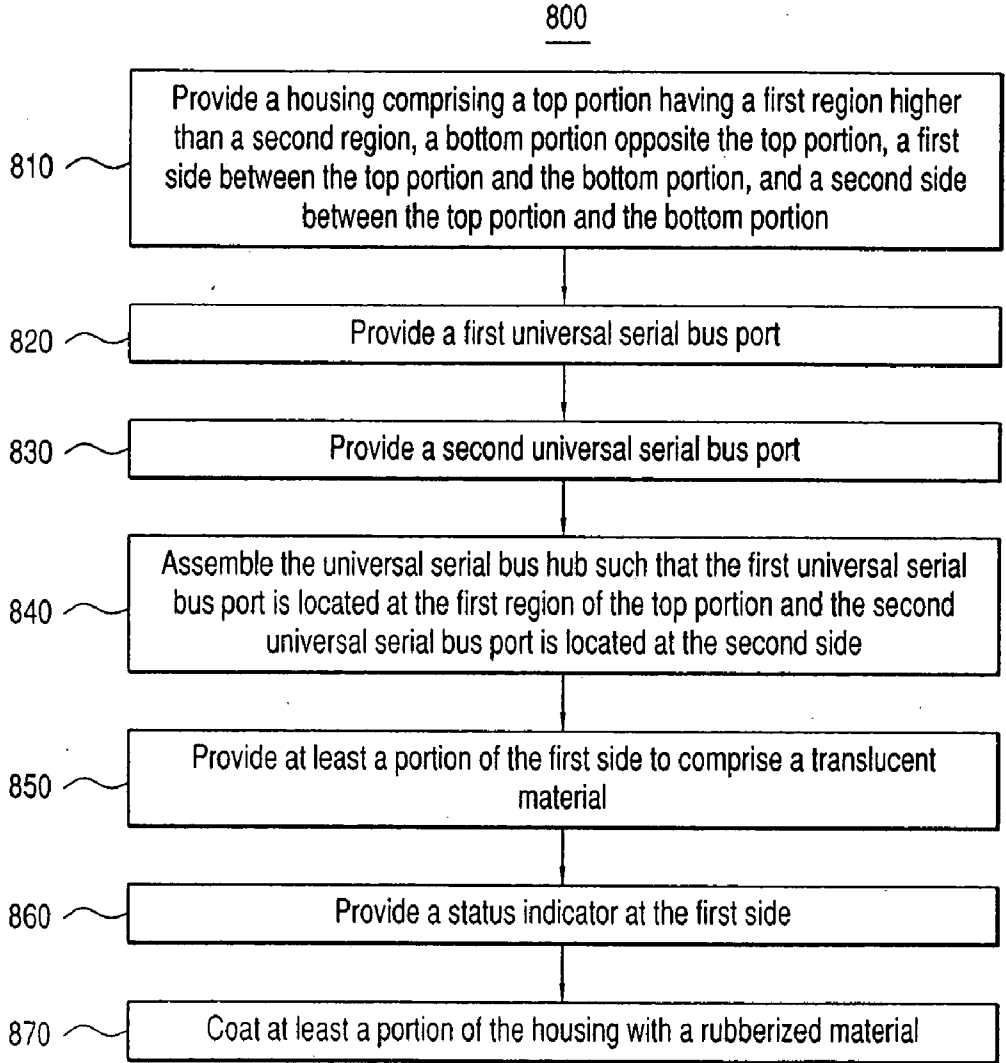

FIG. 6

FIG. 8



UNIVERSAL SERIAL BUS HUB AND METHOD OF MANUFACTURING SAME

CROSS-REFERENCE TO RELATED APPLICATION

[0001] This application is a continuation application of prior U.S. application Ser. No. 10/649,997 filed on Aug. 26, 2003, and entitled "Universal Serial Bus Hub and Method of Manufacturing Same", which is hereby incorporated by reference. Another continuation application with different claims is also being filed concurrently which claims priority to the same parent application. This other continuation is also incorporated by reference.

FIELD OF THE INVENTION

[0002] This invention relates generally to universal serial bus ports, and relates more particularly to hubs incorporating multiple universal serial bus ports.

BACKGROUND OF THE INVENTION

[0003] Universal serial bus technology has provided computer users with enhanced connectivity capabilities between computers and an increasingly wider range of peripheral devices. Universal serial bus hubs incorporating multiple universal serial bus ports into a single housing offer the ability to connect multiple peripheral devices to each other or to a computer via a universal serial bus connection. Although connecting a peripheral device using a universal serial bus hub can be as easy as simply plugging a peripheral device's universal serial bus cable into a universal serial bus port on the universal serial bus hub, existing universal serial bus hubs tend to place their ports in places that can be difficult to access. For example, existing universal serial bus hubs typically have ports located at a single side

BRIEF DESCRIPTION OF THE DRAWINGS

[0004] The invention will be better understood from a reading of the following detailed description, taken in conjunction with the accompanying figures in the drawings in which:

[0005] **FIG. 1** is an isometric view of a universal serial bus hub according to an embodiment of the invention;

[0006] **FIG. 2** is a side elevational view of the universal serial bus hub according to an embodiment of the invention;

[0007] **FIG. 3** is a top view of the universal serial bus hub according to an embodiment of the invention;

[0008] **FIG. 4** is a different side elevational view of the universal serial bus hub according to an embodiment of the invention;

[0009] **FIG. 5** is a still different side elevational view of the universal serial bus hub according to an embodiment of the invention;

[0010] **FIG. 6** is a bottom view of the universal serial bus hub according to an embodiment of the invention;

[0011] **FIG. 7** is an isometric view of two universal serial bus hubs in a stacked configuration according to an embodiment of the invention; and

[0012] **FIG. 8** is a flow chart illustrating a method of manufacturing a universal serial bus hub according to an embodiment of the invention.

[0013] For simplicity and clarity of illustration, the drawing figures illustrate the general manner of construction, and descriptions and details of well-known features and techniques may be omitted to avoid unnecessarily obscuring the invention. Additionally, elements in the drawing figures are not necessarily drawn to scale. For example, the dimensions of some of the elements in the figures may be exaggerated relative to other elements to help improve understanding of the present invention. The same reference numerals in different figures denote the same elements.

[0014] The terms "first," "second," "third," "fourth," and the like in the description and in the claims, if any, are used for distinguishing between similar elements and not necessarily for describing a particular sequential or chronological order. It is to be understood that the terms so used are interchangeable under appropriate circumstances such that the embodiments of the invention described herein are, for example, capable of operation in sequences other than those illustrated or otherwise described herein. Furthermore, the terms "comprise," "include," "have," and any variations thereof, are intended to cover a non-exclusive inclusion, such that a process, method, article, or apparatus that comprises a list of elements is not necessarily limited to those elements, but may include other elements not expressly listed or inherent to such process, method, article, or apparatus.

[0015] The terms "left," "right," "front," "back," "top," "bottom," "over," "under," and the like in the description and in the claims, if any, are used for descriptive purposes and not necessarily for describing permanent relative positions. It is to be understood that the terms so used are interchangeable under appropriate circumstances such that the embodiments of the invention described herein are, for example, capable of operation in other orientations than those illustrated or otherwise described herein. The term "coupled," as used herein, is defined as directly or indirectly connected in an electrical, mechanical, or other manner.

DETAILED DESCRIPTION OF THE DRAWINGS

[0016] In one embodiment of the invention, a universal serial bus hub comprises a housing having a top portion, a bottom portion opposite the top portion, a first side between the top portion and the bottom portion, and a second side between the top portion and the bottom portion. The universal serial bus hub further comprises a first universal serial bus port at the top portion and a second universal serial bus port at the second side. As it is used herein, the word "side" can mean a region or area along the perimeter of a rectangle, square, or other shape with straight sides, and can also mean a region or area along the perimeter of an oval, a circle, or other shape with curved or non-straight sides.

[0017] **FIG. 1** is an isometric view of a universal serial bus hub **100** according to an embodiment of the invention. **FIG. 2** is an elevational view of a side **113** of universal serial bus hub **100** according to an embodiment of the invention. Referring to **FIGS. 1 and 2**, universal serial bus hub **100** comprises a housing **110**, a universal serial bus port **120**, and a universal serial bus port **210**. In one embodiment, universal serial bus port **210** is oriented with its longer axis substantially parallel to top portion **111** and bottom portion

211 so as to reduce a height of universal serial bus hub **100**, as illustrated in **FIG. 2**. In another embodiment, universal serial bus port **210** can be oriented with its long axis substantially perpendicular to top portion **111** and bottom portion **211** so as to decrease a width of universal serial bus hub **100**.

[0018] Housing **110** comprises a top portion **111**, a bottom portion **211** opposite top portion **111**, a side **112** between top portion **111** and bottom portion **211**, and side **113** between top portion **111** and bottom portion **211**. Side **112** comprises a portion **150**, which can comprise a translucent material. In one embodiment, side **112** is located opposite side **113**. Universal serial bus port **120** is at top portion **111**, and universal serial bus port **210** is at side **113**. Universal serial bus hub **100** can further comprise a power port **220** at side **113**. In one embodiment, universal serial bus hub **100** further comprises a universal serial bus port **230** at side **113**. In one embodiment, universal serial bus port **210**, universal serial bus port **230**, and power port **220** are located in a recess **218**. At least a portion of housing **110** can be coated with a rubberized material.

[0019] In one embodiment, universal serial bus ports **120** and **210** comprise downstream universal serial bus ports, meaning universal serial bus ports **120** and **210** are configured to receive a universal serial bus connection from a peripheral device such as a printer, a scanner, a light, a fan, or the like. In the same or another embodiment, universal serial bus port **210** is one of a group of downstream universal serial bus ports. In one embodiment, the group of downstream universal serial bus ports consists of five downstream universal serial bus ports. In the same or another embodiment, universal serial bus port **120** is one of a group of downstream universal serial bus ports **120** located at region **114**. In a particular embodiment, the group of downstream universal serial bus ports consists of two downstream universal serial bus ports at region **114**. In the same or another embodiment, universal serial bus port **230** can comprise an upstream universal serial bus port, meaning universal serial bus port **230** is configured to receive one end of a universal serial bus cable the other end of which is attached to a computer. As an example, universal serial bus port **230** can be a mini B universal serial bus port.

[0020] Universal serial bus ports **120** are spaced apart by a distance **130**. As an example, distance **130** can be such that multiple non-corded universal serial bus devices can be simultaneously inserted into universal serial bus ports **120** without interference among the housings of such devices. In one embodiment, distance **130** is larger than a distance **235** between adjacent ones of universal serial bus ports **210**.

[0021] In one embodiment, top portion **111** comprises a region **114** and a region **115**, where region **114** is higher than region **115**. In that embodiment, universal serial bus port **120** is at region **114**. As an example, region **114** can be an extension that rises above region **115**, as illustrated in **FIG. 1**. As another example, region **114** can be integral with top portion **111** of housing **110**. As a different example, region **114** can be separate from top portion **111**, and can be integrated with housing **110** as a separate piece.

[0022] Locating universal serial bus port **120** at region **114** offers several advantages. For example, a user of universal serial bus hub **100** can insert a universal serial bus cable into universal serial bus port **120** with one hand without the need

to secure universal serial bus hub **100** in place with the other hand. Instead, universal serial bus hub **100** tends to stay in place because the downward force created by pushing the universal serial bus cable or device into universal serial bus port **120** is counterbalanced by an equal and opposite force pushing upward on universal serial bus hub **100** from the desk or other surface on which universal serial bus hub **100** is placed. As another example, universal serial bus port **120** is easily accessible by virtue of its raised position above region **115**.

[0023] In one embodiment, a hole **140** is located between side **112** and side **113** and extends from top portion **111** to bottom portion **211** of universal serial bus hub **100**. Hole **140** can also be adjacent to regions **114** and **115**.

[0024] **FIGS. 3-6** show universal serial bus hub **100** from additional perspectives beyond those shown in **FIGS. 1 and 2**. **FIG. 3** is a top view of universal serial bus hub **100** according to an embodiment of the invention. **FIG. 4** is a side elevational view of universal serial bus hub **100** according to an embodiment of the invention. **FIG. 5** is a different side elevational view of universal serial bus hub **100** according to an embodiment of the invention. **FIG. 6** is a bottom view of universal serial bus hub **100** according to an embodiment of the invention. **FIGS. 4 and 5** show different sides of universal serial bus hub **100** than does **FIG. 2**. The side of universal serial bus hub **100** substantially opposite the side illustrated in **FIG. 4** is, in one embodiment, substantially similar to the side illustrated in **FIG. 4**. As illustrated in **FIG. 6**, universal serial bus hub **100** further comprises feet **610** at bottom portion **211**. As an example, when universal serial bus hub **100** is placed on a work surface, feet **610** can support housing **110** above the work surface.

[0025] Universal serial bus hub **100** is stackable with a universal serial bus hub **700**, as illustrated in **FIG. 7**, which is an isometric view of two universal serial bus hubs in a stacked configuration according to an embodiment of the invention. Universal serial bus hub **700** is identical, or at least substantially similar to universal serial bus hub **100**, and each of the reference numerals used herein to identify elements of universal serial bus hub **100** should be understood to also refer to corresponding elements of universal serial bus hub **700**. **FIG. 7** illustrates a peripheral device **720** and a peripheral device **730** plugged into each of two universal serial bus ports **120** located at region **114** of universal serial bus hub **700**.

[0026] Referring to **FIG. 7**, it may be seen that region **114** of universal serial bus hub **100** extends into hole **140** of universal serial bus hub **700** when universal serial bus hub **700** is stacked on top of universal serial bus hub **100**. As further illustrated in **FIG. 7**, universal serial bus port **120** of universal serial bus hub **100** is accessible through hole **140** of universal serial bus hub **700** when universal serial bus hub **700** is stacked on top of universal serial bus hub **100**. Because of the manner in which region **114** of universal serial bus hub **100** extends into hole **140** of universal serial bus hub **700**, universal serial bus hubs **100** and **700** are self-aligned when universal serial bus hub **100** is stacked with universal serial bus hub **700**. Universal serial bus hubs **100** and **700** can also be stacked such that universal serial bus hub **100** is stacked on top of universal serial bus hub **700** and where region **114** of universal serial bus hub **700** extends

into hole 140 of universal serial bus hub 100. In one embodiment, region 114 of universal serial bus hub 100 or 700 extends partially into hole 140 of the other one of universal serial bus hub 100 or 700, but does not extend all the way through hole 140 of the other one of universal serial bus hub 100 or 700, as illustrated in FIG. 7.

[0027] Referring still to FIG. 7, universal serial bus hub 100 further comprises a status indicator 710 at side 112. Status indicator 710 indicates a status of at least one of power port 220, universal serial bus port 120, universal serial bus port 210, or universal serial bus port 230. As an example, status indicator 710 can light up to indicate that adequate power is being provided to universal serial bus hub 100, that one or more of power port 220, universal serial bus port 120, universal serial bus port 210, or universal serial bus port 230 are functioning properly, or the like. As a further example, status indicator 710 can be a light emitting diode. In one embodiment, status indicator 710 is visible through portion 150 of side 112, for example, through the translucent material of portion 150. In the same or another embodiment, status indicator 710 is one of a group of status indicators.

[0028] FIG. 8 is a flow chart illustrating a method 800 of manufacturing a universal serial bus hub according to an embodiment of the invention. A step 810 of method 800 is to provide a housing comprising a top portion having a first region higher than a second region, a bottom portion opposite the top portion, a first side between the top portion and the bottom portion, and a second side between the top portion and the bottom portion. As an example, the housing can be similar to housing 110, first shown in FIG. 1. As another example, the top portion can be similar to top portion 111, first shown in FIG. 1, and the bottom portion can be similar to bottom portion 211, first shown in FIG. 2. As a further example, the first region can be similar to region 114, first shown in FIG. 1, and the second region can be similar to region 115, first shown in FIG. 1. As yet another example, the first side can be similar to side 112, first shown in FIG. 1, and the second side can be similar to side 113, first shown in FIG. 2.

[0029] Step 810 or another step can further comprise providing a hole between the first side and the second side and extending from the top portion to the bottom portion. As an example, the hole can be similar to hole 140, first shown in FIG. 1.

[0030] A step 820 of method 800 is to provide a first universal serial bus port. As an example, the first universal serial bus port can be similar to universal serial bus port 120, first shown in FIG. 1.

[0031] A step 830 of method 800 is to provide a second universal serial bus port. As an example, the second universal serial bus port can be similar to universal serial bus port 210, first shown in FIG. 2.

[0032] A step 840 of method 800 is to assemble the universal serial bus hub such that the first universal serial bus port is located at the first region of the top portion and the second universal serial bus port is located at the second side.

[0033] A step 850 of method 800 is to provide at least a portion of the first side to comprise a translucent material. As an example, the portion of the first side can be similar to

portion 150, first shown in FIG. 1. In a different embodiment, step 850 can be performed simultaneously with, or as a part of, step 810.

[0034] A step 860 of method 800 is to provide a status indicator at the first side. As an example, the status indicator can be similar to status indicator 710, first shown in FIG. 7. Step 860 or another step can further comprise one or more of: providing the status indicator to be visible through the portion of the first side; and providing the status indicator to indicate a status of at least one of the first universal serial bus port and the second universal serial bus port. In a different embodiment, the status indicator can be assembled in the universal serial bus hub at step 840 such that the status indicator is visible through the portion of the first side.

[0035] A step 870 of method 800 is to coat at least a portion of the housing with a rubberized material. In a different embodiment, step 870 can be performed simultaneously with, or as a part of, step 810.

[0036] Although the invention has been described with reference to specific embodiments, it will be understood by those skilled in the art that various changes may be made without departing from the spirit or scope of the invention. Various examples of such changes have been given in the foregoing description. Accordingly, the disclosure of embodiments of the invention is intended to be illustrative of the scope of the invention and is not intended to be limiting. It is intended that the scope of the invention shall be limited only to the extent required by the appended claims. For example, to one of ordinary skill in the art, it will be readily apparent that the universal serial bus hub discussed herein may be implemented in a variety of embodiments, and that the foregoing discussion of certain of these embodiments does not necessarily represent a complete description of all possible embodiments.

[0037] All elements claimed in any particular claim are essential to the invention claimed in that particular claim. Consequently, replacement of one or more claimed elements constitutes reconstruction and not repair. Additionally, benefits, other advantages, and solutions to problems have been described with regard to specific embodiments. The benefits, advantages, solutions to problems, and any element or elements that may cause any benefit, advantage, or solution to occur or become more pronounced, however, are not to be construed as critical, required, or essential features or elements of any or all of the claims.

[0038] Moreover, embodiments and limitations disclosed herein are not dedicated to the public under the doctrine of dedication if the embodiments and/or limitations: (1) are not expressly claimed in the claims; and (2) are or are potentially equivalents of express elements and/or limitations in the claims under the doctrine of equivalents.

What is claimed is:

- 1. A universal serial bus hub comprising:
 - a housing comprising:
 - a top portion;
 - a bottom portion opposite the top portion;
 - a first side between the top portion and the bottom portion; and

a second side between the top portion and the bottom portion;

a first universal serial bus port at the top portion;

a second universal serial bus port at the second side; and

a power port at the second side.

2. The universal serial bus hub of claim 1 further comprising a third universal serial bus port at the second side and a fourth universal serial bus port at the second side.

3. The universal serial bus hub of claim 2 wherein the second universal serial bus port, the third universal serial bus port and the fourth universal serial bus port are all arranged in substantially a straight line when viewed in a side elevational view.

4. The universal serial bus hub of claim 3 wherein the line is substantially parallel to the bottom portion.

5. The universal serial bus hub of claim 2 further comprising a fifth universal serial bus port at the second side.

6. The universal serial bus hub of claim 3 further comprising a sixth universal serial bus port at the second side.

7. The universal serial bus hub of claim 6 further comprising a seventh universal serial bus port.

8. The universal serial bus hub of claim 7 wherein the seventh universal serial bus port is located at the top portion.

9. A universal serial bus hub comprising:

a housing comprising:

 a top portion;

 a bottom portion opposite the top portion;

 a curved or flat side; and

a universal serial bus port at the top portion;

a second universal serial bus port at the side;

a third universal serial bus port at the side;

a fourth universal serial bus port at the side;

a fifth universal serial bus port at the side; and

a sixth universal serial bus port at the side.

10. The universal serial bus hub of claim 9 wherein the second universal serial bus port, the third universal serial bus port, the fourth universal serial bus port, the fifth universal serial bus port, and the sixth universal serial bus port are all arranged in a substantially straight line when viewed in a side elevational view.

11. The universal serial bus hub of claim 9 wherein the second universal serial bus port, the third universal serial bus port, the fourth universal serial bus port, the fifth universal serial bus port, and the sixth universal serial bus port are all arranged in a substantially horizontal plane.

12. The universal serial bus hub of claim 9 further comprising a seventh universal serial bus port.

13. The universal serial bus hub of claim 12 wherein the seventh universal serial bus port is located at the top portion.

14. A method of manufacturing a universal serial bus hub, the method comprising:

providing a housing comprising:

 a top portion having a first region higher than a second region;

 a bottom portion opposite the top portion;

 a first side between the top portion and the bottom portion; and

 a second side between the top portion and the bottom portion;

providing a first universal serial bus port;

providing a second universal serial bus port; and

assembling the universal serial bus hub such that the first universal serial bus port is located at the first region of the and the second universal serial bus port is located at the second side.

15. The method of claim 14 wherein:

providing the housing further comprises:

 providing a hole between the first side and the second side and extending from the top portion to the bottom portion.

16. The method of claim 14 further comprising:

providing at least a portion of the first side to comprise a translucent material.

17. The method of claim 16 further comprising:

providing a status indicator at the first side;

providing the status indicator to be visible through the portion of the first side; and

providing the status indicator to indicate a status of at least one of the first universal serial bus port and the second universal serial bus port.

18. The method of claim 14 further comprising:

coating at least a portion of the housing with a rubberized material.

19. The method of claim 14 further comprising:

providing a third universal serial bus port;

providing a fourth universal serial bus port;

providing a fifth universal serial bus port;

providing a sixth universal serial bus port; and

assembling the universal serial bus hub such that the third universal serial bus port, the fourth universal serial bus port, the fifth universal serial bus port, and the sixth universal serial bus port are located at the second side.

20. The method of claim 19 further comprising:

assembling the universal serial bus hub such that the second universal serial bus port, the third universal serial bus port, the fourth universal serial bus port, the fifth universal serial bus port, and the sixth universal serial bus port are arranged in a substantially straight line when viewed in a side elevational view.