

C. E. TAYNTOR.
SASH FASTENER.

APPLICATION FILED JAN. 12, 1909.

917,379.

Patented Apr. 6, 1909.

Fig. 1.

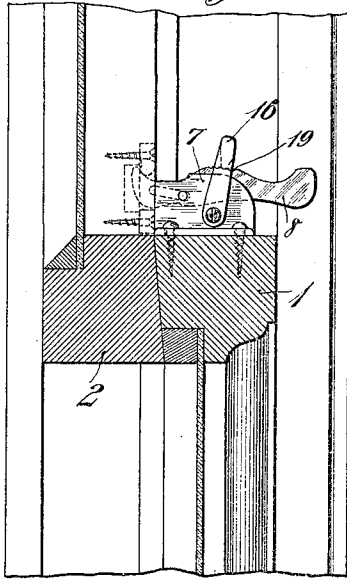

Fig. 2.

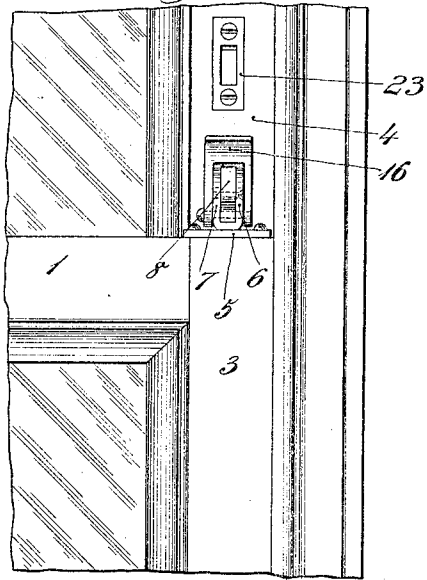

Fig. 3.

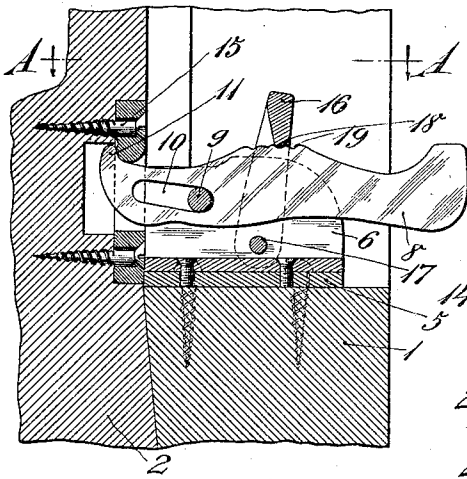

Fig. 4.

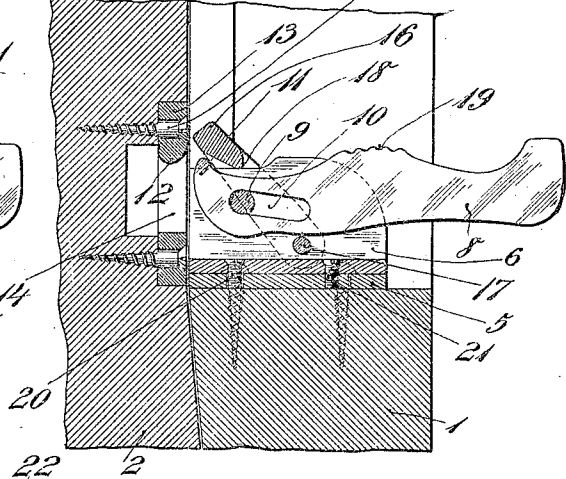
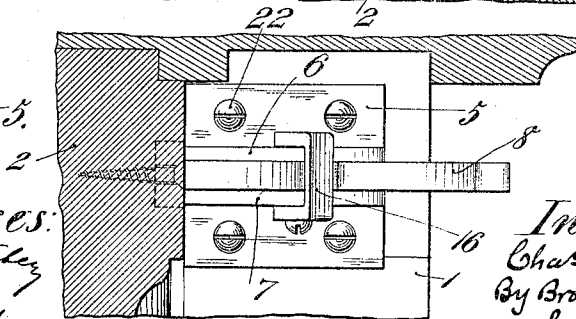

Fig. 5.



Witnesses:
A. G. [Signature]
F. George Bany.

Inventor:
Chas. E. Tayntor
By Brown & [Signature]
his Attorney

UNITED STATES PATENT OFFICE.

CHARLES E. TAYNTOR, OF NEW YORK, N. Y.

SASH-FASTENER.

No. 917,379.

Specification of Letters Patent.

Patented April 6, 1909.

Application filed January 12, 1909. Serial No. 471,941.

To all whom it may concern:

Be it known that I, CHARLES E. TAYNTOR, a citizen of the United States, and resident of the borough of Manhattan, in the city and State of New York, have invented a new and useful Improvement in Sash-Fasteners, of which the following is a specification.

My invention relates to sash fasteners with the object in view of providing a simple, effective and inexpensive fastener which will not require the use of spring tension.

A practical embodiment of my invention is represented in the accompanying drawings in which,

Figure 1 is a view of the fastener in side elevation as it appears in use, showing the horizontal parts of the lower and upper sash and glass in section; Fig. 2 is a front view of the same; Fig. 3 is an enlarged view in detail showing the fastener partly in elevation and partly in section and in fastening position with respect to the upper and lower sashes. Fig. 4 is a similar view showing the fastener in released position, and Fig. 5 is a horizontal section in the plane of the line A—A of Fig. 3, showing the fastener in top plan.

The top part of the lower sash is denoted by 1 and the lower part of the upper sash by 2. The side of the lower sash is denoted by 3 and the side of the upper sash by 4.

A base plate 5 has formed integral therewith or securely fastened thereto by rivets or other suitable means, a pair of uprising ears 6 and 7, between which the bolt 8 is pivoted by a pin 9, in such a manner that the bolt 8 may rock vertically on the pin 9 and also slide inwardly and outwardly on the pin 9, the bolt for this latter purpose being provided with an elongated slot 10 through which the pin 9 passes. The inner or engaging end of the bolt 8 is provided with a hook nose 11 for engaging a depending lip 12 on a keeper 13 which is let into and securely made fast to the side 4 of the upper sash. In the present instance I have shown the keeper 13 as consisting of an oblong plate of metal provided with an opening 14 for the reception of the inner end of the bolt 8 and the lip depends from the upper wall of the opening 14. The keeper is here shown as made fast in its position by means of screws 15. The base plate 5 is intended to be made fast to the top of the side 3 of the lower sash and the keeper 13 is so located at or near the base of the side 4 of the upper sash that the bolt 8 will be in position to enter the opening 14 in the keeper

when the lower sash is approximately down and the upper sash approximately up.

For holding the bolt 8 in its advanced position with its hook nose 11 engaging the lip 12, I provide a U-shaped clip 16 the branches of which embrace the ears 6 and 7 on the base plate, the clip being secured to the ears 6 and 7 in forwardly and backwardly swinging adjustment by means of a pivotal screw bolt or pin 17, in the present instance a threaded bolt having a screw head which passes through the branches of the U-shaped clip 16 and through the ears 6 and 7 and may be secured in position against liability of displacement by slightly offsetting its end. The top of the lip 16 is provided with a depending lip 18 which, when the clip is swung back into the position shown in Fig. 3; frictionally engages one or another of the several shallow notches 19 formed on the upper side of the bolt 8. In the form shown, the ears 6 and 7 are formed by bending a piece of metal U-shape and securing its crown to the base plate 5, by means of screws 20, 21. The base plate 5 itself is secured to the side 3 of the lower sash by means of screws 22.

In operation, assuming the bolt 8 to be in the position shown in Fig. 4 and the clip 16 in its released position, the sash may be locked by pushing the bolt 8 inwardly through the opening 14 in the keeper 13 and then pressing the outer end of the bolt 8 downwardly to hook the nose 11 against the lip 12, and in this position the bolt 8 may be locked by swinging the clip 16 back into the position shown in Fig. 3. The rounded end of the nose 11 of the bolt and the rounded edge of the lip 12 will serve to force the upper sash closely into engagement with the lower sash and also tend to force the upper sash upwardly and the lower downwardly, so that if either of these sashes is not in its proper position the operation of the device will force it snugly into position. This will prevent any rattling of the sashes and will make a tight closure between the sashes and between the sashes and frame.

In the event it is desired to lock the upper sash partially open, a second keeper 23 quite similar in all respects to the keeper 13 already described, may be inserted in the face of the side 4 of the upper sash at such a distance above the keeper 13 as may be desired.

The structure is one which requires no spring element in its construction and by the cam-like engagement of the bolt with the

keeper, locks the two sashes together tightly and in such a manner that they cannot be unlocked by any instrument passing between the sashes and only by manipulating the bolt 8 on that side of the sash where it projects.

It is obvious that changes might be resorted to in the form and arrangement of the parts without departing from the spirit and scope of my invention; hence I do not wish to limit myself strictly to the structure herein shown and described, but

What I claim is:

1. A sash fastener comprising a bolt, a keeper for engaging the bolt, means for mounting the bolt in longitudinally sliding and vertically rocking adjustment and means for holding the bolt in its locking position.

2. A sash fastener comprising a bolt, a support for the bolt, the said bolt and its support being provided the one with an elongated slot and the other with a pin passing through the slot for mounting the bolt in longitudinally sliding and vertically rocking adjustment, a keeper for receiving the end of the bolt and means for holding the bolt in locking position within the keeper.

3. A sash fastener comprising a bolt provided with a hook nose, a keeper for receiving the bolt and provided with a lip for engaging the said hook nose of the bolt, means for

mounting the bolt in longitudinally sliding and vertically rocking adjustment and means for holding the bolt in locked position.

4. A sash fastener comprising a bolt, a support for the bolt, the bolt and its support being provided the one with an elongated slot and the other with a pin passing through the slot to hold the bolt in longitudinally sliding and vertically rocking adjustment, a keeper for receiving the bolt and a swinging clip arranged to engage the bolt to hold it in locked adjustment.

5. A sash fastener comprising a base plate, ears uprising from the base plate, a bolt provided with an elongated slot and located between the ears, a pin passing through the ears and through the elongated slot to hold the bolt in longitudinal and vertically rocking adjustment, a keeper for receiving the bolt and a U-shaped clip hinged to the support and embracing the bolt for holding the bolt in locking adjustment.

In testimony, that I claim the foregoing as my invention, I have signed my name in presence of two witnesses, this eleventh day of January 1909.

CHARLES E. TAYNTOR.

Witnesses:

F. GEORGE BARRY,
C. S. SUNDGREN.